

PWM DC/DC Converter IC with Standby Function

■GENERAL DESCRIPTION

The NJM2345 is a step down PWM DC/DC converter IC. An internal 1.5A power transistor, a pulse-by pulse current limit circuit and a 1% precision reference make the NJM2345 suitable for a wide range of voltage converter needs. The NJM2345 features a standby function that can be used for both power saving and safety operation.

■PACKAGE OUTLINE

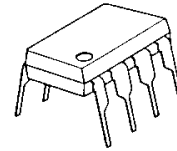

NJM2345D

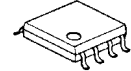

NJM2345M

■FEATURES

- Operating Voltage 3.0V to 40V
- Wide Oscillator Frequency 1kHz to 150kHz
- Maximum duty ratio 100%
- Precision Reference Voltage $V_{th}=1.25V \pm 1\%$
- Internal High Power Transistor 1.5A max.
- Internal Over Current Limit Circuit
- PWM switching control
- Standby Function 9 μ A typ.
- Bipolar Technology
- Package Outline NJM2345D : DIP8
 NJM2345M : DMP8

■PIN CONFIGURATION

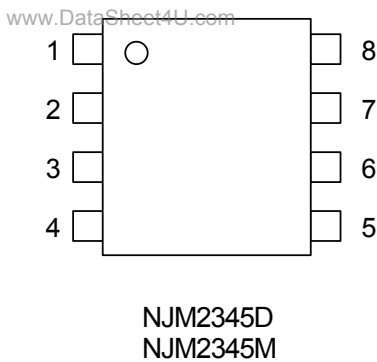

- PIN FUNCTION**
1. C_S
 2. E_S
 3. C_T
 4. GND
 5. IN-
 6. V^+
 7. ON/OFF
 8. S_I

■BLOCK DIAGRAM

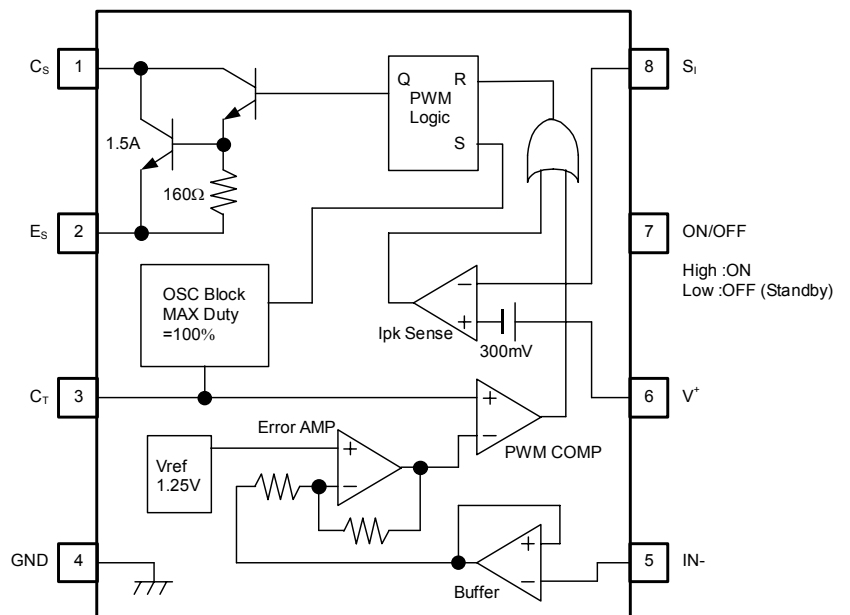

■ABSOLUTE MAXIMUM RATINGS (Ta=25°C)

PARAMETER	SYMBOL	MAXIMUM RATINGS	UNIT	
Maximum Supply Voltage	V ⁺	40	V	
Comparator Input Voltage	V _{IR}	-0.3 ~ 40 (note)	V	
ON/OFF Terminal Voltage	V _{ON/OFF}	-0.3 ~ 40 (note)		
Output Switch Voltage	V _{SW}	40	V	
Output Switch Current	I _{SW}	1.5	A	
Power Dissipation	P _D	DIP8	875	mW
		DMP8	580 (*1)	
			750 (*2)	
Operating Temperature Range	Topr	-40 ~ +85	°C	
Storage Temperature Range	Tstg	-50 ~ +150	°C	

(note) When supply voltage is less than 40V, the absolute maximum input voltage is equal to the supply voltage.

(*1) At on PC board : 114.3mm × 76.2mm × 1.6mm(2 layer FR-4) : Conform to EIA/JEDEC

(*2) At on PC board : 114.3mm × 76.2mm × 1.6mm(4 layer FR-4) : Conform to EIA/JEDEC

■POWER DISSIPATION vs. AMBIENT TEMPERATURE

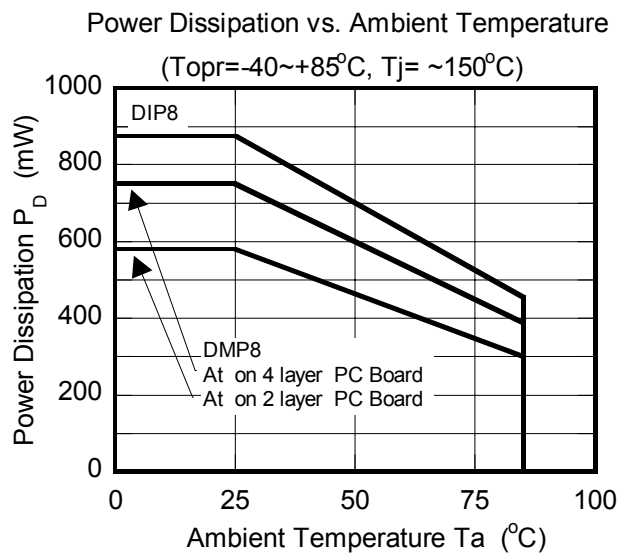

www.DataSheet4U.com

■ ELECTRICAL CHARACTERISTICS

DC Characteristics ($V^+ = V_{ON/OFF} = 5V$, $T_a = 25^\circ C$)

PARAMETER	SYMBOL	TEST CONDITIONS	MIN.	TYP.	MAX.	UNIT
-----------	--------	-----------------	------	------	------	------

OSCILLATOR BLOCK

Oscillation Frequency	f_{OSC}	$I_N = V_{th} - 5V$, $C_T = 1nF$	18	27	36	kHz
Charge Current	I_{chg}		11	18	27	μA
Discharge Current	I_{dis}		110	180	300	μA
Voltage Swing	V_{OSC}	$C_T = 1nF$	—	0.5	—	V_{P-P}

CURRENT LIMIT

Peak Current Sense Voltage	V_{ipk}		250	300	350	mV
----------------------------	-----------	--	-----	-----	-----	----

OUTPUT SWITCH

Saturation Voltage	V_{sat}	$I_{SW} = 0.7A$	—	1.0	1.3	V
Output Transistor Bias Resistance	R_{bias}		—	160	—	Ω
Collector Off-State Current	$I_{C(Off)}$	$V_{CE} = 40V$	—	0.01	1	μA
Maximum duty ratio	M_{AXDUTY}	$I_N = 0V$	100	—	—	%

ERROR AMPLIFIER

Threshold Voltage	V_{th}		1.2375	1.250	1.2625	V
Input Bias Current	I_{IB}	$I_N = V_{th}$	—	100	200	nA

ON/OFF BLOCK

ON Threshold Voltage	V_{ON}		0.8	—	—	V
OFF Threshold Voltage	V_{OFF}		—	—	0.56	V
Input Bias Current (ON/OFF Terminal)	$I_{ON/OFF}$	$V_{ON/OFF} = 5V$	—	240	300	μA

GENERAL CHARACTERISTICS

Standby Current	I_{CCSTBY}	$V_{ON/OFF} = 0V$	—	9	20	μA
Operating Current	I_{CC}	$C_T = 1nF$, $S_I = V^+$, $I_N > V_{th}$, $E_S = GND$	—	2.8	4.0	mA

(note) Output switch tests are performed under pulsed conditions to minimize power dissipation.

■ TYPICAL APPLICATIONS

Step-Down Converter

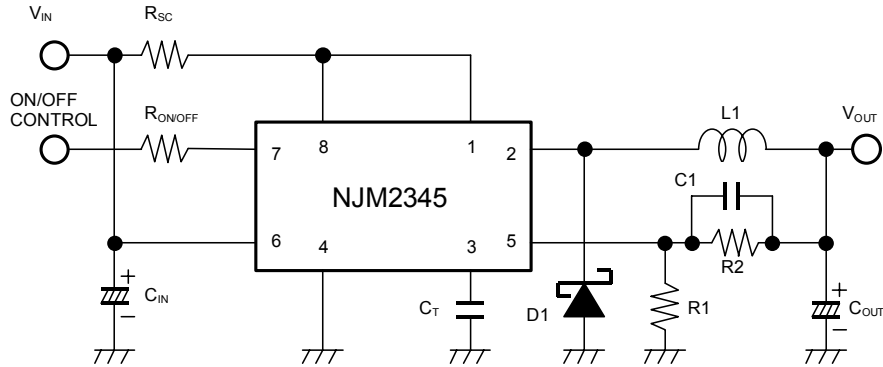

Though the $I_{ON/OFF}$ decreases by inserting " $R_{ON/OFF}$ " to between ON/OFF terminal and V_{IN} terminal, the minimum operating voltage is increased due to the resistor " $R_{ON/OFF}$ ".

D1 use to schottky diode.

Step-Down Converter (High Current)

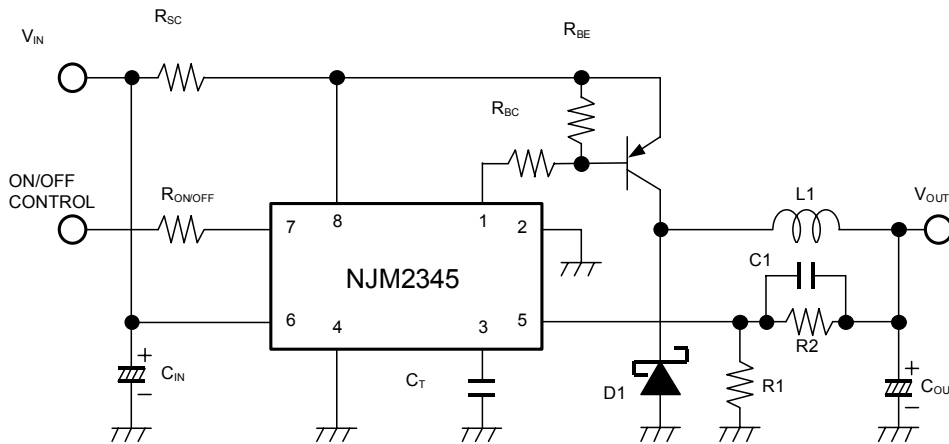

www.DataSheet4U.com

Though the $I_{ON/OFF}$ decreases by inserting " $R_{ON/OFF}$ " to between ON/OFF terminal and V_{IN} terminal, the minimum operating voltage is increased due to the resistor " $R_{ON/OFF}$ ".

D1 use to schottky diode.

■TIMING CHART

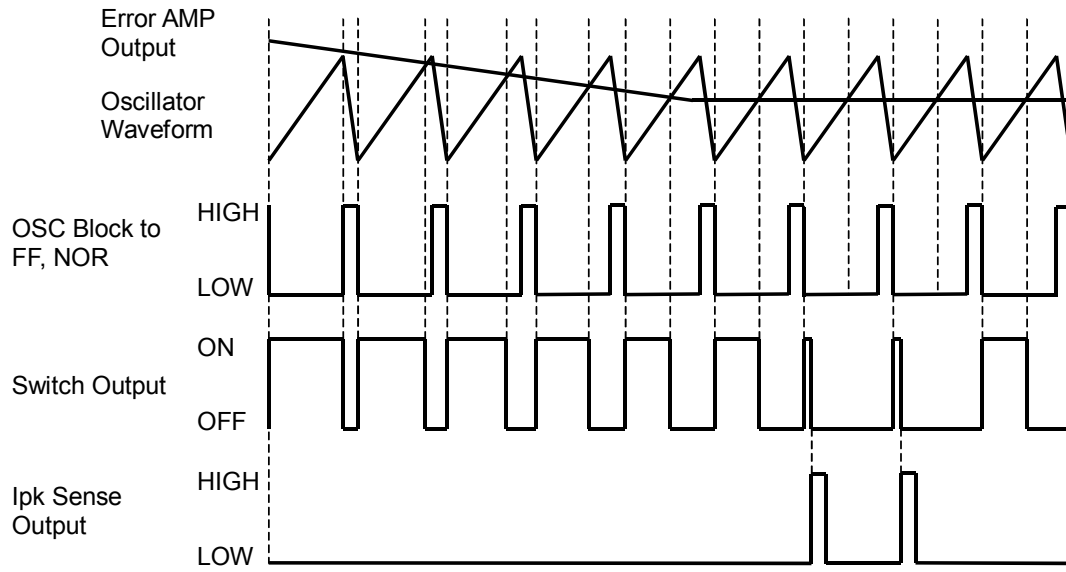

■ TYPICAL CHARACTERISTICS

Oscillator Frequency vs. Timing Capacitor

($V^+ = 5V$, $S_1 = V^+$, Pin 5 = GND, $T_a = 25^\circ C$)

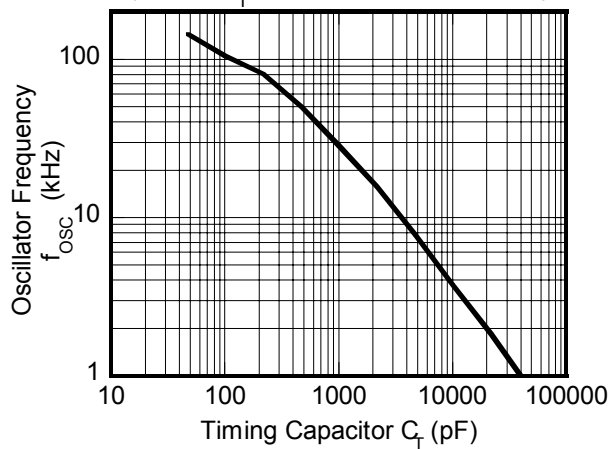

Saturation Voltage vs. Collector Current

($V^+ = 5V$, $C_S = C_D$, $T_a = 25^\circ C$)

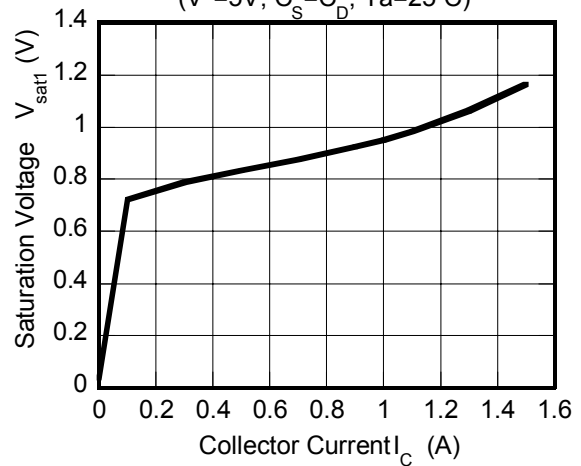

Input Bias Current vs. IN- Terminal Voltage

($V^+ = 5V$, $T_a = 25^\circ C$)

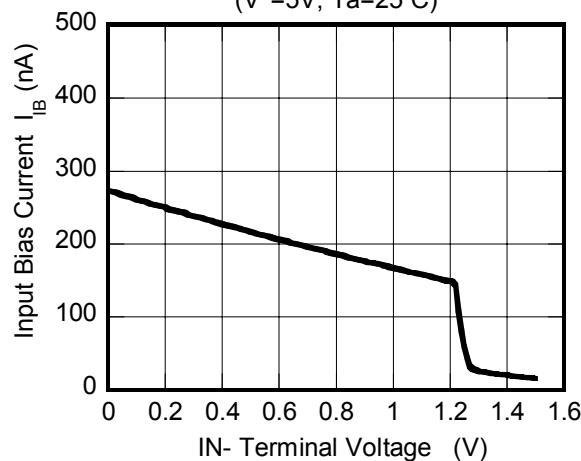

www.DataSheet4U.com

Operating Current vs. Operating Voltage

($C_T = 1nF$, $S_1 = V^+$, $IN \rightarrow V_{th}$, $Es = GND$, $T_a = 25^\circ C$)

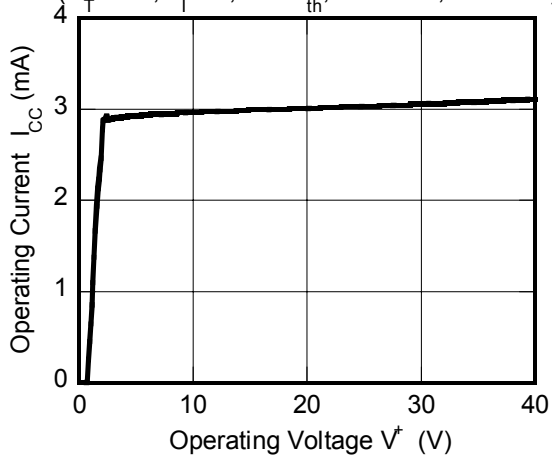

Output Voltage vs. ON Threshold Voltage

($V^+ = 10V$, $V_o = 5V$, $I_o = 150mA$, $T_a = 25^\circ C$)

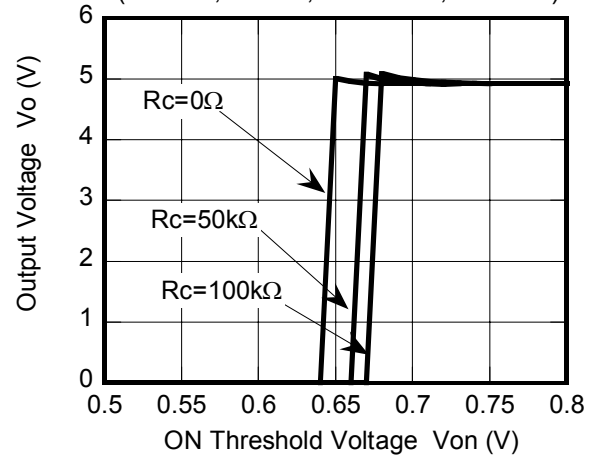

■ TYPICAL CHARACTERISTICS

ON/OFF Input Bias Current vs. ON/OFF Terminal Voltage

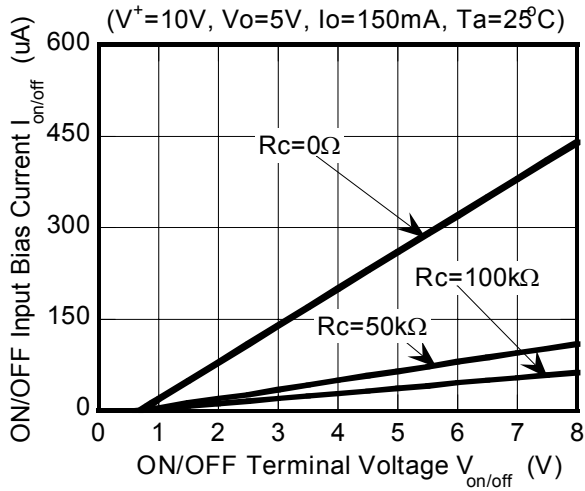

Threshold Voltage vs. Temperature

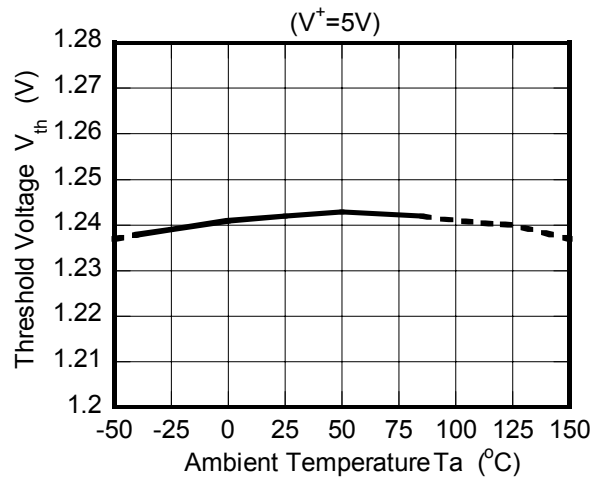

Saturation Voltage vs. Temperature

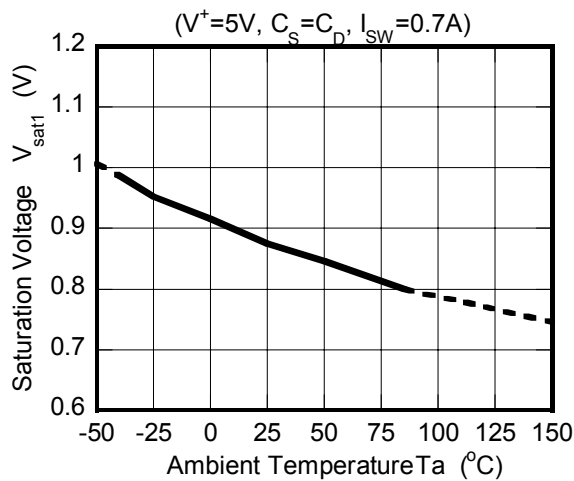

www.DataSheet4U.com

Current Limit Sense Voltage vs. Temperature

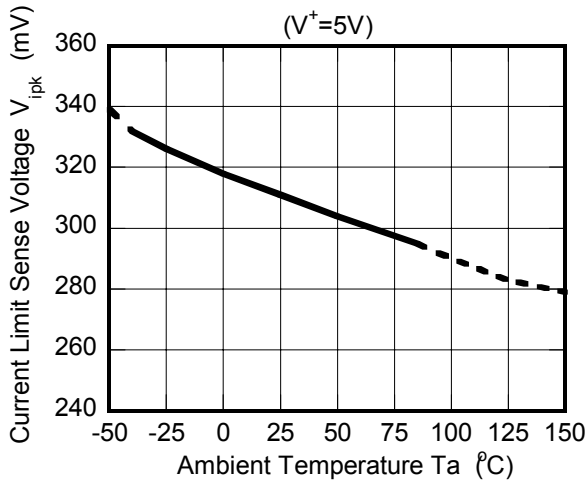

Operating Current vs. Temperature

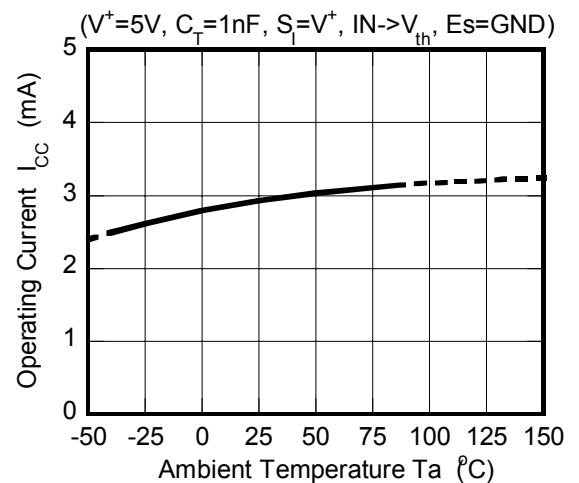

MEMO

www.DataSheet4U.com

[CAUTION]
The specifications on this databook are only given for information, without any guarantee as regards either mistakes or omissions. The application circuits in this databook are described only to show representative usages of the product and not intended for the guarantee or permission of any right including the industrial rights.