

POWER FACTOR CONTROLLER

■ GENERAL DESCRIPTION

The **NJM2375/A** are active power factor controllers, which limit the harmonic current resulting from the power supply block of electrical devices.

They include a startup timer, an one quadrant multiplier, a zero current detector to ensure critical condition operation, a transconductance error amplifier, high precision reference, a current sensing comparator, and a totem pole output ideally suited for driving a power MOSFET.

They also contain protection circuits for overvoltage, cycle-by-cycle overcurrent, and maximum peak current.

The startup threshold of **NJM2375A** is lower than that of **NJM2375**.

■ PACKAGE OUTLINE

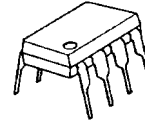

NJM2375D/AD



NJM2375M/AM



NJM2375V/AV

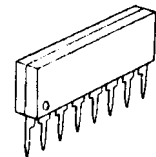

NJM2375L/AL

■ FEATURES

- Overvoltage Comparator Eliminates Runaway Output Voltage
- Internal Quick Start
- Internal Startup Timer
- One Quadrant Multiplier
- Zero Current Detector
- High Precision Reference ($\pm 2\%$)
- Totem Pole Output with High State Clamp
- Undervoltage Lockout
(Startup Threshold/**NJM2375**:13V typ., **NJM2375A**:10.4V typ.)
- Low Startup and Operating Current
- Bipolar Technology
- Package Outline DIP8,DMP8,SSOP14,SIP8

■ PIN CONFIGURATION

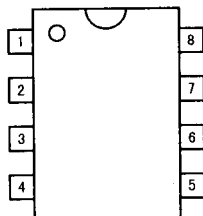

NJM2375D/AD
NJM2375M/AM

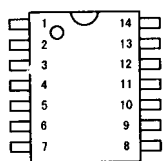

NJM2375V/AV

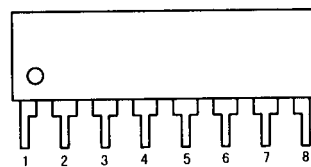

NJM2375L/AL

PIN FUNCTION

- | | |
|-----------------------|----------------------|
| 1. M _{ULT} | 8. DRIVE |
| 2. NC | 9. NC |
| 3. C _{SENSE} | 10. V ⁺ |
| 4. NC | 11. NC |
| 5. D _{ZERO} | 12. V _{FB} |
| 6. NC | 13. NC |
| 7. GND | 14. C _{OMP} |

PIN FUNCTION

1. V_{FB}
2. C_{OMP}
3. M_{ULT}
4. C_{SENSE}
5. D_{ZERO}
6. GND
7. DRIVE
8. V⁺

NJM2375/A

■ BLOCK DIAGRAM

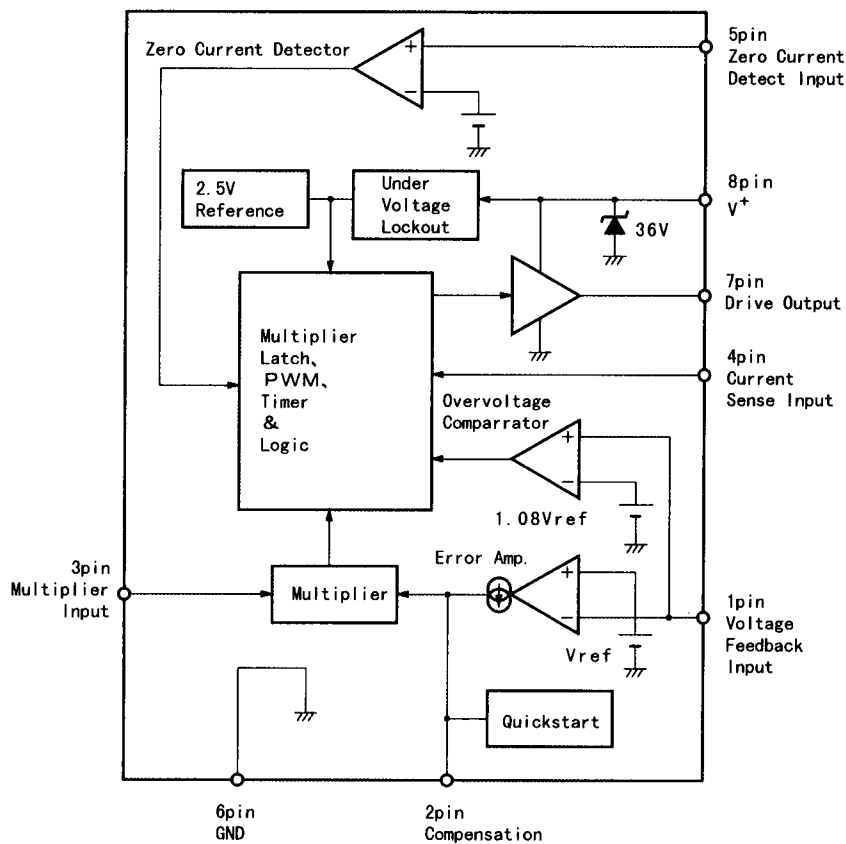

■ ABSOLUTE MAXIMUM RATINGS (T_a=25°C)

PARAMETER	SYMBOL	RATINGS	UNIT
Total Power Supply and Zener Current	I _{CC+Iz}	30	mA
Output Current (Source or Sink)	I _O	500	mA
Current Sense, Multiplier, and Voltage Feedback Inputs	V _{IN}	-1.0 to +10	V
Zero Current Detect Input			
High State Forward Current	I _{IN}	50	mA
Low state Forward Current		-10	
Power Dissipation	P _D	(DIP8) 500 (DMP8) 300 (SSOP14) 300 (SIP8) 700	mW
Operating Temperature Range	T _{OPR}	-40 to +85	°C
Storage Temperature Range	T _{STG}	-50 to +150	°C

■ ELECTRICAL CHARACTERISTICS ($V^+=12V^{*1}$, $T_a=25^{\circ}C$)

● ERROR AMPLIFIER

PARAMETER	SYMBOL	TEST CONDITION	MIN.	TYP.	MAX.	UNIT
Voltage Feedback input Threshold 1	V_{FB1}	$V^+=12V$	2.465	2.500	2.535	V
Voltage Feedback input Threshold 2	V_{FB2}	$V^+=28V$	2.440	2.500	2.540	V
Line Regulation	RegLine	$V^+=12$ to $28V$	-	1.0	10	mV
Input Bias Current	I_{IB}	$V_{FB}=0V$	-	-0.1	-0.5	μA
Transconductance	gm		80	100	130	μmho
Output Current (Source)	I_{OSO}	$V_{FB}=2.3V$	-	10	-	μA
Output Current (Sink)	I_{OSI}	$V_{FB}=2.7V$	-	10	-	μA
Output Voltage Swing 1	$V_{OH(ea)}$	$V_{FB}=2.3V$ (High State)	5.8	6.4	-	V
Output Voltage Swing 2	$V_{OL(ea)}$	$V_{FB}=2.7V$ (Low State)	-	1.7	2.4	V

● OVERVOLTAGE COMPARATOR

PARAMETER	SYMBOL	TEST CONDITION	MIN.	TYP.	MAX.	UNIT
Voltage Feedback Input Threshold	$V_{FB(OV)}$		1.065 $\times V_{FB}$	1.080 $\times V_{FB}$	1.095 $\times V_{FB}$	V

● MULTIPLIER

PARAMETER	SYMBOL	TEST CONDITION	MIN.	TYP.	MAX.	UNIT
Input Bias Current	I_{IB}	$V_{FB}=0V$ (FB Pin)	-	-0.1	-0.5	μA
Input Threshold	$V_{th(M)}$	(FB Pin)	1.05 V_{OL} \times (EA)	1.20 V_{OL} \times (EA)	-	V
Dynamic Input Voltage Range	V_{PIN3}	Multiplier Input Pin	0 to 2.5	0 to 3.5	-	V
	V_{PIN2}	Compensation Pin	$V_{th(M)}$ to $V_{th(M)}$ +1.0V	$V_{th(M)}$ to $V_{th(M)}$ +1.5V	-	V
Multiplier Gain ^{*2}	K	$V_{mp}=0.5V$, $V_{comp}=V_{th(M)}+1.0V$	0.43	0.65	0.87	μmho

● ZERO CURRENT DETECTOR

PARAMETER	SYMBOL	TEST CONDITION	MIN.	TYP.	MAX.	UNIT
Input Threshold Voltage	V_{th}	V^+ Increasing	1.33	1.60	1.87	V
Hysteresis	V_H	V^+ Decreasing	100	200	300	mV
Input Clamp Voltage	V_{IH}	High State ($I_{DET}=+3.0mA$)	5.20	5.80	-	V
	V_{IL}	Low State ($I_{DET}=-3.0mA$)	0.30	0.70	1.00	V

NJM2375/A

■ ELECTRICAL CHARACTERISTICS ($V^+=12V^{*1}$, $T_a=25^\circ C$)

● CURRENT SENSING COMPARATOR

PARAMETER	SYMBOL	TEST CONDITION	MIN.	TYP.	MAX.	UNIT
Input Bias Current	I_{IB}	$I_{sense}=0V$	-	-0.15	-1.0	μA
Input Offset Voltage	V_{IO}	$V_{compe}=1.10V$, $V_M=0V$	-	9.0	25.0	mV
Maximum Current Sense Input Threshold *3	$V_{th(MAX)}$		1.30	1.50	1.80	V
Delay to Output	tPHL		-	200	-	nS

● DRIVE OUTPUT

PARAMETER	SYMBOL	TEST CONDITION	MIN.	TYP.	MAX.	UNIT
Output Voltage Low State	V_{OL1}	$I_{sink}=20mA$	-	0.3	0.8	V
	V_{OL2}	$I_{sink}=200mA$	-	2.4	3.3	V
Output Voltage High State	V_{OH1}	$I_{source}=20mA$	9.8	10.3	-	V
	V_{OH2}	$I_{source}=200mA$	7.8	8.4	-	V
Output Voltage High State	$V_{C(MAX)}$	$I_{source}=20mA$, $CL=15pF$, $V^+=30V$	14	16	18	V
Output Voltage Rise Time	tr	$CL=1.0nF$	-	100	150	nS
Output Voltage Fall Time	tf	$CL=1.0nF$	-	50	120	nS
Output Voltage with UVLO Activated	$V_{C(UVLO)}$	$V^+=7V$, $I_{sink}=1.0mA$	-	0.1	0.5	V

● RESTART TIMER

PARAMETER	SYMBOL	TEST CONDITION	MIN.	TYP.	MAX.	UNIT
Restart Time Delay	tDLY		200	620	-	μS

■ ELECTRICAL CHARACTERISTICS ($V^+=12V^{*1}$, $T_a=25^\circ C$)

● UNDERVOLTAGE LOCKOUT

PARAMETER	SYMBOL	TEST CONDITION	MIN.	TYP.	MAX.	UNIT
(NJM2375)						
Startup Threshold	$V_{th(on)}$	V^+ Increasing	11.5	13.0	14.5	V
Minimum Operating	$V_{shutdown}$	V^+ Decreasing	7.0	8.0	9.0	V
Voltage After Turn-On Hysteresis	V_H		3.8	5.0	6.2	V
(NJM2375A)						
Startup Threshold	$V_{th(on)}$	V^+ Increasing	9.4	10.4	11.4	V
Minimum Operating	$V_{shutdown}$	V^+ Decreasing	6.8	7.8	8.8	V
Voltage After Turn-On Hysteresis	V_H		1.4	2.6	3.8	V

● TOTAL DEVICE

PARAMETER	SYMBOL	TEST CONDITION	MIN.	TYP.	MAX.	UNIT
Power Supply Current						
Startup	I_{CC1}	$V^+=7.0V$	-	0.25	0.4	mA
Operating	I_{CC2}		-	6.5	12	mA
Dynamic Operating	I_{CC3}	50kHz, $CL=1.0nF$	-	9.0	20	mA
Power Supply Zener Voltage ^{*4}	V_Z	$I_{CC}=25mA$	30	36	-	V

● NOTES

*1 : Adjust V^+ above the startup threshold before setting to 12V.

$$*2 : K = \frac{V_{th(max)}}{V_M \times (V_{comp} - V_{th(M)})}$$

*3 : This parameter is measured with $V_{FB}=0V$, and $V_M=3.0V$.

*4 : Do not supply higher voltage above the zener voltage to 8pin, because the internal zener diode protects the IC from surge.

NJM2375/A

■ TYPICAL APPLICATIONS

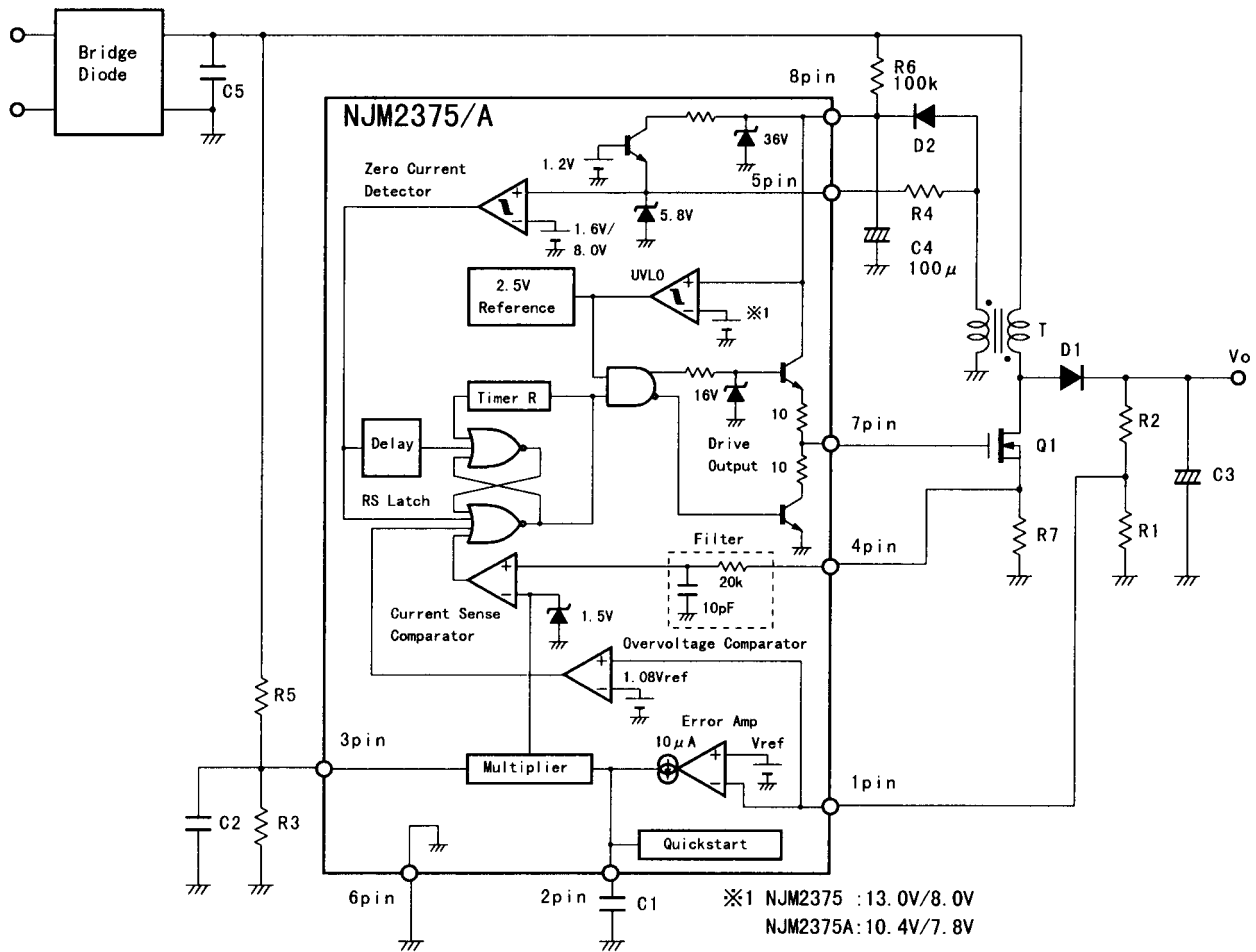

■ TYPICAL CHARACTERISTICS

Current Sense Input Threshold vs. Multiplier Input
($V^+ = 12V, T_a = 25^\circ C$)

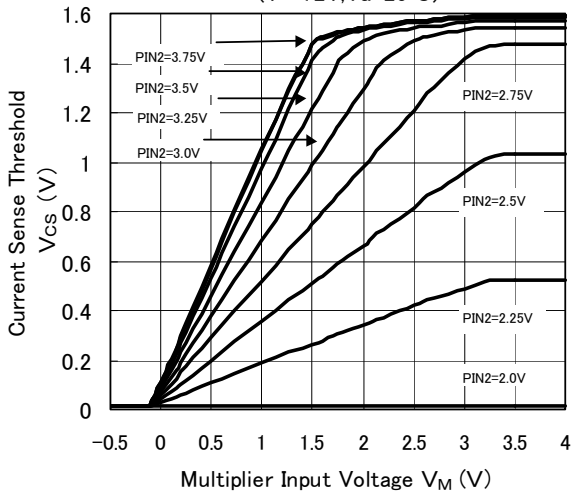

Current Sense Input Threshold vs. Multiplier Input (Expanded View)
($V^+ = 12V, T_a = 25^\circ C$)

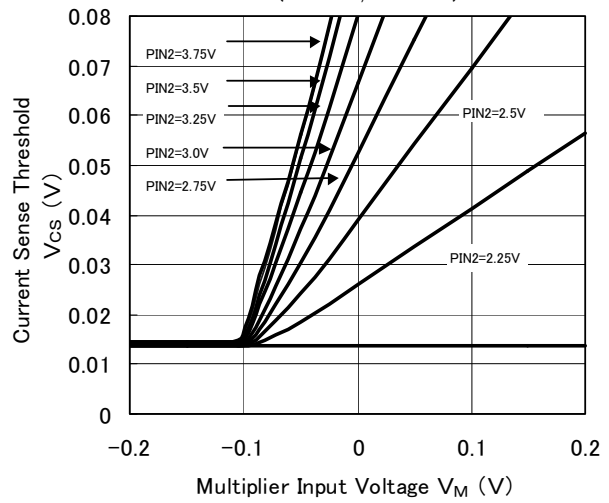

Supply Current vs. Supply Voltage (NJM2375)
($V_{FB} = 0V, C_L = 1nF, f = 50kHz, T_a = 25^\circ C$)

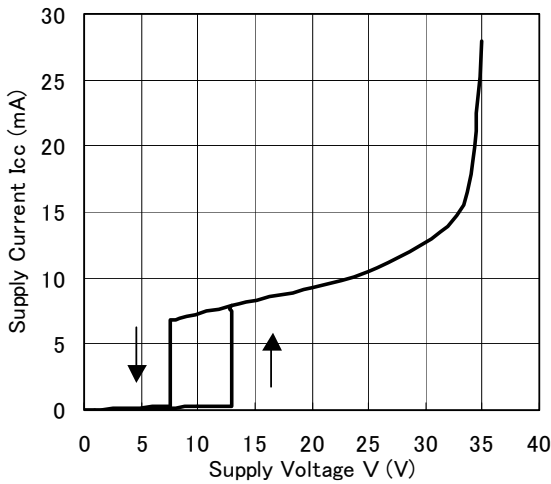

Supply Current vs. Supply Voltage (NJM2375A)
($V_{FB} = 0V, C_L = 1nF, f = 50kHz, T_a = 25^\circ C$)

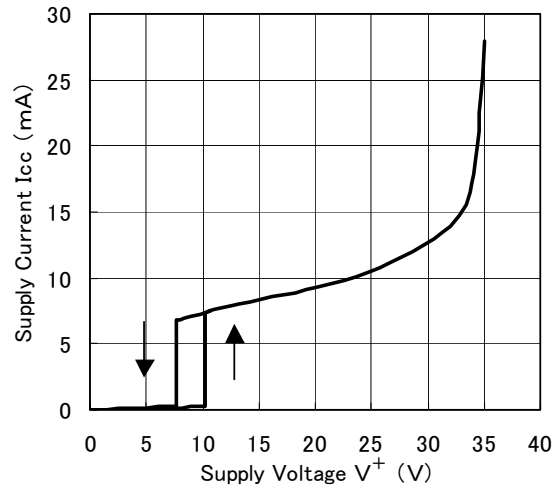

Drive Output Voltage vs. Output Current
($V^+ = 12V, T_a = 25^\circ C$)

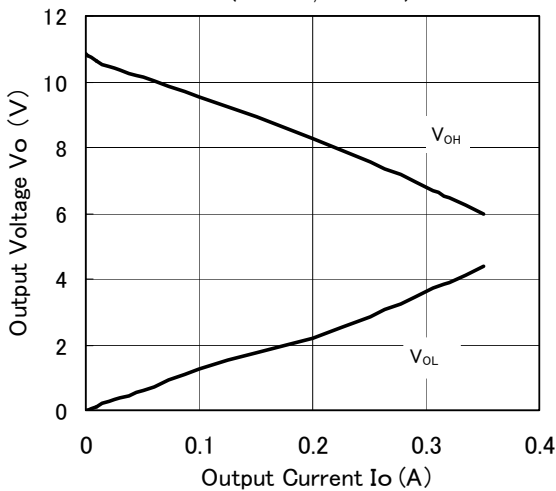

Drive Output Waveform
($V^+ = 12V, C_L = 1nF, f = 150kHz, T_a = 25^\circ C$)

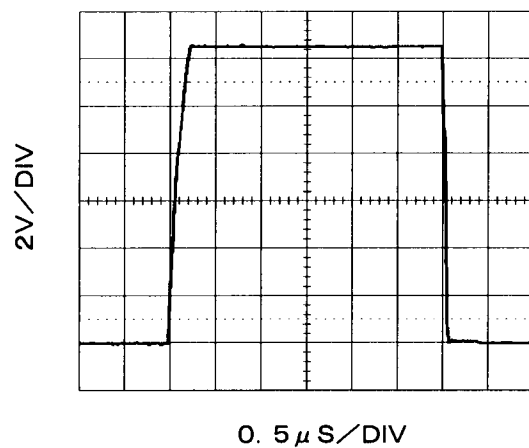

■ TYPICAL CHARACTERISTICS

Voltage Feedback Input Threshold Change vs. Temperature ($V^+=12V$)

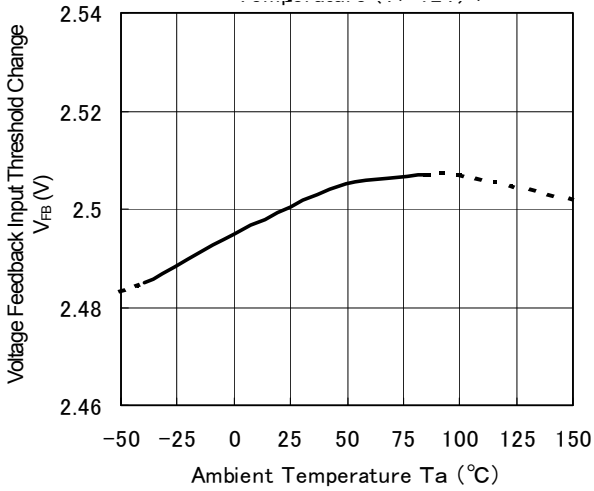

Overvoltage vs. Temperature ($V^+=12V$)

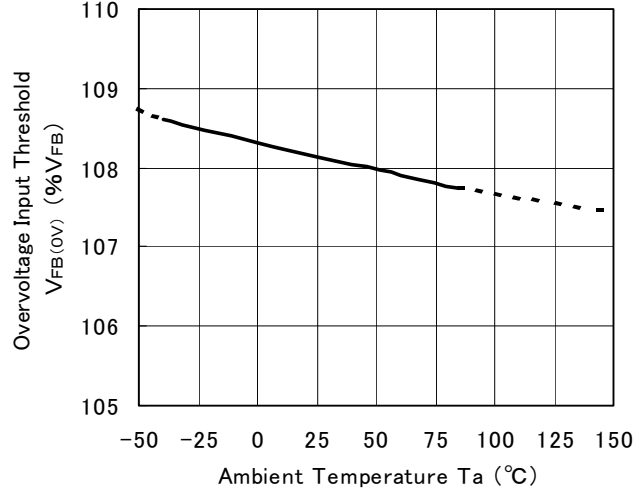

Quickstart Charge Voltage - Current vs. Temperature ($V^+=12V$)

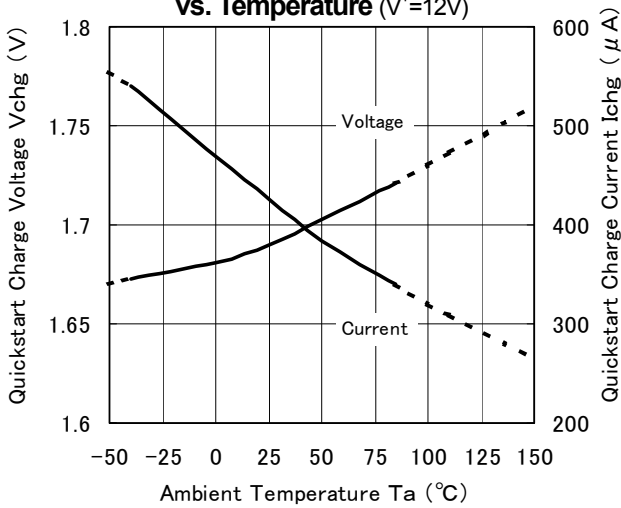

Restart Timer Delay vs. Temperature ($V^+=12V$)

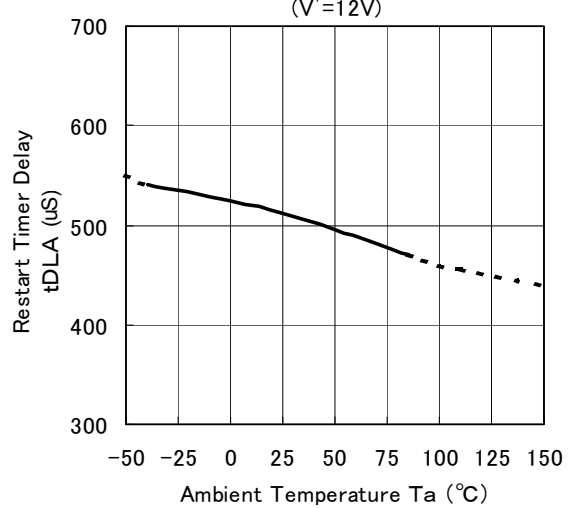

Undervoltage Lockout Thresholds vs. Temperature

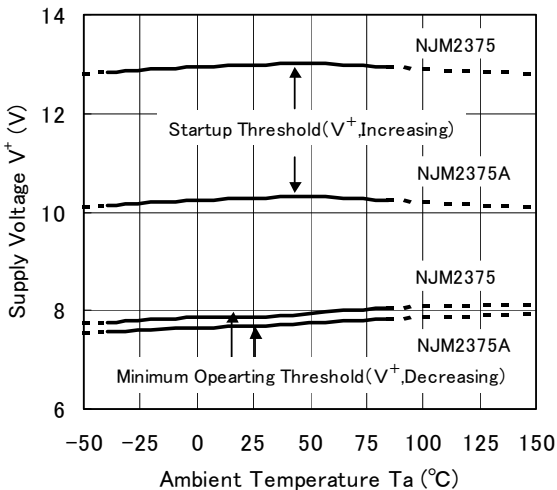

Zero Current Detector Input Threshold Voltage vs. Temperature ($V^+=12V$)

