

6CH VIDEO AMPLIFIER WITH SD/ HD LPF

■ GENERAL DESCRIPTION

The NJM2565 is a single supply voltage 6ch Video amplifier. It includes LPF, Y/C MIX circuit and SDC interface. LPF for the component signal can select SD/HD. The NJM2565 is suitable for DVD recorder, set top box and the high quality AV systems with the SD/HD output.

■ PACKAGE OUTLINE

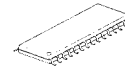

NJM2565V

■ FEATURES

- Operating Voltage +4.5 to +5.5V
- 6dB amplifier
- Internal 75Ω Driver Circuit (2-system drive)
- Internal LPF

V, SY, SC	6.75MHz
Y, Pb, Pr	13.5MHz (Progressive)
	30MHz (HD)
- Y/C MIX Circuit
- SDC Interface (S1/ S2)
- Power Save Circuit
- Bipolar Technology
- Package Outline SSOP32

■ BLOCK DIAGRAM

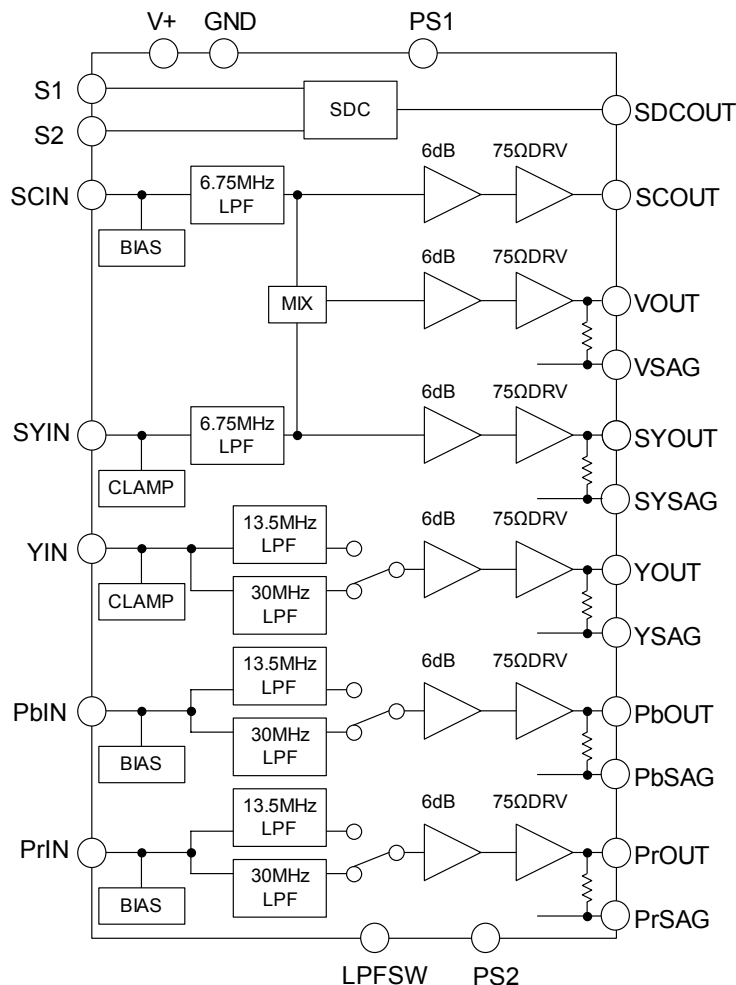

NJM2565

■ ABSOLUTE MAXIMUM RATINGS (Ta=25°C)

PARAMETER	SYMBOL	RATINGS	UNIT
Supply Voltage	V ⁺	10.0	V
Power Dissipation	P _D	1250 (Note1)	mW
Operating Temperature Range	T _{opr}	-40 to +85	°C
Storage Temperature Range	T _{stg}	-40 to +150	°C

(Note1) At on a board of EIA/JEDEC specification. (114.3 x 76.2 x 1.6mm Two layers, FR-4)

■ RECOMMENDED OPERATING CONDITION (Ta=25°C)

PARAMETER	SYMBOL	TEST CONDITION	MIN.	TYP.	MAX.	UNIT
Operating Voltage	V _{opr}		+4.5	+5.0	+5.5	V

■ ELECTRICAL CHARACTERISTICS (Ta=25°C, V⁺=5V, R_L=150Ω)

PARAMETER	SYMBOL	TEST CONDITION	MIN.	TYP.	MAX.	UNIT
Operating Current	I _{cc}	No Signal	-	55	80	mA
Operating Current at Power Save	I _{save}	Power Save Mode	-	2.0	4.0	mA
Maximum Output Voltage Swing	V _{om}	(Note 2) Vin=100kHz, Sine Signal, THD=1%	2.4	-	-	Vp-p
Voltage Gain1	G _{v1}	(Note 2) Vin=1MHz, 1.0Vp-p, Sine Signal	5.7	6.2	6.7	dB
Voltage Gain2	G _{v2}	(Note 3) Vin=3.58MHz, 0.3Vp-p, Sine Signal	5.7	6.2	6.7	dB
Gain Difference Between channel	ΔG _v	(Note 3) Vin=1MHz, 1.0Vp-p, Sine Signal	-0.2	0.0	+0.2	dB
Low Pass Filter Characteristic 1	G _f 6.75M	(Note 4) 6.75MHz/1MHz, 1.0Vp-p, Sine Signal	-1.0	0	1.0	dB
	G _f 108M	(Note 4) 108MHz/1MHz, 1.0Vp-p, Sine Signal	-	-40.0	-24.0	dB
Low Pass Filter Characteristic 2	G _f 6.75M	(Note 3) 6.75MHz/3.58MHz, 0.3Vp-p, Sine Signal	-1.0	0	1.0	dB
	G _f 108M	(Note 3) 108MHz/3.58MHz, 0.3Vp-p, Sine Signal	-	-40.0	-24.0	dB
Low Pass Filter Characteristic 3	G _{fSD} 13.5M	(Note 5) 13.5MHz/1MHz, 1.0Vp-p, Sine Signal	-1.0	0	1.0	dB
	G _{fSD} 108M	(Note 5) 108MHz/1MHz, 1.0Vp-p, Sine Signal	-	-40.0	-24.0	dB
Low Pass Filter Characteristic 4	G _{fD} 30M	(Note 5) 30MHz/1MHz, 1.0Vp-p, Sine Signal	-1.0	0	+1.0	dB
	G _{fD} 148M	(Note 5) 148MHz/1MHz, 1.0Vp-p, Sine Signal	-	-40.0	-24.0	dB
Differential Gain	DG	(Note 2) Vin=1.0Vp-p, 10step Video Signal	-	0.5	-	%
Differential Phase	DP	(Note 2) Vin=1.0Vp-p, 10step Video Signal	-	0.5	-	deg
S/N Ratio1	SN1	(Note 2) Vin=1.0Vp-p, 100% White video signal, R _L =75Ω, 100KHz to 6MHz	-	80	-	dB
S/N Ratio2	SN2	Y/C MIX, Vin=1.0Vp-p, 100% White video signal, R _L =75Ω, 100KHz to 6MHz	-	70	-	dB

Note 2 (SYIN, YIN, PbIN, PrIN) Input

Note 3 (SCIN) Input

Note 4 (SYIN) Input

Note 5 (YIN, PbIN, PrIN) Input

■ ELECTRICAL CHARACTERISTICS (Ta=25°C, V⁺= 5V, R_L=150Ω)

PARAMETER	SYMBOL	TEST CONDITION	MIN.	TYP.	MAX.	UNIT
SDC Output Voltage Low Level	SDCL	RL=10kΩ+100kΩ	-	0.1	0.5	V
SDC Output Voltage Mid Level	SDCM	RL=10kΩ+100kΩ	1.6	2.1	2.4	V
SDC Output Voltage High Level	SDCH	RL=10kΩ+100kΩ	4.3	4.6	-	V
SW Voltage High Level	VthH		2.2	-	V ⁺	V
SW Voltage Low Level	VthL		0	-	1.0	V
Switch inflow current High Level	I _{SWH}	V=5V	-	-	120	μA
Switch inflow current Low Level	I _{SWL}	V=0.3V	-	-	8.0	μA

■ CONTROL TERMINAL

PARAMETER	STATUS	NOTE
PS1 (Power Save1)	H	(SYOUT, VOUT, SCOUT) Power Save: OFF, Active
	L	(SYOUT, VOUT, SCOUT) Power Save: ON, Mute
	OPEN	(SYOUT, VOUT, SCOUT) Power Save: ON, Mute
PS2 (Power Save2)	H	(YOUT, PbOUT, PrOUT) Power Save: OFF, Active
	L	(YOUT, PbOUT, PrOUT) Power Save: ON, Mute
	OPEN	(YOUT, PbOUT, PrOUT) Power Save: ON, Mute
LPF SW (LPF)	H	30MHz LPF
	L	13.5MHz LPF
	OPEN	13.5MHz LPF

■ SDC OUT

S1	S2	SDC OUT	Aspect Ratio
L (OPEN)	L (OPEN)	0V	4:3 Normal
L (OPEN)	H	2.1V	4:3 Letter box
H	H	2.1V	4:3 Letter box
H	L (OPEN)	4.6V	16:9 Squeeze

NJM2565

■ PIN CONFIGURATION

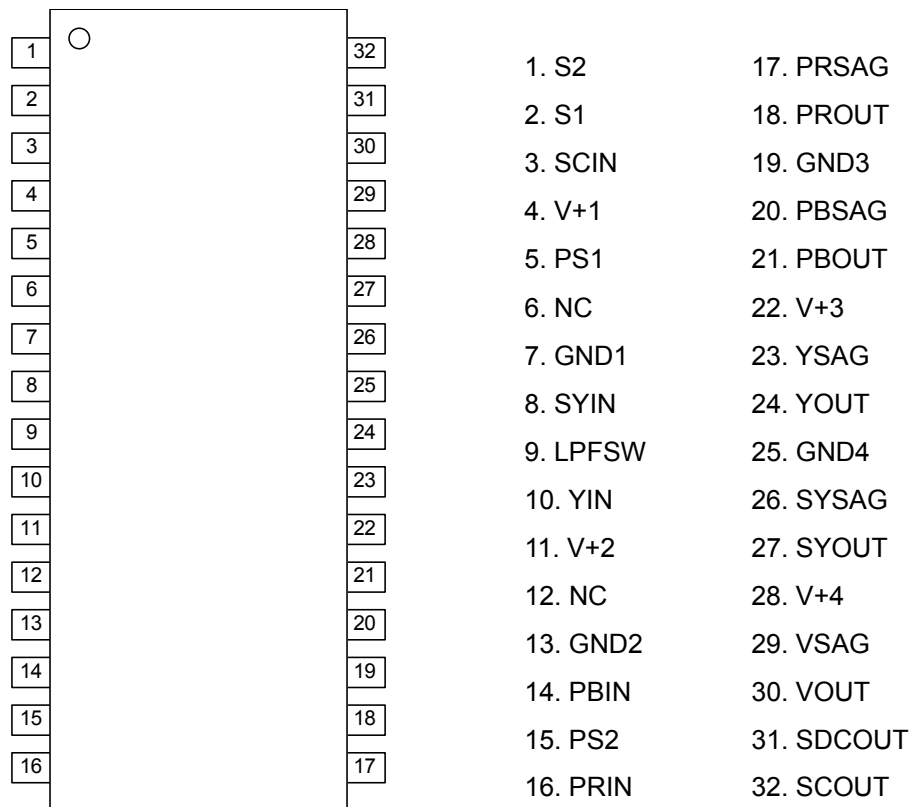

■ TERMINAL FUNCTION

PIN No.	PIN NAME	FUNCTION	EQUIVALENT CIRCUIT	DC VOLTAGE
1	S2	SDC control		-
2	S1	SDC control		
5	PS1	(SY, V, SC, SDC) Power save		
9	LPFSW	(Y, Pb, Pr) LPF control		
15	PS2	(Y, Pb, Pr) Power save		
3	SCIN	Chroma signal input		2.5V
14	PBIN	Component signal (Pb) input		
16	PRIN	Component signal (Pr) input		
8	SYIN	Y signal input		1.7V
10	YIN	Component signal (Y) input		
17	PRSAG	Component signal (Pr) sag correction		2.5V
20	PBSAG	Component signal (Pb) sag correction		
23	YSAG	Component signal (Y) sag correction		
26	SYSAG	Y signal sag correction		1.3V
29	VSAG	Composite video signal sag correction		

NJM2565

PIN No.	PIN NAME	FUNCTION	EQUIVALENT CIRCUIT	DC VOLTAGE
18	PROUT	Component signal (Pr) output		2.5V
21	PBOUT	Component signal (Pb) output		1.3V
24	YOUT	Component signal(Y) output		-
27	SYOUT	Y signal output		
30	VOOUT	Composite video signal output		
31	SDCOUT	SDC output		
32	SCOUT	Chroma signal output		2.5V

■ TEST CIRCUIT

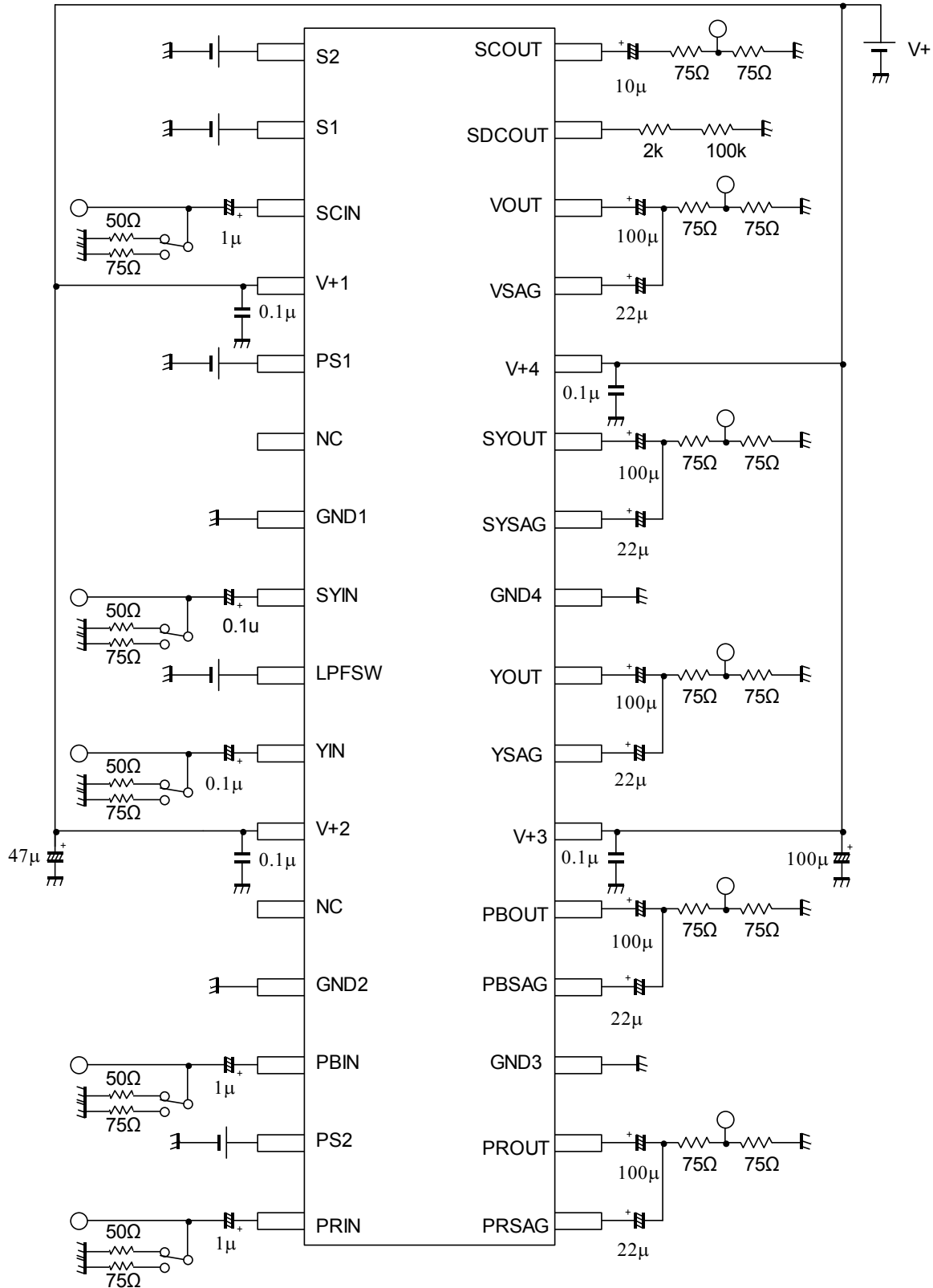

(Note) Put the bypass capacitor of 0.1μF near IC pin.

NJM2565

APPLICATION CIRCUIT

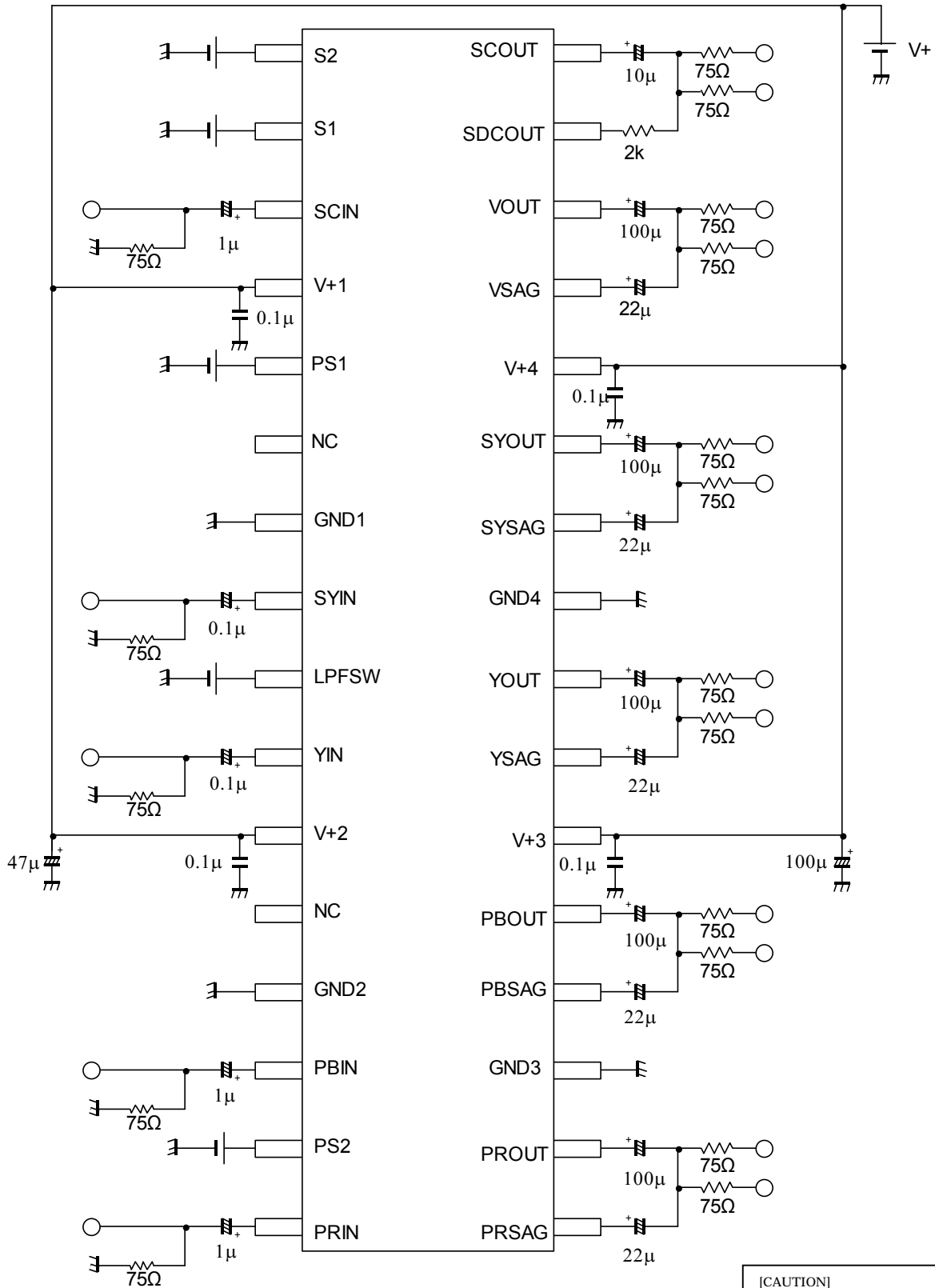

[CAUTION]
The specifications on this databook are only given for information, without any guarantee as regards either mistakes or omissions. The application circuits in this databook are described only to show representative usages of the product and not intended for the guarantee or permission of any right

(Note) Put the bypass capacitor of 0.1μF near IC pin.