

4in-1out Audio Selector with Isolation amplifier

■ GENERAL DESCRIPTION

The **NJM2754** is 4In-1out stereo audio Selector with ground noise isolation amplifiers. It contains dual channel differential amplifier.

It is developed for those car audio applications where long connections between head unit and other components are necessary and ground noise has to be eliminated.

■ PACKAGE OUTLINE

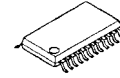

NJM2754V

■ FEATURES

- 4in-1out Stereo Audio Selector
- Operating Voltage 4.3 to 12V
- Operating Current 14mA(typ.)
- Common mode rejection ratio CMRR=60dB typ.
- Maximum Output Voltage 2Vrms min., @ THD=0.1%
- Supply Voltage Rejection Ratio 60dB typ.
- Total Harmonic Distortion 0.003% typ.
- Noise Output Voltage 1.7 μ Vrms typ.
- Bipolar Technology
- Package Outline SSOP20

■ BLOCK DIAGRAM

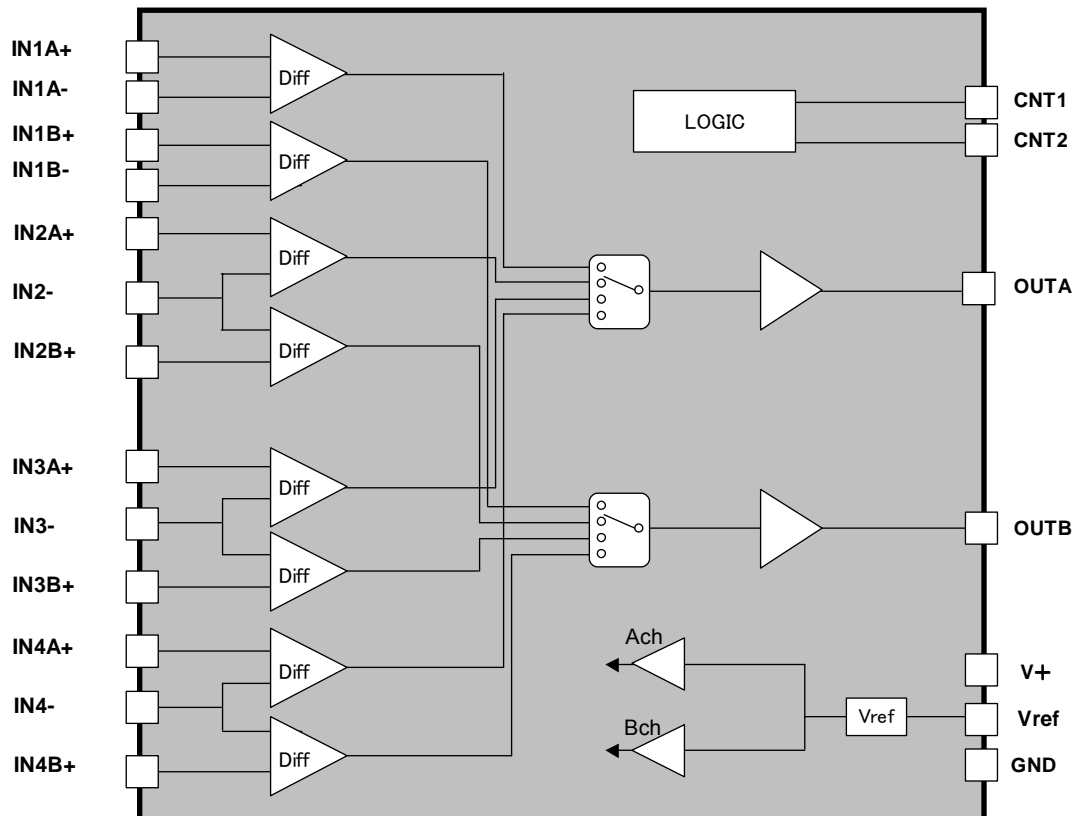

NJM2754

www.DataSheet4U.com

■PIN CONFIGURATION

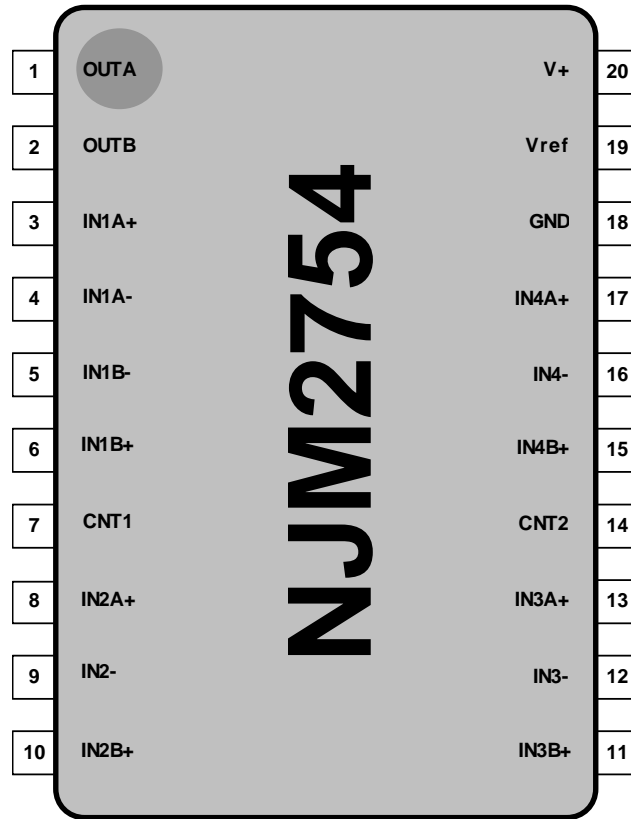

| No. | SYMBOL | FUNCTION |
|-----|--------|-------------------|
| 1 | OUTA | Ach Output |
| 2 | OUTB | Bch Output |
| 3 | IN1A+ | Ach +Input 1 |
| 4 | IN1A- | Ach -Input1 |
| 5 | IN1B- | Bch -Input1 |
| 6 | IN1B+ | Bch +Input 1 |
| 7 | CNT1 | CONTROL 1 |
| 8 | IN2A+ | Ach +Input 2 |
| 9 | IN2- | -Input2 |
| 10 | IN2B+ | Bch +Input 2 |
| 11 | IN3B+ | Bch +Input 3 |
| 12 | IN3- | -Input3 |
| 13 | IN3A+ | Ach +Input 3 |
| 14 | CNT2 | CONTROL 2 |
| 15 | IN4B+ | Bch +Input 4 |
| 16 | IN4- | -Input4 |
| 17 | IN4A+ | Ach +Input 4 |
| 18 | GND | Ground |
| 19 | Vref | Reference Voltage |
| 20 | V+ | Power Supply |

■ABSOLUTE MAXIMUM RANGES (Ta=25°C)

| PARAMETER | SYMBOL | RANGE | UNIT |
|-----------------------|-----------------|---|------|
| Supply Voltage | V ⁺ | +15 | V |
| Maximum Input Voltage | V _{IM} | 0 to V ⁺ (*) | V |
| Power Dissipation | P _D | SSOP20 : 700 ⁽¹⁾ 950 ⁽²⁾ <small>(1) EIA/JEDEC STANDARD Test board (76.2x114.3x1.6mm, 2layer, FR-4) mounting (2) EIA/JEDEC STANDARD Test board (76.2x114.3x1.6mm, 4layer, FR-4) mounting</small> | mW |
| Operating Temperature | Topr | -40 to +85 | °C |
| Storage Temperature | Tstg | -40 to +150 | °C |

■ELECTRICAL CHARACTERISTIC (V⁺=9V, Ta=25°C)

| PARAMETER | SYMBOL | TEST CONDITION | MIN. | TYP. | MAX. | UNIT |
|--|------------------|---|------|-------|----------------|-------------------|
| DC CHARACTERISTIC | | | | | | |
| Operating Voltage | V ⁺ | | 4.3 | 9 | 12 | V |
| Operating Current | I _{CC} | No Signal | - | 14 | 20 | mA |
| Reference Voltage | V _{REF} | | 3.8 | 4.3 | 4.8 | V |
| AC CHARACTERISTIC (Non-inverting circuit, f=1kHz, V _{in} =1V _{rms} , R _g =0Ω, R _L =10kΩ unless otherwise specified) | | | | | | |
| Voltage Gain | G _V | | -1.0 | 0.0 | +1.0 | dB |
| Cross Talk | CT | f=1kHz, A-Weighted | 100 | 110 | - | dB |
| Channel Separation | CS | f=1kHz, A-Weighted | 90 | 110 | - | dB |
| Channel Balance | BAL | | - | - | 0.5 | dB |
| Roll-off High Frequency | f _{RH} | -1dB | 100 | - | - | kHz |
| Input Resistance | R _{IN} | | 85 | 105 | 125 | kΩ |
| Output Resistance | R _{OUT} | | - | 90 | - | Ω |
| Maximum Output Voltage | V _{OM} | THD=0.1%, f = 1kHz | 2 | 2.5 | - | V _{rms} |
| Noise Output Voltage | V _{NO} | Rg=600Ω, A-weighted | - | 1.7 | 2.5 | μV _{rms} |
| Total Harmonic Distortion | THD | f=1kHz, V _{IN} =1V _{rms} , BW=400Hz to 30kHz | - | 0.003 | 0.01 | % |
| Common Mode Rejection Ratio | CMRR | | 50 | 60 | - | dB |
| Common Mode Input Voltage | V _{icm} | CMRR=50dB | - | 2 | - | V _{rms} |
| Supply Voltage Rejection Ratio | SVR | f=100Hz, V _{ripple} =100mV _{rms} | 55 | 65 | - | dB |
| Switch-ON Voltage Level | V _{CH} | V _{CNT} =High Level | 2.3 | - | V ⁺ | V |
| Switch-OFF Voltage Level | V _{CL} | V _{CNT} =Low Level | - | - | 0.8 | V |

■SWITCH CONTROL LOGIC

| CNT2 | CNT1 | Input Ach / Bch |
|------|------|-----------------|
| L | L | 1 |
| L | H | 2 |
| H | L | 3 |
| H | H | 4 |

APPLICATION CIRCUIT

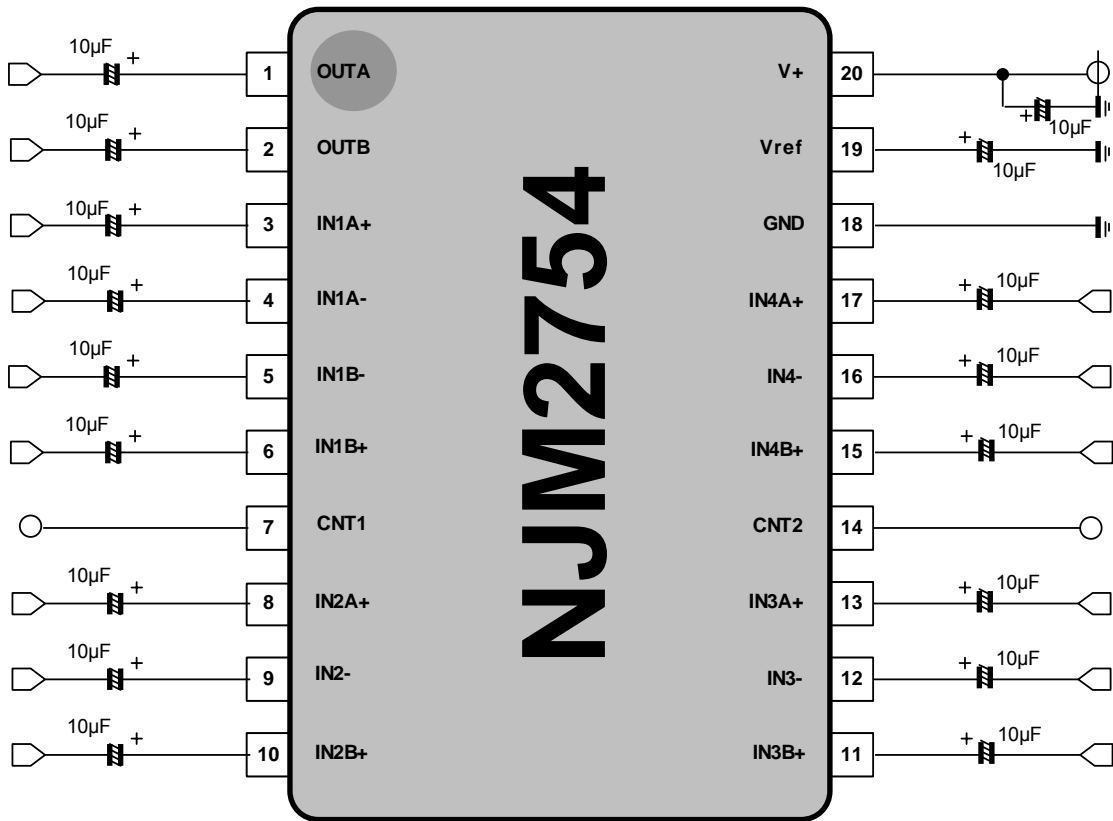

TYPICAL CHARACTERISTICS

ICC vs Supply Voltage
No signal

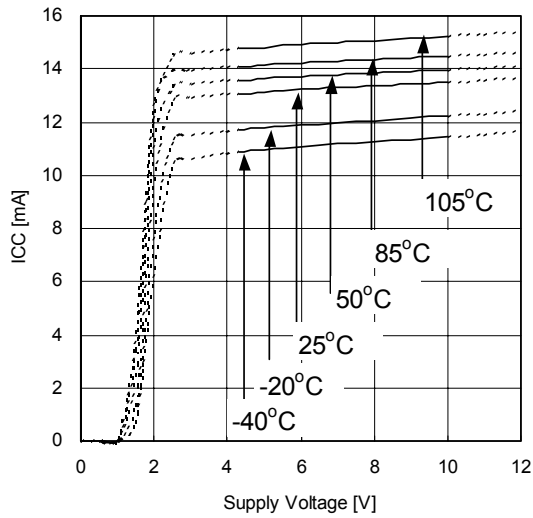

Vref vs Supply Voltage
No signal, T=105,85,50,25,-20,-40°C

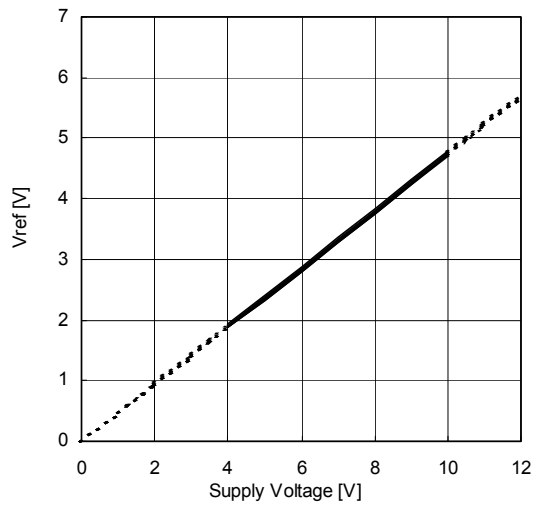

Gain Output vs Frequency
V^r=9V, V_{in}=1V_{rms}, INA1-Aout, Non-Inverting circuit
T=105,85,50,25,-20,-40°C

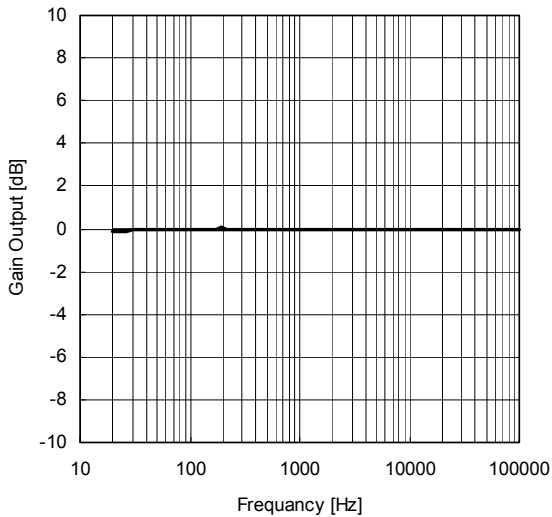

Volume Gain output vs Frequency
V^r=9V, V_{in}=1V_{rms}, INA1-Aout, Inverting circuit
T=105,85,50,25,-20,-40°C

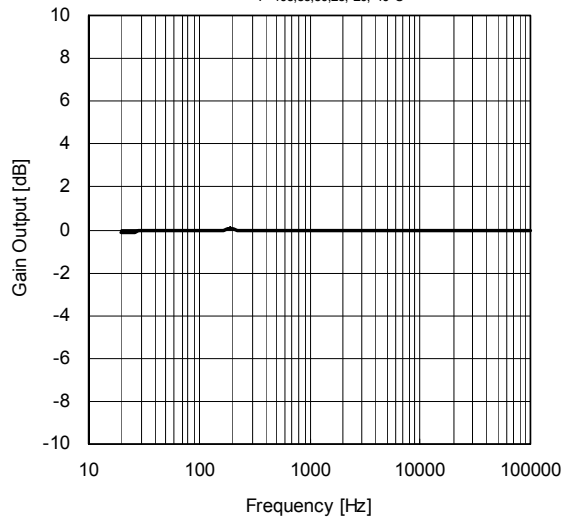

Maximum Output Voltage vs Supply Voltage
V^r=+9V, THD=0.1%, INA1-Aout, Non-Inverting circuit.
T=105,85,50,25,-20,-40°C

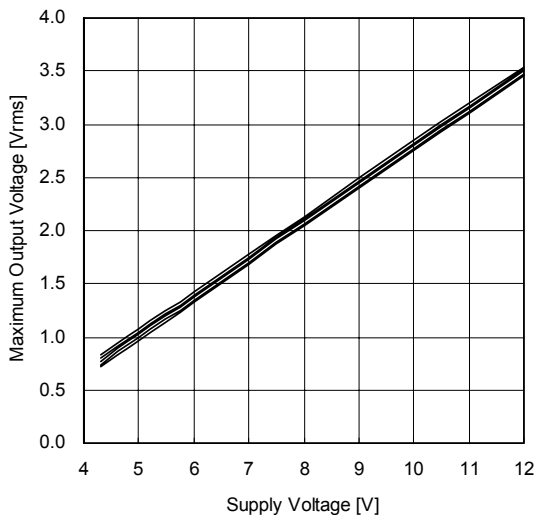

Maximum Output Voltage vs Supply Voltage
V^r=+9V, THD=0.1%, I/O: INA1-Aout, Reversing circuit
T=105,85,50,25,-20,-40°C

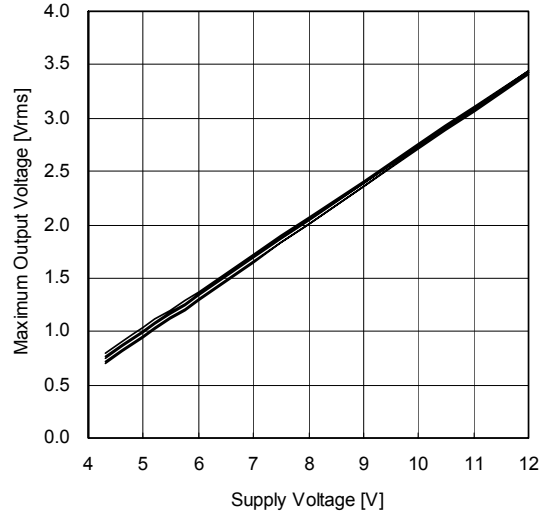

TYPICAL CHARACTERISTICS

CMR vs Frequency
 $V=+9V, V_{in}=1V_{rms}, O_{UT,A}$
 $T=105,85,50,25,-20,-40^{\circ}C$

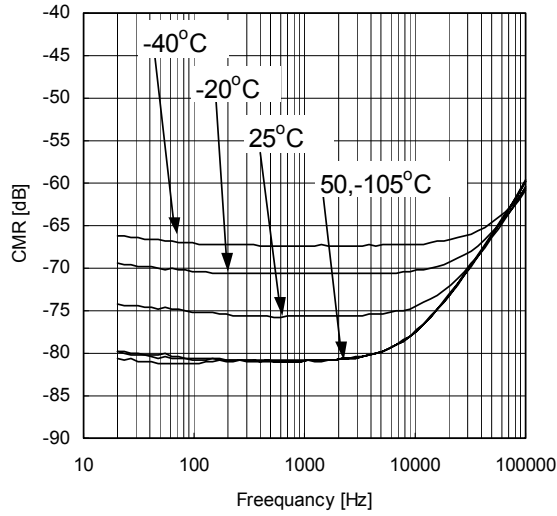

CMR vs Input Voltage
 $V=+9V, f=1kHz, BW:400Hz-30kHz, O_{UT,A}$
 $T=105,85,50,25,-20,-40^{\circ}C$

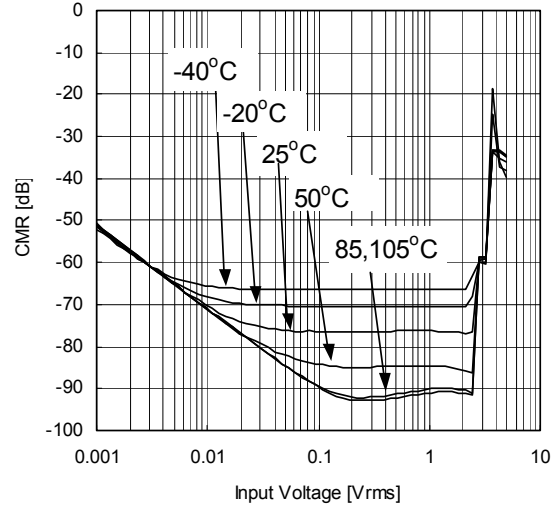

Channel Separation vs Frequency
 $V=+9V, V_{in}=1V_{rms}, BW:10-80kHz, I/O: INB1+-outA$
 Non-reversing circuit, $T=105,85,50,25,-20,-40^{\circ}C$

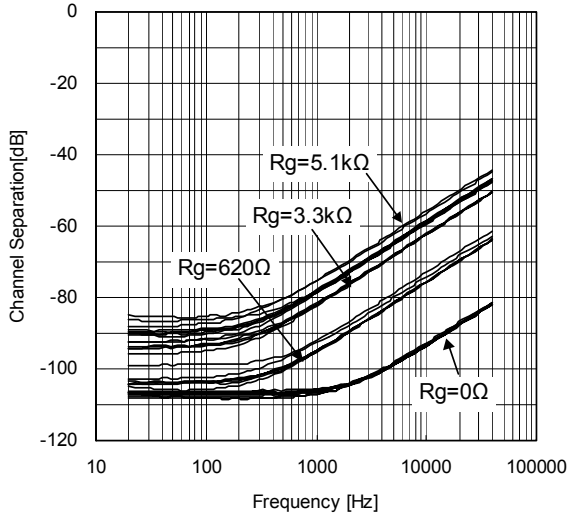

Channel Separation vs Frequency
 $V=+9V, V_{in}=1V_{rms}, BW:10-80kHz, I/O: INB1+-outA$
 Reversing circuit, $T=105,85,50,25,-20,-40^{\circ}C$

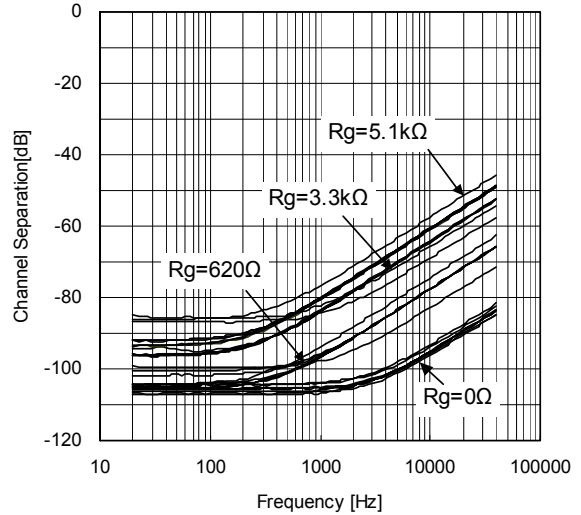

Cross Talk vs Frequency
 $V=+9V, V_{in}=1V_{rms}, BW:10-80kHz, \text{Non-reversing circuit}$
 $I/O: INA2+, INA3+, INA4+, OutA, T=105,85,50,25,-20,-40^{\circ}C$

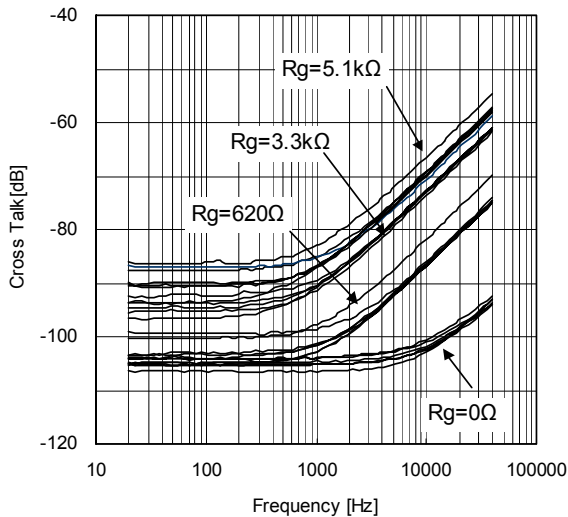

Cross Talk vs Frequency
 $V=+9V, V_{in}=1V_{rms}, BW:10-80kHz, \text{Reversing circuit}$
 $I/O: INA2-, INA3-, INA4-, OutA, T=105,85,50,25,-20,-40^{\circ}C$

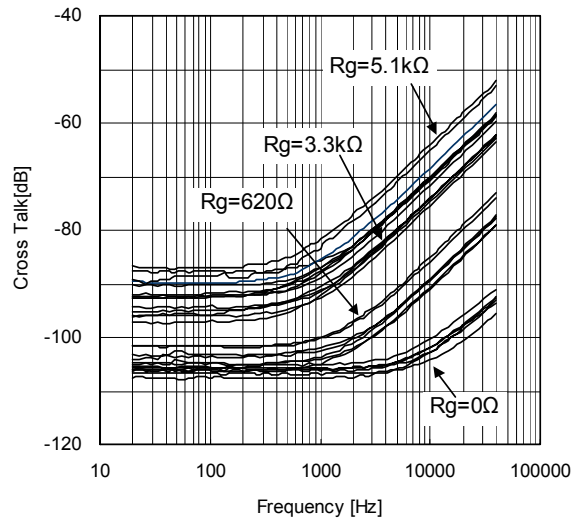

TYPICAL CHARACTERISTICS

THD+N vs Input Voltage (Non-reversing circuit)

V=+9, BW:10-22kHz(f=100Hz), 400-30kHz(f=1kHz, 10kHz),
I/O: INA1+,/OutA, T=105,85,50,25,-20,-40°C

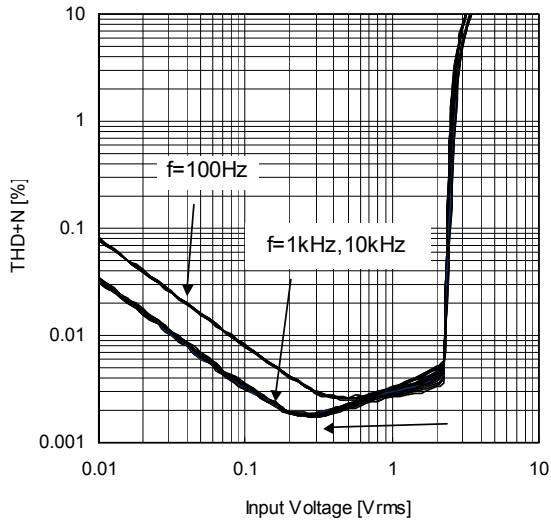

THD+N vs Input Voltage (Reversing circuit)

V=+9V, BW:10-22kHz(f=100Hz), 400-30kHz(f=1kHz, 10kHz),
I/O: INA1-,/OutA, T=105,85,50,25,-20,-40°C

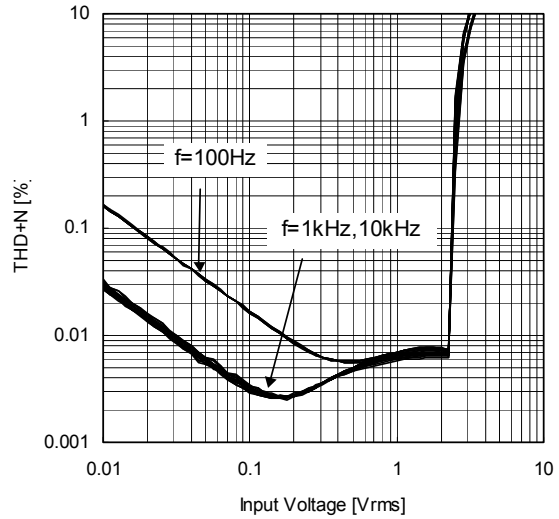

THD+N vs Frequency

V=+9V, f=1kHz, BW:10-80kHz, Vin=1Vrms,
I/O: INA1-1Aout, T=105,85,50,25,-20,-40°C

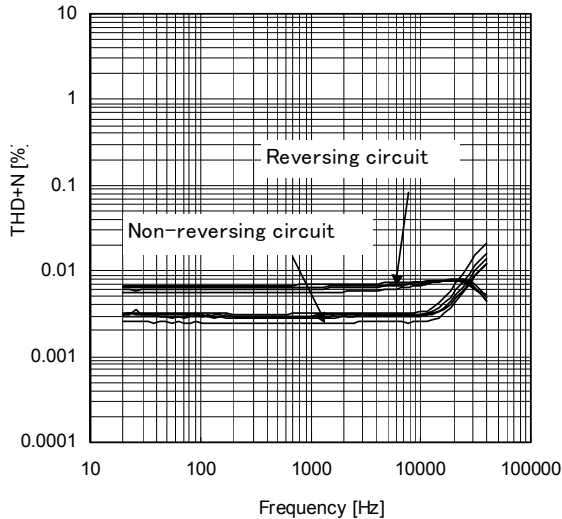

RippleRejection vs Frequency

Vrp=100mV, f=100Hz, Rg=600Ω, V=+9V, T=25°C

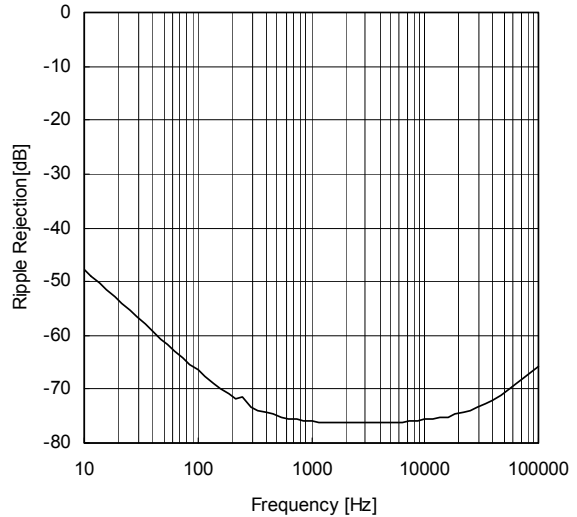

RippleRejection vs Supply Voltage

Vrip=100mV, f=100Hz, T=25°C

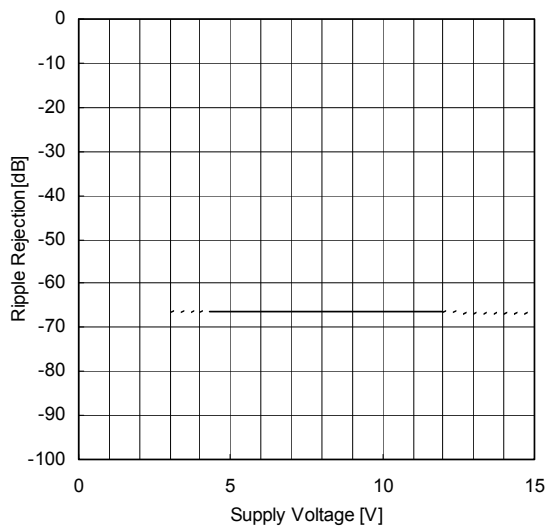

RippleRejection vs Signal source resistance

V=+9V, Vrp=100mV, f=100Hz, T=25°C

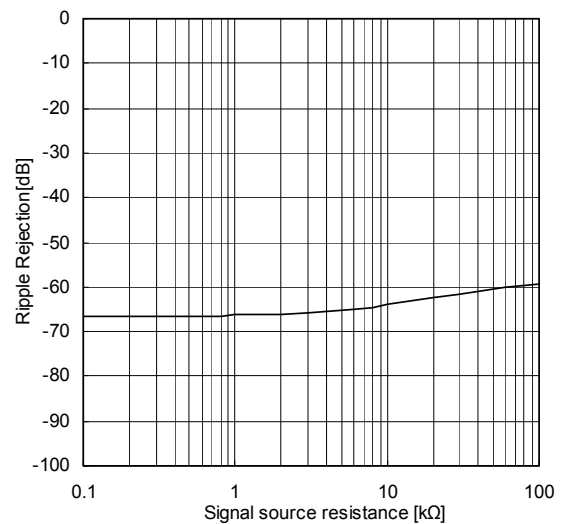

TYPICAL CHARACTERISTICS

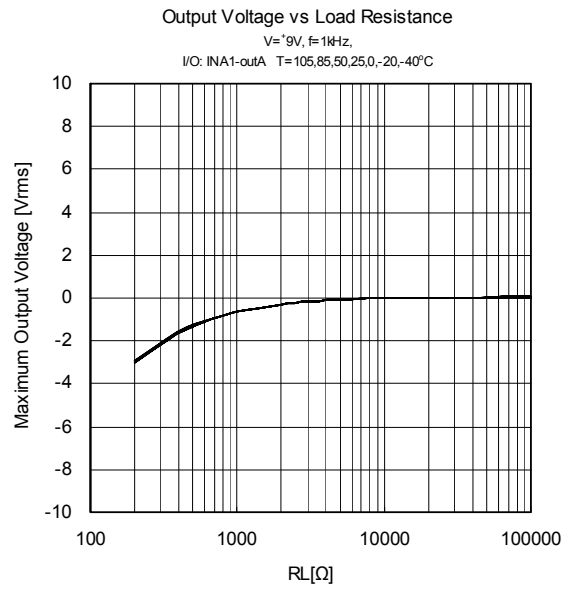
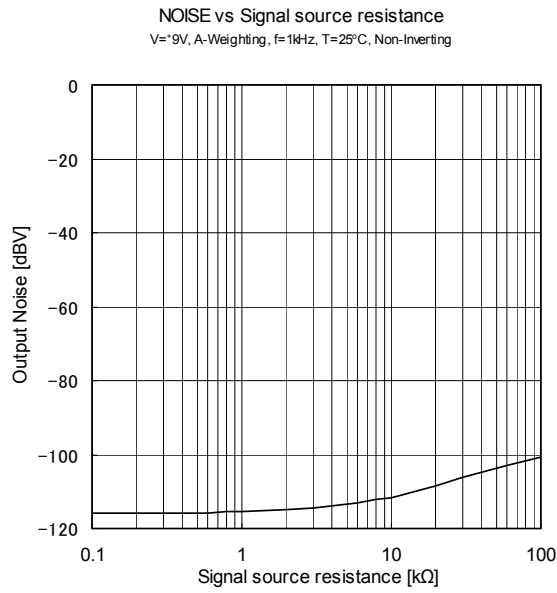

[CAUTION]
 The specifications on this databook are only given for information, without any guarantee as regards either mistakes or omissions. The application circuits in this databook are described only to show representative usages of the product and not intended for the guarantee or permission of any right including the industrial rights.