

DC-coupling 4-channel Video Driver with Auto Power Save Function

■ GENERAL DESCRIPTION

The **NJM41042** is a single supply voltage 4ch Video amplifier with SD/ HD LPF. No need output capacitor due to DC-coupling output. **NJM41042** has Auto Power Save function, which detects connecting cable or not. It realizes lower power consumption.

■ PACKAGE OUTLINE



NJM41042VC3

■ APPRICATION

- BD/DVD player
- Home Theater
- Set Top Box
- AV receiver

■ FEATURES

- Operating Voltage 4.5 to 5.5V
- Auto Power Save Function
- Composite/ Component Video Signal Input
- SD/HD LPF 6.75MHz/37MHz
- DC-coupled Output
- AC-coupled Input with Sync-tip Clamp(VIN/YIN), Bias(PbIN/PrIN)
- 6dB amplifier
- 75Ω Driver Circuit (Two-line drive)
- Monitoring Function (RL_SD,RL_HD)
- Bipolar Technology
- Package Outline SSOP20-C3

■ BLOCK DIAGRAM

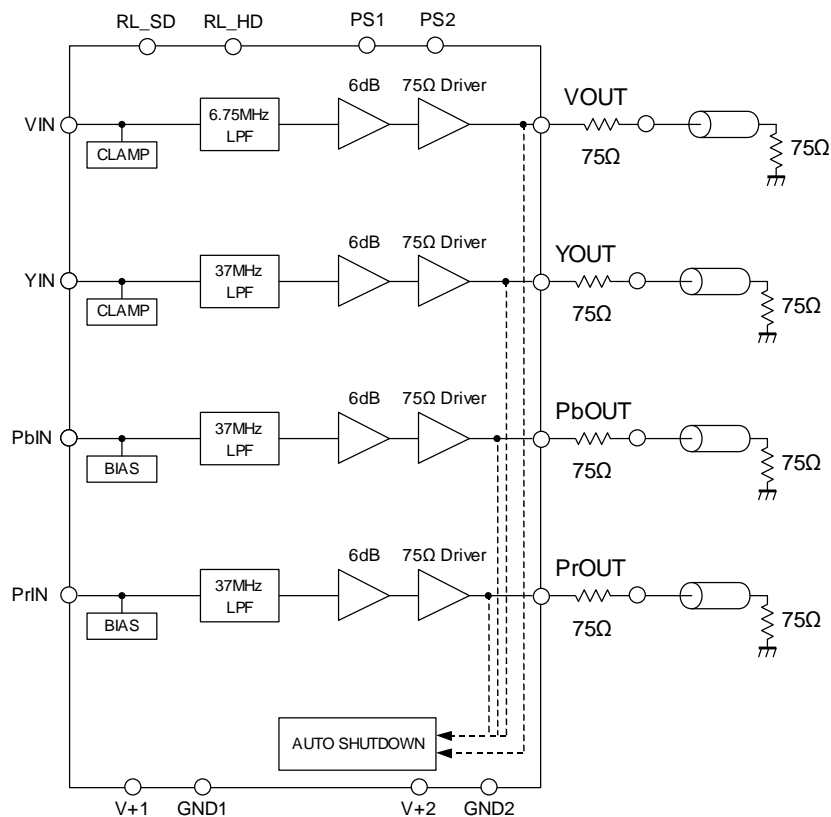

■ ABSOLUTE MAXIMUM RATINGS (Ta=25°C)

PARAMETER	SYMBOL	RATINGS	UNIT
Supply Voltage	V ⁺	7.0	V
Power Dissipation	P _D	1500 (Note 1)	mW
Operating Temperature Range	T _{opr}	-40 to +85	°C
Storage Temperature Range	T _{stg}	-40 to +150	°C

(Note 1) At on a board of EIA/JEDEC specification. (114.3 x 76.2 x 1.6mm 4 layers, FR-4)

■ RECOMMENDED OPERATING CONDITION (Ta=25°C)

PARAMETER	SYMBOL	TEST CONDITION	MIN.	TYP.	MAX.	UNIT
Operating Voltage	V _{opr}		4.5	5.0	5.5	V

■ ELECTRICAL CHARACTERISTICS (Ta=25°C, V⁺=5V, R_L=150Ω)

PARAMETER	SYMBOL	TEST CONDITION	MIN.	TYP.	MAX.	UNIT
Operating Current	I _{CC}	No Signal	-	50	70	mA
Operating Current at Power Save 1	I _{save1}	V,Y,Pb,Pr OUT: Power Save Mode PS1:ON,PS2:ON	-	0.5	1.1	mA
Operating Current at Power Save 2	I _{save2}	VOUT: Power Save Mode PS1:ON,PS2:OFF	-	45	60	mA
Operating Current at Power Save 3	I _{save3}	Y,Pb,Pr OUT: Power Save Mode PS1:OFF,PS2:ON	-	10	15	mA
Maximum Output Voltage Swing	V _{om}	V,Y,Pb,Pr IN=100kHz, Sine Signal, THD=1%	2.4	-	-	Vp-p
Output DC Voltage1	V _{o1}	VOUT/YOUT terminal voltage	0.3	0.5	0.7	V
Output DC Voltage2	V _{o2}	PbOUT/PrOUT terminal voltage	1.4	1.7	2.0	V
Voltage Gain	G _v	V,Y,Pb,Pr IN=1MHz, 1.0Vp-p, Sine Signal	5.5	6.0	6.5	dB
Low Pass Filter Characteristic 1	G _{fy6.75M}	(Note 1) 6.75MHz/1MHz, 1.0Vp-p, Sine Signal	-1.0	0	1.0	dB
	G _{fy108M}	(Note 1) 108MHz/1MHz, 1.0Vp-p, Sine Signal	-	-40.0	-24.0	dB
Low Pass Filter Characteristic 2	G _{f_{HD}37M}	(Note 2) 37MHz/1MHz, 1.0Vp-p, Sine Signal	-	-3.0	-	dB
	G _{f_{HD}148M}	(Note 2) 148MHz/1MHz, 1.0Vp-p, Sine Signal	-	-40.0	-24.0	dB
Differential Gain	DG	(Note 3) 1.0Vp-p, 10step Video Signal	-	0.5	-	%
Differential Phase	DP	(Note 3) 1.0Vp-p, 10step Video Signal	-	0.5	-	deg
S/N Ratio	SN	(Note 3) 1.0Vp-p, 100% White video signal, R _L =75Ω, 100KHz to 6MHz	-	80	-	dB
SW Voltage High Level	V _{thH}		2.2	-	V ⁺	V
SW Voltage Low Level	V _{thL}		0	-	1.0	V
Switch inflow current High Level	I _{thH}	V=5V	-	-	120	μA
Switch inflow current Low Level	I _{thL}	V=0.3V	-	-	8.0	μA
RL Voltage High Level	V _{thH}	R=10kΩ	0.7* V ⁺	-	V ⁺	V
RLSW Voltage Low Level	V _{thL}	R=10kΩ	0	-	0.3* V ⁺	V

(Note 1) V Input, (Note 2) Y,Pb,Pr Input, (Note 3) V,Y Input

■ CONTROL TERMINAL

PARAMETER	STATUS	NOTE
PS SW 1 (Vout Power Save)	H	VOUT Power Save: OFF (Active)
	L	VOUT Power Save: ON (Mute)
	OPEN	VOUT Power Save ON(Mute)
PS SW 2 (Y,Pb,PrPower Save)	H	Y,Pb,Pr OUT Power Save: OFF (Active)
	L	Y,Pb,Pr OUT Power Save: ON (Mute)
	OPEN	Y,Pb,Pr OUT Power Save ON(Mute)

■ MONITOR TERMINAL

PARAMETER	STATUS	NOTE
RL_SD	H	VOUT No Connection
	L	VOUT Connected
RL_HD	H	Y,Pb,Pr OUT No Connection
	L	Y,Pb,Pr OUT Connected

NJM41042 has the load detecting function.

Terminal (SD, HD) with which the cable is connected operates.

It auto shutdown mode when there is no load (open mode).

SD and HD operate independently.

Monitor pin is outputs to see that if the video amplifier is operating.

It can be judged whether the cable is connected by feedback this terminal information to the microcomputer.

■ TEST CIRCUIT

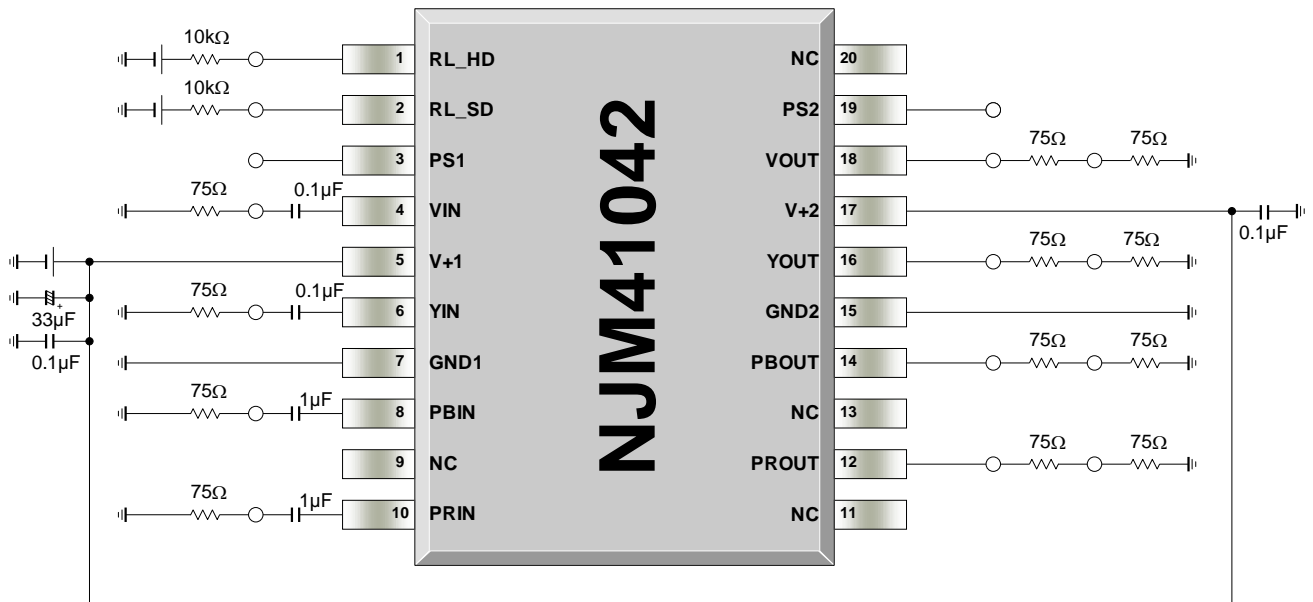

We recommend the DC termination of 75Ω.

When the AC termination, there is a possibility that the signal is not correctly outputted.

■ APPRICATION CIRCUIT 1

We recommend the DC termination of 75Ω.

When the AC termination, there is a possibility that the signal is not correctly outputted.

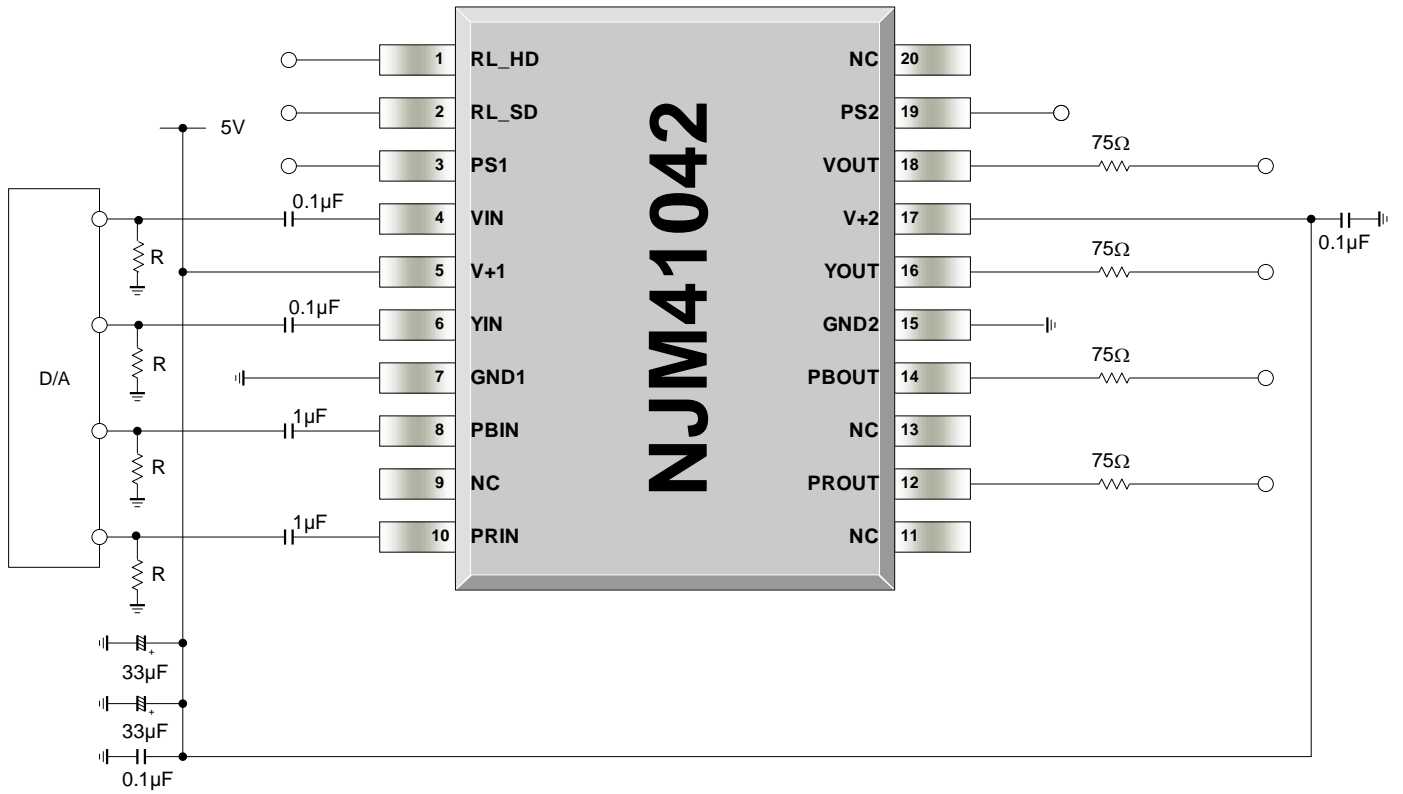

■ APPRICATION CIRCUIT 2 (2-line Drive)

We recommend the DC termination of 75Ω.

When the AC termination, there is a possibility that the signal is not correctly outputted.

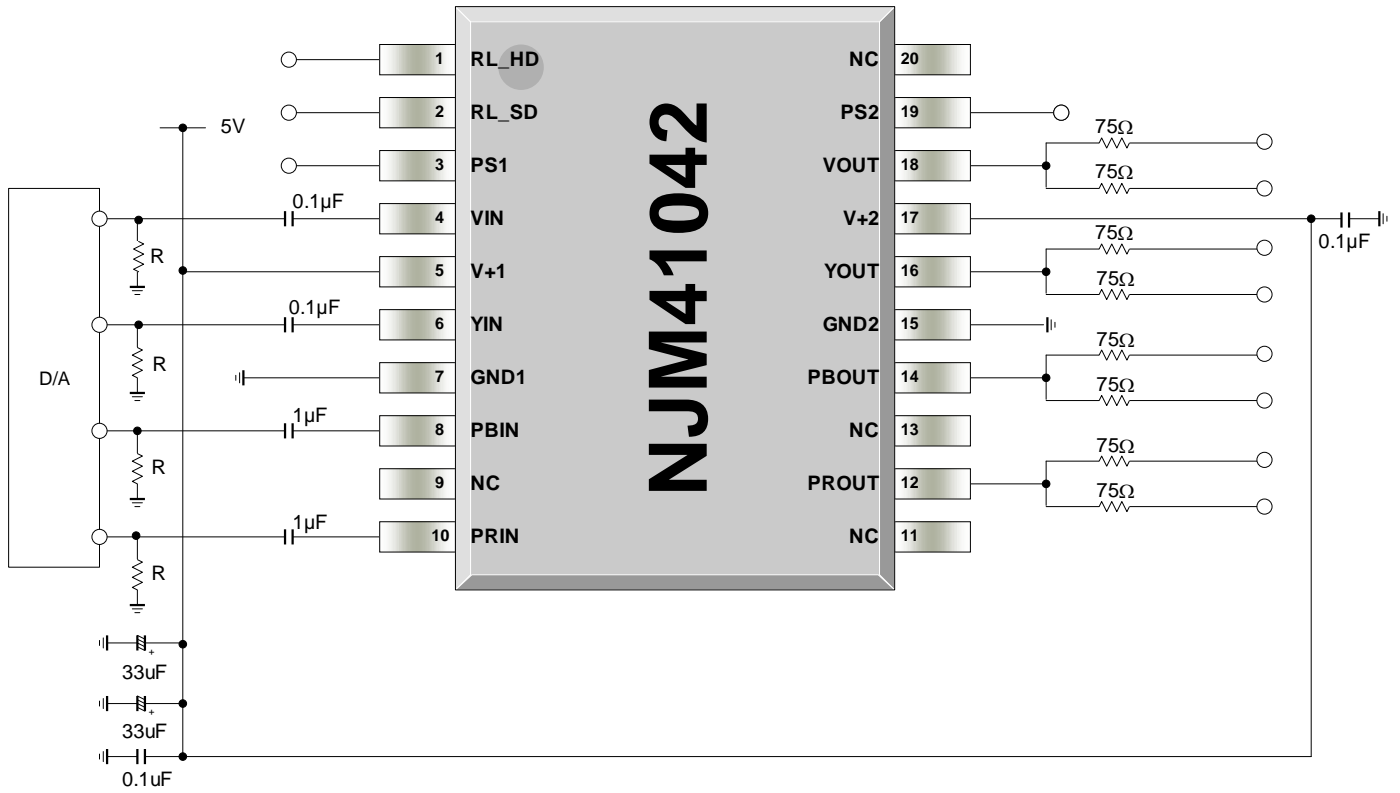

■ TYPICAL CHARACTERISTICS

Frequency response 6.75MHz

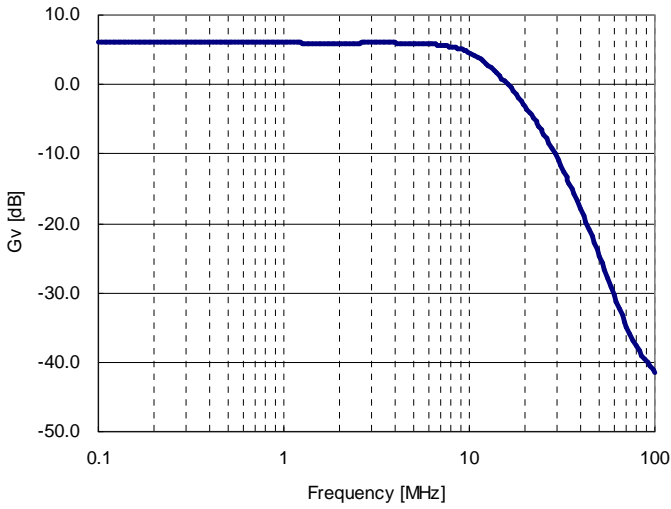

Frequency response 37MHz

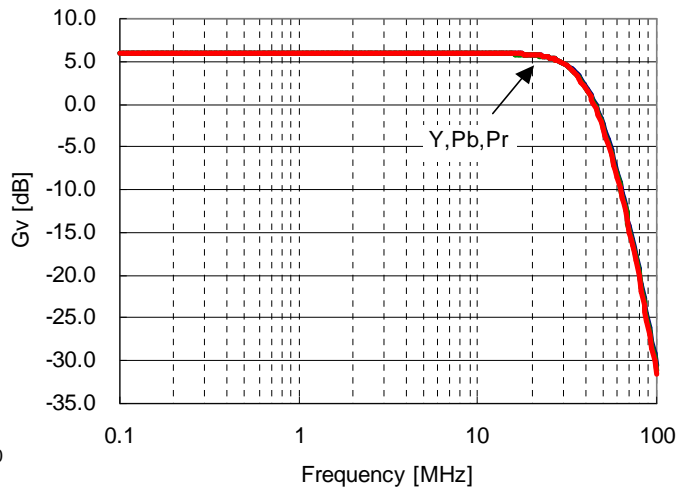

Frequency response 6.75MHz

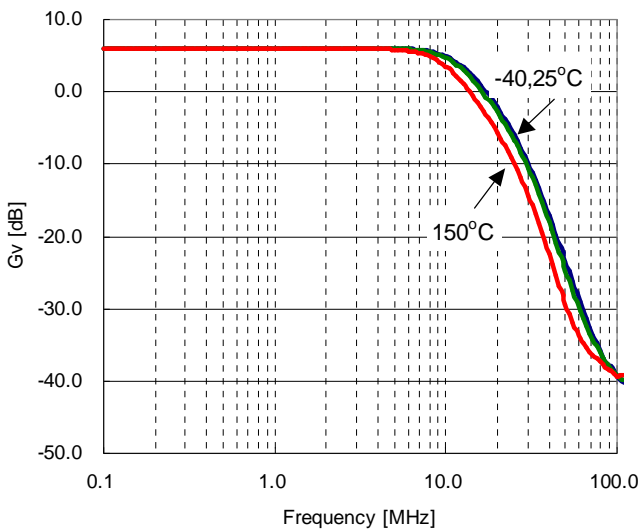

Frequency response 37MHz

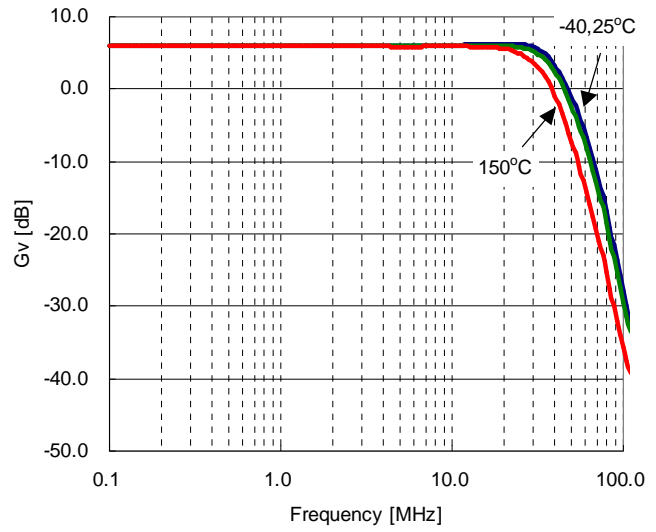

Group Delay 6.75MHz

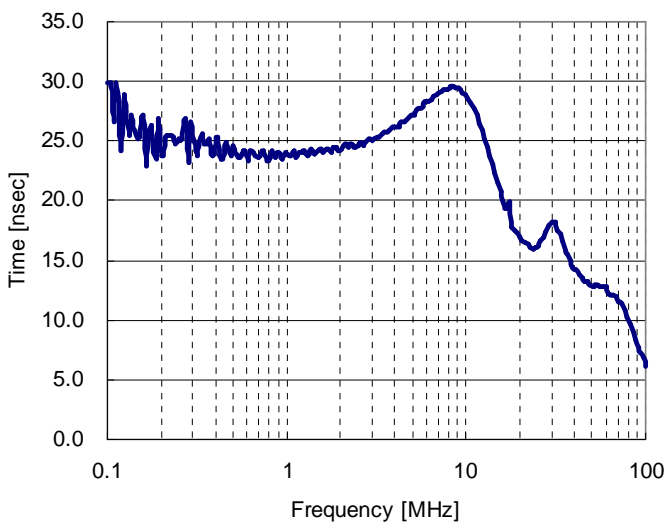

Group Delay 37MHz

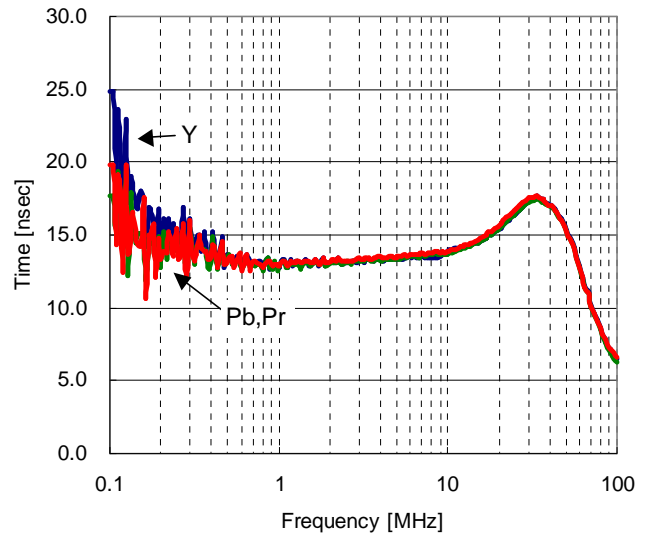

■ TYPICAL CHARACTERISTICS

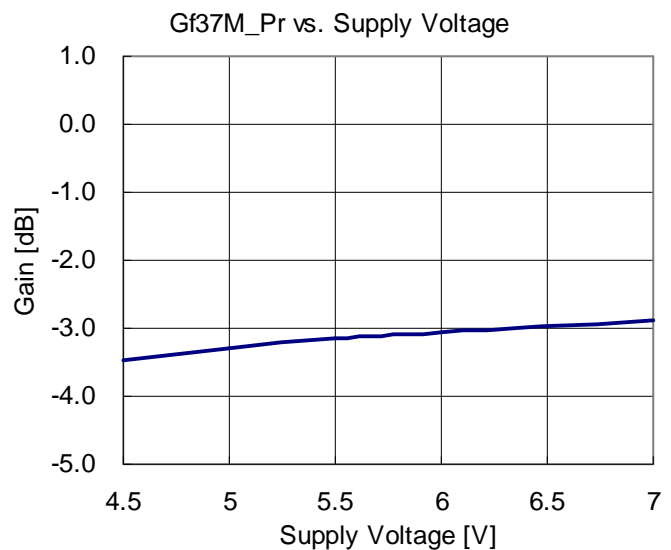
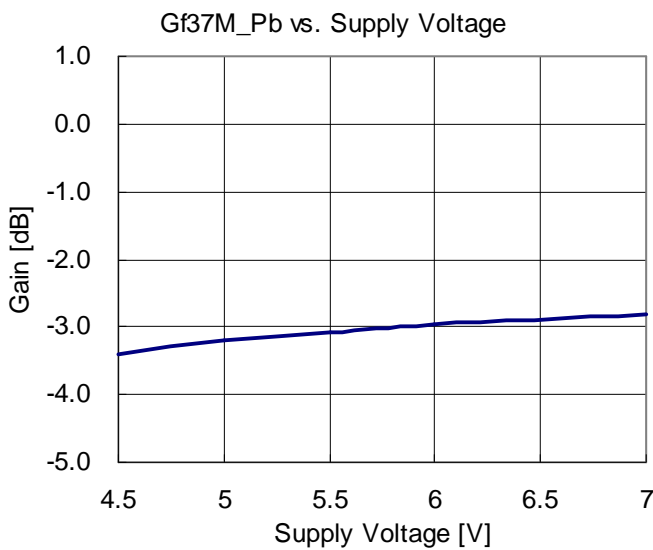
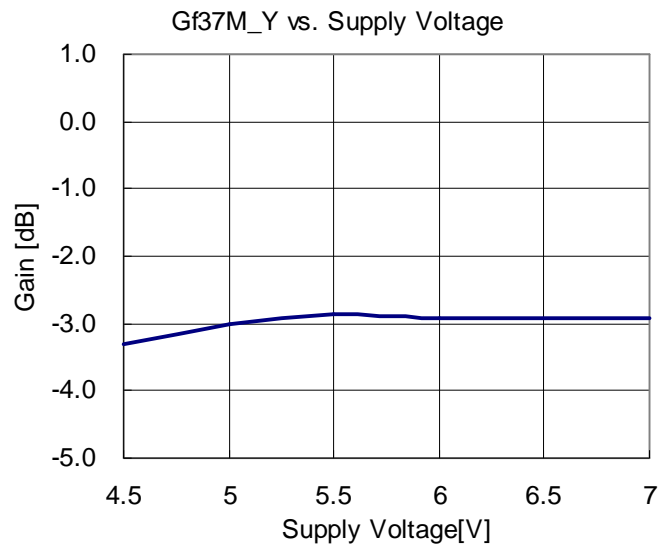
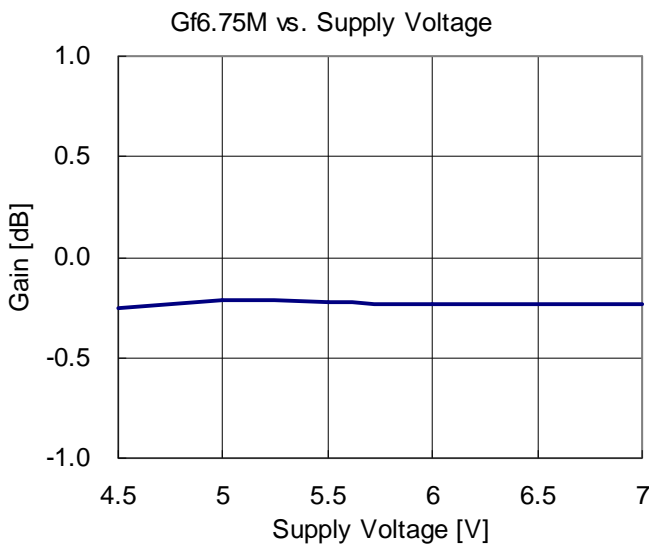
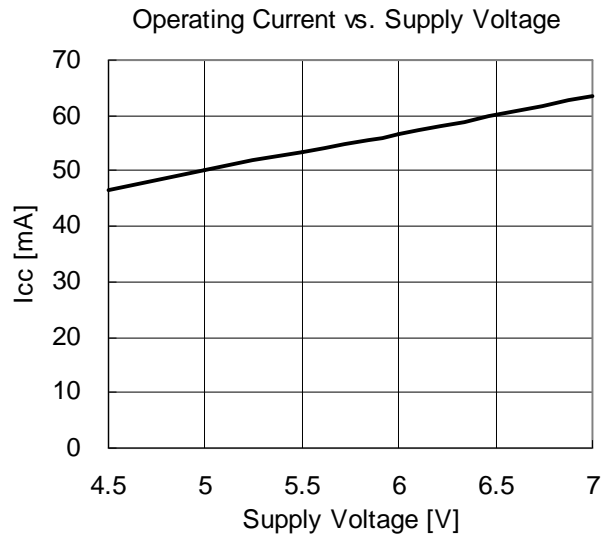
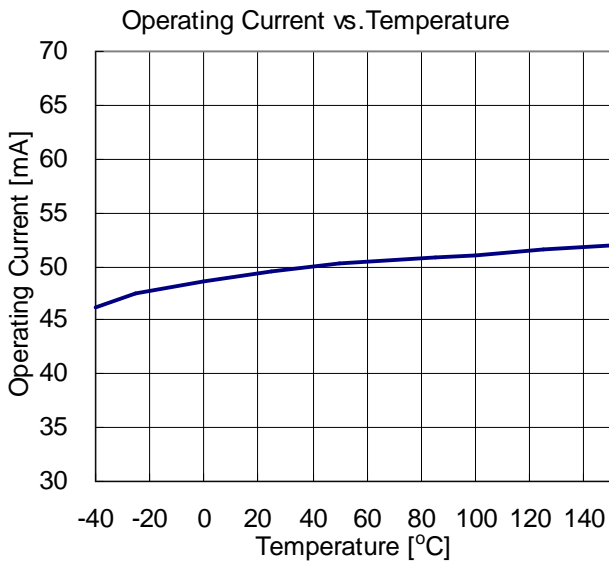

■ TYPICAL CHARACTERISTICS

Differential Gain vs. Temperature

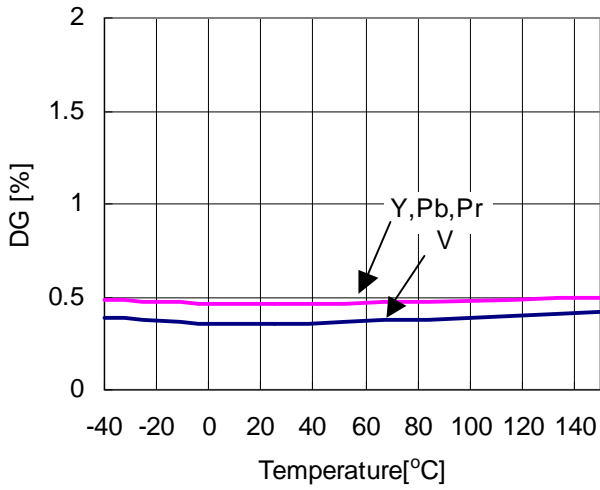

Differential Phase vs. Temperature

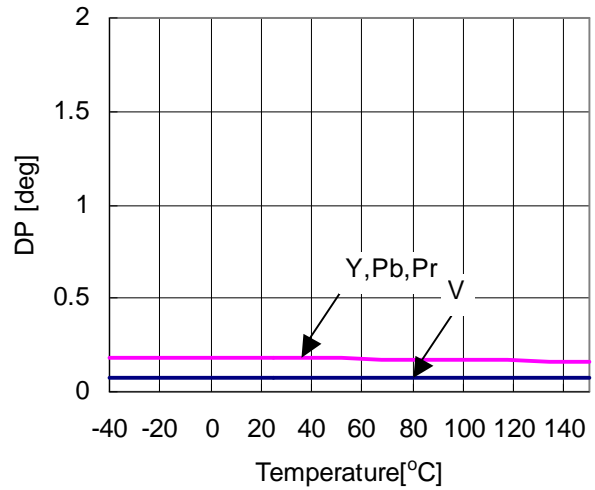

Maximum Output Voltage vs. Temperature

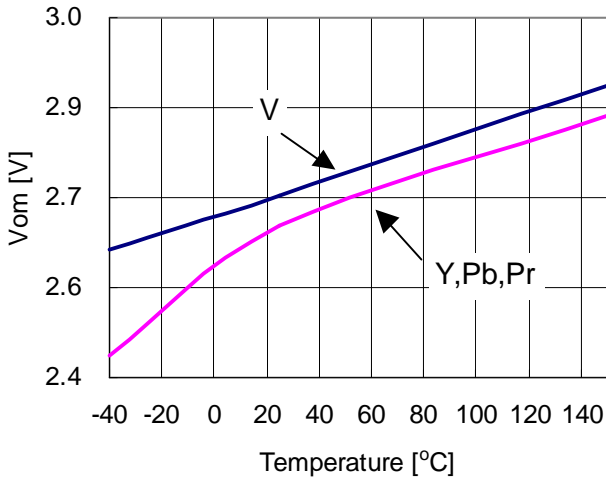

S/N ratio vs. Temperature

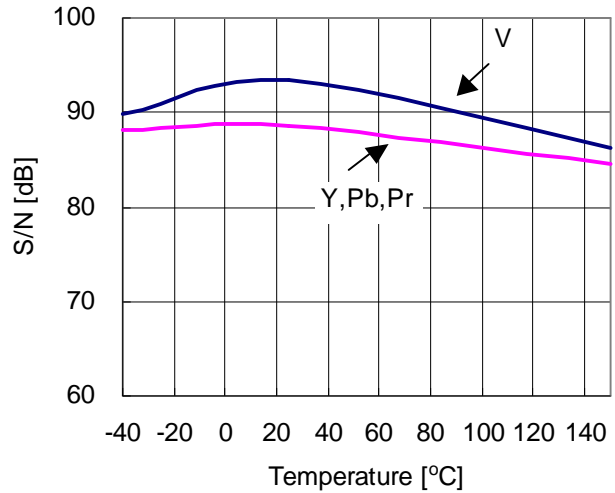

Cross Talk vs. Operating Voltage

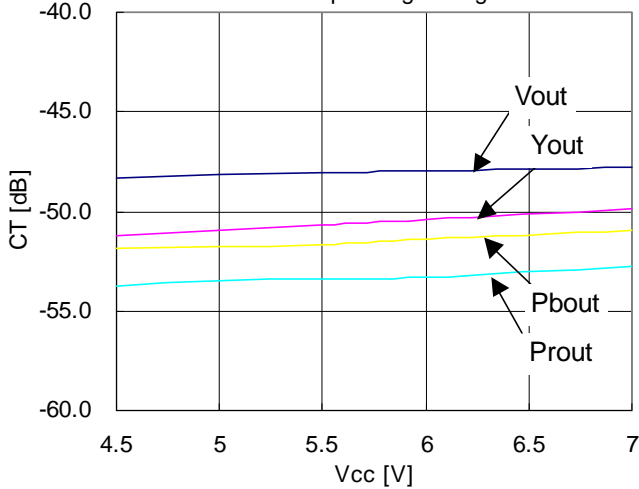

[CAUTION]

The specifications on this databook are only given for information, without any guarantee as regards either mistakes or omissions. The application circuits in this databook are described only to show representative usages of the product and not intended for the guarantee or permission of any right including the industrial rights.