



SRS Circle SurroundII5.1 & Passive Matrix TruSurround HD/HD4XT Decoder

■ Package



NJU26150-19A

■ General Description

The NJU26150-19A is a digital signal processor that provides the function of Circle SurroundII5.1 / TruSurround HD/HD4.

The NJU26150-19A processes the stereo matrix-encoded signal into spacious sound of 5.1 channels by Circle SurroundII5.1. Also non matrix-encoded audio signal can be processed into effective spacious sound.

The NJU26150-19A is also possible surround sound reproduction by Passive Matrix TruSurround HD/HD4 technology, even if it is not only the independent 5.1ch speaker configuration but also the front speaker configuration.

■ FEATURES

- Software

- 5.1-Channel signal outputs by SRS Circle Surround II 5.1
- Front Multi channel outputs by SRS TruSurround HD/ TruSurround HD4
- Input : Lt/Rt only TruSurround HD(2ch to 3.1ch outputs), TruSurround HD4(4ch to 5.1ch outputs)
- Mono-to-Stereo function
- LFE by SRS TruBass /TruBass-II
- SRS Focus and Dialog Clarity
- SRS Definition
- The sampling rate is fixed with 48KHz.
- Master Volume
- WatchDog Clock Output

- Hardware

- 24bit Fixed-point Digital Signal Processing
- Maximum System Clock Frequency : 38MHz Max.
- Digital Audio Interface : 2 Input ports / 3 Output ports
- Digital Audio Format : I²S 24bit, Left- justified, Right-justified, Output bit is fixed 16bits. BCK:32/64fs
- Master / Slave Mode : Master Mode MCK 1/2 fclk, 1/3 fclk
ex. MCK = 384Fs(1/2) or MCK = 256Fs(1/3) at fclk=768Fs
- Power Supply : 2.5V
- Input terminal : 3.3V Input tolerant
- Package : QFP32-R1 (Pb-Free)
- Host interface : I²C bus (standard-mode/100kbps)

The detail hardware specification is described in the "NJU26150 Series Hardware Data Sheet".

NJU26150-19A

Function Block Diagram

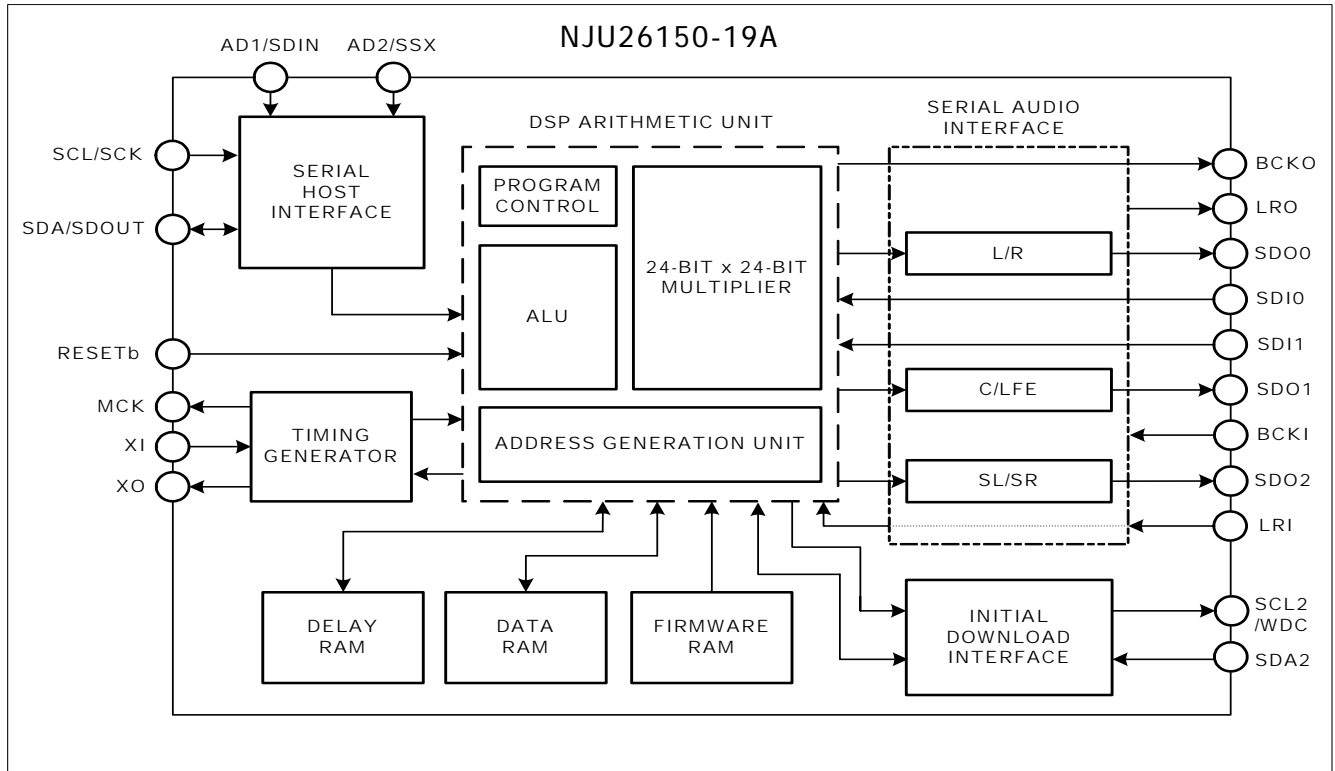

Fig. 1 NJU26150-19A Block Diagram

DSP Block Diagram

NJU26150-19A Top Level Block Diagram

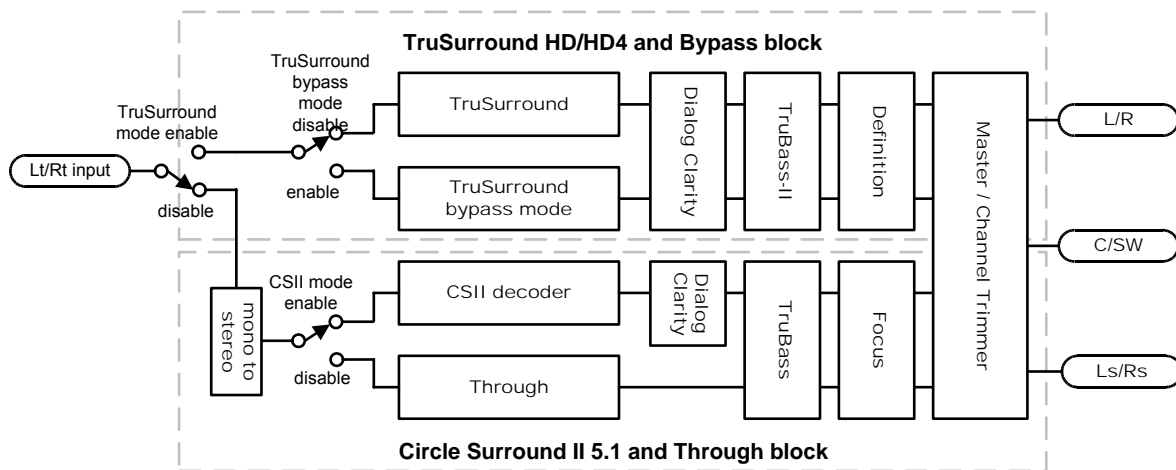

Fig. 2 NJU26150-19A Top Level Function Diagram

TruSurround HD/HD4 and Bypass mode Block Diagram

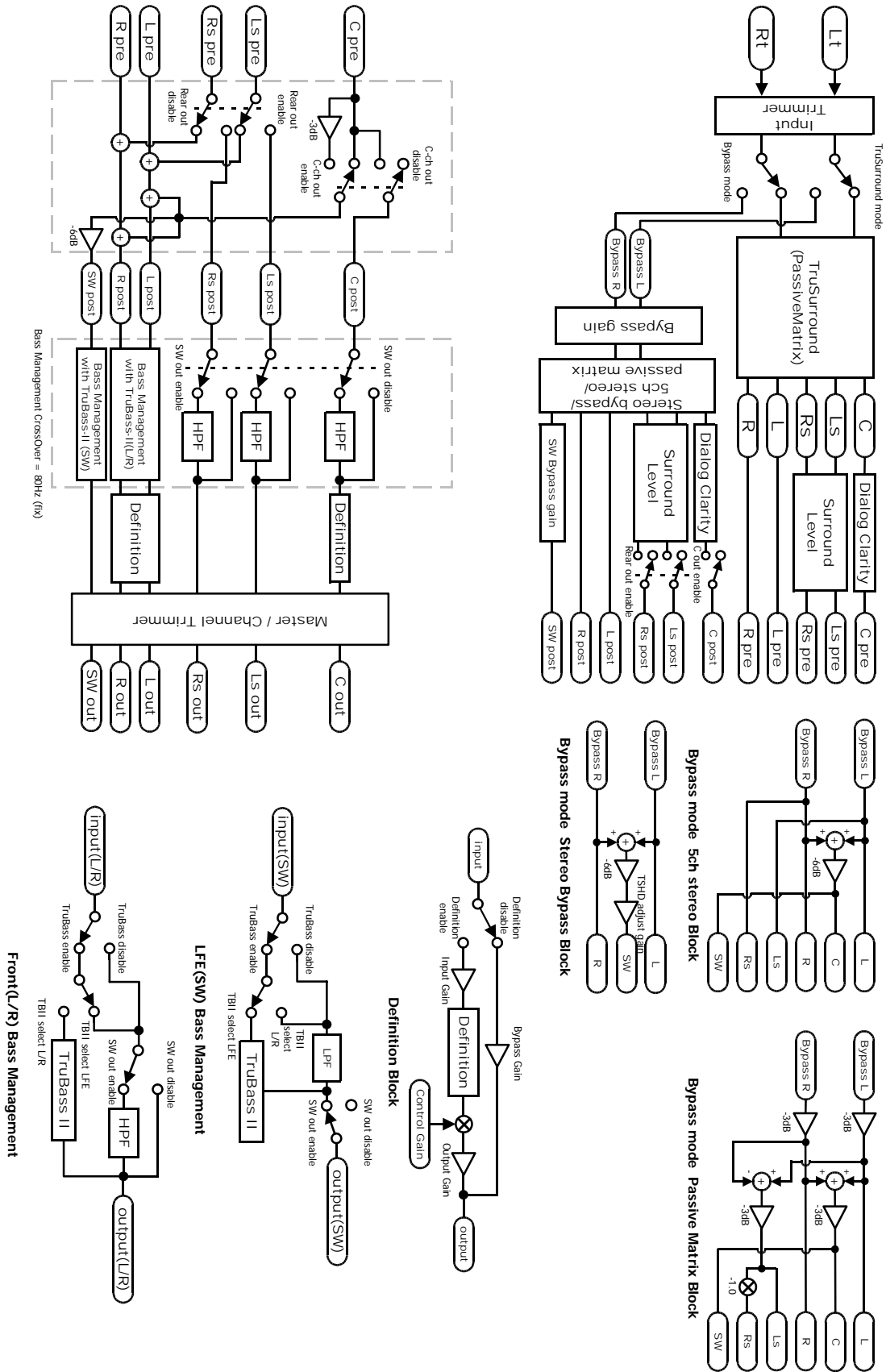

Fig. 3 NJU26150-19A (TruSurround HD/HD4 Mode) Function Diagram

Circle Surround II 5.1 mode / Through Mode

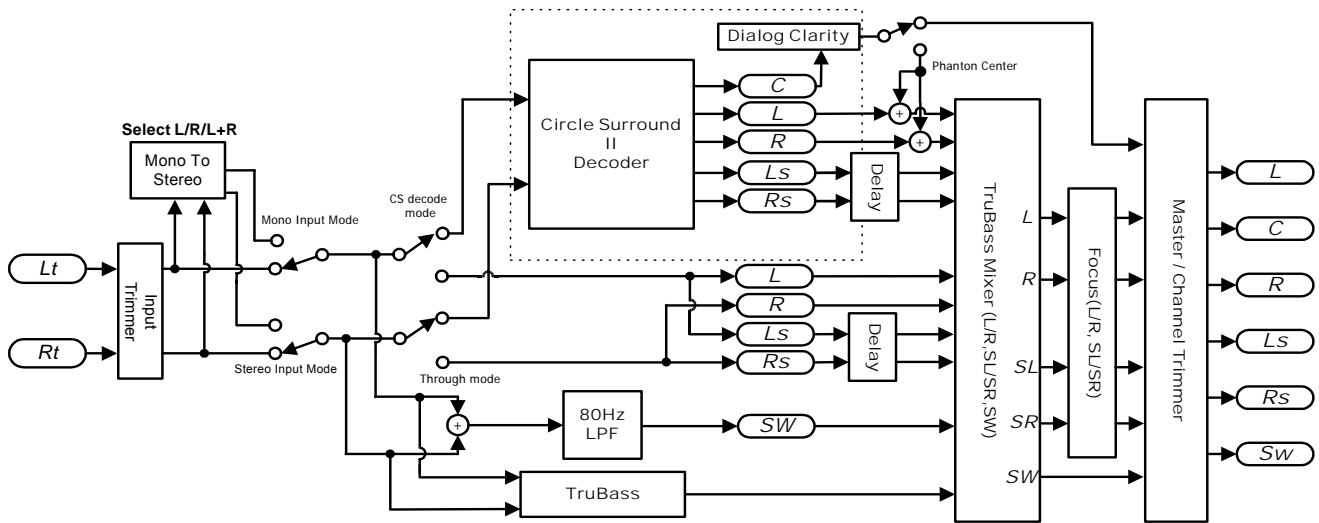

Fig. 4 NJU26150-19A (CSII5.1/Through Mode) Function Diagram

Pin Configuration

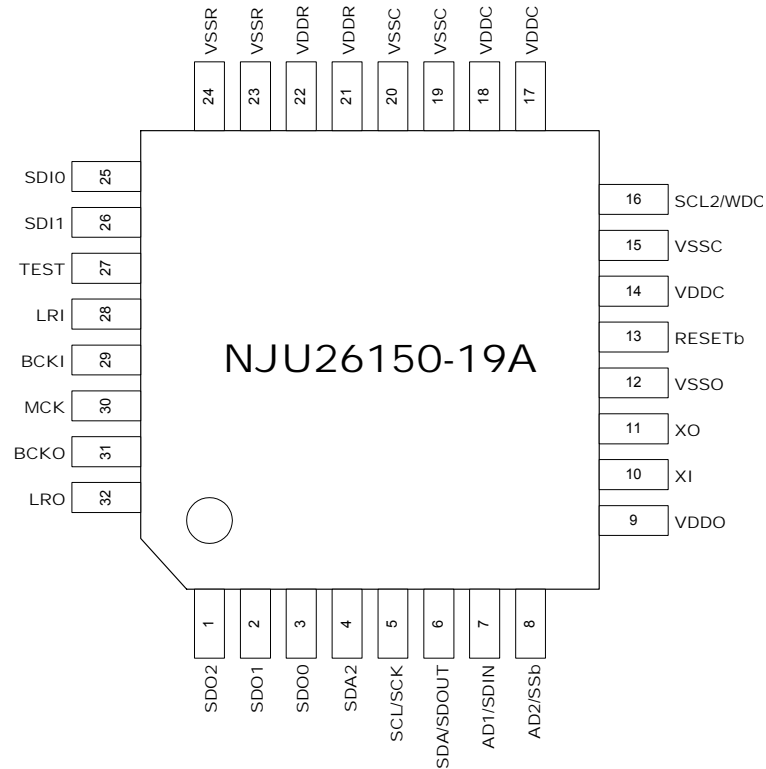

Fig. 5 NJU26150-19A Pin Configuration

Pin Description

Table 1 Pin Description

No.	Symbol	I/O	Description
1	SDO2	O	Audio Data Output 2
2	SDO1	O	Audio Data Output 1
3	SDO0	O	Audio Data Output 0
4	SDA2	I/O	Select I ² C (For program down load) This pin requires a pull-up resistance.
5	SCL	I	I ² C Clock
6	SDA	I/O	I ² C I/O This pin requires a pull-up resistance.
7	AD1	I	I ² C Address / Serial Input
8	AD2	I	I ² C Address / Serial Enable
9	VDDO	--	OSC Power Supply +2.5V
10	XI	I	X'tal Clock Input
11	XO	O	OSC Output
12	VSSO	--	OSC GND
13	RESETb	I	RESET (active Low)
14	VDDC	--	Core Power Supply +2.5V
15	VSSC	--	Core GND
16	SCL2/WDC	O	I ² C Clock(For program down load) /Clock for Watch Dog Timer

No.	Symbol	I/O	Description
17	VDDC	--	Core Power Supply +2.5V
18	VSSC	--	Core GND
19	VSSC	--	Core GND
20	VSSC	--	Core GND
21	VDDR	--	I/O Power Supply +2.5V
22	VDDR	--	I/O Power Supply +2.5V
23	VSSR	--	I/O GND
24	VSSR	--	I/O GND
25	SDI0	I	Audio Data Input 0
26	SDI1	I	Audio Data Input 1
27	TEST	I	Connect to GND
28	LRI	I	LR Clock Input
29	BCKI	I	Bit Clock Input
30	MCK	O	Master Clock Output
31	BCKO	O	Bit Clock Output
32	LRO	O	LR Clock Output

* I : Input,
O : Output,
I/O: Bi-directional

■ Digital Audio Interface

The NJU26150-19A audio interface provides industry standard serial data formats of I²S, MSB-first left-justified or MSB-first right-justified. The NJU26150-19A audio interface provides two data inputs, SDI0, SDI1 and three data outputs, SDO0, SDO1, SDO1, as shown in table 2, table 3 and Fig.3, Fig.4. An audio interface input and output data format become the same data format.

Table 2 Serial Audio Input Pin

Pin No.	Symbol	Description
25	SDI0	Audio Data Input 0
26	SDI1	Audio Data Input 1

Table 3 Serial Audio Output Pin

Pin No.	Symbol	Description
3	SDO0	Audio Data Output 0 L / R
2	SDO1	Audio Data Output 1 C /SW
1	SDO2	Audio Data Output 2 Ls/Rs

■ Host Interface

The NJU26150-19A can be controlled via Serial Host Interface (SHI) using I²C bus. Data transfers are in 8 bit packets (1 byte) when using either format. Serial Host Interface Pin Description.(Table 4)

Table 4 Serial Host Interface Pin Description

Pin No.	Symbol	I ² C bus Format
5	SCL	Serial Clock
6	SDA	Serial Data Input/Output (Open Drain Input/Output)
7	AD1	I ² C bus address Bit1
8	AD2	I ² C bus address Bit2

Note : SDA pin is a bi-directional open drain. This pin requires a pull-up resistor.

■ I²C bus

When the NJU26150-19A is configured for I²C bus communication during the Reset initialization sequence. I²C bus interface transfers data to the SDA pin and clocks data to the SCL pin.

AD1 and AD2 pins are used to configure the seven-bit SLAVE address of the serial host interface. (Table 5) This offers additional flexibility to a system design by four different SLAVE addresses of the NJU26150-19A. An address can be arbitrarily set up by the AD1 and AD2 pins. The I²C address of AD1/AD2 is decided by connection of AD1/AD2 pins.

Table 5 I²C bus SLAVE Address

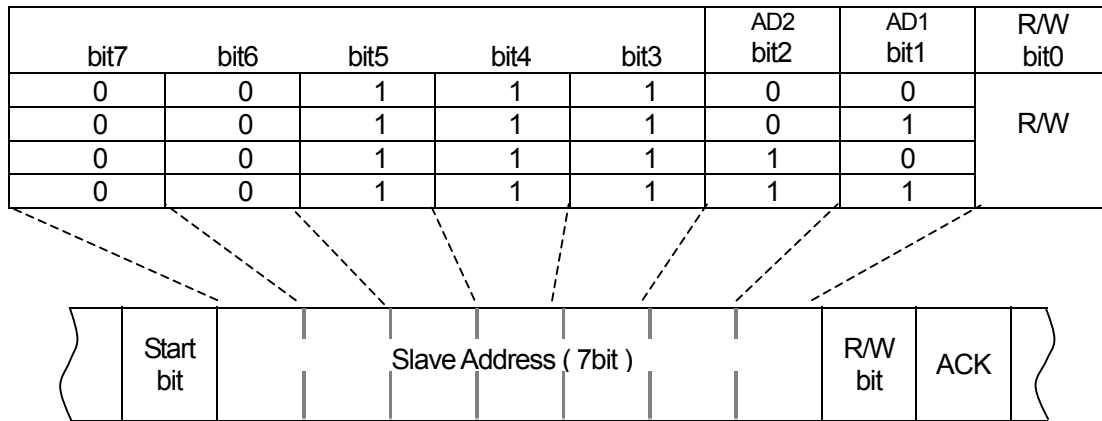

* SLAVE address is 0 when AD1/2 is “Low”. SLAVE address is 1 when AD1/2 is “High”.

Note : In case of the NJU26150-19A, only single-byte transmission is available. The serial host interface supports “Standard-Mode (100kbps)” I²C bus data transfer.

■ WatchDog Clock

The NJU26150-19A outputs clock pulse through WDC (No.16) pin during normal operation. The output toggle cycle (Low/High) from a WDC pin changes with sampling frequencies. (Table 6)

Table 6 WatchDog Clock Output Cycle

Sampling Frequencies	WDC Output Cycle (Low/High) Time
48 KHz	85ms

The NJU26150-19A generates a clock pulse through the WDC terminal after resetting the NJU26150-19A. The WDC clock is useful to check the status of the NJU26150-19A operation. For example, a microcomputer monitors the WDC clock and checks the status of the NJU26150-19A. When the WDC clock pulse is lost or not normal clock cycle, the NJU26150-19A does not operate correctly. Then reset the NJU26150-19A and set up the NJU26150-19A again.

Note: If input and output of a audio signal stop and an audio interface stops, WDC can't output. That is because it has controlled based on the signal of an audio interface.

NJU26150-19A

www.DataSheet4U.com

■ NJU26150-19A Command Table

Table 7 NJU26150-19A Command

No.	Command	No.	Command
1	SET_TASK_CMD	20	SYS_SET_CMD
2	CS_MOD_CMD	21	TB_CTRL_CMD2
3	TB_MOD_CMD	22	TB_CTRL_CMD3
4	TB_CTRL_CMD1	23	FC_CTRL_CMD2
5	FC_MOD_CMD	24	FC_CTRL_CMD3
6	FC_CTRL_CMD1	25	TSHD_CONFIG_CMD
7	MONO_SEL_CMD	26	DF_SELECT_CMD
8	FS_CMD	27	TBII_MODE_CMD
9	REAR_BOOST_CMD	28	TSHD_BYPASS_GAIN_CMD
10	4STREO_CMD	29	TSHD_SRND_LEVEL_CMD
11	DLY_CMD	30	DF_FRONT_BYPASS_CMD
12	MST_VOL_CMD	31	DF_FRONT_INPUT_CMD
13	INPUT_VOL_CMD	32	DF_FRONT_CNTRL_CMD
14	LCH_VOL_CMD	33	DF_FRONT_OUTPUT_CMD
15	RCH_VOL_CMD	34	DF_CENTER_BYPASS_CMD
16	CENT_VOL_CMD	35	DF_CENTER_INPUT_CMD
17	SURR_LEFT_VOL_CMD	36	DF_CENTER_CNTRL_CMD
18	SURR_RIGHT_VOL_CMD	37	DF_CENTER_OUTPUT_CMD
19	SW_VOL_CMD	38	TSHD_BYPASS_SW_CMD

Notes : In respect to detail command information, request New Japan Radio Co., Ltd. and permission of a licenser (SRS Labs. Inc.) is required.

■ License Information

1. The “SRS Circle SurroundII5.1”, “TruSurround HD”, “TruSurround HD4”, “TruBass”, ”FOCUS”, “Dialog Clarity” technology rights incorporated in the NJU26150-19A are owned by SRS Labs, a U.S. Corporation and licensed to New Japan Radio Co., Ltd.. Purchaser of NJU26150-19A must sign a license for use of the chip and display of the Labs trademarks. Any products incorporathing the NJU26150-19A must be send to SRS Labs for review. “SRS Circle SurroundII5.1”, “TruSurround HD”, “TruSurround HD4”, “TruBass”, ”FOCUS”, “Dialog Clarity” are protected under US and foreign patents issued and/or pending. “SRS Circle SurroundII5.1”, “TruSurround HD”, “TruSurround HD4”, “TruBass”, ”FOCUS”, “Dialog Clarity”, SRS and  symbol are trademarks of SRS Labs, Inc. in the United States and selected foreign countries. Neither the purchase of the NJU26150-19A, nor the corresponding sale of audio enhancement equipment conveys the right to sell commercialized recordings made with any SRS technology. SRS Labs requires all set marks to comply with all rules and regulations as outlined in the SRS Trademark Usage Manual separately provided.

For further information, please contact::

SRS Labs, Inc.
2909 Daimler Street.
Santa Ana, CA 92705 USA
Tel: 949-442-1070 Fax: 949-852-1099 <http://www.srslabs.com>

[CAUTION]

The specifications on this databook are only given for information , without any guarantee as regards either mistakes or omissions. The application circuits in this databook are described only to show representative usages of the product and not intended for the guarantee or permission of any right including the industrial rights.