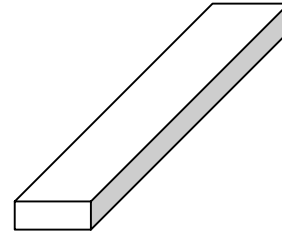

STATIC 1/3 1/4 1/8 1/9 Segment type LCD Driver

■ GENERAL DESCRIPTION

The NJU6549 is a STATIC or 1/3, 1/4, 1/8, 1/9 duty segment type LCD driver. It incorporates 9 common driver circuits and 200 segment driver circuits. The NJU6549 can drive maximum 1800 segments in 1/9 duty ratio(1/4 Bias). In addition, the NJU6549's useful functions meet a wide range of applications.

NJU6549

■ FEATURES

LCD driving circuit	: Max.1800outputs
Duty Ratio	:Static :Driving max 200 segments :1/3Duty Ratio (1/3Bias): Driving max 600 segments :1/4Duty Ratio (1/3Bias): Driving max.800 segments :1/8Duty Ratio (1/4Bias): Driving max.1600 segments :1/9Duty Ratio (1/4Bias): Driving max.1800 segments
Serial Data Transfer	: Shift clock max. 2MHz
Oscillator	: CR oscillation with external resistor and capacitor, or external oscillation signal input.
Operating wave form	: A wave form or B wave form
Voltage doublers and bleeder resistance	on-chip.
Display Off	: INHb Terminal
DUTY, BIAS select	: T1, T2, TEST3 Terminals
Operating Voltage	: 4.0~5.5V
C-MOS Technology	: P-Sub
Package outline	: Bump Chip

■ BLOCK DIAGRAM

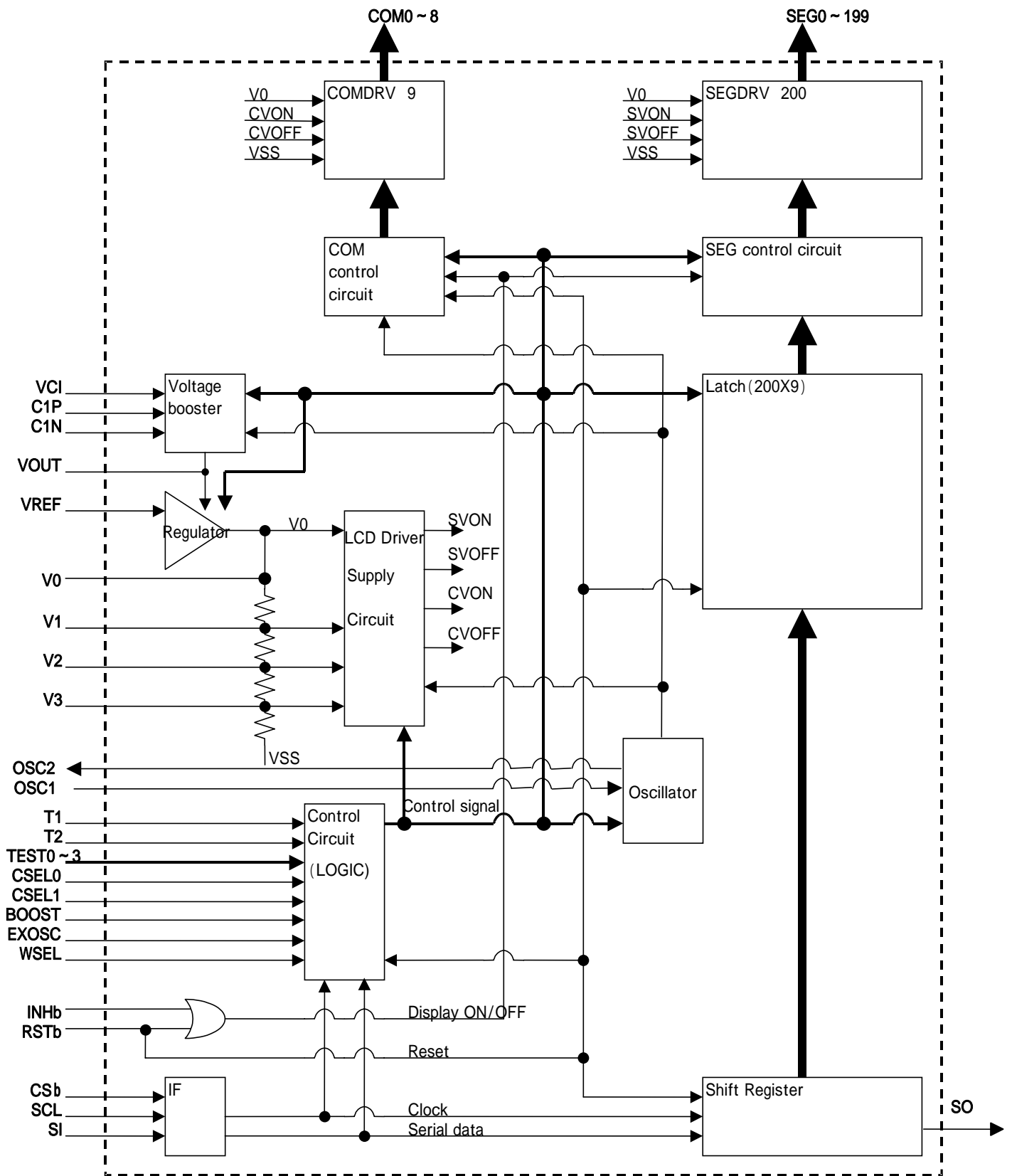

■ PAD LOCATION

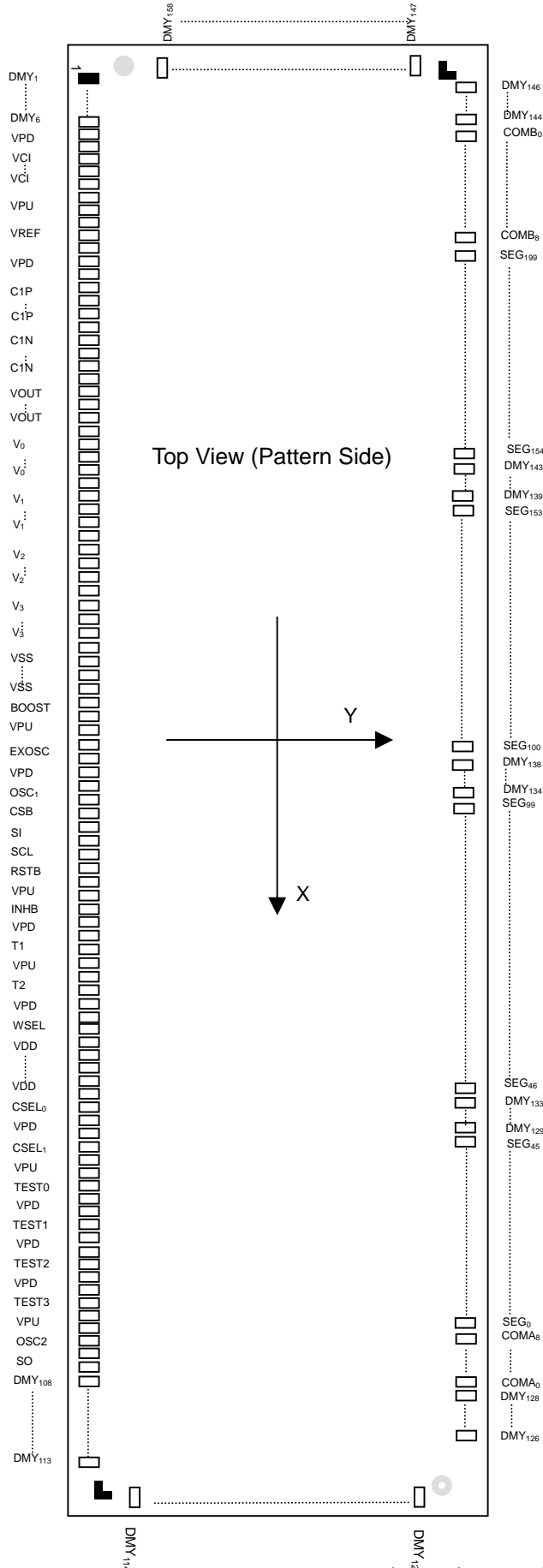

Alignment mark1
Coordinates
(-6650,-535)

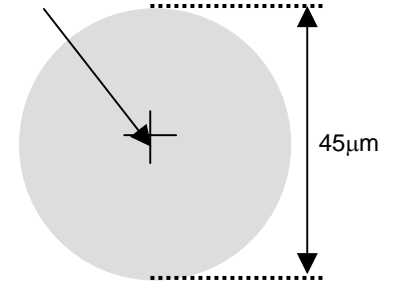

Alignment mark2
Coordinates
(6650,535)

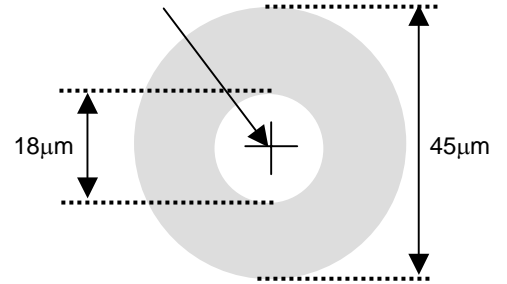

Alignment mark3
Coordinates
(6650,-535)
(-6650,535)

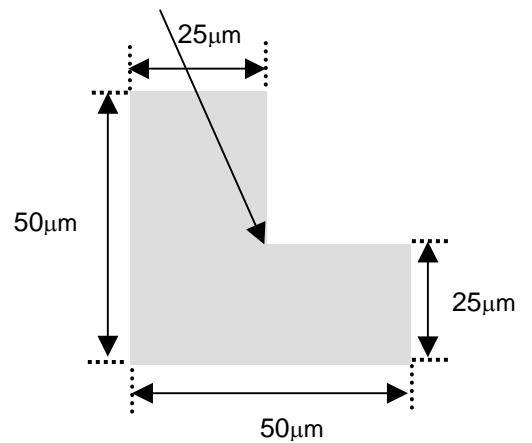

Chip Center	:X=0μm, Y=0μm
Chip Size	:X=13.60mm, Y= 1.37mm
Chip Thickness	:625μm ± 30μm
Bump Pitch	:55.0μm
Bump Size	:32.0μm x 106.0μm
Bump Height	:17.5μm(Typ)
Bump Material	:Au

Note) Dummy PAD between the input terminals is skipped .

■ PAD COORDINATES 1

Chip Size 13.60mm x 1.37mm(Chip Center 0.00μm x 0.00μm)

PAD No.	Terminal	X=μm	Y=μm
1	DUMMY1	-6545.00	-538.00
2	DUMMY2	-6490.00	-538.00
3	DUMMY3	-6435.00	-538.00
4	DUMMY4	-6380.00	-538.00
5	DUMMY5	-6325.00	-538.00
6	DUMMY6	-6270.00	-538.00
7	VPD	-6215.00	-538.00
8	VPD	-6160.00	-538.00
9	DUMMY7	-6105.00	-538.00
10	DUMMY8	-6050.00	-538.00
11	VCI	-5995.00	-538.00
12	VCI	-5940.00	-538.00
13	VCI	-5885.00	-538.00
14	VCI	-5830.00	-538.00
15	VCI	-5775.00	-538.00
16	VCI	-5720.00	-538.00
17	VCI	-5665.00	-538.00
18	VCI	-5610.00	-538.00
19	DUMMY9	-5555.00	-538.00
20	DUMMY10	-5500.00	-538.00
21	VPU	-5445.00	-538.00
22	VPU	-5390.00	-538.00
23	DUMMY11	-5335.00	-538.00
24	DUMMY12	-5280.00	-538.00
25	VREF	-5225.00	-538.00
26	DUMMY13	-5170.00	-538.00
27	DUMMY14	-5115.00	-538.00
28	VPD	-5060.00	-538.00
29	VPD	-5005.00	-538.00
30	DUMMY15	-4950.00	-538.00
31	DUMMY16	-4895.00	-538.00
32	DUMMY17	-4840.00	-538.00
33	C1P	-4785.00	-538.00
34	C1P	-4730.00	-538.00
35	C1P	-4675.00	-538.00
36	C1P	-4620.00	-538.00
37	C1P	-4565.00	-538.00
38	C1P	-4510.00	-538.00
39	DUMMY18	-4455.00	-538.00
40	DUMMY19	-4400.00	-538.00
41	DUMMY20	-4345.00	-538.00
42	C1N	-4290.00	-538.00
43	C1N	-4235.00	-538.00
44	C1N	-4180.00	-538.00
45	C1N	-4125.00	-538.00
46	C1N	-4070.00	-538.00
47	C1N	-4015.00	-538.00
48	DUMMY21	-3960.00	-538.00
49	DUMMY22	-3905.00	-538.00
50	DUMMY23	-3850.00	-538.00

PAD No.	Terminal	X=μm	Y=μm
51	VOUT	-3795.00	-538.00
52	VOUT	-3740.00	-538.00
53	VOUT	-3685.00	-538.00
54	VOUT	-3630.00	-538.00
55	VOUT	-3575.00	-538.00
56	VOUT	-3520.00	-538.00
57	VOUT	-3465.00	-538.00
58	VOUT	-3410.00	-538.00
59	DUMMY24	-3355.00	-538.00
60	DUMMY25	-3300.00	-538.00
61	DUMMY26	-3245.00	-538.00
62	V0	-3190.00	-538.00
63	V0	-3135.00	-538.00
64	V0	-3080.00	-538.00
65	V0	-3025.00	-538.00
66	V0	-2970.00	-538.00
67	V0	-2915.00	-538.00
68	V0	-2860.00	-538.00
69	V0	-2805.00	-538.00
70	DUMMY27	-2750.00	-538.00
71	DUMMY28	-2695.00	-538.00
72	DUMMY29	-2640.00	-538.00
73	V1	-2585.00	-538.00
74	V1	-2530.00	-538.00
75	V1	-2475.00	-538.00
76	V1	-2420.00	-538.00
77	V1	-2365.00	-538.00
78	V1	-2310.00	-538.00
79	V1	-2255.00	-538.00
80	V1	-2200.00	-538.00
81	DUMMY30	-2145.00	-538.00
82	DUMMY31	-2090.00	-538.00
83	DUMMY32	-2035.00	-538.00
84	V2	-1980.00	-538.00
85	V2	-1925.00	-538.00
86	V2	-1870.00	-538.00
87	V2	-1815.00	-538.00
88	V2	-1760.00	-538.00
89	V2	-1705.00	-538.00
90	V2	-1650.00	-538.00
91	V2	-1595.00	-538.00
92	DUMMY33	-1540.00	-538.00
93	DUMMY34	-1485.00	-538.00
94	DUMMY35	-1430.00	-538.00
95	V3	-1375.00	-538.00
96	V3	-1320.00	-538.00
97	V3	-1265.00	-538.00
98	V3	-1210.00	-538.00
99	V3	-1155.00	-538.00
100	V3	-1100.00	-538.00

■ PAD COORDINATES 2

PAD No.	Terminal	X=μm	Y=μm
101	V3	-1045.00	-538.00
102	V3	-990.00	-538.00
103	DUMMY36	-935.00	-538.00
104	DUMMY37	-880.00	-538.00
105	DUMMY38	-825.00	-538.00
106	DUMMY39	-770.00	-538.00
107	DUMMY40	-715.00	-538.00
108	VSS	-660.00	-538.00
109	VSS	-605.00	-538.00
110	VSS	-550.00	-538.00
111	VSS	-495.00	-538.00
112	VSS	-440.00	-538.00
113	VSS	-385.00	-538.00
114	VSS	-330.00	-538.00
115	VSS	-275.00	-538.00
116	DUMMY41	-220.00	-538.00
117	DUMMY42	-165.00	-538.00
118	DUMMY43	-110.00	-538.00
119	DUMMY44	-55.00	-538.00
120	DUMMY45	0.00	-538.00
121	BOOST	55.00	-538.00
122	DUMMY46	110.00	-538.00
123	DUMMY47	165.00	-538.00
124	VPU	220.00	-538.00
125	VPU	275.00	-538.00
126	DUMMY48	330.00	-538.00
127	DUMMY49	385.00	-538.00
128	EXOSC	440.00	-538.00
129	DUMMY50	495.00	-538.00
130	DUMMY51	550.00	-538.00
131	VPD	605.00	-538.00
132	VPD	660.00	-538.00
133	DUMMY52	715.00	-538.00
134	DUMMY53	770.00	-538.00
135	OSC1	825.00	-538.00
136	DUMMY54	880.00	-538.00
137	DUMMY55	935.00	-538.00
138	CSB	990.00	-538.00
139	DUMMY56	1045.00	-538.00
140	DUMMY57	1100.00	-538.00
141	SI	1155.00	-538.00
142	DUMMY58	1210.00	-538.00
143	DUMMY59	1265.00	-538.00
144	SCL	1320.00	-538.00
145	DUMMY60	1375.00	-538.00
146	DUMMY61	1430.00	-538.00
147	RSTB	1485.00	-538.00
148	DUMMY62	1540.00	-538.00
149	DUMMY63	1595.00	-538.00
150	VPU	1650.00	-538.00

PAD No.	Terminal	Xμ=m	Y=μm
151	VPU	1705.00	-538.00
152	DUMMY64	1760.00	-538.00
153	DUMMY65	1815.00	-538.00
154	INHB	1870.00	-538.00
155	DUMMY66	1925.00	-538.00
156	DUMMY67	1980.00	-538.00
157	VPD	2035.00	-538.00
158	VPD	2090.00	-538.00
159	DUMMY68	2145.00	-538.00
160	DUMMY69	2200.00	-538.00
161	T1	2255.00	-538.00
162	DUMMY70	2310.00	-538.00
163	DUMMY71	2365.00	-538.00
164	VPU	2420.00	-538.00
165	VPU	2475.00	-538.00
166	DUMMY72	2530.00	-538.00
167	DUMMY73	2585.00	-538.00
168	T2	2640.00	-538.00
169	DUMMY74	2695.00	-538.00
170	DUMMY75	2750.00	-538.00
171	VPD	2805.00	-538.00
172	VPD	2860.00	-538.00
173	DUMMY76	2915.00	-538.00
174	DUMMY77	2970.00	-538.00
175	WSEL	3025.00	-538.00
176	DUMMY78	3080.00	-538.00
177	DUMMY79	3135.00	-538.00
178	VDD	3190.00	-538.00
179	VDD	3245.00	-538.00
180	VDD	3300.00	-538.00
181	VDD	3355.00	-538.00
182	VDD	3410.00	-538.00
183	VDD	3465.00	-538.00
184	VDD	3520.00	-538.00
185	VDD	3575.00	-538.00
186	DUMMY80	3630.00	-538.00
187	DUMMY81	3685.00	-538.00
188	CSEL0	3740.00	-538.00
189	DUMMY82	3795.00	-538.00
190	DUMMY83	3850.00	-538.00
191	VPD	3905.00	-538.00
192	VPD	3960.00	-538.00
193	DUMMY84	4015.00	-538.00
194	DUMMY85	4070.00	-538.00
195	CSEL1	4125.00	-538.00
196	DUMMY86	4180.00	-538.00
197	DUMMY87	4235.00	-538.00
198	VPU	4290.00	-538.00
199	VPU	4345.00	-538.00
200	DUMMY88	4400.00	-538.00

■ PAD COORDINATES 3

PAD No.	Terminal	X= μ m	Y= μ m
201	DUMMY89	4455.00	-538.00
202	TEST0	4510.00	-538.00
203	DUMMY90	4565.00	-538.00
204	DUMMY91	4620.00	-538.00
205	VPD	4675.00	-538.00
206	VPD	4730.00	-538.00
207	DUMMY92	4785.00	-538.00
208	DUMMY93	4840.00	-538.00
209	TEST1	4895.00	-538.00
210	DUMMY94	4950.00	-538.00
211	DUMMY95	5005.00	-538.00
212	VPD	5060.00	-538.00
213	VPD	5115.00	-538.00
214	DUMMY96	5170.00	-538.00
215	DUMMY97	5225.00	-538.00
216	TEST2	5280.00	-538.00
217	DUMMY98	5335.00	-538.00
218	DUMMY99	5390.00	-538.00
219	VPD	5445.00	-538.00
220	VPD	5500.00	-538.00
221	DUMMY100	5555.00	-538.00
222	DUMMY101	5610.00	-538.00
223	TEST3	5665.00	-538.00
224	DUMMY102	5720.00	-538.00
225	DUMMY103	5775.00	-538.00
226	VPU	5830.00	-538.00
227	VPU	5885.00	-538.00
228	DUMMY104	5940.00	-538.00
229	DUMMY105	5995.00	-538.00
230	OSC2	6050.00	-538.00
231	DUMMY106	6105.00	-538.00
232	DUMMY107	6160.00	-538.00
233	SO	6215.00	-538.00
234	DUMMY108	6270.00	-538.00
235	DUMMY109	6325.00	-538.00
236	DUMMY110	6380.00	-538.00
237	DUMMY111	6435.00	-538.00
238	DUMMY112	6490.00	-538.00
239	DUMMY113	6545.00	-538.00
240	DUMMY114	6653.00	-302.50
241	DUMMY115	6653.00	-247.50
242	DUMMY116	6653.00	-192.50
243	DUMMY117	6653.00	-137.50
244	DUMMY118	6653.00	-82.50
245	DUMMY119	6653.00	-27.50
246	DUMMY120	6653.00	27.50
247	DUMMY121	6653.00	82.50
248	DUMMY122	6653.00	137.50
249	DUMMY123	6653.00	192.50
250	DUMMY124	6653.00	247.50

PAD No.	Terminal	X= μ m	Y= μ m
251	DUMMY125	6653.00	302.50
252	DUMMY126	6545.00	538.00
253	DUMMY127	6490.00	538.00
254	DUMMY128	6435.00	538.00
255	COMA0	6380.00	538.00
256	COMA1	6325.00	538.00
257	COMA2	6270.00	538.00
258	COMA3	6215.00	538.00
259	COMA4	6160.00	538.00
260	COMA5	6105.00	538.00
261	COMA6	6050.00	538.00
262	COMA7	5995.00	538.00
263	COMA8	5940.00	538.00
264	SEG0	5885.00	538.00
265	SEG1	5830.00	538.00
266	SEG2	5775.00	538.00
267	SEG3	5720.00	538.00
268	SEG4	5665.00	538.00
269	SEG5	5610.00	538.00
270	SEG6	5555.00	538.00
271	SEG7	5500.00	538.00
272	SEG8	5445.00	538.00
273	SEG9	5390.00	538.00
274	SEG10	5335.00	538.00
275	SEG11	5280.00	538.00
276	SEG12	5225.00	538.00
277	SEG13	5170.00	538.00
278	SEG14	5115.00	538.00
279	SEG15	5060.00	538.00
280	SEG16	5005.00	538.00
281	SEG17	4950.00	538.00
282	SEG18	4895.00	538.00
283	SEG19	4840.00	538.00
284	SEG20	4785.00	538.00
285	SEG21	4730.00	538.00
286	SEG22	4675.00	538.00
287	SEG23	4620.00	538.00
288	SEG24	4565.00	538.00
289	SEG25	4510.00	538.00
290	SEG26	4455.00	538.00
291	SEG27	4400.00	538.00
292	SEG28	4345.00	538.00
293	SEG29	4290.00	538.00
294	SEG30	4235.00	538.00
295	SEG31	4180.00	538.00
296	SEG32	4125.00	538.00
297	SEG33	4070.00	538.00
298	SEG34	4015.00	538.00
299	SEG35	3960.00	538.00
300	SEG36	3905.00	538.00

■ PAD COORDINATES 4

PAD No.	Terminal	X= μ m	Y= μ m
301	SEG37	3850.00	538.00
302	SEG38	3795.00	538.00
303	SEG39	3740.00	538.00
304	SEG40	3685.00	538.00
305	SEG41	3630.00	538.00
306	SEG42	3575.00	538.00
307	SEG43	3520.00	538.00
308	SEG44	3465.00	538.00
309	SEG45	3410.00	538.00
310	DUMMY129	3355.00	538.00
311	DUMMY130	3300.00	538.00
312	DUMMY131	3245.00	538.00
313	DUMMY132	3190.00	538.00
314	DUMMY133	3135.00	538.00
315	SEG46	3080.00	538.00
316	SEG47	3025.00	538.00
317	SEG48	2970.00	538.00
318	SEG49	2915.00	538.00
319	SEG50	2860.00	538.00
320	SEG51	2805.00	538.00
321	SEG52	2750.00	538.00
322	SEG53	2695.00	538.00
323	SEG54	2640.00	538.00
324	SEG55	2585.00	538.00
325	SEG56	2530.00	538.00
326	SEG57	2475.00	538.00
327	SEG58	2420.00	538.00
328	SEG59	2365.00	538.00
329	SEG60	2310.00	538.00
330	SEG61	2255.00	538.00
331	SEG62	2200.00	538.00
332	SEG63	2145.00	538.00
333	SEG64	2090.00	538.00
334	SEG65	2035.00	538.00
335	SEG66	1980.00	538.00
336	SEG67	1925.00	538.00
337	SEG68	1870.00	538.00
338	SEG69	1815.00	538.00
339	SEG70	1760.00	538.00
340	SEG71	1705.00	538.00
341	SEG72	1650.00	538.00
342	SEG73	1595.00	538.00
343	SEG74	1540.00	538.00
344	SEG75	1485.00	538.00
345	SEG76	1430.00	538.00
346	SEG77	1375.00	538.00
347	SEG78	1320.00	538.00
348	SEG79	1265.00	538.00
349	SEG80	1210.00	538.00
350	SEG81	1155.00	538.00

PAD No.	Terminal	X= μ m	Y= μ m
351	SEG82	1100.00	538.00
352	SEG83	1045.00	538.00
353	SEG84	990.00	538.00
354	SEG85	935.00	538.00
355	SEG86	880.00	538.00
356	SEG87	825.00	538.00
357	SEG88	770.00	538.00
358	SEG89	715.00	538.00
359	SEG90	660.00	538.00
360	SEG91	605.00	538.00
361	SEG92	550.00	538.00
362	SEG93	495.00	538.00
363	SEG94	440.00	538.00
364	SEG95	385.00	538.00
365	SEG96	330.00	538.00
366	SEG97	275.00	538.00
367	SEG98	220.00	538.00
368	SEG99	165.00	538.00
369	DUMMY134	110.00	538.00
370	DUMMY135	55.00	538.00
371	DUMMY136	0.00	538.00
372	DUMMY137	-55.00	538.00
373	DUMMY138	-110.00	538.00
374	SEG100	-165.00	538.00
375	SEG101	-220.00	538.00
376	SEG102	-275.00	538.00
377	SEG103	-330.00	538.00
378	SEG104	-385.00	538.00
379	SEG105	-440.00	538.00
380	SEG106	-495.00	538.00
381	SEG107	-550.00	538.00
382	SEG108	-605.00	538.00
383	SEG109	-660.00	538.00
384	SEG110	-715.00	538.00
385	SEG111	-770.00	538.00
386	SEG112	-825.00	538.00
387	SEG113	-880.00	538.00
388	SEG114	-935.00	538.00
389	SEG115	-990.00	538.00
390	SEG116	-1045.00	538.00
391	SEG117	-1100.00	538.00
392	SEG118	-1155.00	538.00
393	SEG119	-1210.00	538.00
394	SEG120	-1265.00	538.00
395	SEG121	-1320.00	538.00
396	SEG122	-1375.00	538.00
397	SEG123	-1430.00	538.00
398	SEG124	-1485.00	538.00
399	SEG125	-1540.00	538.00
400	SEG126	-1595.00	538.00

■ PAD COORDINATES 5

PAD No.	Terminal	X= μ m	Y= μ m
401	SEG127	-1650.00	538.00
402	SEG128	-1705.00	538.00
403	SEG129	-1760.00	538.00
404	SEG130	-1815.00	538.00
405	SEG131	-1870.00	538.00
406	SEG132	-1925.00	538.00
407	SEG133	-1980.00	538.00
408	SEG134	-2035.00	538.00
409	SEG135	-2090.00	538.00
410	SEG136	-2145.00	538.00
411	SEG137	-2200.00	538.00
412	SEG138	-2255.00	538.00
413	SEG139	-2310.00	538.00
414	SEG140	-2365.00	538.00
415	SEG141	-2420.00	538.00
416	SEG142	-2475.00	538.00
417	SEG143	-2530.00	538.00
418	SEG144	-2585.00	538.00
419	SEG145	-2640.00	538.00
420	SEG146	-2695.00	538.00
421	SEG147	-2750.00	538.00
422	SEG148	-2805.00	538.00
423	SEG149	-2860.00	538.00
424	SEG150	-2915.00	538.00
425	SEG151	-2970.00	538.00
426	SEG152	-3025.00	538.00
427	SEG153	-3080.00	538.00
428	DUMMY139	-3135.00	538.00
429	DUMMY140	-3190.00	538.00
430	DUMMY141	-3245.00	538.00
431	DUMMY142	-3300.00	538.00
432	DUMMY143	-3355.00	538.00
433	SEG154	-3410.00	538.00
434	SEG155	-3465.00	538.00
435	SEG156	-3520.00	538.00
436	SEG157	-3575.00	538.00
437	SEG158	-3630.00	538.00
438	SEG159	-3685.00	538.00
439	SEG160	-3740.00	538.00
440	SEG161	-3795.00	538.00
441	SEG162	-3850.00	538.00
442	SEG163	-3905.00	538.00
443	SEG164	-3960.00	538.00
444	SEG165	-4015.00	538.00
445	SEG166	-4070.00	538.00
446	SEG167	-4125.00	538.00
447	SEG168	-4180.00	538.00
448	SEG169	-4235.00	538.00
449	SEG170	-4290.00	538.00
450	SEG171	-4345.00	538.00

PAD No.	Terminal	X= μ m	Y= μ m
451	SEG172	-4400.00	538.00
452	SEG173	-4455.00	538.00
453	SEG174	-4510.00	538.00
454	SEG175	-4565.00	538.00
455	SEG176	-4620.00	538.00
456	SEG177	-4675.00	538.00
457	SEG178	-4730.00	538.00
458	SEG179	-4785.00	538.00
459	SEG180	-4840.00	538.00
460	SEG181	-4895.00	538.00
461	SEG182	-4950.00	538.00
462	SEG183	-5005.00	538.00
463	SEG184	-5060.00	538.00
464	SEG185	-5115.00	538.00
465	SEG186	-5170.00	538.00
466	SEG187	-5225.00	538.00
467	SEG188	-5280.00	538.00
468	SEG189	-5335.00	538.00
469	SEG190	-5390.00	538.00
470	SEG191	-5445.00	538.00
471	SEG192	-5500.00	538.00
472	SEG193	-5555.00	538.00
473	SEG194	-5610.00	538.00
474	SEG195	-5665.00	538.00
475	SEG196	-5720.00	538.00
476	SEG197	-5775.00	538.00
477	SEG198	-5830.00	538.00
478	SEG199	-5885.00	538.00
479	COMB8	-5940.00	538.00
480	COMB7	-5995.00	538.00
481	COMB6	-6050.00	538.00
482	COMB5	-6105.00	538.00
483	COMB4	-6160.00	538.00
484	COMB3	-6215.00	538.00
485	COMB2	-6270.00	538.00
486	COMB1	-6325.00	538.00
487	COMB0	-6380.00	538.00
488	DUMMY144	-6435.00	538.00
489	DUMMY145	-6490.00	538.00
490	DUMMY146	-6545.00	538.00
491	DUMMY147	-6653.00	302.50
492	DUMMY148	-6653.00	247.50
493	DUMMY149	-6653.00	192.50
494	DUMMY150	-6653.00	137.50
495	DUMMY151	-6653.00	82.50
496	DUMMY152	-6653.00	27.50
497	DUMMY153	-6653.00	-27.50
498	DUMMY154	-6653.00	-82.50
499	DUMMY155	-6653.00	-137.50
500	DUMMY156	-6653.00	-192.50
501	DUMMY157	-6653.00	-247.50
502	DUMMY158	-6653.00	-302.50

■ TERMINAL DISCRIPTION

No.	Pad Name	Function																				
178~185	V _{DD}	Power supply: 4.0-5.5V																				
21, 22, 124 125, 150, 151 164, 165, 198 199, 226, 227	VPU	It is connected with the terminal V _{DD} internally. When this terminal is not used, should be open. Note) Don't use main VDD.(Pull up only)																				
11~18	VCI	Booster voltage input terminal (Max:6V)																				
25	VREF	Regulator base voltage input terminal for V ₀ output (Max:VCI)																				
51~58	Vout	Booster voltage output terminal																				
62 ~ 69 73 ~ 80 84 ~ 91 95 ~ 102	V ₀ V ₁ V ₂ V ₃	LCD operating supply terminal V ₀ ≥ V ₁ ≥ V ₂ ≥ V ₃ ≥ V _{SS} , Note) When 1/3BIAS select (T1="L"), should be between V2 and V3 short																				
108~115	V _{SS}	GND V _{SS} =0V																				
7, 8, 28, 29 131, 132, 157 158, 171, 172 191, 192, 205 206, 212, 213 219, 220	VPD	It is connected with the terminal V _{SS} internally. When this terminal is not used, should be open. Note) Don't use main GND.(Pull down only)																				
154	INHb	Display ON or OFF "High"=Display ON, "Low"=Display OFF,																				
161 168	T1 T2	Duty and Bias select Terminal <table border="1"> <thead> <tr> <th>T1</th> <th>T2</th> <th>DUTY</th> <th>BIAS</th> </tr> </thead> <tbody> <tr> <td>L</td> <td>L</td> <td>1/3DUTY</td> <td>1/3BIAS</td> </tr> <tr> <td>L</td> <td>H</td> <td>1/4DUTY</td> <td>1/3BIAS</td> </tr> <tr> <td>H</td> <td>L</td> <td>1/8DUTY</td> <td>1/4BIAS</td> </tr> <tr> <td>H</td> <td>H</td> <td>1/9DUTY</td> <td>1/4BIAS</td> </tr> </tbody> </table>	T1	T2	DUTY	BIAS	L	L	1/3DUTY	1/3BIAS	L	H	1/4DUTY	1/3BIAS	H	L	1/8DUTY	1/4BIAS	H	H	1/9DUTY	1/4BIAS
T1	T2	DUTY	BIAS																			
L	L	1/3DUTY	1/3BIAS																			
L	H	1/4DUTY	1/3BIAS																			
H	L	1/8DUTY	1/4BIAS																			
H	H	1/9DUTY	1/4BIAS																			
121	BOOST	Voltage Converter ON or OFF "High"=Voltage Converter ON, "Low"=Voltage Converter OFF, <table border="1"> <thead> <tr> <th>BOOST</th> <th>Internal Converter circuit</th> <th>Internal regulator</th> <th>LCD operating voltage</th> </tr> </thead> <tbody> <tr> <td>H</td> <td>ON</td> <td>ON</td> <td>Internal converter circuit</td> </tr> <tr> <td>L</td> <td>OFF</td> <td>OFF</td> <td>External Input</td> </tr> </tbody> </table>	BOOST	Internal Converter circuit	Internal regulator	LCD operating voltage	H	ON	ON	Internal converter circuit	L	OFF	OFF	External Input								
BOOST	Internal Converter circuit	Internal regulator	LCD operating voltage																			
H	ON	ON	Internal converter circuit																			
L	OFF	OFF	External Input																			
33~38 42~47	C1P C1N	Capacitor connect terminal for Voltage Booster																				
147	RSTb	Reset When RSTb is "Low", latch circuit is reset.																				
138	CSb	Chip select When CSb is "L", data can be read in.("H"=input data invalid)																				
141	SI	Serial data input																				
144	SCL	Serial clock input terminal (MAX:2MHz)																				
135	OSC1	OSC1:External resistor and capacitance connection terminal for CR oscillation, or external clock input terminal																				
230	OSC2	OSC2:OSC output terminal																				
128	EXOSC	"High"=External clock input, "Low"=C R connect,																				
188 195	CSEL0 CSEL1	Test terminal Keep "L"(VPD short)																				
175	WSEL	Operation wave form "High"=dot reversing (A wave form) "Low"=line reversing (B wave form)																				
202,209 216	TEST0~TEST2	Test terminal Keep "L"(VPD short)																				

No.	Pad Name	Function
223	TEST3	STATIC operation select terminal("H"=STATIC, "L"=T1/T2 select)
233	SO	Test terminal Keep open
255~263 479~487	COMA0~COMA8 COMB8~COMB0	Common driver outputs COMAn=COMBn (COMA0=COMB0, ~COMA8=COMB8) When this terminal is not used, should be open.
264~309 315~368 374~427 433~478	SEG0~ SEG45 SEG46~ SEG99 SEG100~SEG153 SEG154~SEG199	Segment driver outputs

Note) Dummy PAD between the terminals description is skipped .

■ FUNCTION DESCRIPTION

- (1) Shift Resister
205 bits resister
- (2) Latch Circuit
Data stored in display data register is assigned to the corresponding SEG.
- (3) Segment Driver
Basing on display data, segment drivers output LCD SEG driving signal.
- (4) Common Driver
Common drivers output LCD COM driving signal.
- (5) Voltage converter/ Regulator
The voltage input to the VCI terminal is boost 2-times($V_{CI} \times 2$). Please set the input so that the output should not exceed 12V. When you can contrast adjustment, V_0 voltage can be decided by adjusting V_{REF} voltage. When Internal booster circuit is not used, should be $C1N$, $C1P$ open and should be V_{CI} , V_{REF} keep GND.

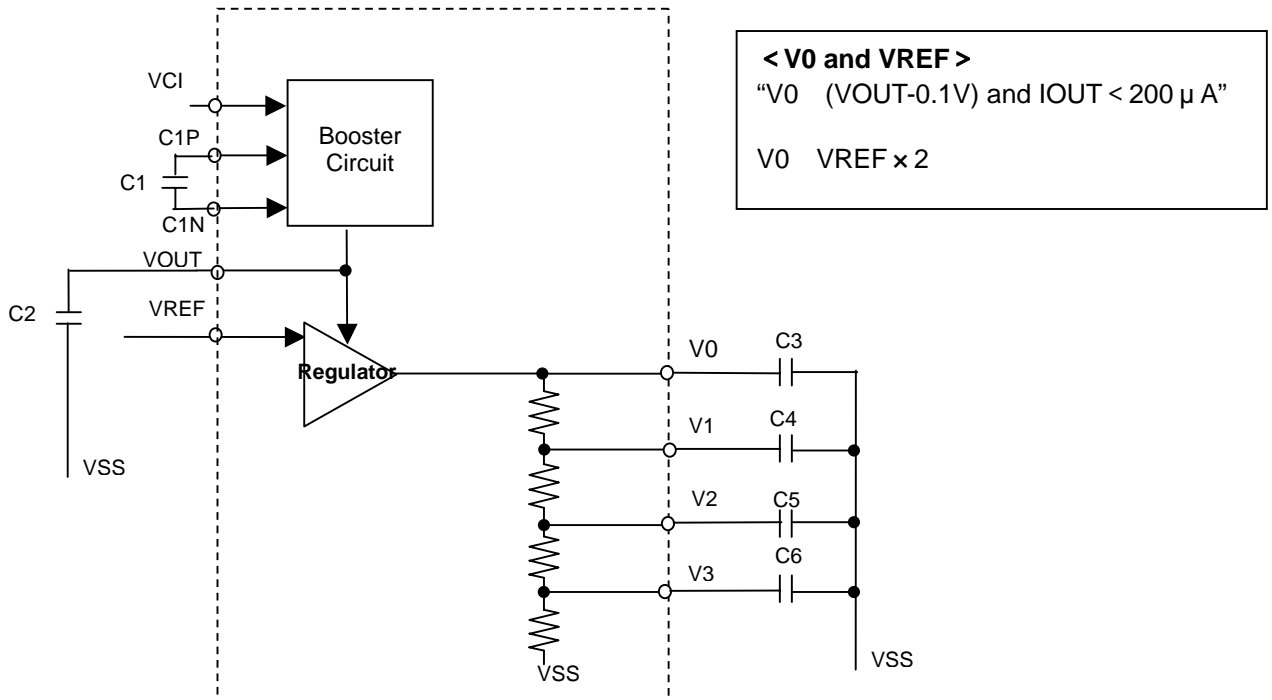

Fig Voltage booster curcuit

(6) Bleeder Resistance

LCD driving voltage generation circuit generates LCD driving bias voltages V0, V1, V2 and V3. Vout, V0, V1, V2 and V3 terminals requires external capacitors for bias voltage stabilization for display quality. These values of capacitors should be fixed in accordance with evaluation in the application. When setting it 1/1DUTY(Static), the bleeder resistance suppresses current consumption by FET.

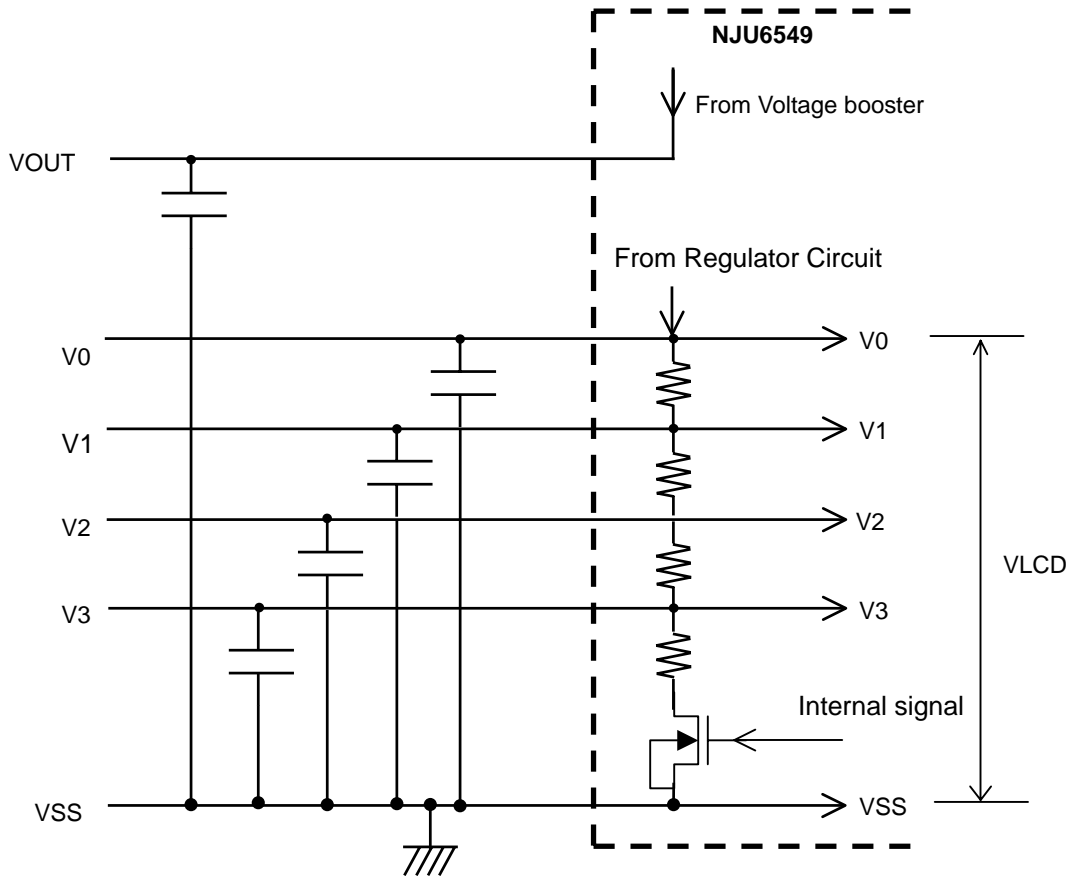

Fig Bleeder Resistance

(7) Oscillator circuit

The oscillator includes an external capacitor and an resistor. It generates clock signal for LCD driving. When use external clock, input the clock signal to OSC.(EXOSC Terminal is "High" when use external clock)

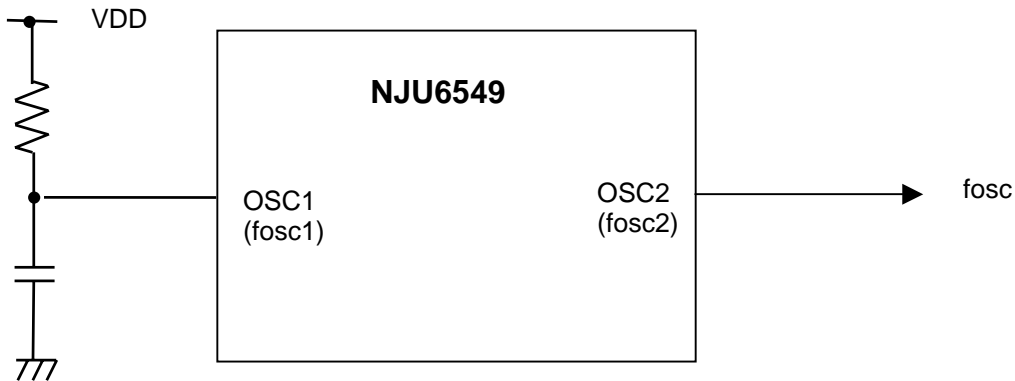

Fig OSC Circuit

(7-1) Oscillation frequency is provided by OSC2 terminal.

Mode	Relation between OSC1 and OSC2	Relation fosc
CR connect mode (EXOSC="Low")	The frequency of 1/2 set with OSC1 is output to OSC2.	$F_{osc} = f_{osc2} = 0.5 \times f_{osc1}$
CR external clock input terminal (EXOSC="High")	The frequency input to OSC1 is output to OSC2.	$F_{osc} = f_{osc2} = f_{osc1}$

(7-2) Relation between Oscillation frequency and Frame frequency

DUTY	Frame frequency
STATIC	$f_{osc}/288$ (A wave form) $f_{osc}/576$ (B wave form)
1/3	$f_{osc}/288$
1/4	$f_{osc}/288$
1/8	$f_{osc}/288$
1/9	$f_{osc}/288$

When setting static, both A waves form and B wave form become the same wave form. However, the frame frequency is different.

Wave form is different, except when static. However, the frame frequency is the same.

Note) Please set the frequency of the frame in SPEC(Electrical characteristics).

(8) Operating wave form

The NJU6549 can select dot inverse wave form(A wave form) or line inverse wave form(B wave form).

WSEL SET	
WSEL terminal set	Operating wave form
High	A wave form
Low	B wave form

(9) Input Data Format and Timing

Data format is shown below.

When the CSb terminal goes to "L" at SCL terminal "H", I/F is data input. Data fetched at SCL rising edge.

In case of entering less then 205-bit data, Malfunction. In case of entering over then 205-bit data, valid data is last 205-bit data.

(9-1) Input Data Timing 1/9Duty

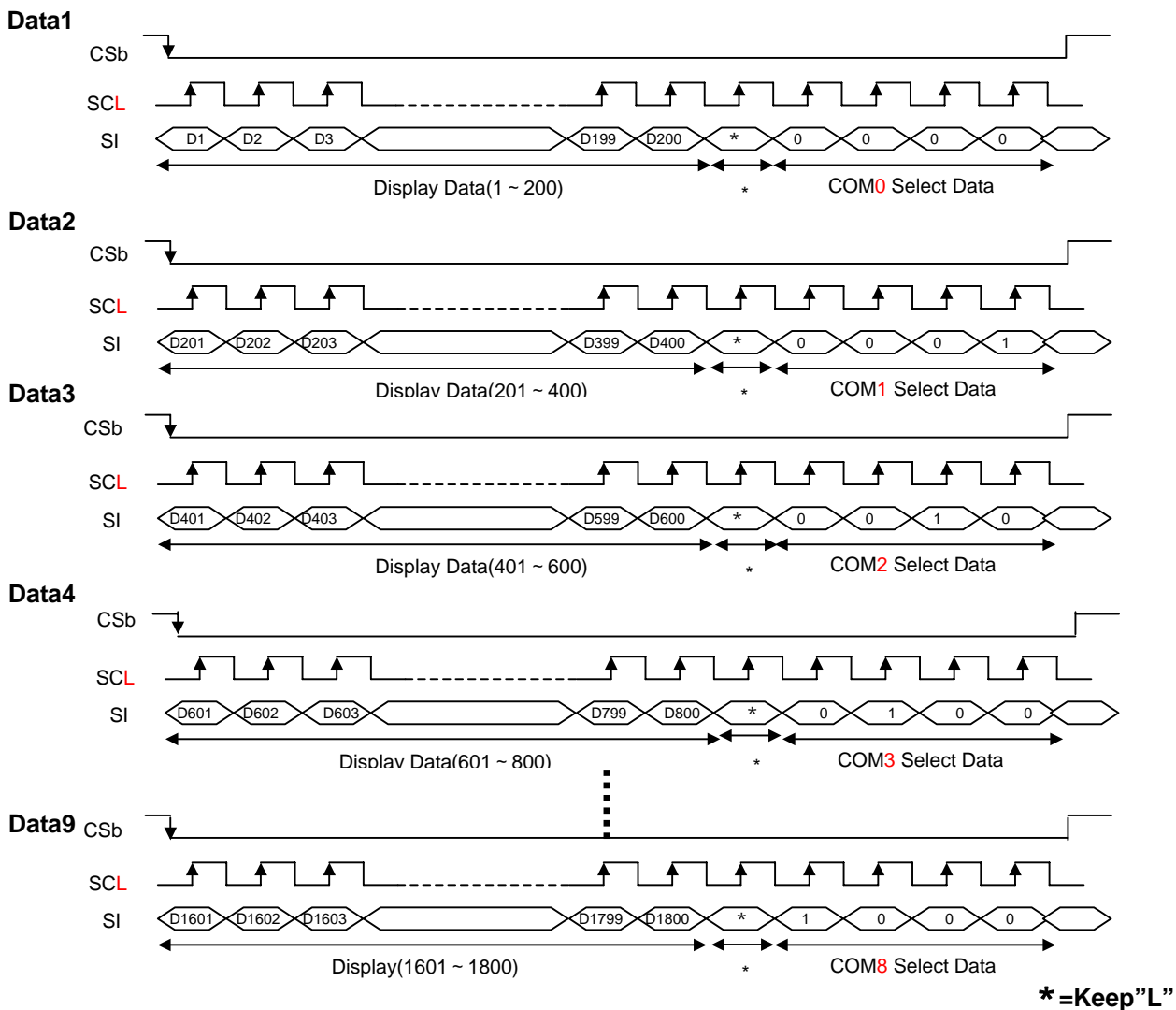

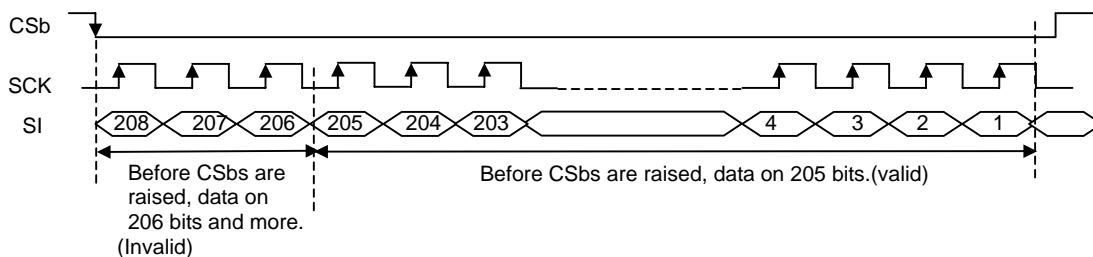

In case of entering over then 205-bit data

The number of write data is different because of the DUTY(T1,T2,TEST3) setting.
The Data become invalid when data except for the COM select are inputted.

DUTY vs. Forward Data

DUTY	Forward Data	Valid COM Select Data
STATIC	Data1	"0000"
1/3	Data1~Data3	"0000"~"0010"
1/4	Data1~Data4	"0000"~"0011"
1/8	Data1~Data8	"0000"~"0111"
1/9	Data1~Data9	"0000"~"1000"

(9-2) Display OFF (INHb)

When INHb is "H", display is ON, and when INHb is "L", display is off.

When INHb="L"

All segment and common terminal output Vss

(9-3) DUTY/BIAS Select (T1,T2,TEST3 Terminal)

T1 and T2, TEST3 terminal can select DUTY and BIAS.

When it is Display ON, DUTY and BIAS cannot be selected.

TEST3 select	T1 select	T2 select	DUTY	BIAS
H	*	*	STATIC	1/1BIAS
L	L	L	1/3DUTY	1/3BIAS
L	L	H	1/4DUTY	1/3BIAS
L	H	L	1/8DUTY	1/4BIAS
L	H	H	1/9DUTY	1/4BIAS

(9-4) Voltage Converter Circuit Select (BOOST terminal)

BOOST Terminal select

BOOST select	Voltage booster circuit	Regulator circuit	LCD operating supply
H	Valid	Valid	Internal Converter Circuit valid
L	Invalid	Invalid	External VLCD power supply Input

(9-5) Reset(RSTb)

When RSTb is "Low", latch circuit is reset.

But, Display ON/OFF and DUTY/BIAS can not be reset.

Power supply sequence when reset operation is not done)

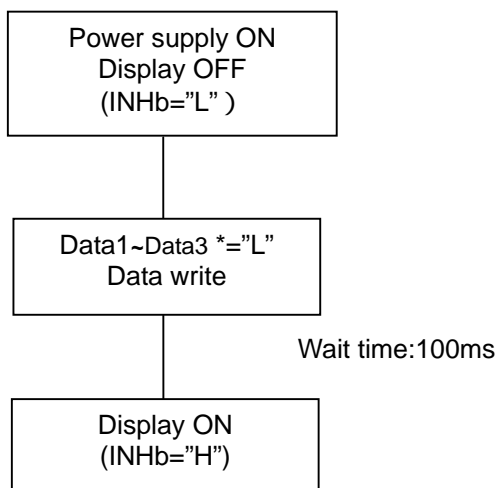

■ FORWARD DATA AND OUTPUT TERMINAL

	COM0	COM1	COM2	COM3	COM4	COM5	COM6	COM7	COM8
COM Select Data	0000	0001	0010	0011	0100	0101	0110	0111	1000
SEG0	D1	D201	D401	D601	D801	D1001	D1201	D1401	D1601
SEG1	D2	D202	D402	D602	D802	D1002	D1202	D1402	D1602
SEG2	D3	D203	D403	D603	D803	D1003	D1203	D1403	D1603
SEG3	D4	D204	D404	D604	D804	D1004	D1204	D1404	D1604
SEG4	D5	D205	D405	D605	D805	D1005	D1205	D1405	D1605
SEG5	D6	D206	D406	D606	D806	D1006	D1206	D1406	D1606
SEG6	D7	D207	D407	D607	D807	D1007	D1207	D1407	D1607
SEG7	D8	D208	D408	D608	D808	D1008	D1208	D1408	D1608
SEG8	D9	D209	D409	D609	D809	D1009	D1209	D1409	D1609
SEG9	D10	D210	D410	D610	D810	D1010	D1210	D1410	D1610
SEG190	D191	D391	D591	D791	D991	D1191	D1391	D1591	D1791
SEG191	D192	D392	D592	D792	D992	D1192	D1392	D1592	D1792
SEG192	D193	D393	D593	D793	D993	D1193	D1393	D1593	D1793
SEG193	D194	D394	D594	D794	D994	D1194	D1394	D1594	D1794
SEG194	D195	D395	D595	D795	D995	D1195	D1395	D1595	D1795
SEG195	D196	D396	D596	D796	D996	D1196	D1396	D1596	D1796
SEG196	D197	D397	D597	D797	D997	D1197	D1397	D1597	D1797
SEG197	D198	D398	D598	D798	D998	D1198	D1398	D1598	D1798
SEG198	D199	D399	D599	D799	D999	D1199	D1399	D1599	D1799
SEG199	D200	D400	D600	D800	D1000	D1200	D1400	D1600	D1800

■ OPERATING WAVE FORM

1)STATIC

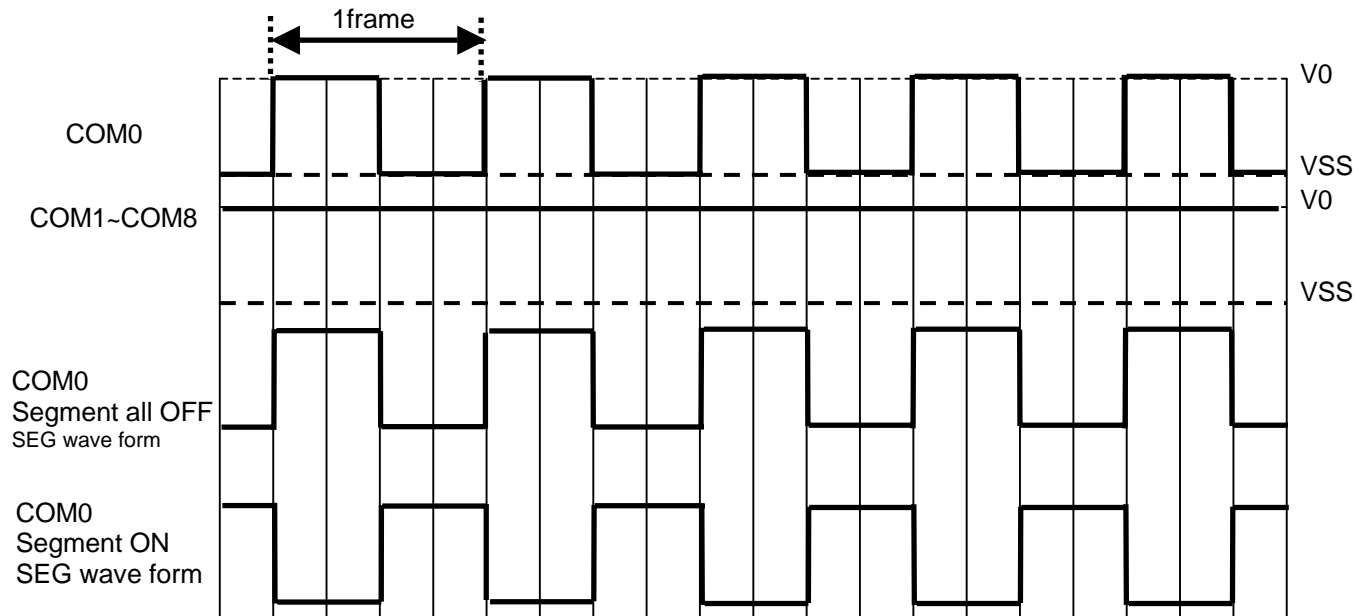

OPERATING WAVE FORM(A WAVE FORM)

1) 1/3DUTY, 1/3BIAS

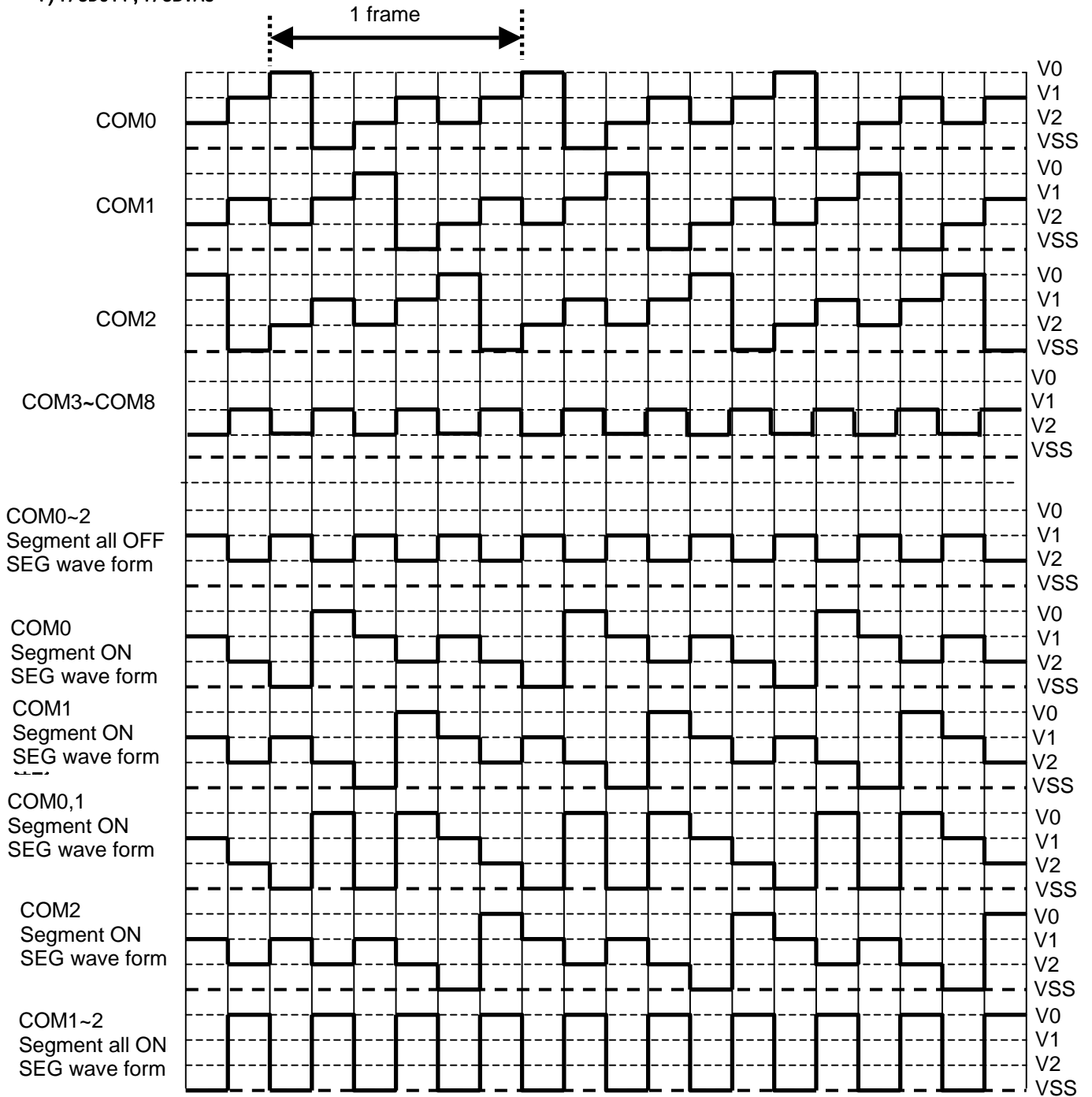

2)1/4DUTY,1/3BIAS

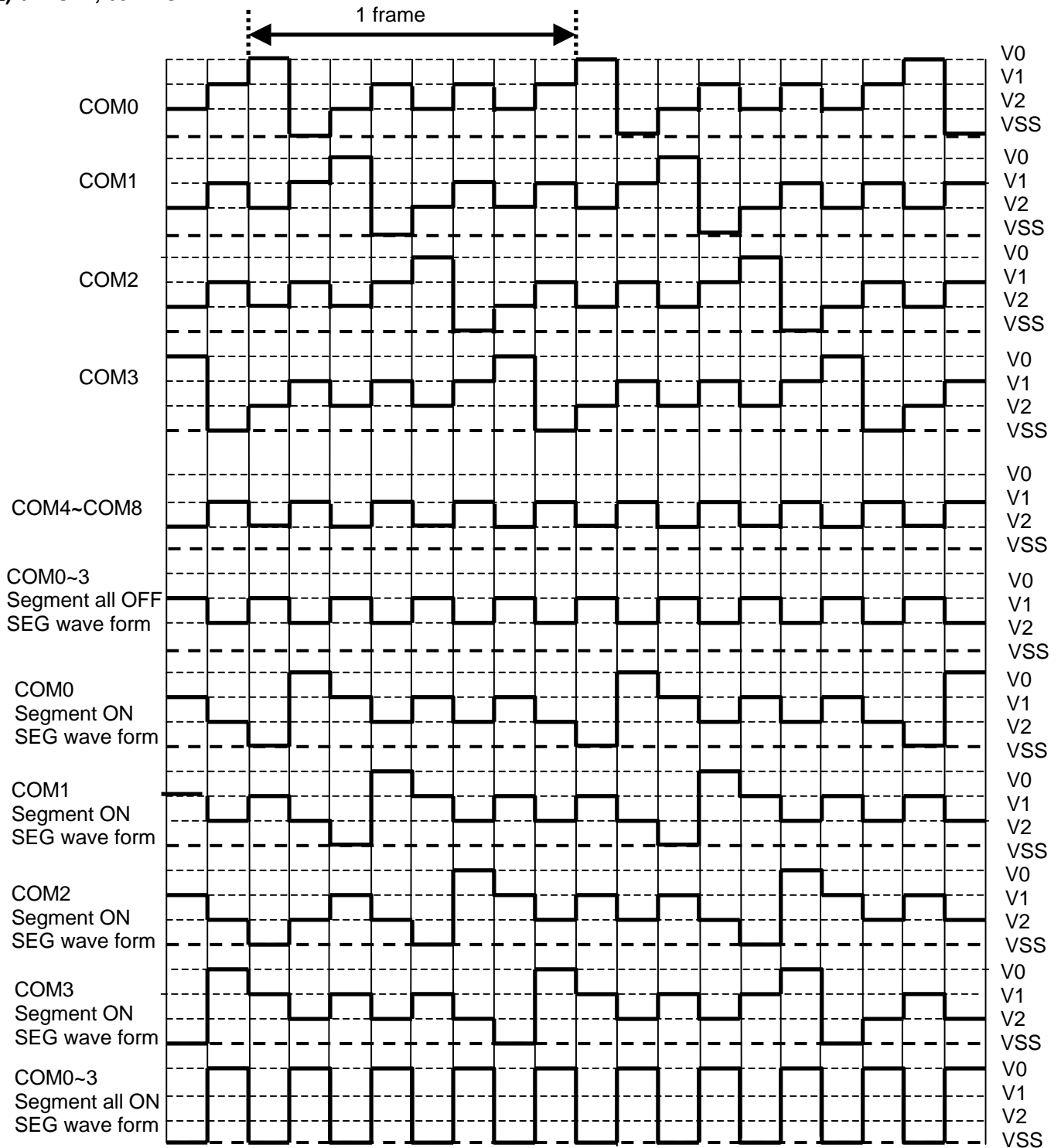

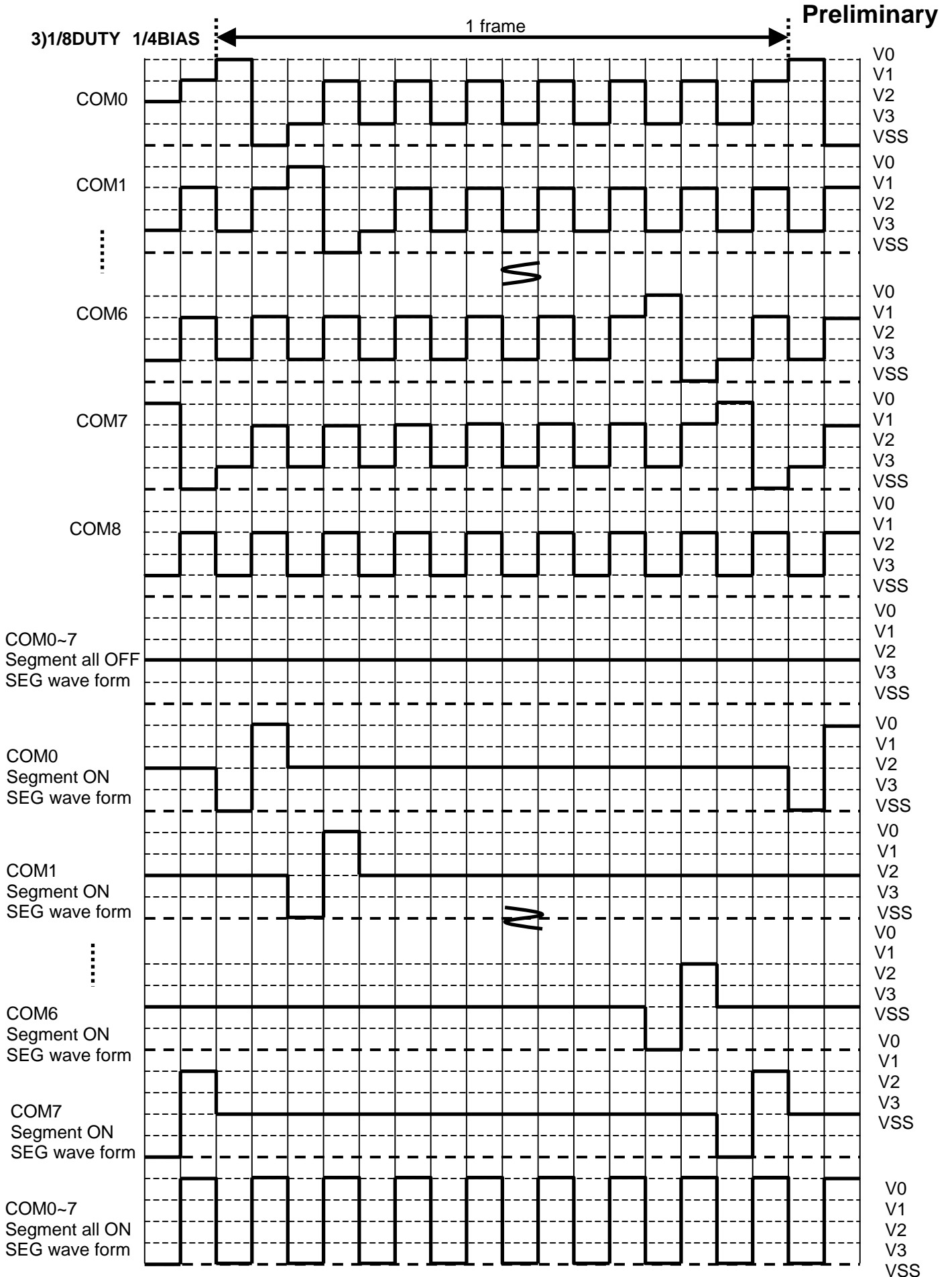

2)1/9DUTY, 1/4BIAS

1 frame

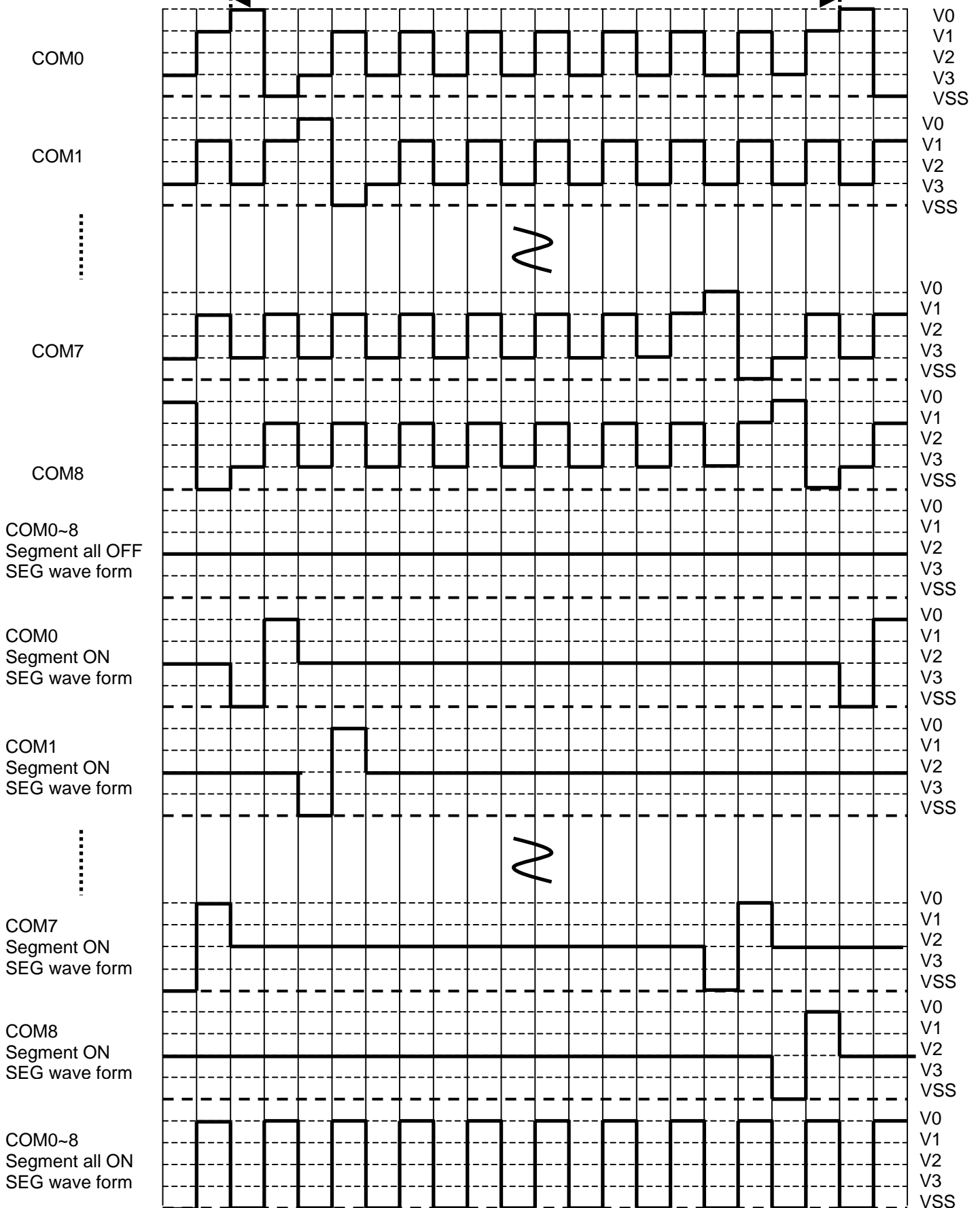

OPERATING WAVE FORM(B WAVE FORM) 1)1/3DUTY 1/3BIAS

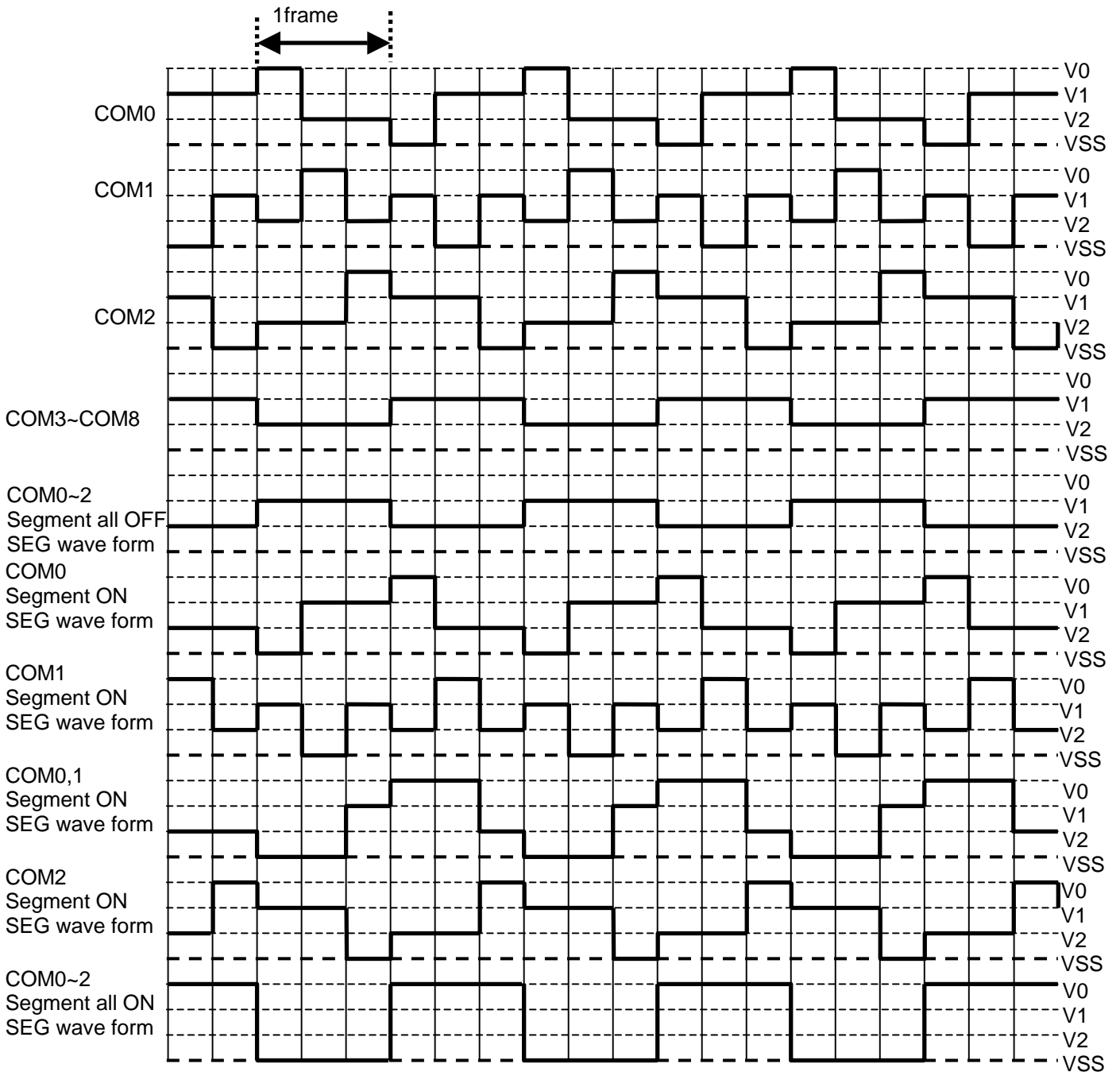

2)1/4DUTY,1/3BIAS

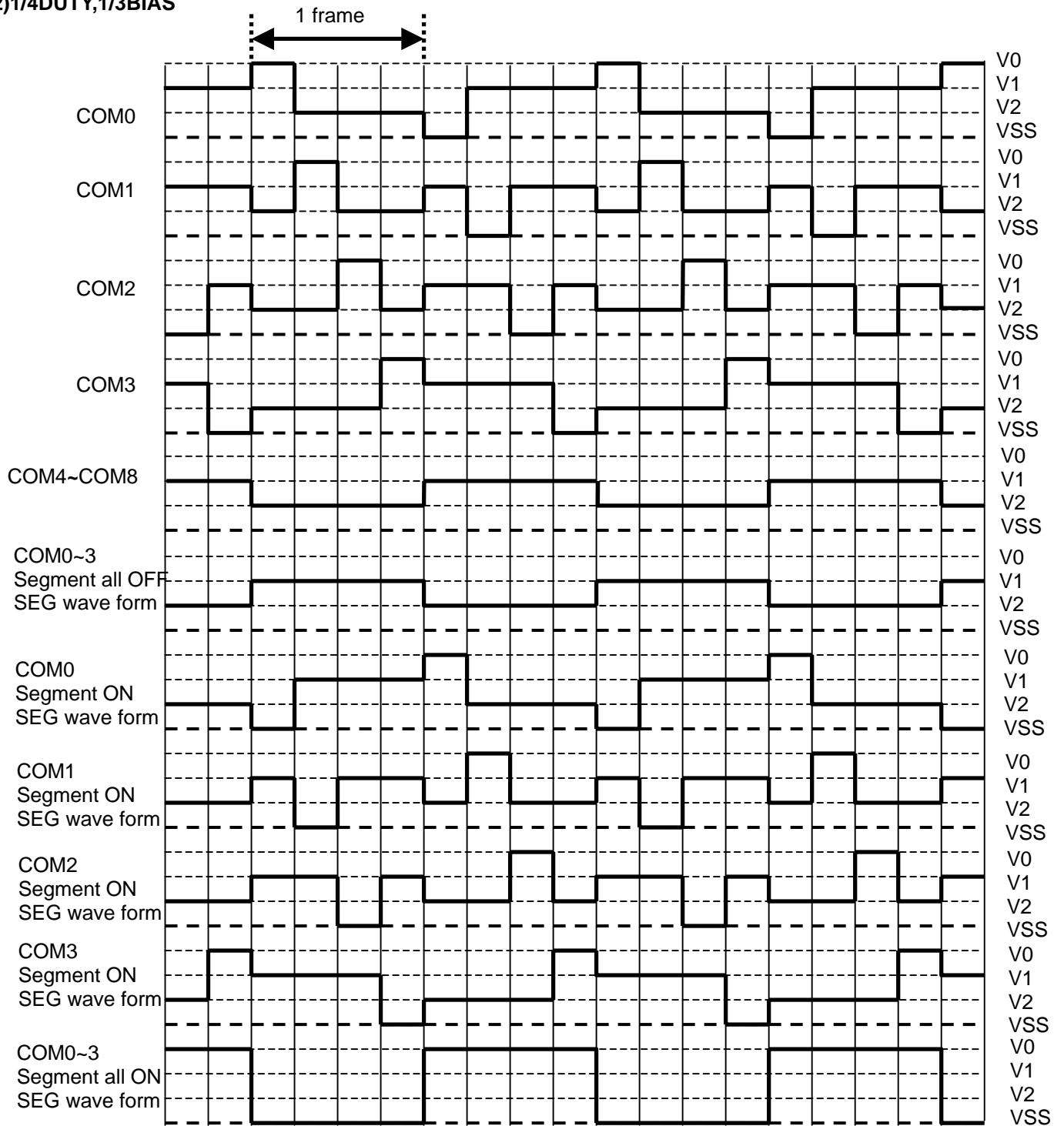

2)1/8DUTY 1/4BIAS

1frame

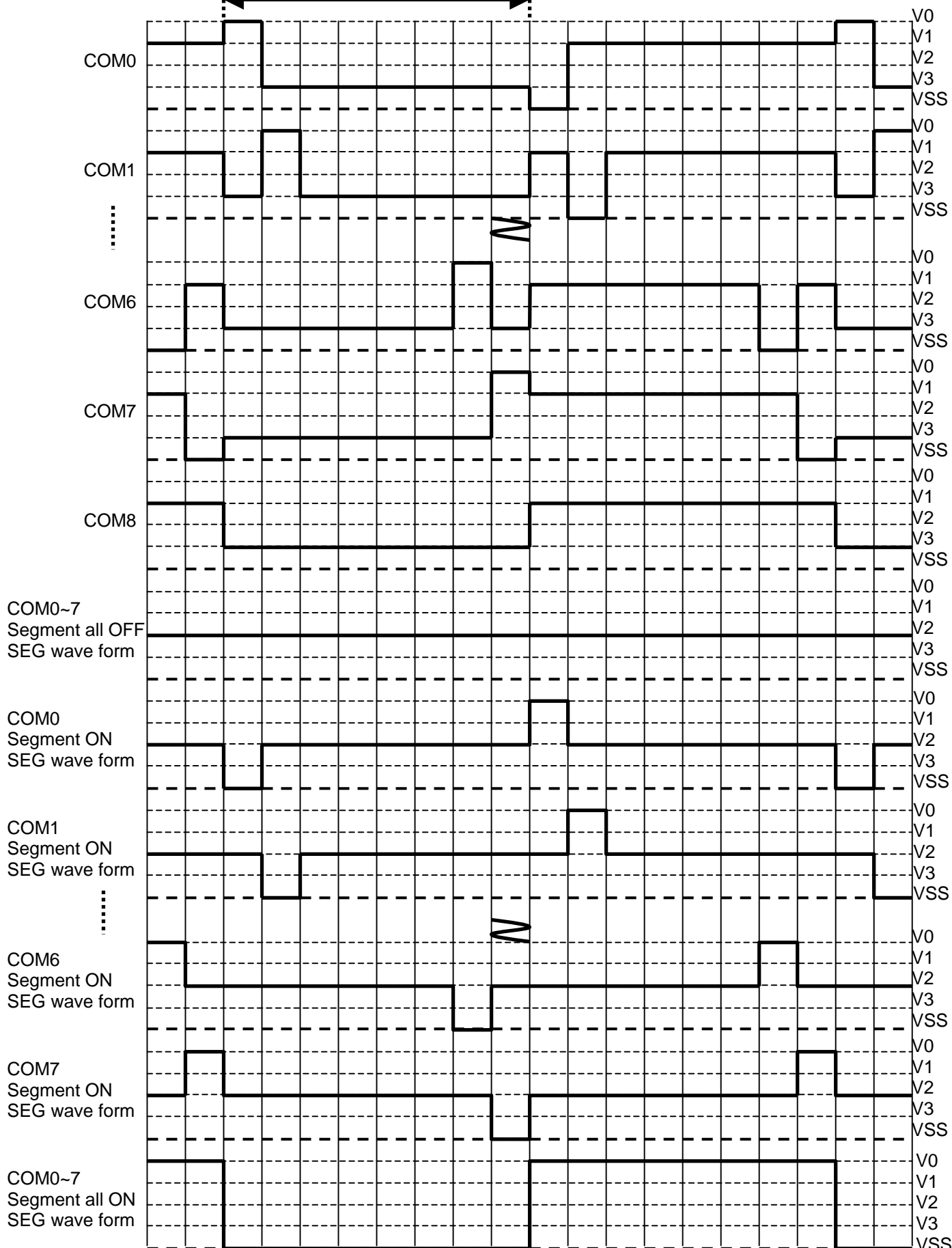

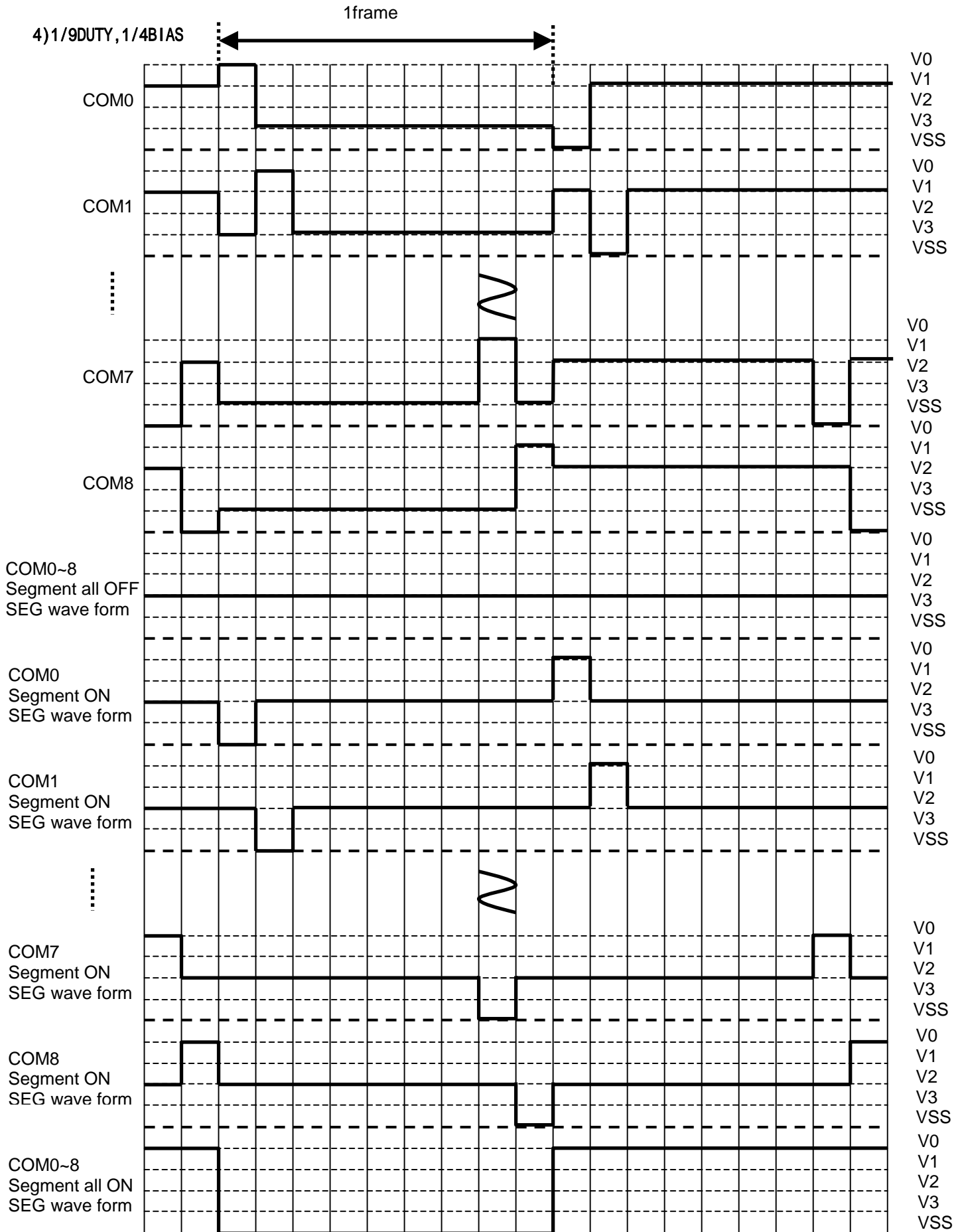

■ ABSOLUTE MAXIMAM RATINGS

($V_{SS}=0V$, $T_a=25^{\circ}C$)

PARAMETER	SYMBOL	RATINGS	UNIT	CONDITIONS
Supply Voltage 1	V_{DD}	-0.3 ~ +7.0	V	
Supply Voltage 2	V_{CI}	-0.3 ~ +6.5	V	V_{CI} Terminal Note-4)
Supply Voltage 3	V_{OUT}, V_0 $V_1 \sim V_3$	-0.3 ~ +13.5	V	$V_{OUT}, V_0, V_1 \sim V_3$ Terminal
Input Voltage	V_t	-0.3 ~ $V_{DD}+0.3$	V	OSC1, SCL, SI, CSb, RSTb, VREF, INHb, T1, T2, BOOST, applicable.
Operating Temp.	T_{opr}	-40 ~ +105	$^{\circ}C$	
Storage Temp.	T_{stg}	-55 ~ +125	$^{\circ}C$	

- Note-1) Do not exceed the absolute maximum ratings, otherwise the stress may cause a permanent damage to the IC. It is also recommended that the IC be used within the range specified in the DC electrical characteristics, or the electrical stress may cause mulfunctions and impact on the reliability.
- Note-2) To stabilize the LSI operation, place decoupling capacitors between $V_{DD}-V_{SS}$, $V_{CI}-V_{SS}$ and between $V_{OUT}-V_{SS}$.
- Note-3) All voltages are relative to $V_{SS} = 0V$ reference. The following relationship shall be maintained.
 $V_{OUT} \geq V_0 \geq V_{DD} > V_{SS}$, and $V_{SS} = 0V$
- Note-4) When voltage doublers circuit, need condition of $13.5V \geq V_{CI} \times 2$.

ELECTRICAL CHARACTERISTICS

DC characteristics

($V_{DD}=4.0$ to $5.5V$, $V_{SS}=0V$, $T_a=-40$ to $105^{\circ}C$)

PARAMETER	SYMBOL	Terminal	CONDITIONS	MIN	TYP	MAX	UNIT	Note
Power Supply 1	V_{DD}	V_{DD}		4.0		5.5	V	
Power Supply 2	V_{CI}	V_{CI}		2.7		6.0	V	
Power Supply 3	V_{OUT}	V_{OUT}		V_{DD}		12.0		
Input voltage	V_{IH1}	OSC1, SCL, SI CSb, RSTb		$0.8 V_{DD}$		V_{DD}	V	
	V_{IL1}	INHb, T1, T2 BOOST EXOSC		V_{SS}		$0.2 V_{DD}$	V	
Driver-on Resistance (COM)	R_{COM}	COMA0-COMA8 COMB0-COMB8	$\pm I_d=1\mu A$ (COM Terminal) V_0, V_{SS}, V_1, V_3			20	kOhm	5
Driver-on Resistance (SEG)	R_{SEG}	SEG0-SEG199	$\pm I_d=1\mu A$ (SEG Terminal) V_0, V_{SS}, V_2			20	kOhm	5
Input leakage current	I_{LI}	OSC1, SCL, SI CSb, RSTb INHb, T1, T2 BOOST EXOSC	$V_{IN}=0\sim V_{DD}$	-1.0		1.0	μA	
Operating Current	I_{DD1}	V_{DD}	$V_{DD}=5V, V_{CI}=5V, V_0=9V,$ $f_{OSC}=40kHz,$ Checker flag display, Booster ON WSEL=H(A wave form) (COM/SEG open)		75	150	μA	6
	I_{CI}	V_{CI}			500	700		
LCD operating voltage	V_1	V_1	$V_0=9.0V$ (COM/SEG open)		6.75		V	7
	V_2	V_2			4.50			
	V_3	V_3			2.25			
Bleeder resistance	R_B	Between V_0 and V_{SS}	$V_0=9V, T_a=25^{\circ}C$	45	55	65	kOhm	
Booster output voltage	V_{OUT}	V_{OUT}	$V_{CI}=5V, T_a=25^{\circ}C$ $f_{OSC}=40kHz,$ Booster ON (COM/SEG open)	9.5		10	V	8
OSC frequency	f_{OSC}	OSC2	$V_{DD}=5V, T_a=25^{\circ}C,$ $R_{OSC}=120k\Omega$ $C_{OSC}=100pF$ EXOSC=L	34	40	46	kHz	9
Frame frequency	F_r	COM	1/3, 1/4, 1/8, 1/9 DUTY	64	128	400	Hz	10
External clock Duty	Duty	OSC1	External input	40	50	60	%	
Regulator	V_{REF}	V_{REF}		1.5		V_{CI}	V	
	V_0	V_0	$V_{OUT}=9V, V_{REF}=4.25V, I_O=0A$	$1.9 \times V_{REF}$	$2.0 \times V_{REF}$	$2.1 \times V_{REF}$	V	
	Delta VIO	Between V_0 and V_{OUT}	$V_{OUT}=9V, I_O=-200\mu A$			0.1	V	

Note-5) Driver-On resistance (R_{SEG}/R_{COM}) is measured from V_0, V_{SS}, V_1, V_2 or V_3 terminal to each SEG/COM terminal when I_d current flows through COM/SEG terminals.

Note-6) If input voltage is outside of the spec, when operating current increase. The input voltage must be inside the spec(V_{IH1}, V_{IL1}).

Note-7) The VLCD operating voltage depend on Internal resistance rate.

Note-8) Voltage booster output when 5V is input from external source to terminal VCI

Note-9) The OSC frequency is provided for by the output frequency of the terminal OSC2.

Note-10) The frame frequency changes depending on the OSC frequency.
(Refer to [Relation between Oscillation frequency and Frame frequency])

AC characteristics

($V_{DD}=V_0=4.0$ to $5.5V$, $V_{SS}=0V$, $T_a=-40$ to $105^{\circ}C$)

PARAMETER	SYMBOL	CONDITIONS	MIN	TYP	MAX	UNIT	Note
"L" Level Clock Pulse Width	t_{WCLL}		230			ns	
"H" Level Clock Pulse Width	t_{WCLH}		230			ns	
Data Setup Time	t_{DS}		20			ns	
Data Hold Time	t_{DH}		20			ns	
CSb Setup Time	t_{CS}		50			ns	
CSb Hold Time	t_{CH}		50			ns	
CSb"H" Level Pulse Width	t_{WCH}		250			ns	
Rising Time	t_r				20	ns	
Falling Time	t_f				20	ns	

• Input Timing

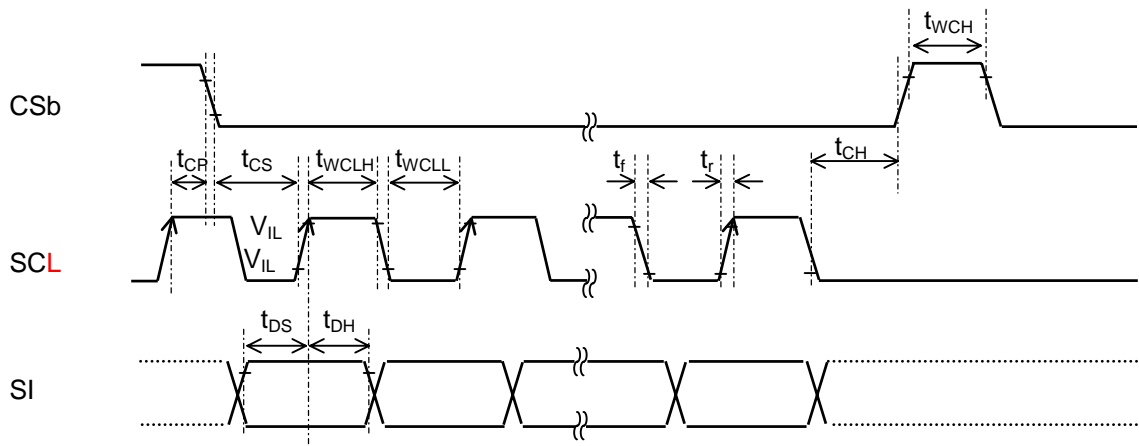

• Input condition when hardware reset circuit is used

($T_a=25^{\circ}C$)

PARAMETER	SYMBOL	CONDITIONS	MIN	TYP	MAX	UNIT
Reset Input "L" Level Width	t_{RSL}		1.3			ms
Reset Rising Time	t_{RFS}				100	ns
Reset Falling Time	t_{RFS}				100	ns

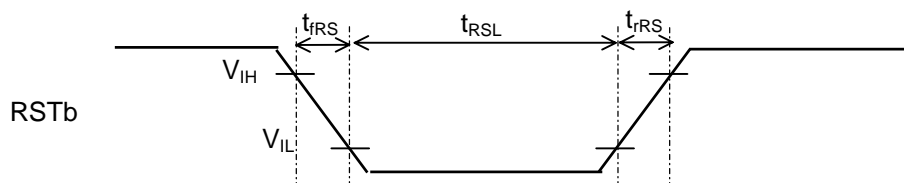

■ CHARACTERISTIC(OSC frequency)

Condition: VDD=5V, VSS=0V, Capacitor C7=100pF(include wiring capacitor), R3=from 20kohm to 470kohm

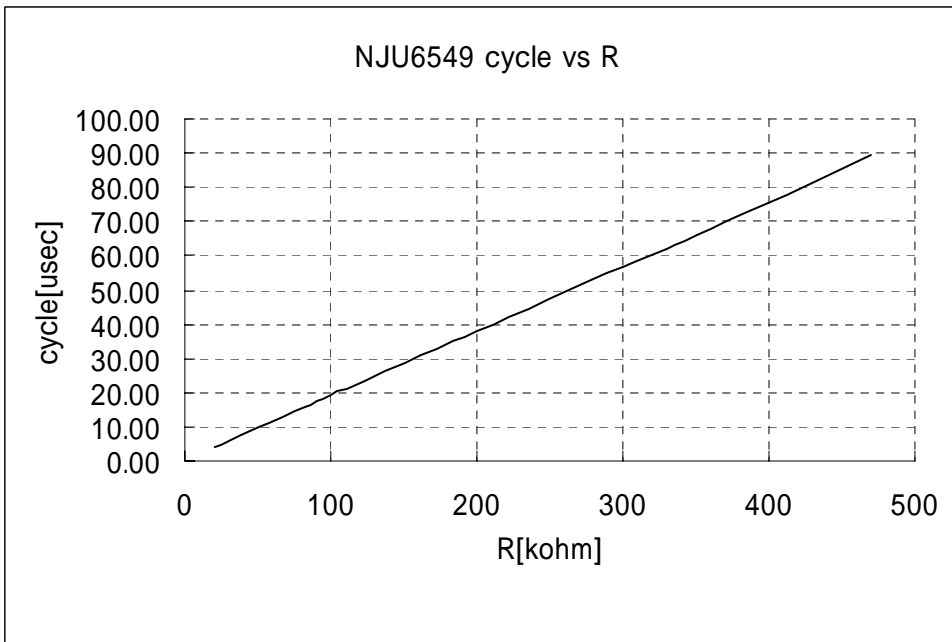
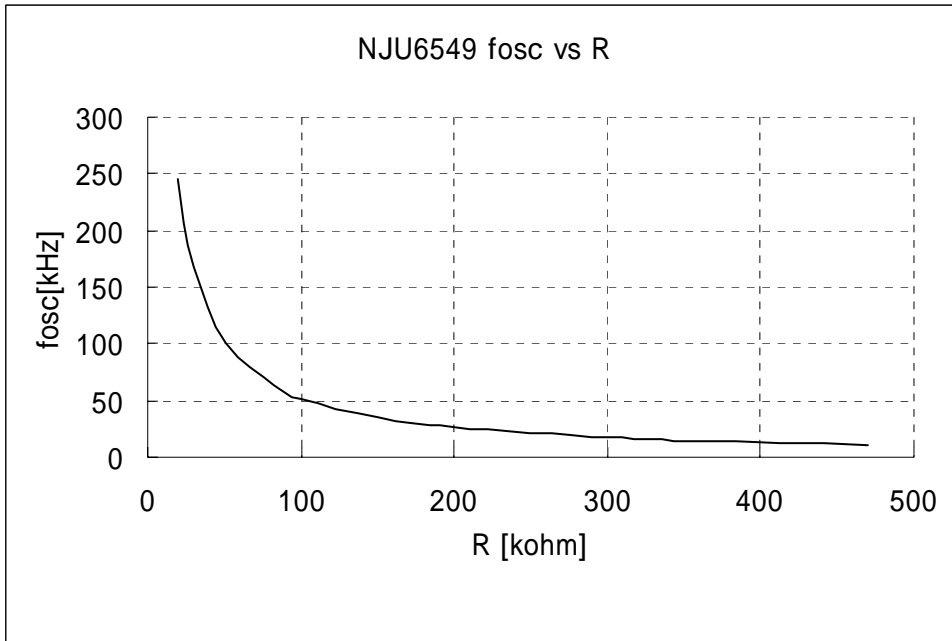

This graph is an ability value, and no one to guarantee the characteristic.

APPLICATION CIRCUIT

1)1/9DUTY, 1/4BIAS, Boost=ON, OSC=CR

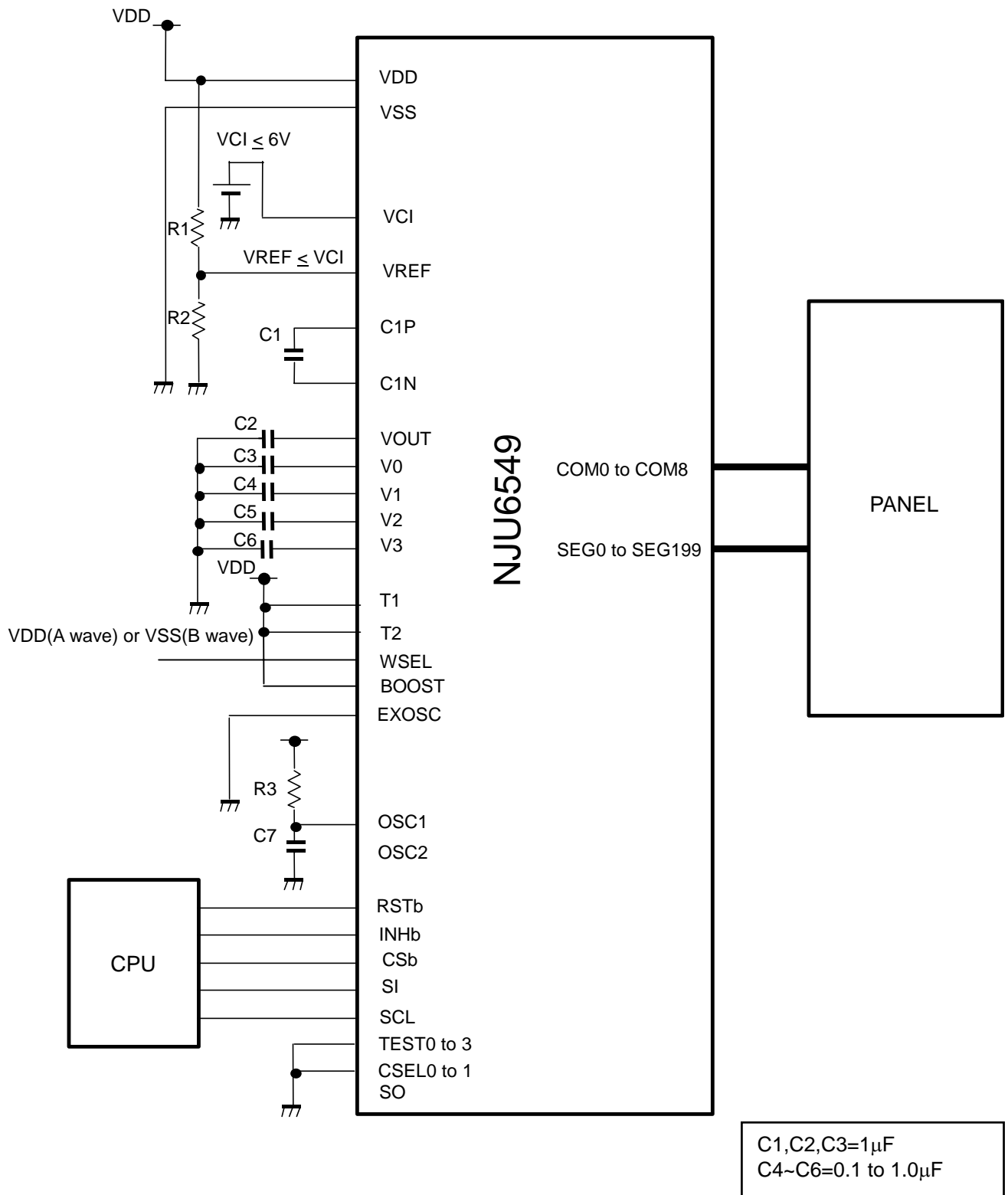

2)1/3DUTY, 1/3BIAS, Boost=ON, OSC=CR

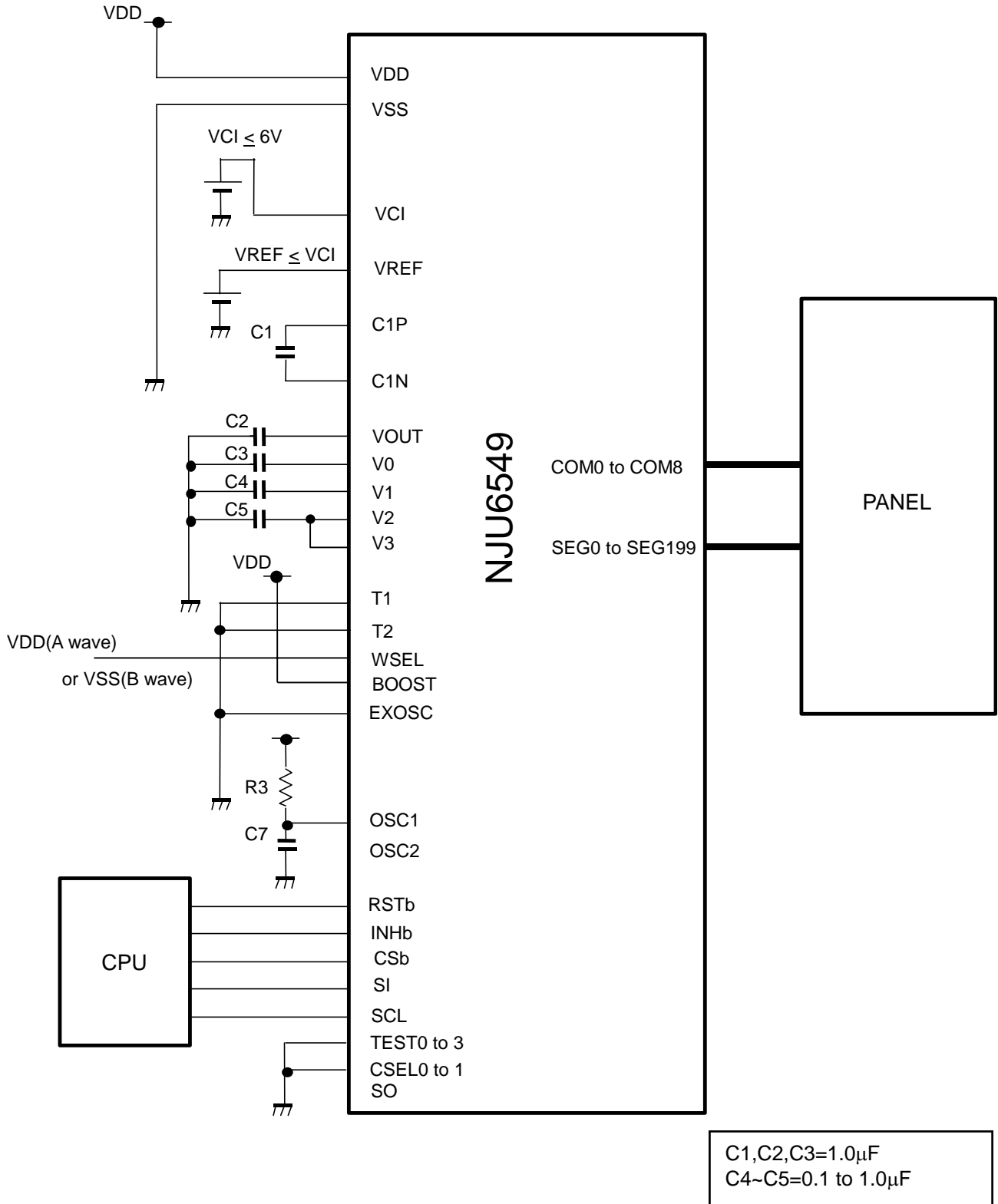

3)1/9DUTY, 1/4BIAS, Boost=OFF(External supply), OSC=CR

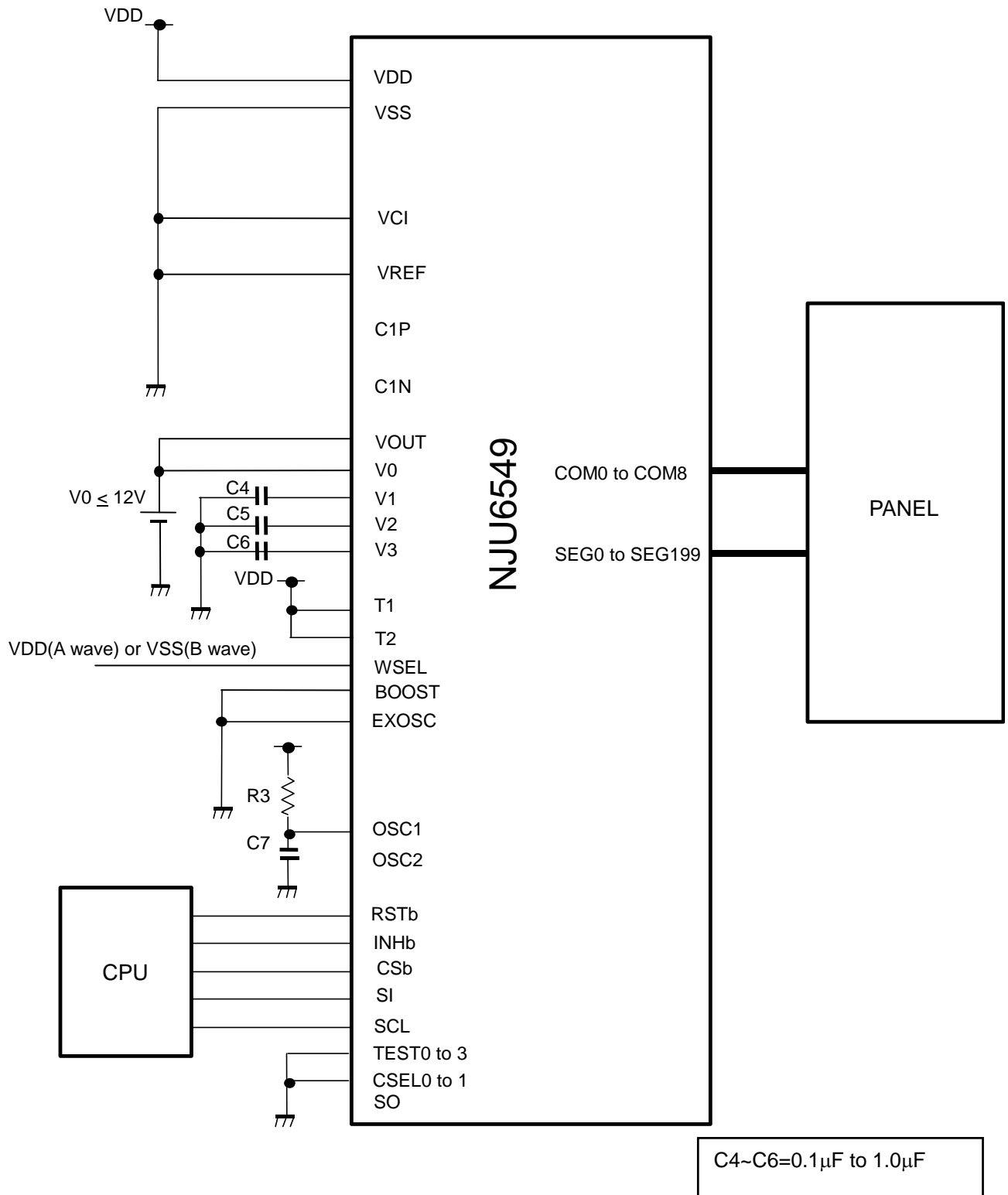

C4~C6=0.1µF to 1.0µF

4)1/3DUTY, 1/3BIAS, Boost=OFF(External supply), OSC= External input

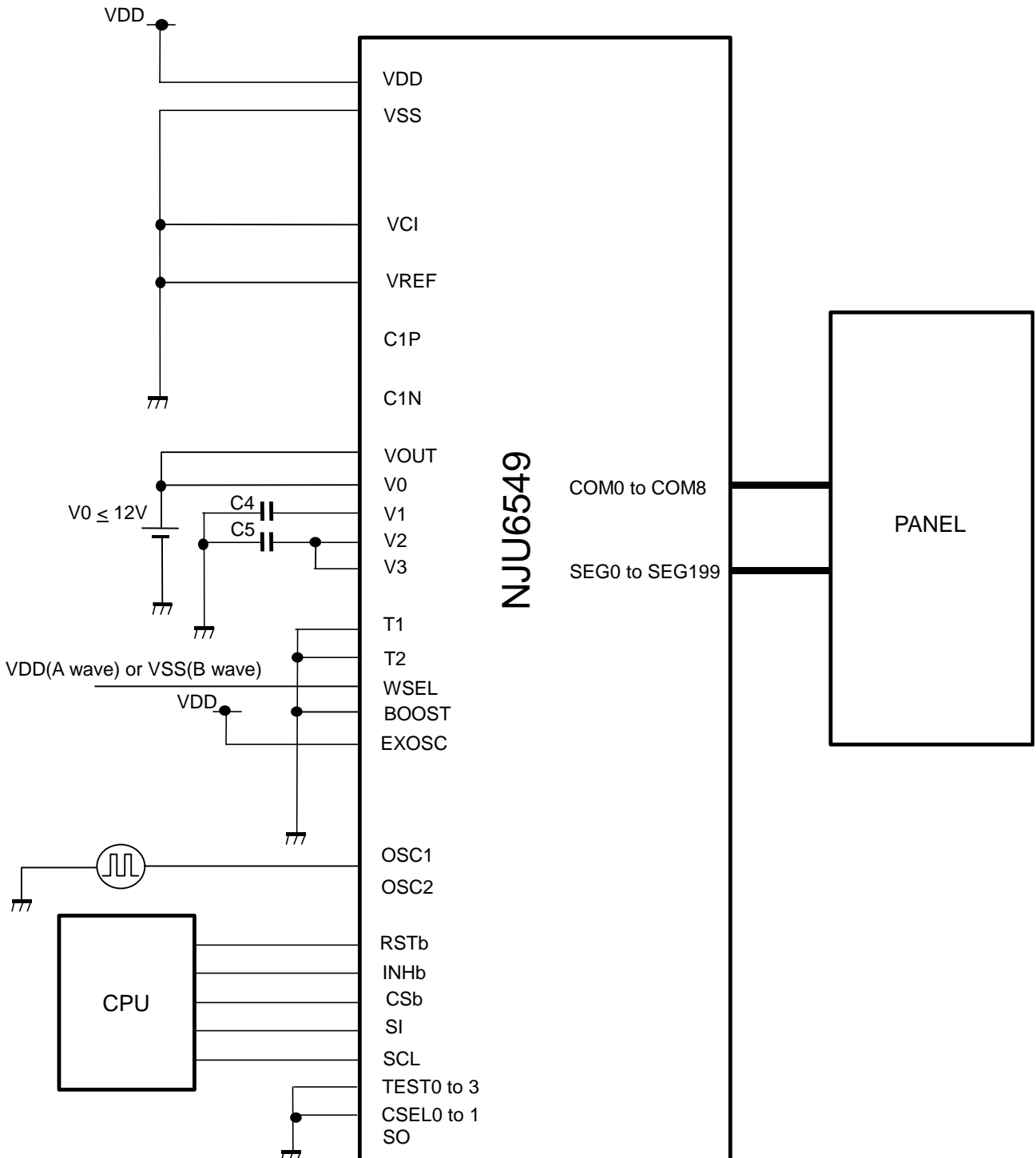

C4 to C5=0.1μF to 1.0μF

[CAUTION]
 The specifications on this databook are only given for information, without any guarantee as regards either mistakes or omissions. The application circuits in this databook are described only to show representative usages of the product and not intended for the guarantee or permission of any right including the industrial rights.