

Pre-Amplifier for MEMS Microphone

■GENERAL DESCRIPTION

The **NJU72084** is a pre-amplifier for MEMS microphone. The **NJU72084** has integrated low noise bias circuit for MEMS microphone, and high performance analog pre-amplifier deliver the genuine sound quality and support flexible microphone systems.

■PACKAGE OUTLINE



CHIP

■APPLICATIONS

- Portable Audio equipment
- MEMS Microphone module
- Cellular Phone

■FEATURES

- Operating Voltage 1.5V to 3.60V
- Current Consumption 80 μ A typ.
- Input equivalent noise 3 μ Vrms (-110dBV)
- Maximum output Voltage 281mVrms (-11dBV) at THD < 5%
- Gain -3dB
- Frequency response 20Hz to 20kHz
- Bias Voltage +12.5V
- Operating temperature -40°C to 85°C
- Package Chip (Wafer)

■BLOCK DIAGRAM

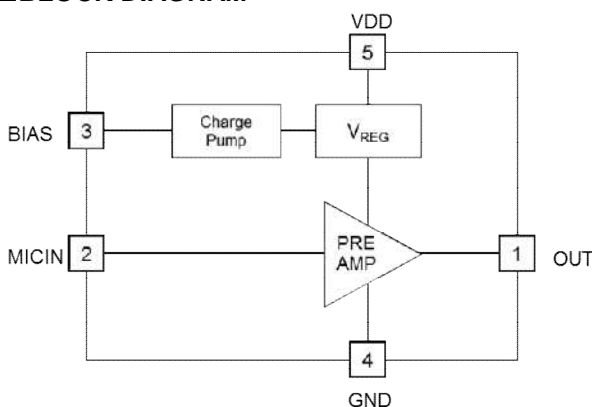

1	OUT	Output (Analog output)
2	MICIN	Microphone input (Analog input)
3	BIAS	Bias Voltage Output
4	GND	Ground
5	VDD	Power Supply

■ABSOLUTE MAXIMUM RATING (Ta=25°C)

PARAMETER	SYMBOL	RATING	UNIT
Power Supply Voltage	V _{DD}	5	V
Operating temperature	Topr	-40 to 85	°C
Storage temperature	Tstg	-40 to 125	°C
Maximum input Voltage	V _{IM}	±0.4	V

CAUTION

ESD Tolerance: Human Body Model 2000V, (MICIN and BIAS terminals : 500V)

■RECOMMENDED OPERATING CONDITIONS (Ta =25°C unless otherwise specified)

PARAMETER	SYMBOL	TEST CONDITION	MIN.	TYP.	MAX.	UNIT
Operating Voltage	V _{DD}		1.5	1.8	3.6	V

■ELECTRICAL CHARACTERISTICS

(Ta=25°C, V_{DD} =1.8V, Input Capacitance=1pF, Vin=-39.0dBV, f=1kHz, R_L=100kΩ unless otherwise specified)

PARAMETER	SYMBOL	TEST CONDITION	MIN.	TYP.	MAX.	UNIT
Current Consumption	I _{DD}		50	80	120	μA
Output Noise Voltage	V _{NO}	A-weighted	-	3 (-110)	-	μVrms (dBV)
Gain	V _G		-4.0	-3.0	-2.0	dB
Total Harmonic Distortion	THD+N	Vin=50mVrms(=-26dBV), filter=400Hz to 30kHz	-	0.2	1	%
Maximum Output Voltage	V _{OM}	THD<5%, filter=400Hz to30kHz	150 (-16.5)	281 (-11)	-	mVrms (dBV)
Cut Off Frequency	f _{CL}		-	-	20	Hz
Cut Off Frequency	f _{CH}		20	-	-	kHz
Power Supply Rejection Ratio	PSRR	f=217Hz, 0.1Vpp Square	-	-56	-	dB
Bias Voltage	V _{bias}		11.8	12.5	13.2	V
Output DC Impedance	Z _o	R _L =2.2kΩ	-	150	300	Ω
Start Up Time	trbs	Bias Voltage 90% rising	-	4	10	msec

■ TERMINAL DESCRIPTION

PIN NO.	SYMBOL	FUNCTION	EQUIVALENT CIRCUIT	TERMINAL VOLTAGE
5 4	VDD GND	Power Supply Ground		VDD 0V
2 1	MICIN OUT	Microphone input (Analog input) Output (Analog output)		0V 0.9V
3	BIAS	Bias Voltage Output		12.5V

MEASUREMENT CIRCUIT

[I_{DD} , V_{No}]

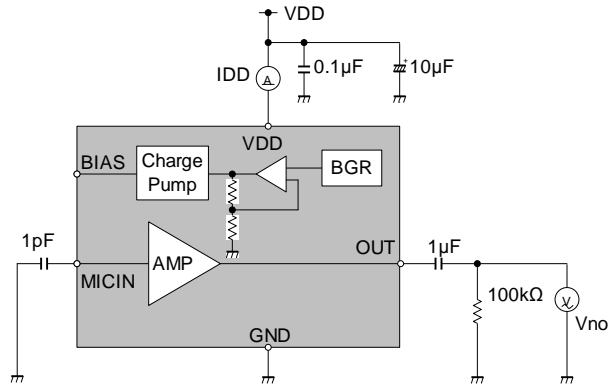

[V_G , THD+N]

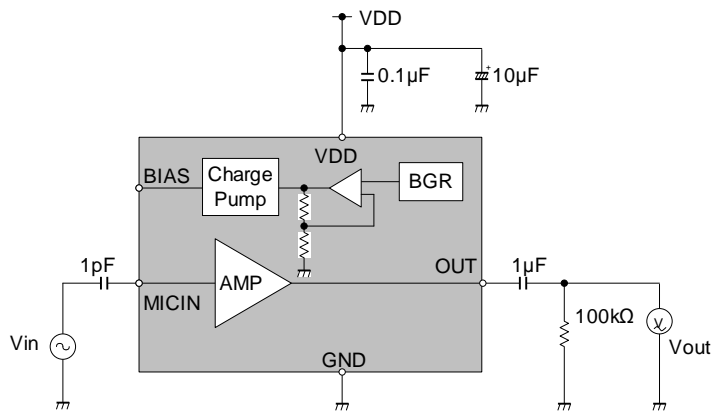

[PSRR]

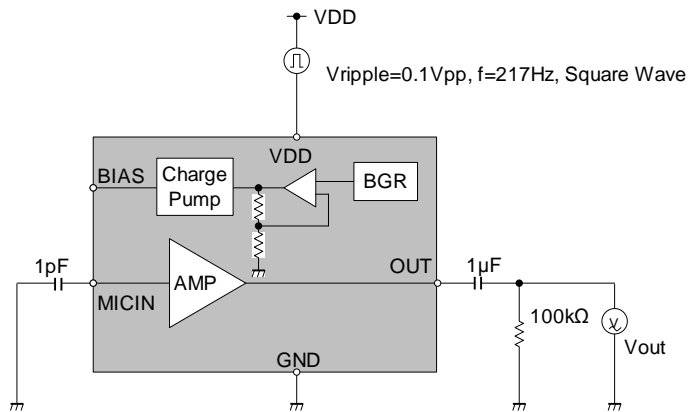

[V_{OM} , f_{CL} , f_{CH}]

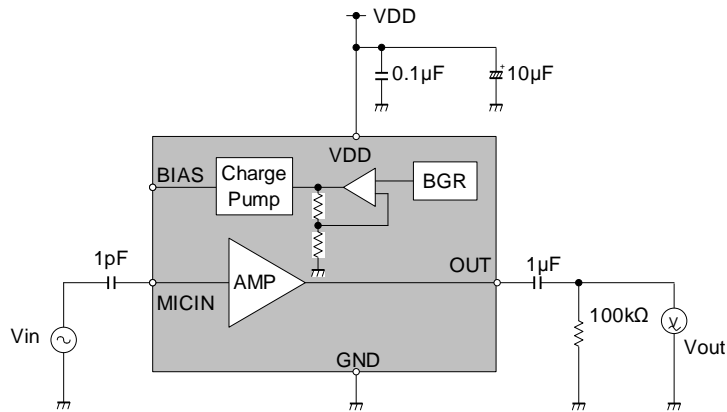

[Z_o]

$$Z_o = 100k \times \frac{1 - \frac{V_G - Measurement}{20}}{\frac{V_G - Measurement}{20} - \frac{100k}{2.2k}}$$

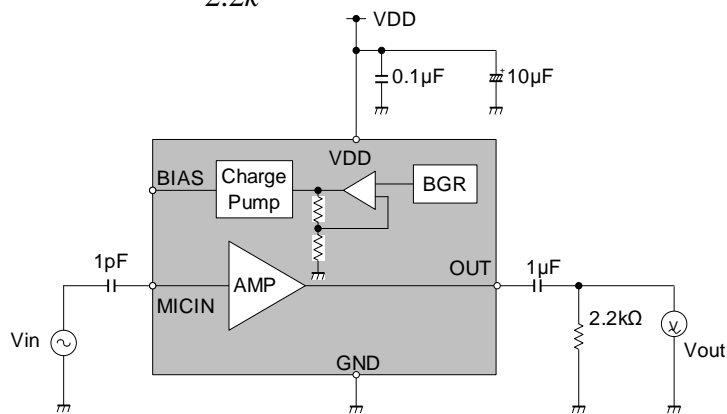

[V_{bias}]

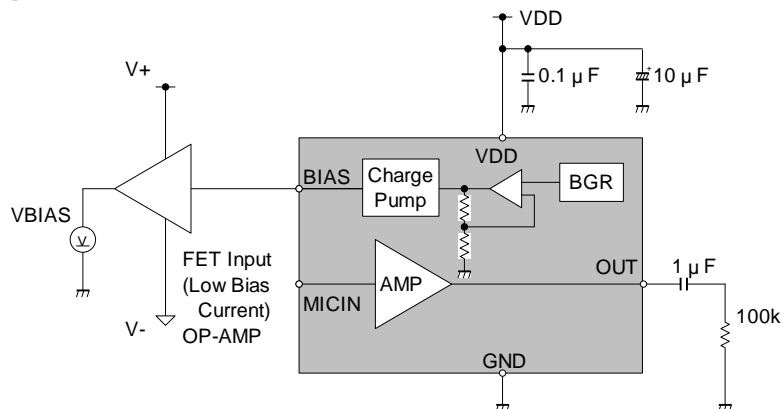

APPLICATION CIRCUIT

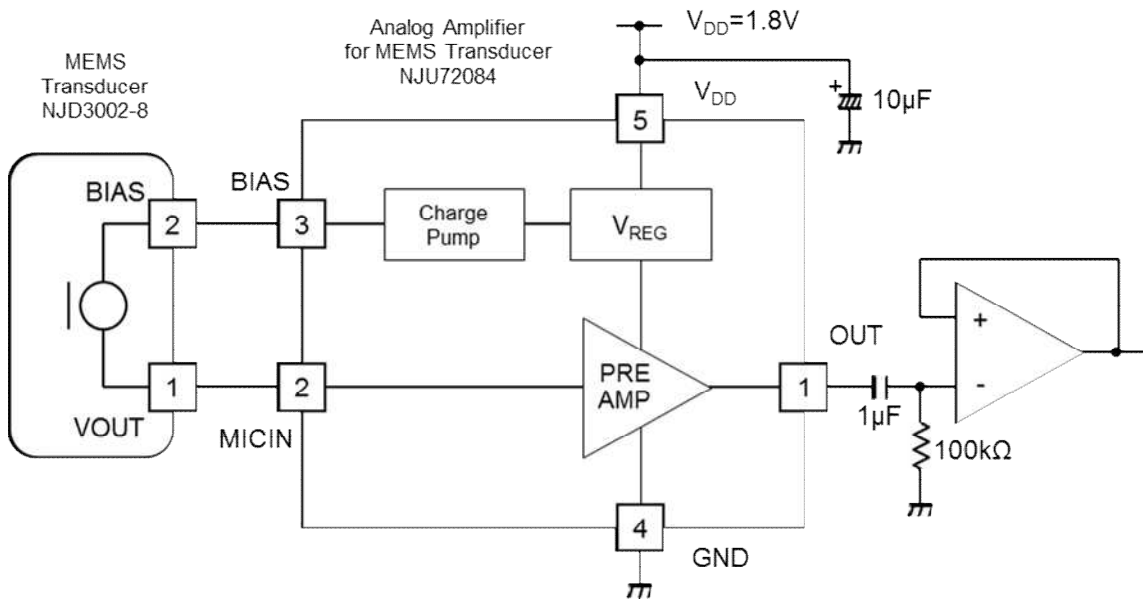

■CHIP OUTLINE

◆CHIP SIZE : 0.595mm x 0.780 mm

◆CHIP THICKNESS : 200 μm

◆PAD DIMENSION :

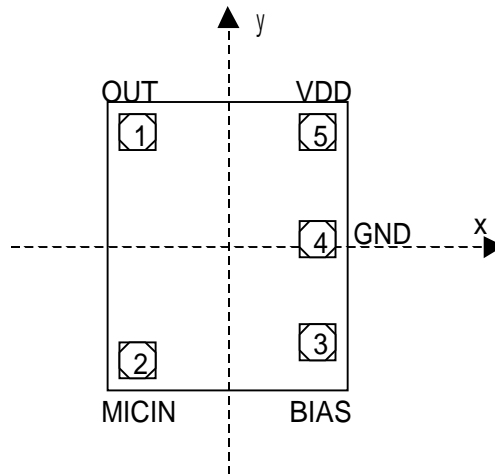

PIN NO.	SYMBOL	FUNCTION	X	UNIT	Y	UNIT
1	OUT	Output	-185	μm	+277.5	μm
2	MICIN	Microphone input	-185	μm	-277.5	μm
3	BIAS	Bias Voltage Output	+184.9	μm	-150.25	μm
4	GND	Ground	+184.9	μm	+27.8	μm
5	VDD	Power Supply	+184.9	μm	+277.5	μm

[CAUTION]
 The specifications on this databook are only given for information , without any guarantee as regards either mistakes or omissions. The application circuits in this databook are described only to show representative usages of the product and not intended for the guarantee or permission of any right including the industrial rights.