

## Low Dropout Voltage Regulator with Reset

### ■ GENERAL DISCRIPTION

The NJU7271 is a low drop out voltage regulator with output-monitor reset function. Advanced CMOS technology achieves ultra low current consumption and high accuracy.

It delivers up to 5V/100mA output power with the maximum input voltage of 9V.

The NJU7270 is suitable for MPU applications.

### ■ PACKAGE OUTLINE

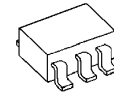

NJU7271F

### ■ FEATURES

- Ultra Low Quiescent Current  $I_q = 3.0\mu\text{A typ. (I}_o = 0\text{mA)}$
- Output Voltage Accuracy  $V_o = \pm 1.0\%$
- Reset Voltage Accuracy  $V_{RT} = \pm 1.0\%$
- Output Voltage Monitor type
- Output Current  $I_o(\text{max.}) = 100\text{mA}$
- Output capacitor with 0.1 $\mu\text{F}$  ceramic capacitor
- Nch Open Drain Output
- Internal Short Circuit Current Limit
- CMOS Technology
- Package Outline SOT-23-5

### ■ PIN CONFIGURATION

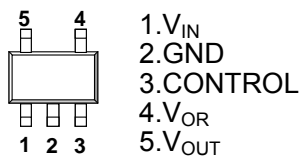

NJU7271F

### ■ EQUIVALENT CIRCUIT

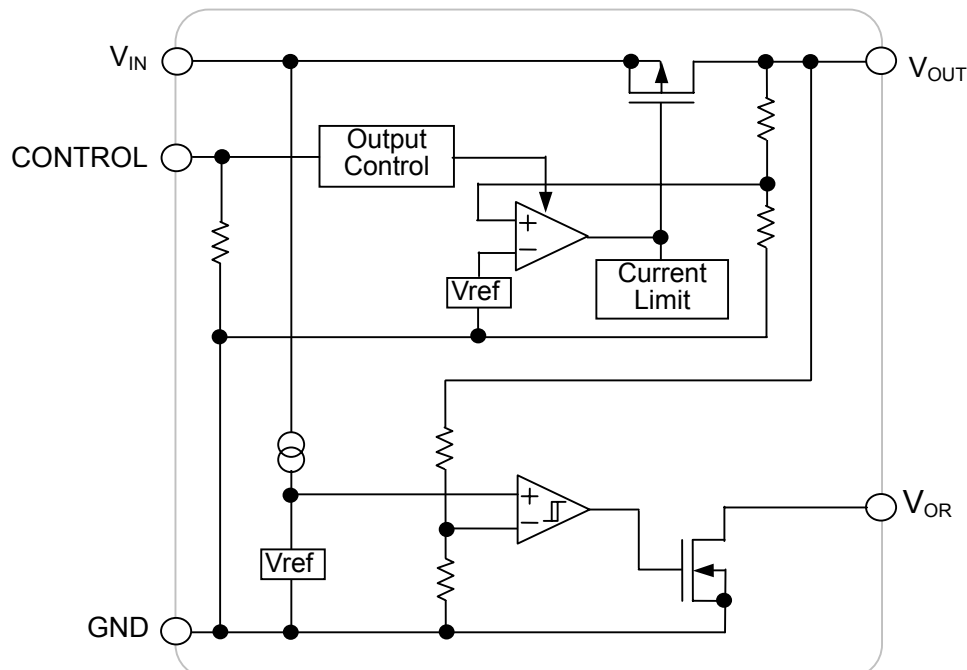

## ■ OUTPUT VOLTAGE/ DETECTION VOLTAGE

Device Name	Output Voltage	Detection Voltage
NJU7271F1813A	1.8V	1.3V
NJU7271F3328A	3.3V	2.8V
NJU7271F0543A	5.0V	4.3V

Output voltage options available : 1.8 ~ 5.0V (0.1V step)

Detection voltage options available : 1.3 ~ 4.5V (0.1V step)

## ■ ABSOLUTE MAXIMUM RATINGS

(Ta=25°C)

PARAMETER	SYMBOL	RATINGS	UNIT
Input Voltage	$V_{IN}$	+11	V
Control Voltage	$V_{CONT}$	+11(*1)	V
$V_{OR}$ Pin Output Voltage	$V_{OR}$	$V_{SS} - 0.3 \sim +11$	V
$V_{OR}$ Pin Output Current	$I_{OR}$	50	mA
Power Dissipation	$P_D$	200(*2) 350(*3)	mW
Operating Temperature	$T_{opr}$	-40 ~ +85	°C
Storage Temperature	$T_{stg}$	-40 ~ +125	°C

(\*1): Device itself

(\*2): Mounted on glass epoxy board based on EIA/JEDEC. (114.3x76.2x1.6mm: 2Layers)

## ■ ELECTRICAL CHARACTERISTICS ( $V_{IN}=V_O+1$ , $C_{IN}=0.1\mu F$ , $C_O=0.1\mu F$ , $T_a=25^\circ C$ )

PARAMETER	SYMBOL	TEST CONDITION	MIN.	TYP.	MAX.	UNIT	
General Characteristics							
Quiescent Current	$I_Q$	$V_{CONT}=V_{IN}$ , $I_O=0mA$	-	3.0	7.6	$\mu A$	
Quiescent Current at Control OFF	$I_{Q(OFF)}$	$V_{CONT}=0V$ , $I_O=0mA$	-	0.1	1.0	$\mu A$	
Regulator Block							
Output Voltage	$V_O$	$I_O=30mA$	-1.0%	-	+1.0%	V	
Output Current	$I_O$	$V_O - 0.3V$	100	-	-	mA	
Line Regulation	$\Delta V_O/\Delta V_{IN}$	$V_{IN}=V_O+1V \sim V_O+6V(3.0 > V_O)$ $V_{IN}=V_O+1V \sim 9.0V(3.0 \leq V_O)$ $I_O=30mA$	-	-	0.30	%/V	
Load Regulation	$\Delta V_O/\Delta I_O$	$I_O=0 \sim 100mA$	-	-	0.15	%/mA	
Output Voltage Temperature Coefficient	$\Delta V_O/\Delta T_a$	$T_a=0 \sim 85^\circ C$ , $I_O=10mA$	-	$\pm 100$	-	ppm/°C	
Control Voltage for ON-State	$V_{CONT(ON)}$		1.6	-	$V_{IN}$	V	
Control Voltage for OFF-State	$V_{CONT(OFF)}$		0	-	0.3	V	
Pull-down Resistance	$R_{CONT}$		2.0	5	10	M $\Omega$	
Short Circuit Limit	$I_{LIM}$	$V_O=0V$	-	25	-	mA	
Input Voltage	$V_{IN}$		-	-	9	V	
Dropout Voltage	$\Delta V_{I-O}$	$I_O=40mA$	$1.5V \leq V_O \leq 2.0V$	-	0.19	0.60	V
			$2.1V \leq V_O \leq 2.4V$	-	0.19	0.29	V
			$2.5V \leq V_O \leq 2.7V$	-	0.18	0.27	V
		$I_O=60mA$	$2.8V \leq V_O \leq 3.3V$	-	0.17	0.26	V
			$3.4V \leq V_O \leq 5.0V$	-	0.16	0.24	V
			$5.1V \leq V_O \leq 6.0V$	-	0.15	0.22	V

PARAMETER	SYMBOL	TEST CONDITION	MIN.	TYP.	MAX.	UNIT	
Reset Block							
Detection Voltage	$V_{DET}$		-1.0%	-	+1.0%	V	
Hysteresis Voltage	$V_{HYS}$		$V_{DET} \times 0.03$	$V_{DET} \times 0.05$	$V_{DET} \times 0.08$	V	
$V_{OR}$ Pin Output Current	$I_{OR}$	Nch, $V_{DS}=0.5V$ $V_{CONT}=0V$	$V_{IN}=1.2V$	0.75	2.0	-	mA
			$V_{IN}=2.4V$ ( $V_{DET} \geq 2.7V$ Version)	4.5	7.0	-	mA
Output Leak Current	$I_{LEAK}$	$V_{IN}=V_{OR}=V_{CONT}=9V$	-	-	0.1	$\mu A$	
Detection Voltage	$\Delta V_{DET}/\Delta Ta$	$Ta=0 \sim 85^{\circ}C$	-	$\pm 100$	-	ppm/ $^{\circ}C$	
Operating Voltage(*4)	$V_{OPL}$	$R_L=100k\Omega$	-	-	0.8	V	

(\*3): The value condition that  $V_{OR}$  become 10% or less of  $V_{IN}$ .

■ TIMING CHART

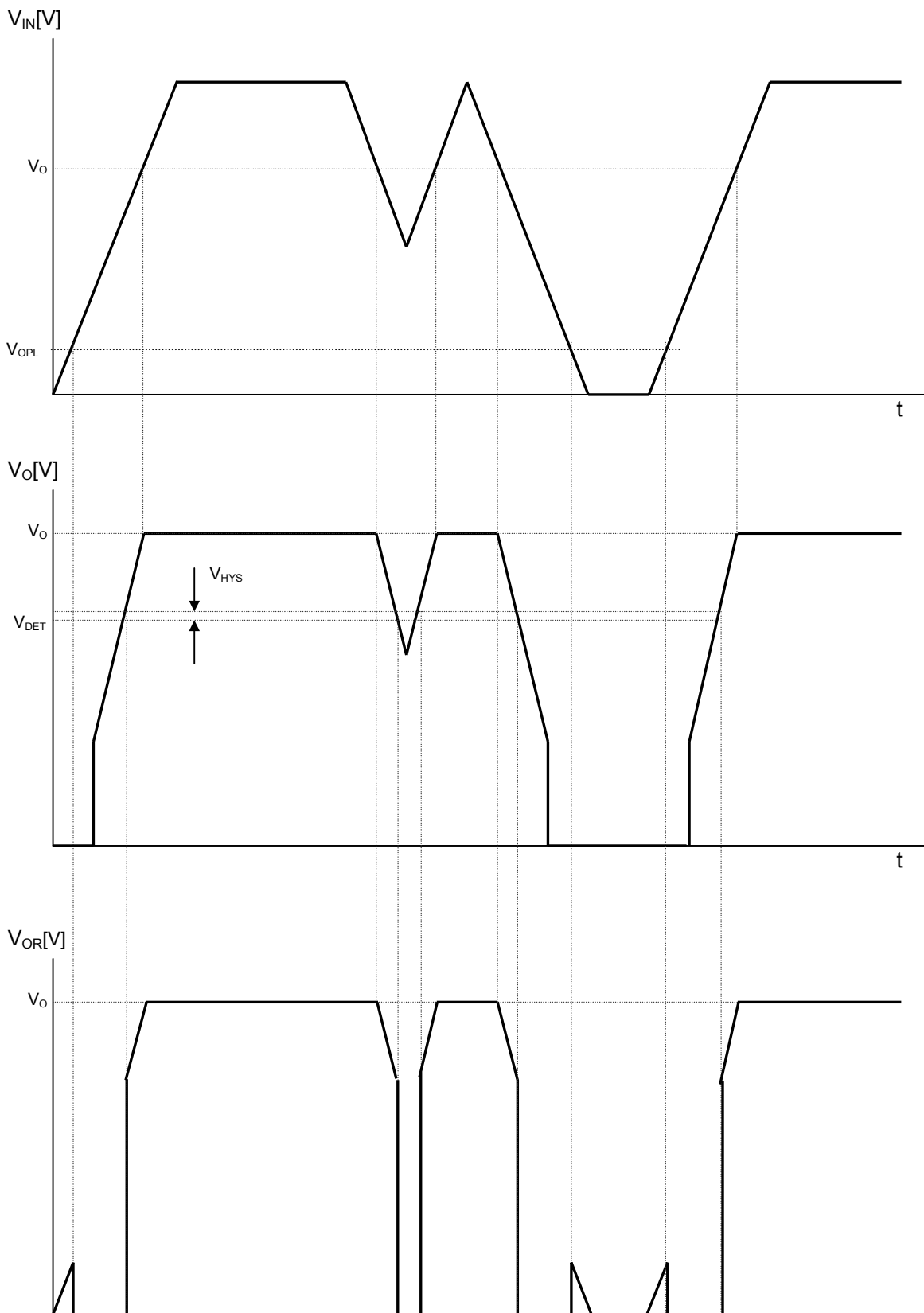

\*  $V_{OR}$  is the case where a pull-up is carried out to  $V_{IN}$  through resistance.

■ TEST CIRCUIT

① COMMON TEST CIRCUIT

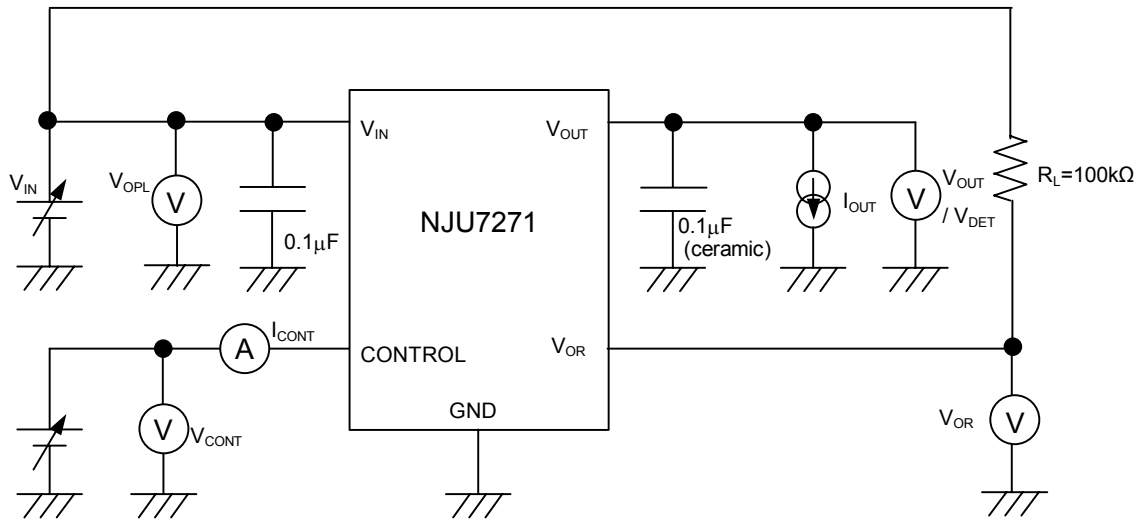

② OUTPUT CURRENT/OUTPUT LEAK CURRENT TEST CIRCUIT

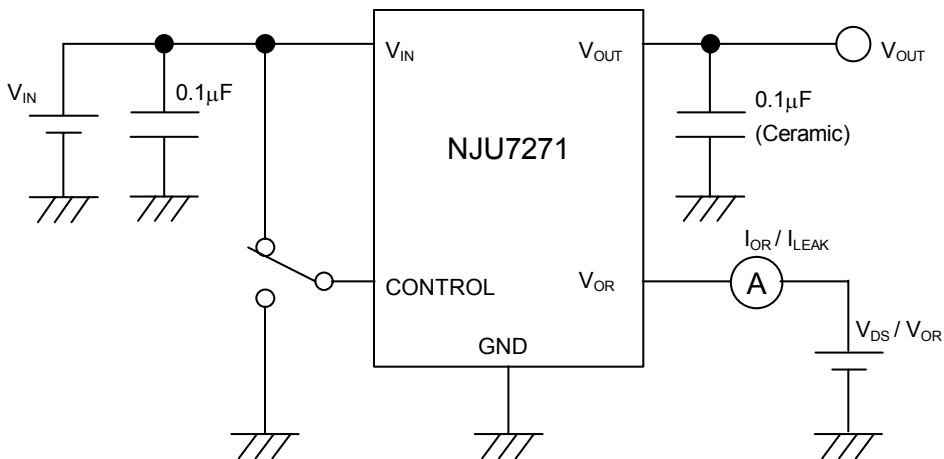

③ QUIESCENT CURRENT TEST CIRCUIT

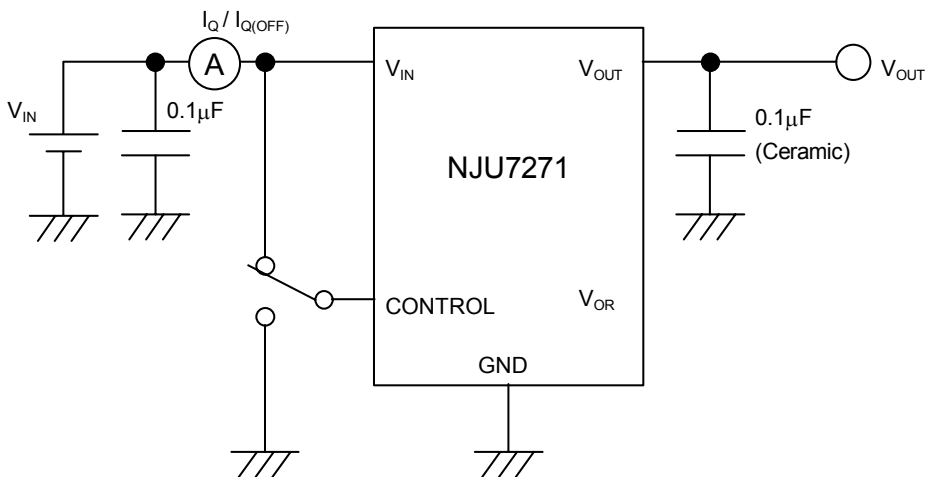

■ TYPICAL APPLICATION

① In case that ON/OFF Control is not required:

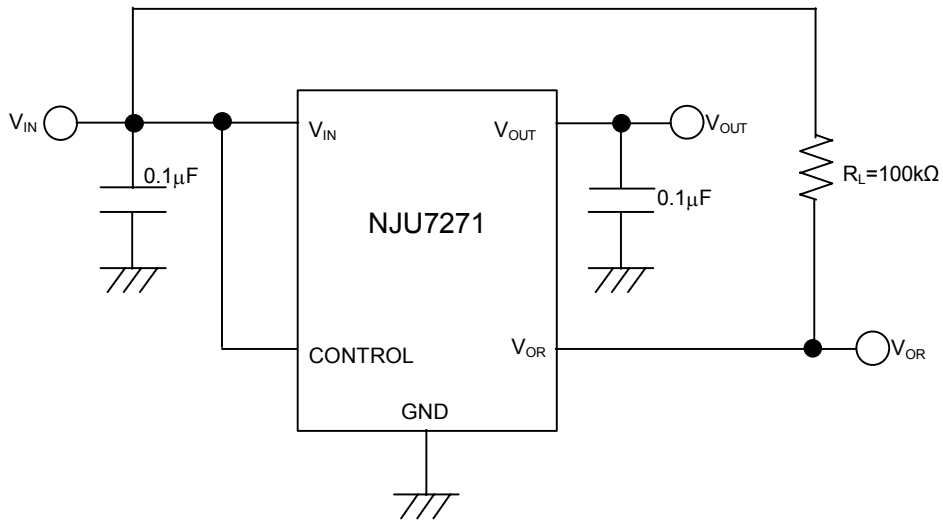

Connect control terminal to V<sub>IN</sub> terminal.

② In use of ON/OFF Control:

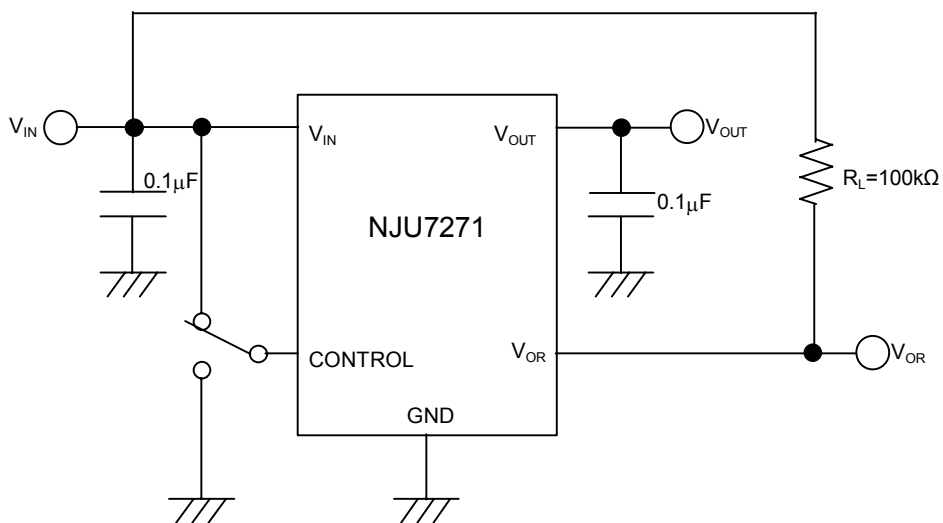

State of control terminal:

- "H" → output is enabled.
- "L" or "open" → output is disabled.

**\*Input Capacitance  $C_{IN}$**

Input Capacitance  $C_{IN}$  is required to prevent oscillation and reduce power supply ripple for applications with high power supply impedance or a long power supply line.

Use the  $C_{IN}$  value of 0.1  $\mu$ F greater to avoid the problem.

$C_{IN}$  should connect between GND and  $V_{IN}$  as short as possible.

**\*Output Capacitance  $C_o$**

Output capacitor ( $C_o$ ) is required for a phase compensation of the internal error amplifier. The capacitance and the equivalent series resistance (ESR) influence stability of the regulator.

If use a smaller  $C_o$ , it may cause excess output noise or oscillation of the regulator due to lack of the phase compensation. Therefore, use  $C_o$  with the recommended capacitance or greater value and connect between  $V_o$  terminal and GND terminal with minimal wiring.

The recommended capacitance depends on the output voltage. Low voltage regulator requires greater value of the  $C_o$ . Thus, check the recommended capacitance for each output voltage.

Use of a greater  $C_o$  reduces output noise and ripple output, and also improves transient response of the output voltage against rapid load change.

This product is designed to work with any capacitor including a low ESR capacitor for the  $C_o$ ; however, refer "Equivalent Series Resistance vs. Output Current" and choose suitable capacitor.

**■ POWER DISSIPATION vs. AMBIENT TEMPERATURE**

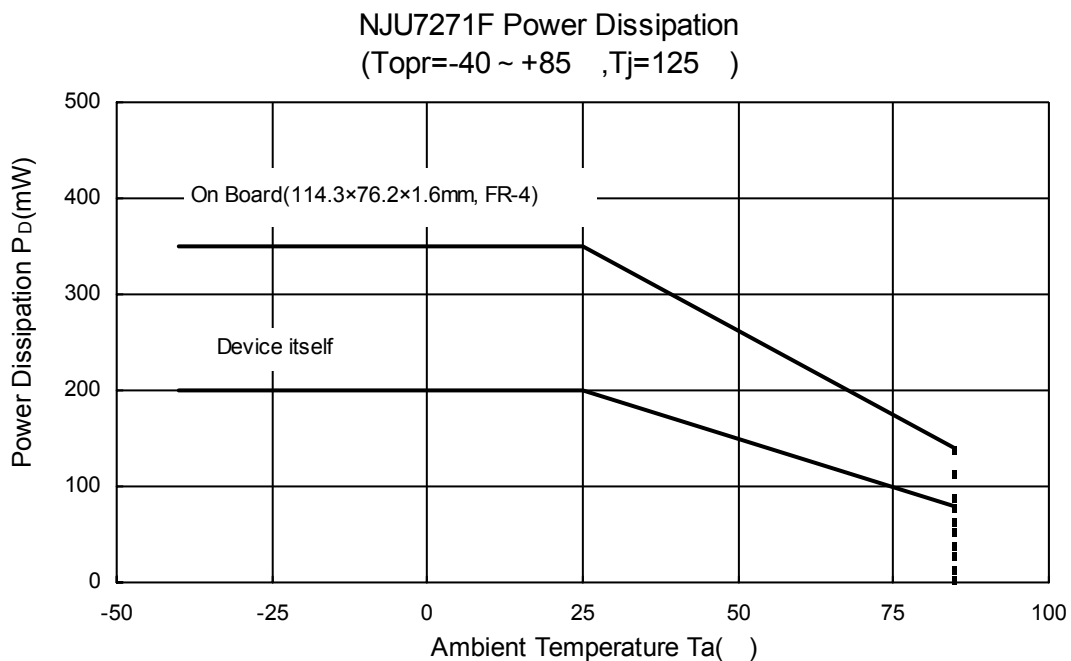

■ TYPICAL CHARACTERISTICS (LDO BLOCK)

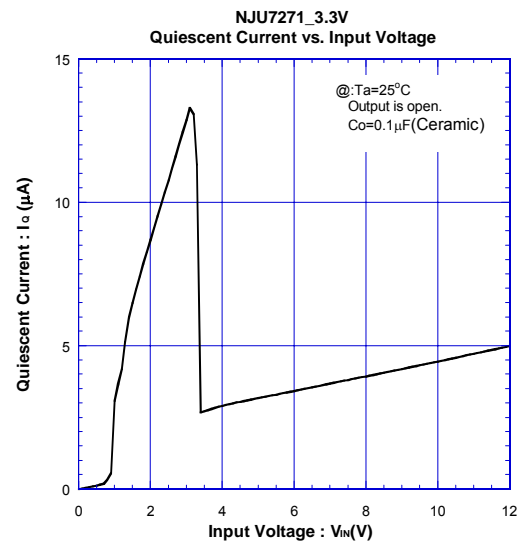
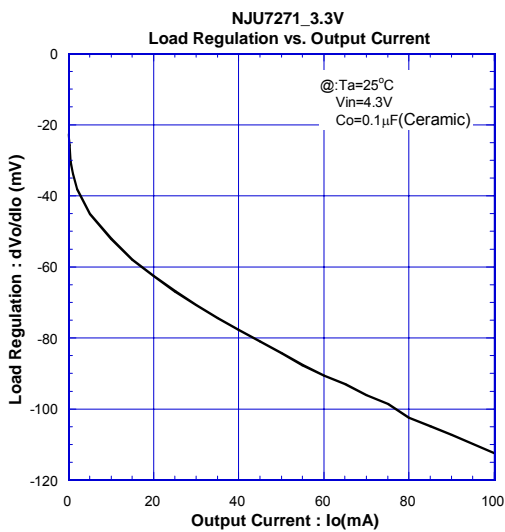
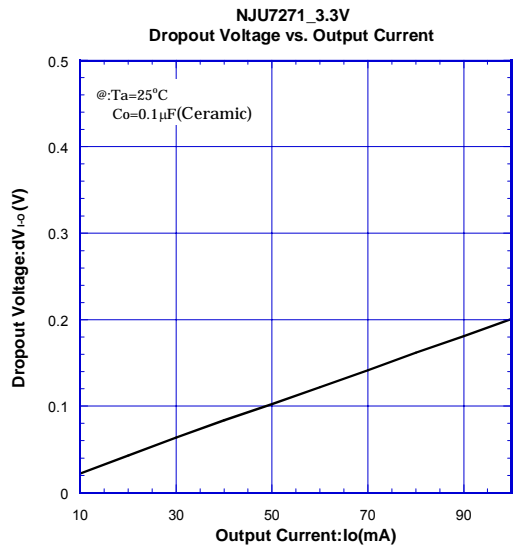
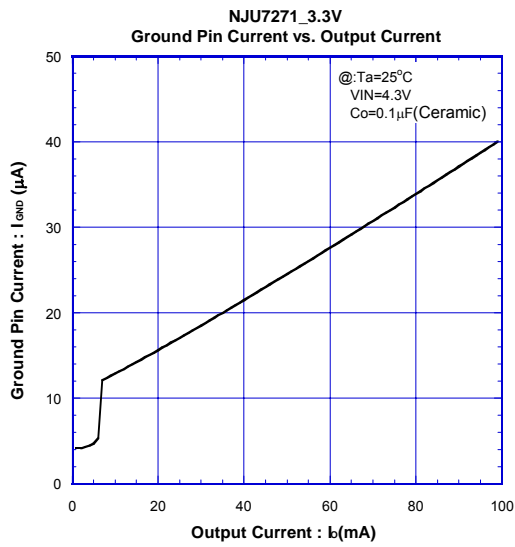
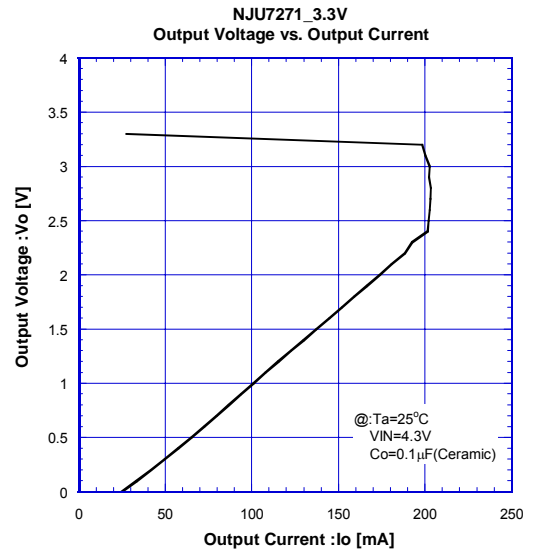
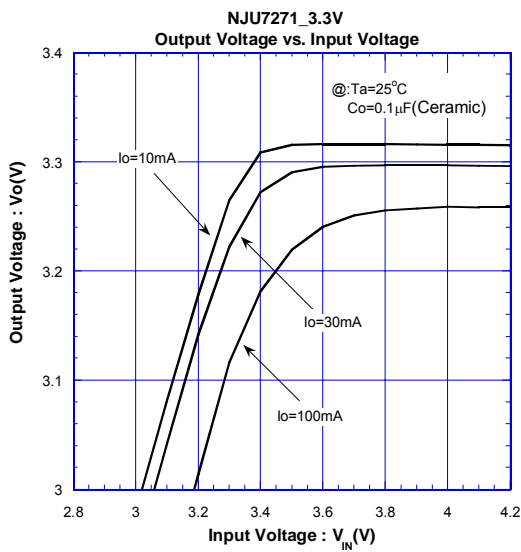



■ TYPICAL CHARACTERISTICS (LDO BLOCK)

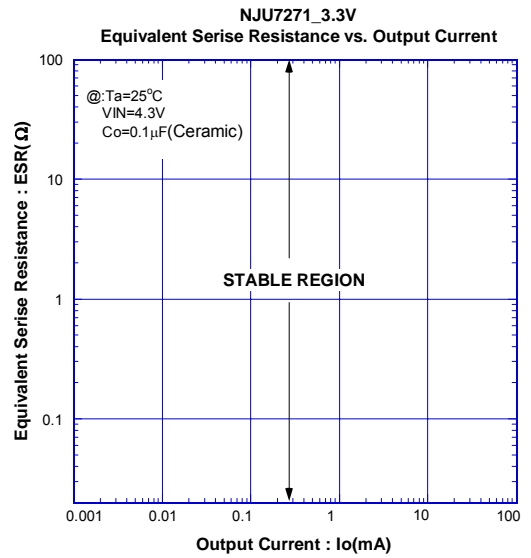
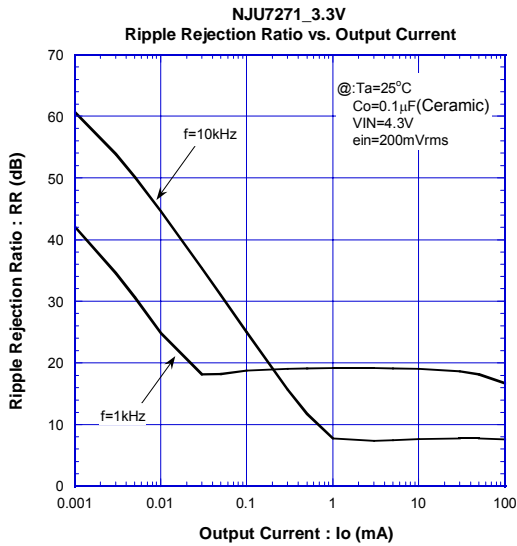
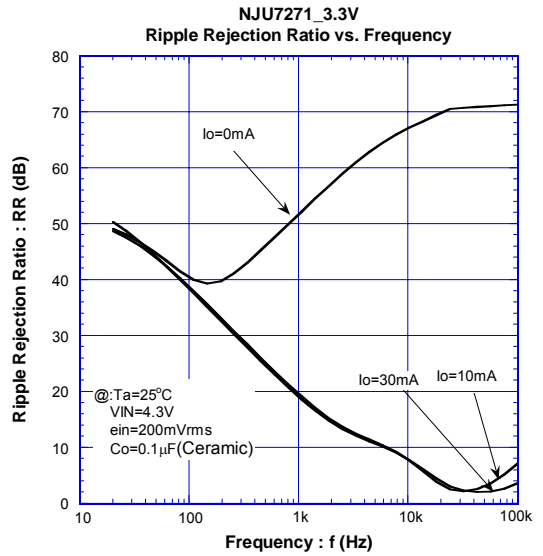
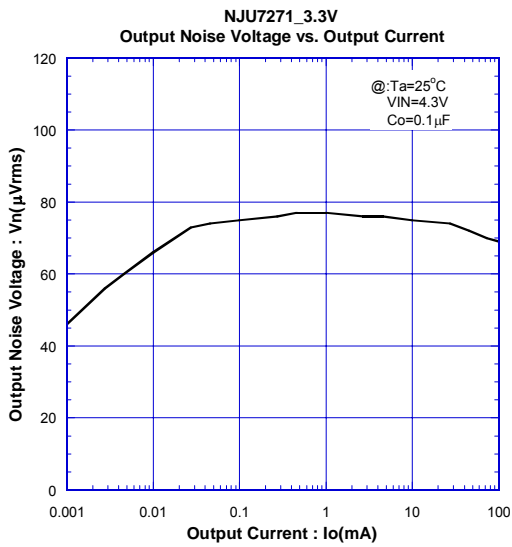

## ■ TYPICAL CHARACTERISTICS (LDO BLOCK)

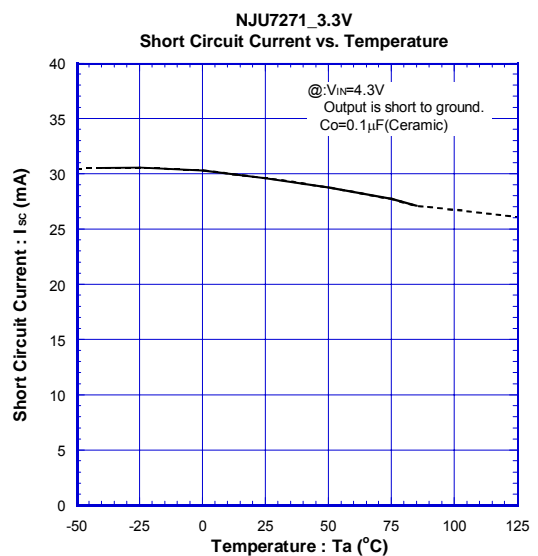
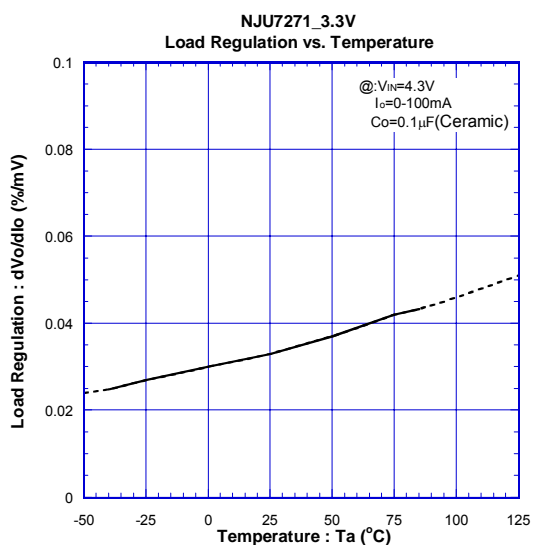
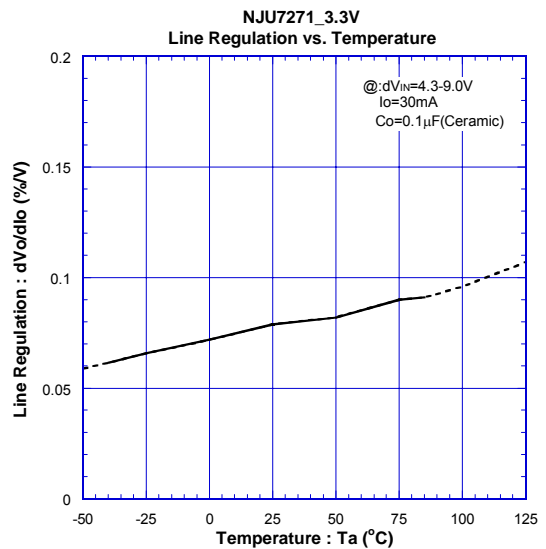
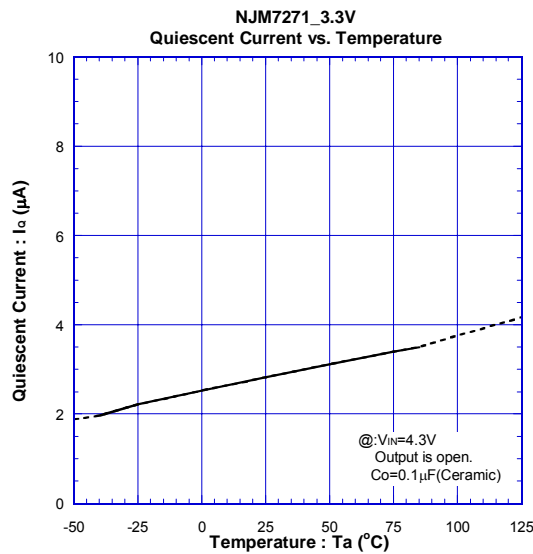
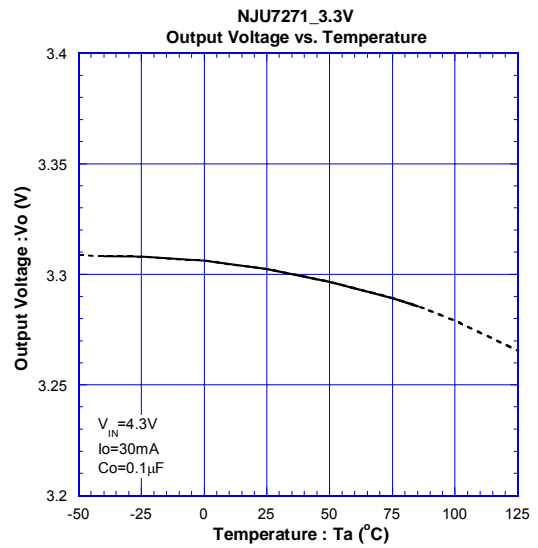
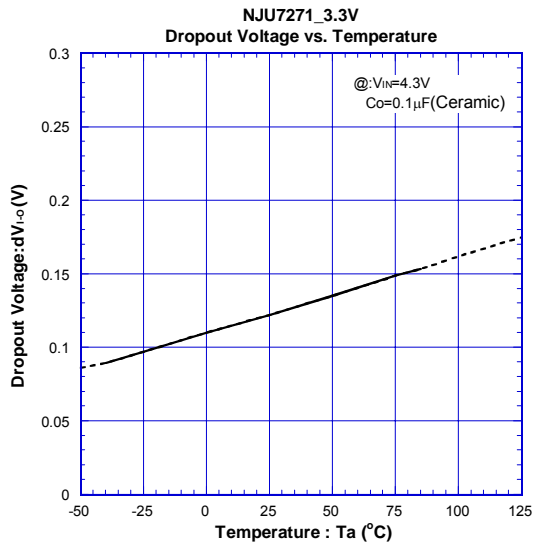

■ TYPICAL CHARACTERISTICS (RESET BLOCK)

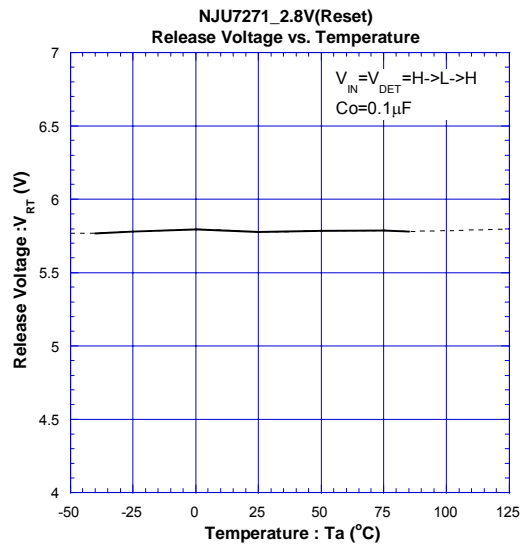
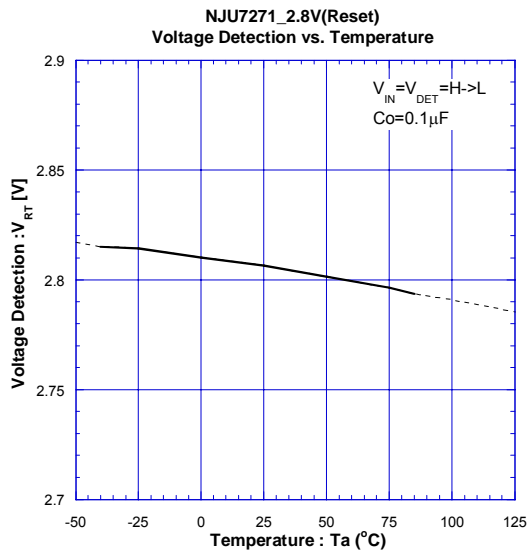

[CAUTION]  
 The specifications on this databook are only given for information, without any guarantee as regards either mistakes or omissions. The application circuits in this databook are described only to show representative usages of the product and not intended for the guarantee or permission of any right including the industrial rights.