

## Single-phase DC Brushless Motor Driver IC

### ■ GENERAL DESCRIPTION

The NJU7367 is a single-phase motor driver IC. It features lock detect, FG output and thermal shutdown circuit functions.

The motor rotational speed is controlled by PWM input pulse.

The NJU7367 is available in a small and thin 8-lead MSOP(TVSP) package.

### ■ PACKAGE OUTLINE

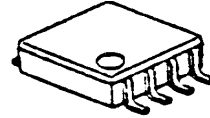

NJU7367RB1  
(MSOP8 (TVSP8))

### ■ FEATURES

- Supply Voltage  $V_{DD}=2.0$  to  $5.5V$
- Low Quiescent Current  $I_{DD}=1.0mA$  typ.
- Maximum Output Voltage  $V_{OH}=4.8V$  typ. @  $I_o=+350mA$ ,  $V_{OL}=0.2V$  typ. @  $I_o=-350mA$
- Input Offset Voltage  $V_{IO}=\pm 10mV$
- Direct PWM Input
- Lock Detect
- FG Output
- Thermal Shutdown Circuit
- CMOS Technology
- Package Outline MSOP8 (TVSP8)\*

\*MEET JEDEC MO-187-DA/THIN TYPE

### ■ BLOCK DIAGRAM

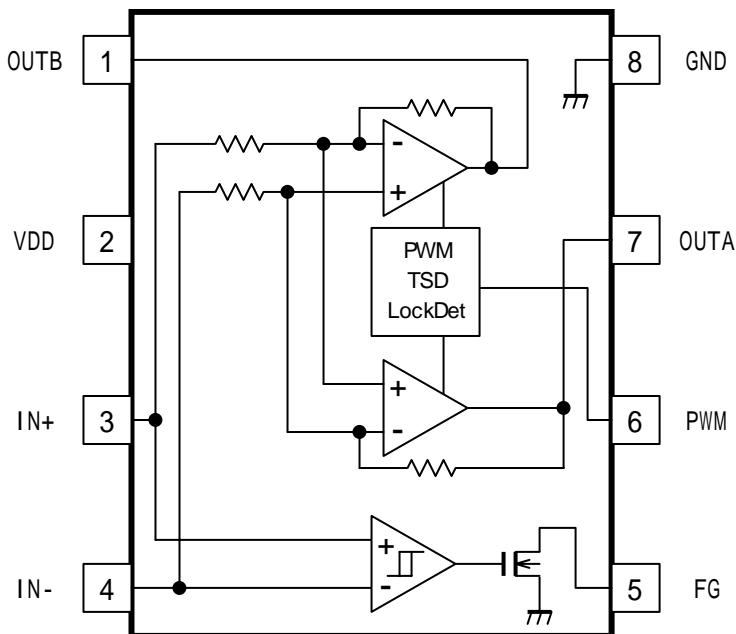

### ■ PIN FUNCTION

PIN No.	PIN NAME
1	OUTB
2	VDD
3	IN+
4	IN-
5	FG
6	PWM
7	OUTA
8	GND

# NJU7367

## ■ ABSOLUTE MAXIMUM RATINGS

(Ta=25°C)

PARAMETER	SYMBOL	RATINGS		UNIT
Supply Voltage	V <sub>DD</sub>	+7.0		V
Input Voltage	V <sub>ID</sub>	-0.3 to V <sub>DD</sub>		V
PWM Input Voltage	V <sub>PWM</sub>	-0.3 to V <sub>DD</sub>		V
Output Current (Peak)	I <sub>OPEAK</sub>	700		mA
FG Output Current	I <sub>FG</sub>	10		mA
FG Output Voltage	V <sub>FG</sub>	+7.0		V
Power Dissipation	P <sub>D</sub>	Device itself	400	mW
		Mounted on 2Layer Board (*1)	510	
Operating Temperature	Topr	-40 to +85		°C
Junction Temperature	Tjmax	150		°C
Storage Temperature	Tstg	-50 to +150		°C

(\*1): Mounted on glass epoxy board based on EIA/JEDEC. (76.2 × 114.3 × 1.6mm: 2-Layers FR-4)

## ■ RECOMMENDED OPERATING CONDITIONS

(Ta=25°C)

PARAMETER	SYMBOL	TEST CONDITION	MIN.	TYP.	MAX.	UNIT
Supply Voltage	V <sub>DD</sub>	-	2.0	5.0	5.5	V

## ■ ELECTRICAL CHARACTERISTICS

( $V_{DD}=5V$ ,  $T_a=25^{\circ}C$ )

PARAMETER	SYMBOL	TEST CONDITION	MIN.	TYP.	MAX.	UNIT
<b>■ GENERAL</b>						
Quiescent Current	$I_{DD}$	$I_{N+}=3.9V$ , $I_{N-}=0.4V$	-	1.0	1.5	mA
Thermal Shutdown Operating Temperature	$T_{TSD}$	-	-	170	-	$^{\circ}C$
Thermal Shutdown Hysteresis	$T_{HYS}$	-	-	20	-	$^{\circ}C$
<b>■ HALL AMP BLOCK</b>						
Input Offset Voltage	$V_{IO}$	-	-10	-	10	mV
Common Mode Input Voltage Range	$V_{ICM}$	-	0.4	-	3.9	V
Close-loop Gain	$A_V$	-	-	44.5	-	dB
<b>■ OUTPUT BLOCK</b>						
Output Voltage	$V_{OH}$	$I_{O+}=+350mA$	4.7	4.8	-	V
	$V_{OL}$	$I_{O-}=-350mA$	-	0.2	0.3	V
FG L Output Voltage	$V_{FG}$	$I_{FG}=5mA$	-	-	0.2	V
FG H Leak Current	$I_{FG-LEAK}$	$V_{FG}=5V$	-	-	1.0	$\mu A$
<b>■ PWM INPUT BLOCK</b>						
PWM Input Frequency	$f_{PWM}$	-	2	-	50	kHz
Pullup resistance	$R_{PWM}$	-	-	200	-	$k\Omega$
Input H Level Voltage1	$V_{IHP}$	-	2.4	-	5	V
Input L Level Voltage1	$V_{ILP}$	-	0	-	1.4	V
Input H Level Voltage2	$V_{IHP}$	$V_{DD}=2V$	1.1	-	2	V
Input L Level Voltage2	$V_{ILP}$	$V_{DD}=2V$	0	-	0.5	V
<b>■ LOCK DETECT BLOCK</b>						
Lock Detect ON Time	$t_{ON}$	-	-	0.5	-	s
Lock Detect OFF Time	$t_{OFF}$	-	-	5.0	-	s
Lock Detect Ratio	$t_{RATIO}$	-	-	1:10	-	-

# NJU7367

## TRUTH TABLE

No.	IN+	IN -	PWM	TSD	LD	OUTA	OUTB	FG
1	H	L	H	OFF	OFF	H	L	L
2	L	H	H	OFF	OFF	L	H	Z
3	H	L	L	OFF	OFF	L	L	L
4	L	H	L	OFF	OFF	L	L	Z
5	H	L	H	ON	OFF	L	L	L
6	L	H	H	ON	OFF	L	L	Z
7	H	L	L	ON	OFF	L	L	L
8	L	H	L	ON	OFF	L	L	Z
9	H	L	H	OFF	ON	L	L	L
10	L	H	H	OFF	ON	L	L	Z
11	H	L	L	OFF	ON	L	L	L
12	L	H	L	OFF	ON	L	L	Z
13	H	L	H	ON	ON	L	L	L
14	L	H	H	ON	ON	L	L	Z
15	H	L	L	ON	ON	L	L	L
16	L	H	L	ON	ON	L	L	Z

Z : High Impedance

## TIMING CHART at PWM

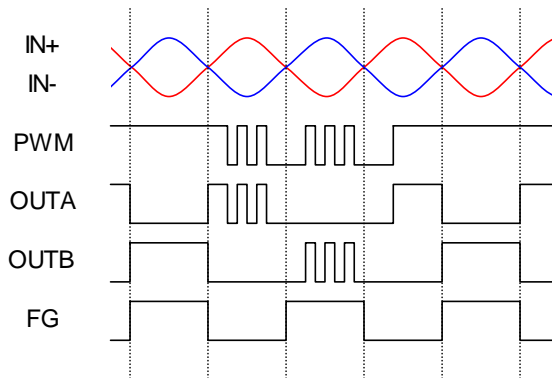

## TIMING CHART at LOCK DETECT

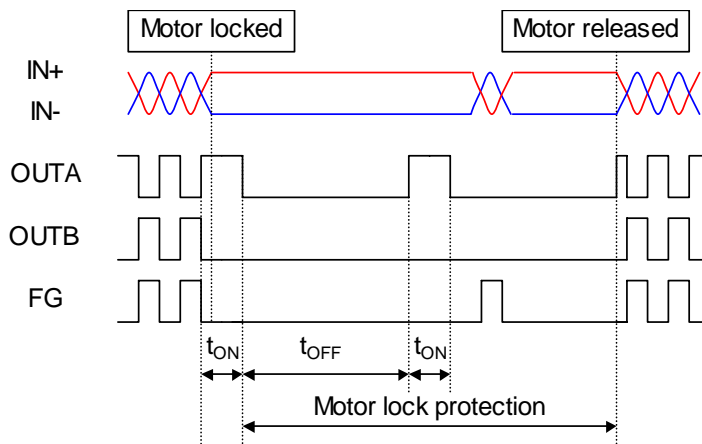

## QUICK START TIMING CHART

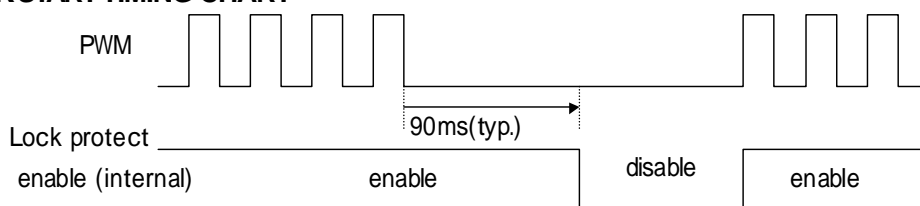

## ■ TYPICAL APPLICATION CIRCUIT

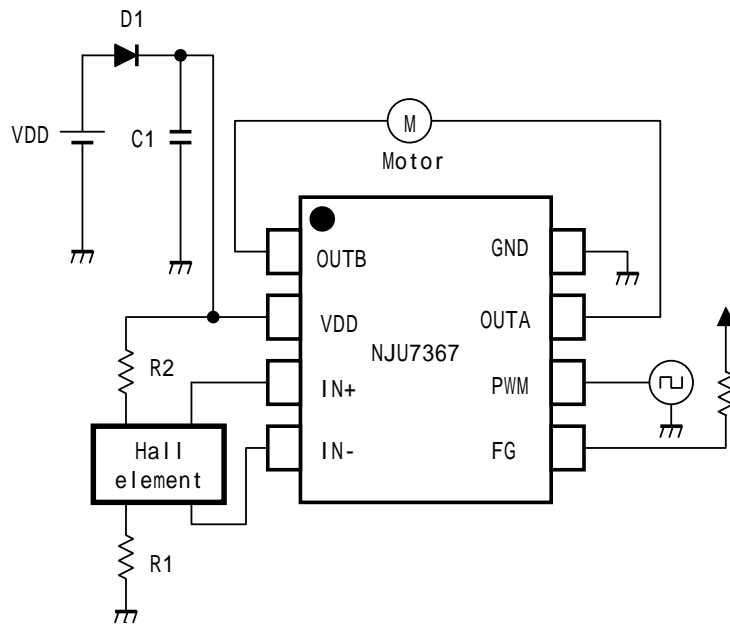

## ■ POWER DISSIPATION vs. AMBIENT TEMPERATURE

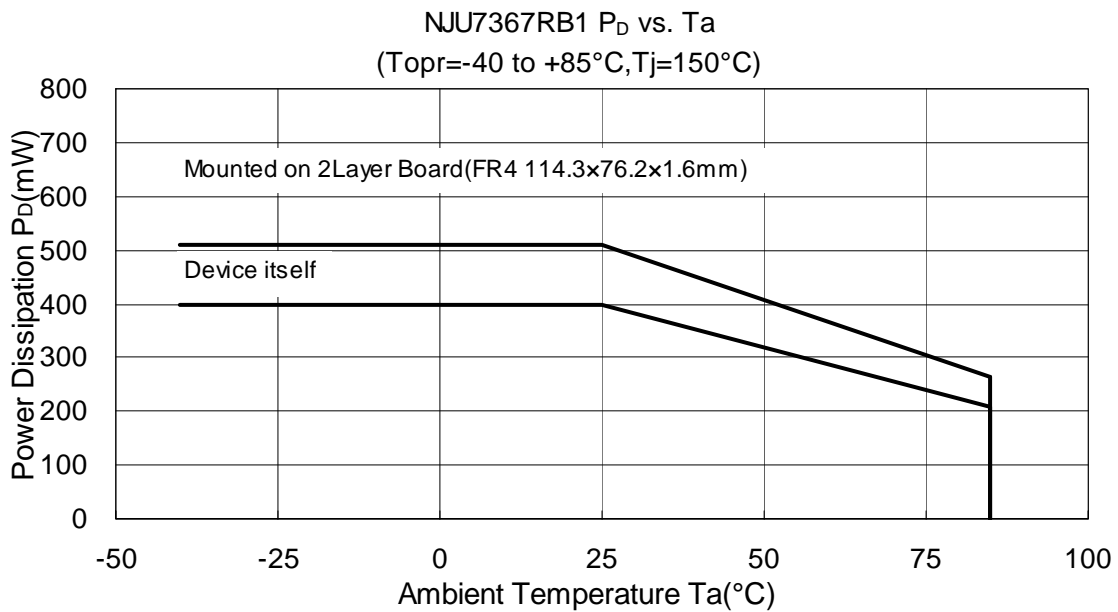

## TYPICAL CHARACTERISTICS

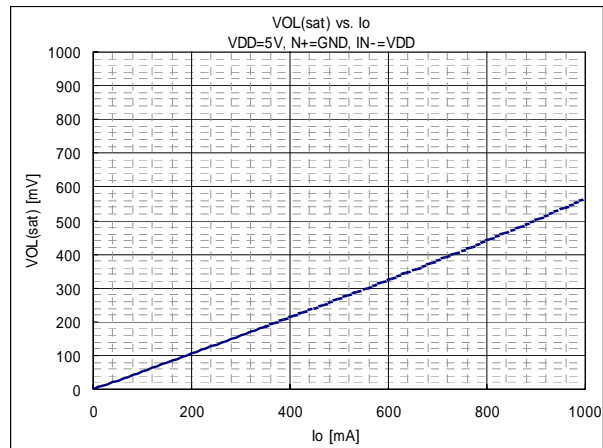
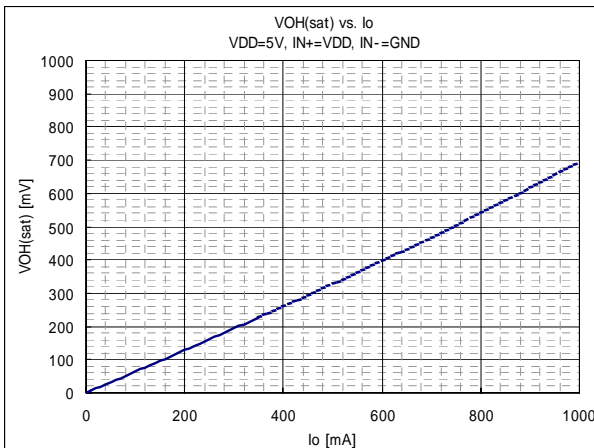
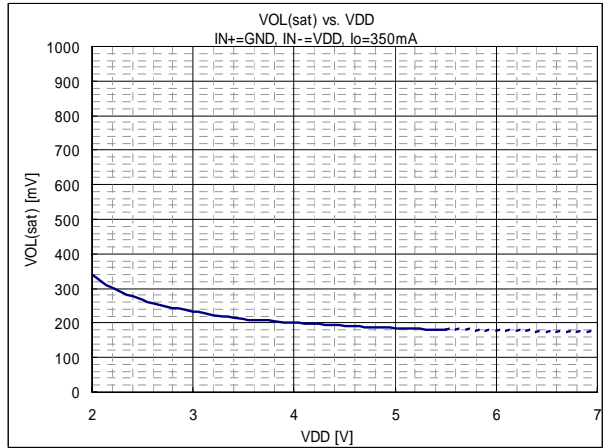
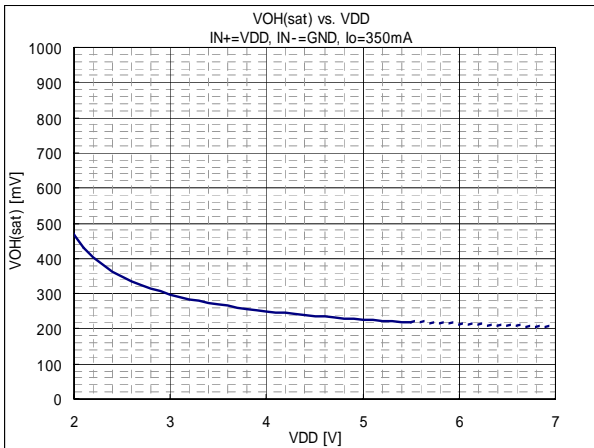
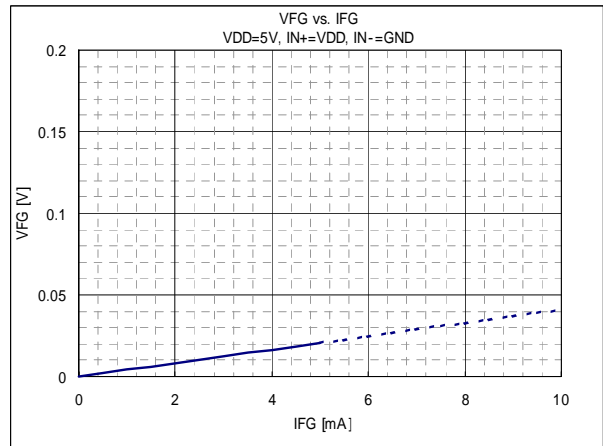
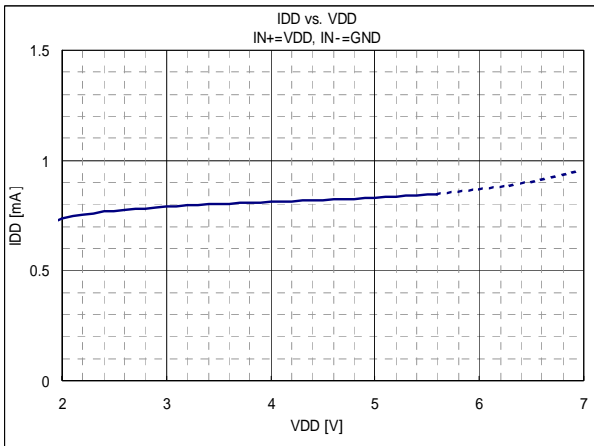

## TYPICAL CHARACTERISTICS

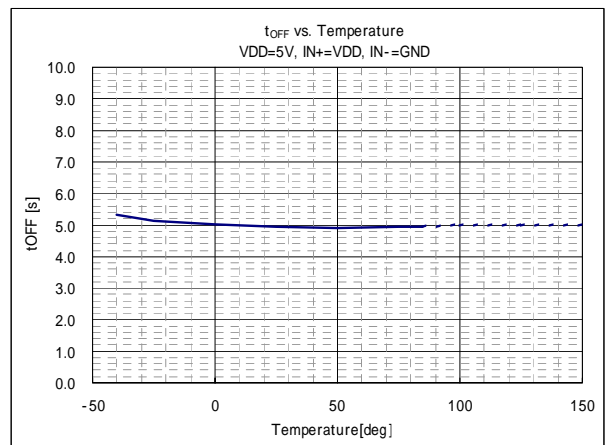
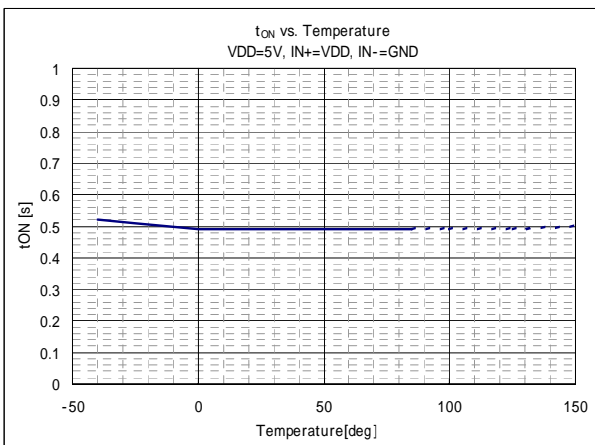
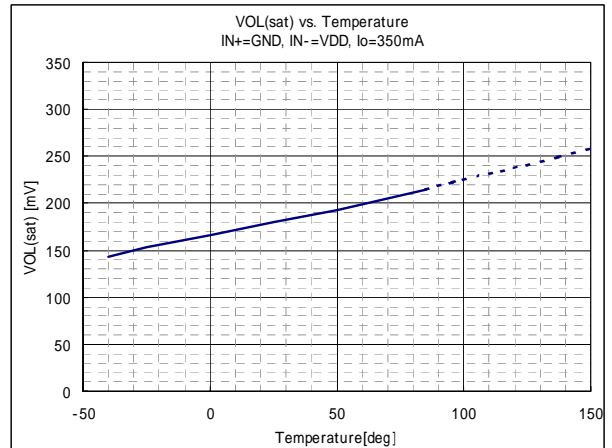
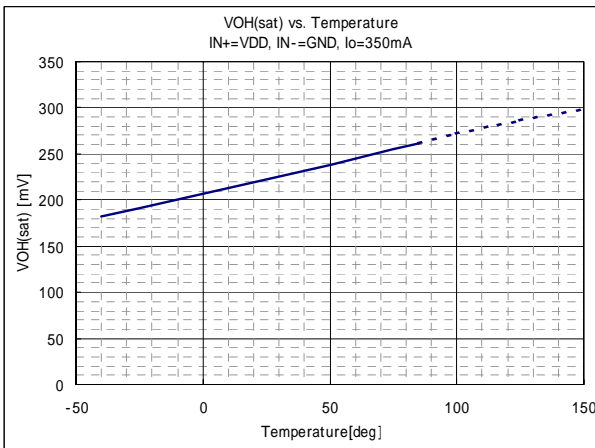
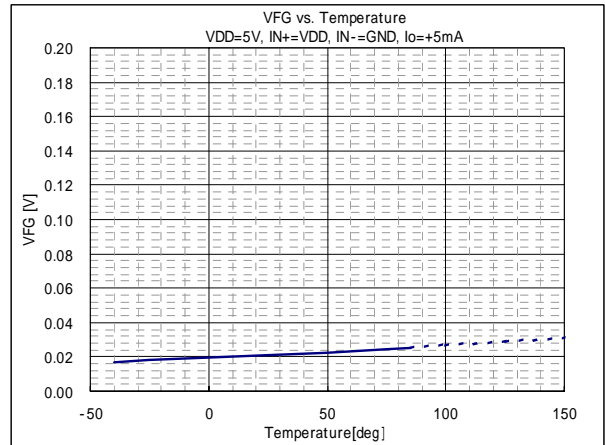
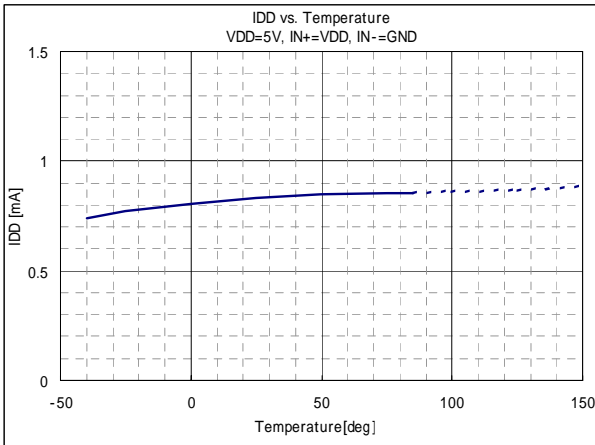

**[CAUTION]**  
The specifications on this databook are only given for information, without any guarantee as regards either mistakes or omissions. The application circuits in this databook are described only to show representative usages of the product and not intended for the guarantee or permission of any right including the industrial rights.