

## Single-phase DC Brushless Motor Driver IC

### FEATURES

- Supply Voltage  $V_{DD}=2.0$  to  $5.5V$
- Low Quiescent Current  $I_{DD}=1.0mA$  typ.
- Output Voltage  $V_{OH}=4.8V$  typ. ( $I_o=+350mA$ )  
 $V_{OL}=0.2V$  typ. ( $I_o=-350mA$ )
- Input Offset Voltage  $V_{IO}=\pm 10mV$  max.
- Closed-loop Gain  $A_v=49.8dB$  typ.
- Direct PWM Input
- Lock Protection Function (Auto Recovery)
- FG Output
- Start up Assist Function
- Quick Start Function
- Thermal Shutdown Function
- Operating Temperature  $T_{opr}=-40$  to  $105^\circ C$
- Package Outline MSOP8-Thin (TVSP8)\*

\*MEET JEDEC MO-187-DA/THIN TYPE

### GENERAL DESCRIPTION

The NJU7367B is a single-phase motor driver IC for small DC brushless motor.

It features Lock Protection, FG Output, Start up Assist, Quick Start and Thermal Shutdown function.

The motor rotational speed is controlled by PWM input signal.

High closed-loop gain and wide operating temperature range make NJU7367B suitable for a small fan motor in high temperature application such as car accessory.

### APPLICATION

Small 5V-FAN Motor

### TYPICAL APPLICATION

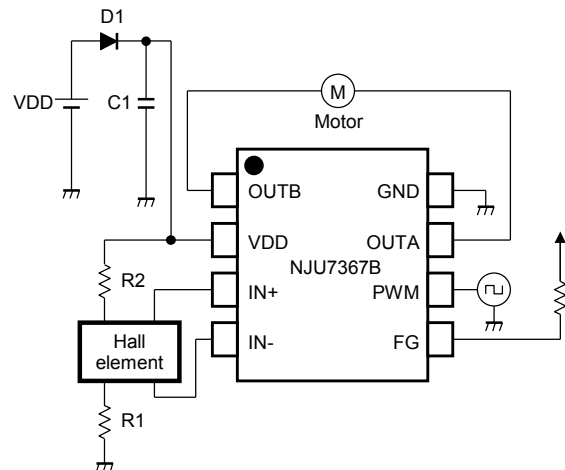

### BLOCK DIAGRAM

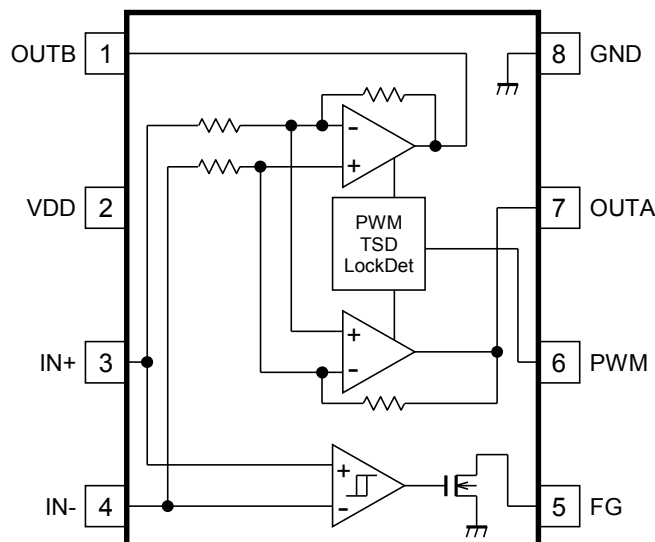

## ■PIN CONFIGURATION

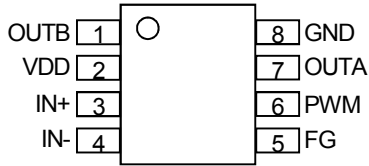

PIN NO.	SYMBOL	I/O	DESCRIPTION
1	OUTB	O	Output Pin B
2	VDD	-	Power Supply Pin
3	IN+	I	Input Pin +
4	IN-	I	Input Pin -
5	FG	O	FG Output Pin
6	PWM	I	PWM Input Pin
7	OUTA	O	Output Pin A
8	GND	-	Ground Pin

## ■PRODUCT NAME INFORMATION

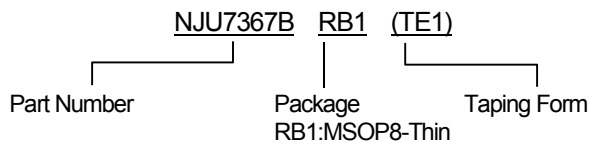

## ■ORDERING INFORMATION

PRODUCT NAME	PACKAGE OUTLINE	RoHS	HALOGEN-FREE	TERMINAL FINISH	MARKING	WEIGHT (mg)	MOQ(pcs)
NJU7367BRB1(TE1)	MSOP8-Thin	yes	yes	Sn2Bi	7367B	17.8	2,000

**■ABSOLUTE MAXIMUM RATINGS**

PARAMETER	SYMBOL	RATINGS	UNIT	NOTE
Supply Voltage	$V_{DD}$	+7.0	V	VDD Pin
Input Voltage	$V_{ID}$	-0.3 to $V_{DD}$	V	IN+, IN- Pin
PWM Input Voltage	$V_{PWM}$	-0.3 to +7.0	V	PWM Pin
Output Current (Peak)	$I_{OPEAK}$	1000	mA	OUTA, OUTB Pin
FG Output Current	$I_{FG}$	10	mA	FG Pin
FG Output Voltage	$V_{FG}$	+7.0	V	FG Pin
Power Dissipation( $T_a=25^\circ\text{C}$ ) MSOP-Thin	$P_D$	400 <sup>(1)</sup> 510 <sup>(2)</sup>	mW	
Junction Temperature Range	$T_j$	-40 to +150	$^\circ\text{C}$	
Operating Temperature Range	$T_{opr}$	-40 to +105	$^\circ\text{C}$	
Storage Temperature Range	$T_{stg}$	-50 to +150	$^\circ\text{C}$	

(1): Device itself

(2): Mounted on glass epoxy board. (76.2×114.3×1.6mm: based on EIA/JEDEC standard, 2Layers FR-4)

**■RECOMMENDED OPERATING CONDITIONS**

PARAMETER	SYMBOL	RATINGS	UNIT
Supply Voltage	$V_{DD}$	2.0 to 5.5	V

**■ELECTRICAL CHARACTERISTICS**

(Unless otherwise noted,  $V_{DD}=5\text{V}$ ,  $T_a=25^\circ\text{C}$ )

PARAMETER	SYMBOL	TEST CONDITION	MIN.	TYP.	MAX.	UNIT
-----------	--------	----------------	------	------	------	------

**GENERAL**

Quiescent Current	$I_{DD}$	IN+=3.9V, IN-=0.4V	-	1.0	1.5	mA
Thermal Shutdown Operating Temperature	$T_{TSD}$		-	170	-	$^\circ\text{C}$
Thermal Shutdown Hysteresis	$T_{HYS}$		-	20	-	$^\circ\text{C}$

**HALL AMP BLOCK**

Input Offset Voltage	$V_{IO}$		-10	-	10	mV
Common Mode Input Voltage Range	$V_{ICM}$		0.4	-	3.9	V
Closed-loop Gain	$A_V$		-	49.8	-	dB

**OUTPUT BLOCK**

Output Voltage	$V_{OH}$	$I_O=+350\text{mA}$	4.7	4.8	-	V
	$V_{OL}$	$I_O=-350\text{mA}$	-	0.2	0.3	V
FG L Output Voltage	$V_{FG}$	$I_{FG}=5\text{mA}$	-	-	0.2	V
FG Leak Current	$I_{FG-LEAK}$	$V_{FG}=5\text{V}$	-	-	1.0	$\mu\text{A}$

## ■ ELECTRICAL CHARACTERISTICS

(Unless otherwise noted,  $V_{DD}=5V$ ,  $T_a=25^\circ C$ )

PARAMETER	SYMBOL	TEST CONDITION	MIN.	TYP.	MAX.	UNIT
<b>PWM INPUT BLOCK</b>						
PWM Input Frequency	$f_{PWM}$		2	-	50	kHz
Pullup resistance	$R_{PWM}$		-	200	-	k $\Omega$
H Level Input Voltage 1	$V_{IHP1}$		2.4	-	5	V
L Level Input Voltage 1	$V_{ILP1}$		0	-	1.4	V
H Level Input Voltage 2	$V_{IHP2}$	$V_{DD}=2V$	1.1	-	2	V
L Level Input Voltage 2	$V_{ILP2}$	$V_{DD}=2V$	0	-	0.5	V

## LOCK PROTECTION BLOCK

Lock Protection ON Time	$t_{ON}$		-	0.5	-	s
Lock Protection OFF Time	$t_{OFF}$		-	5.0	-	s
Lock Protection Ratio	$t_{RATIO}$		-	1:10	-	-

## ■ THERMAL CHARACTERISTICS

PARAMETER	SYMBOL	VALUE	UNIT
Junction-to-ambient thermal resistance	$\theta_{ja}$	243.8 <sup>(3)</sup>	$^\circ C/W$
Junction-to-Top of package characterization parameter	$\psi_{jt}$	50.9 <sup>(3)</sup>	$^\circ C/W$

(3): Mounted on glass epoxy board. (76.2×114.3×1.6mm: based on EIA/JEDEC standard, 2Layers FR-4)

## ■ POWER DISSIPATION vs. AMBIENT TEMPERATURE

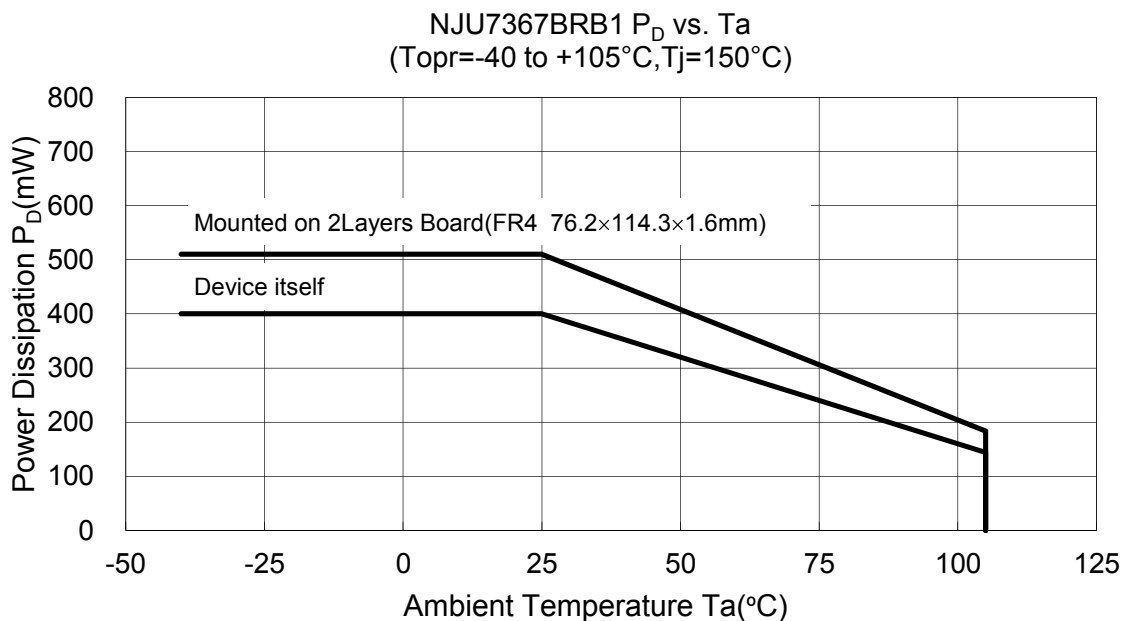

## ■ TYPICAL CHARACTERISTICS

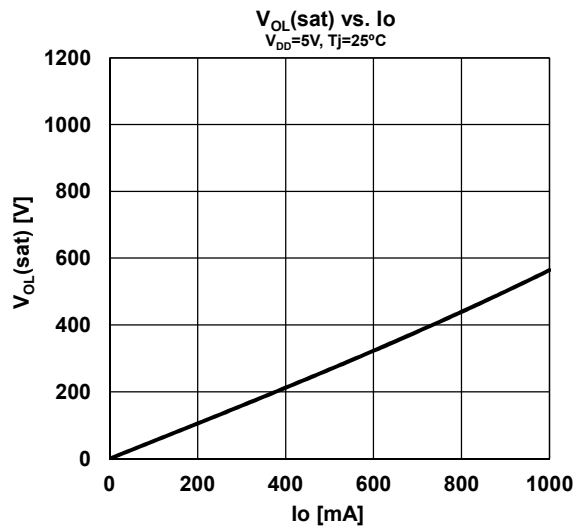
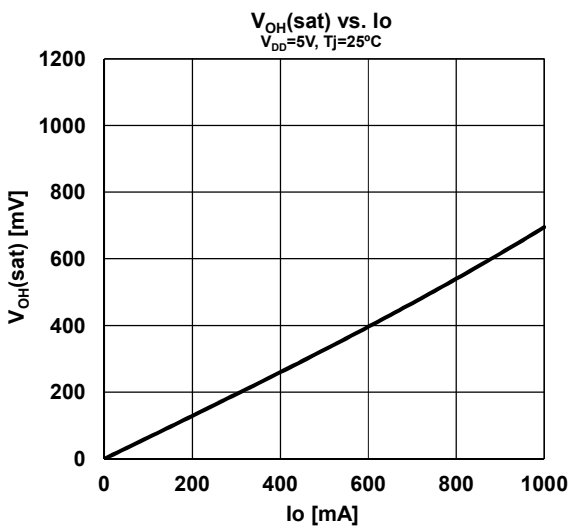
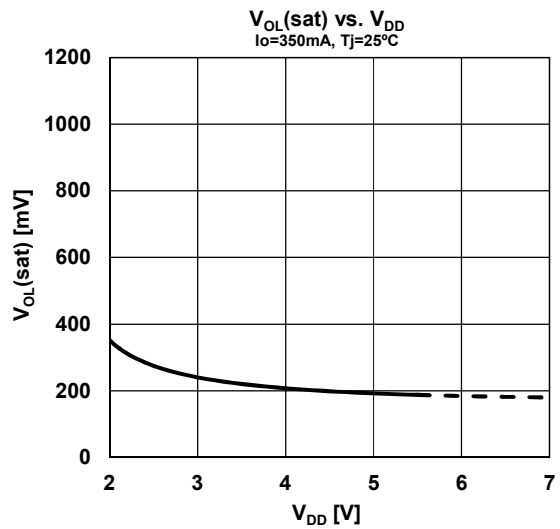
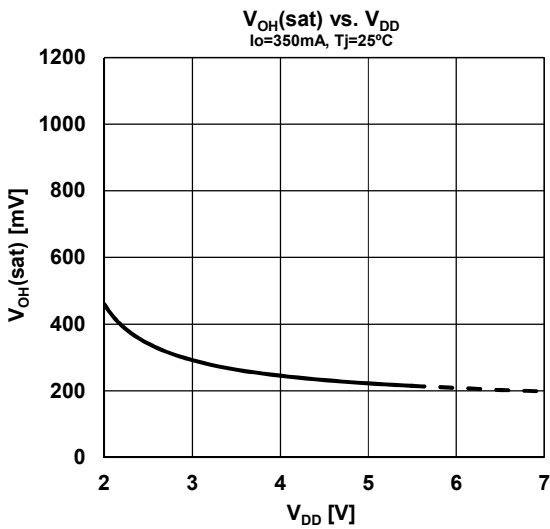
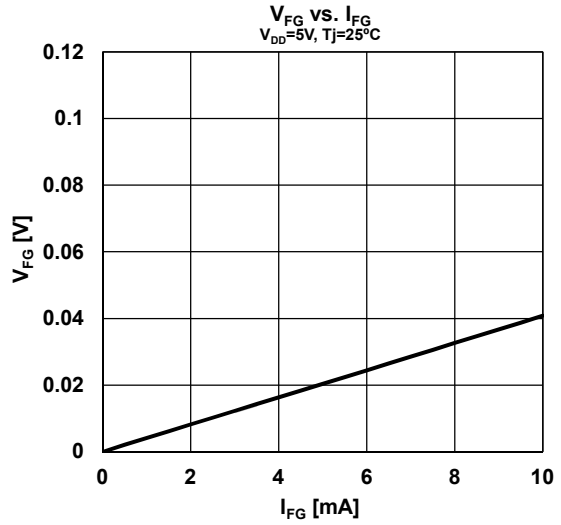
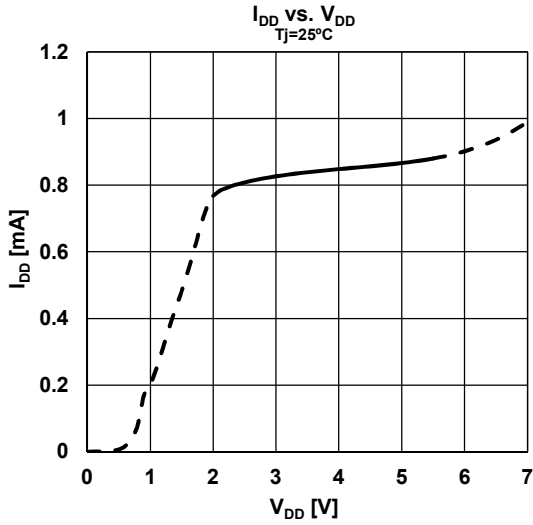

## ■ TYPICAL CHARACTERISTICS

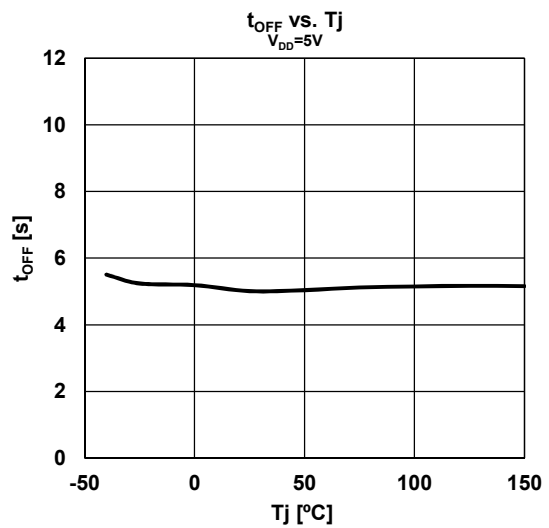
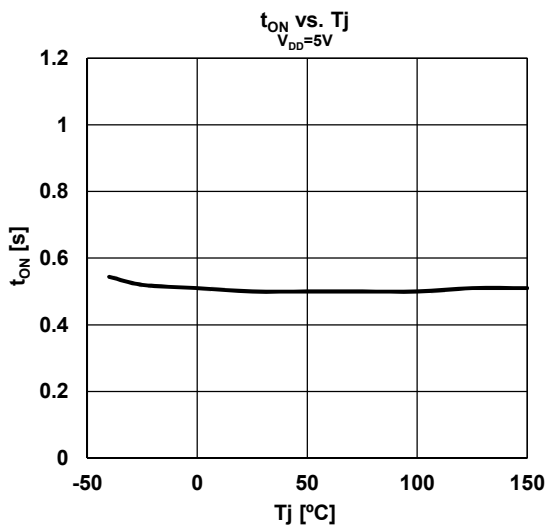
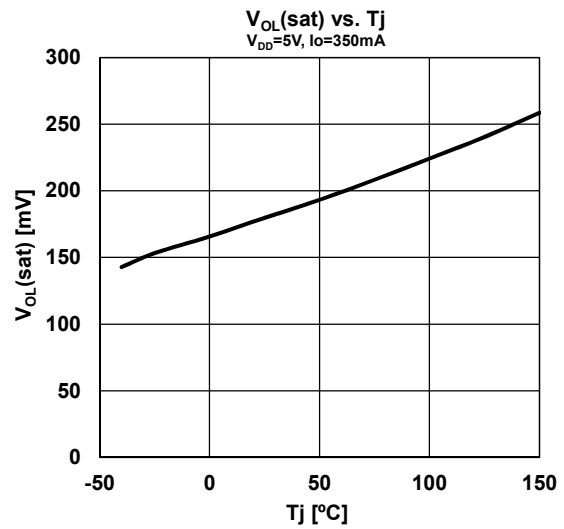
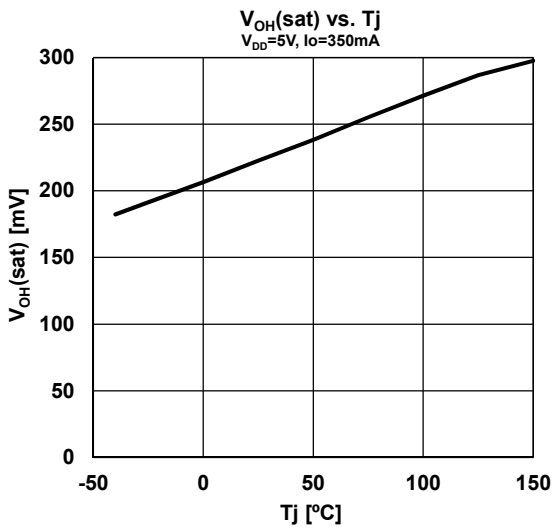
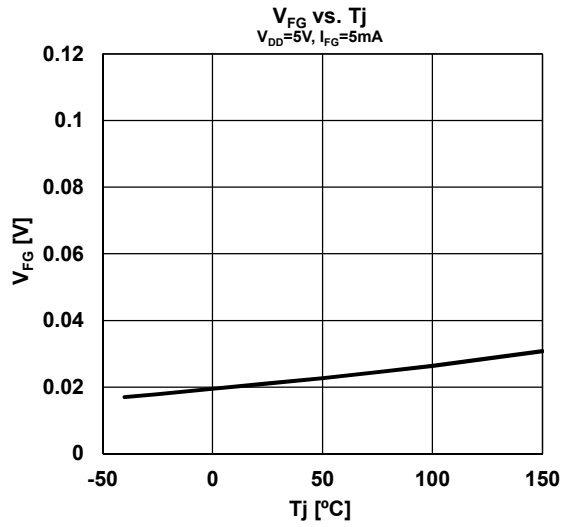
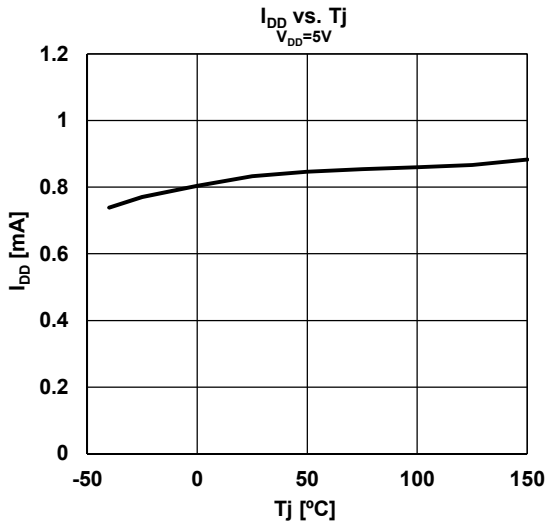

## ■APPLICATION NOTE / GLOSSARY

### ●Truth Table

IN+	IN -	PWM	TSD/LD	OUTA	OUTB	FG
H	L	H	OFF	H	L	L
L	H			L	H	Hi-Z
H	L	L		L	L	L
L	H			L	L	Hi-Z
H	L	-	ON	L	L	L
L	H					Hi-Z

### ●Timing Chart

< PWM Input >

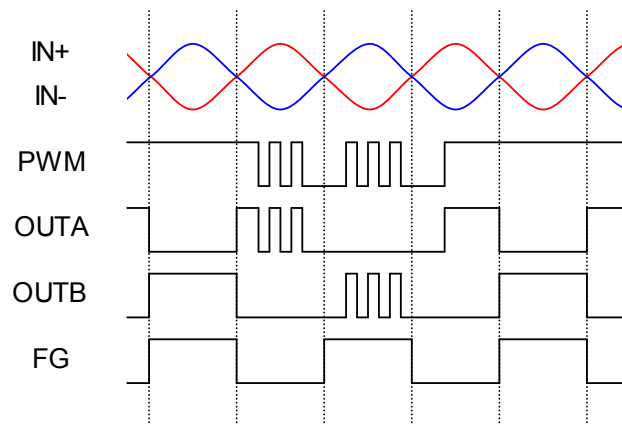

< Lock Protection Function >

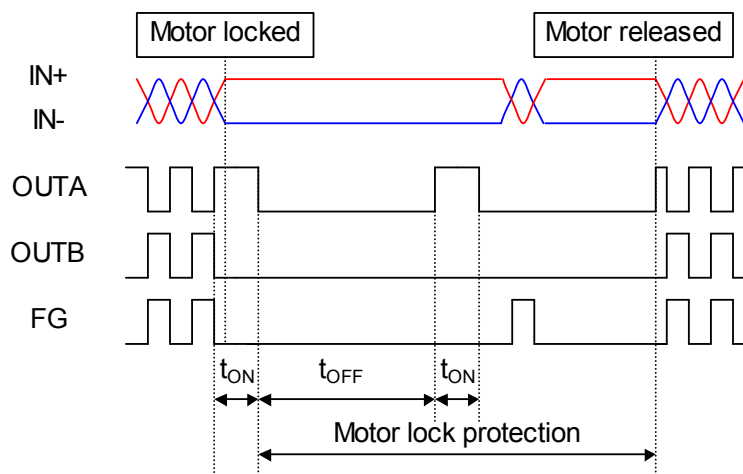

### < Quick Start Function >

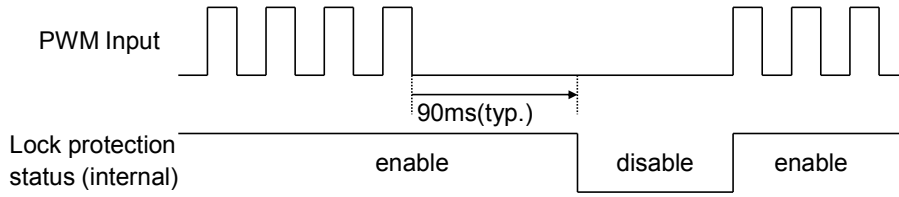

### < Start up Assist Function >

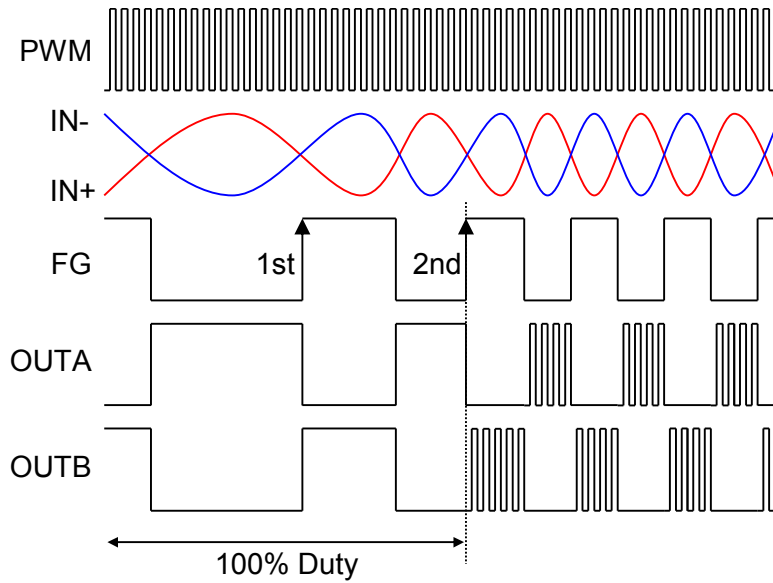



## ■ PACKAGE OUTLINE / SOLDER FOOT PRINT

MSOP8-Thin(TVSP8)

Unit: mm

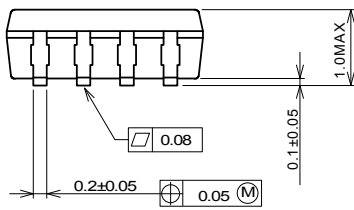
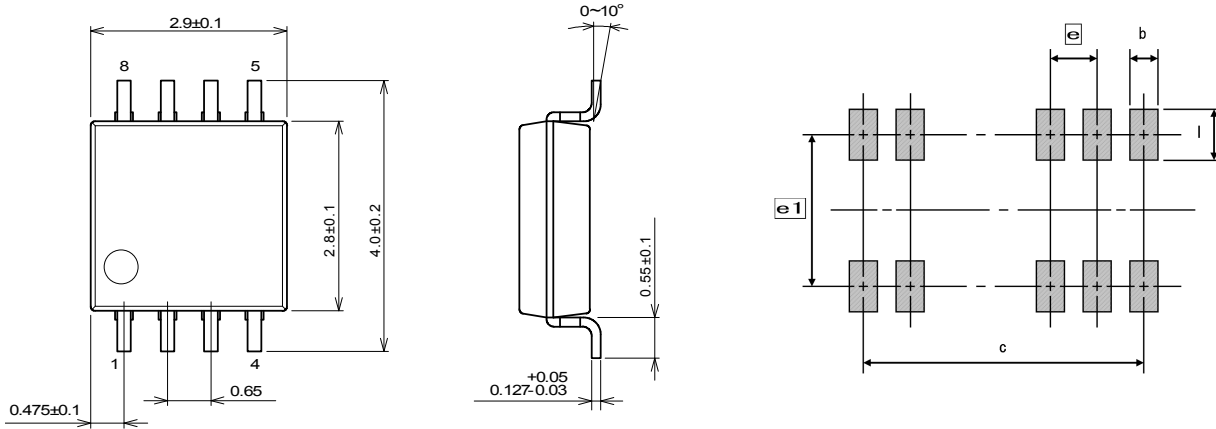

PKG	b	l	c	e1	e
TVSP8	0.23	1.00	1.95	3.50	0.65

## PACKING SPECIFICATION

NJRC delivers ICs in 4 methods, plastic tube container, two kinds of Taping, tray and vinyl bag packing. Except adhesive tape treated anti electrostatic and contain carbon are using as the ESD ( Electrostatic Discharge Damage ) protection.

### MSOP8-Thin(TVSP8) Emboss Taping (TE1)

Unit : mm

Symbol	MSOP8-Thin (TVSP8)* *MEETJEDEC MO-187-DA THIN TYPE	Remark
A	4.4	Bottom size
B	3.2	Bottom size
D <sub>0</sub>	1.5+0.1/-0	
D <sub>1</sub>	1.5+0.1/-0	
E	1.75±0.1	
F	5.5±0.05	
P <sub>0</sub>	4.0±0.1	
P <sub>1</sub>	8.0±0.1	
P <sub>2</sub>	2.0±0.05	
T	0.3±0.05	
T <sub>2</sub>	1.45	
W	12.0±0.3	
W <sub>1</sub>	9.5	Thickness 0.1MAX

Symbol	MSOP8-Thin (TVSP8)* *MEETJEDEC MO-187-DA THIN TYPE
A	∅254±2
B	∅100±1
C	∅13±0.2
D	∅21±0.8
E	2±0.5
W	13.5±0.5
W <sub>1</sub>	2±0.2
Contents	2,000 pcs

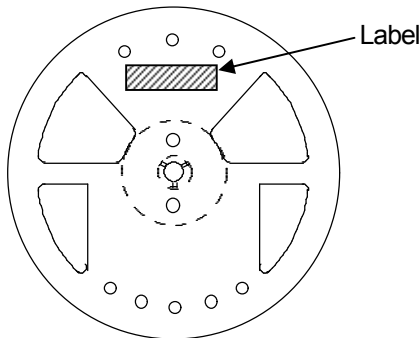
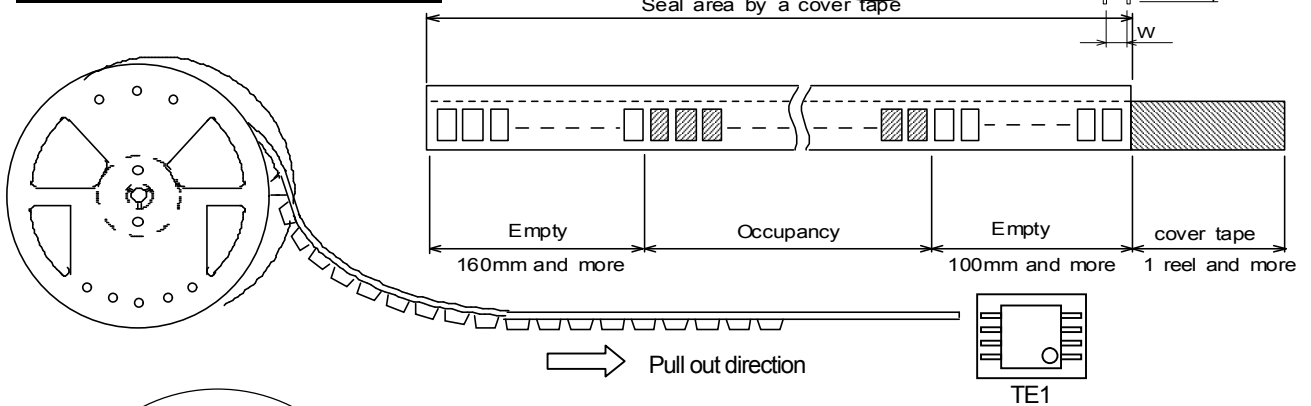
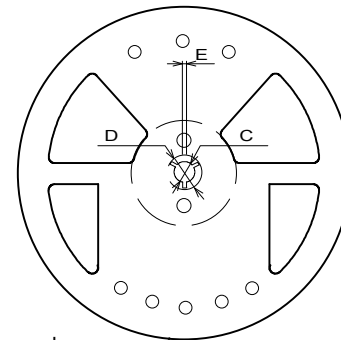
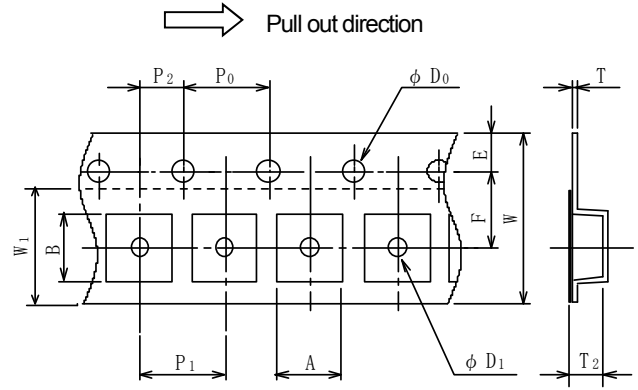

Put in the outer box

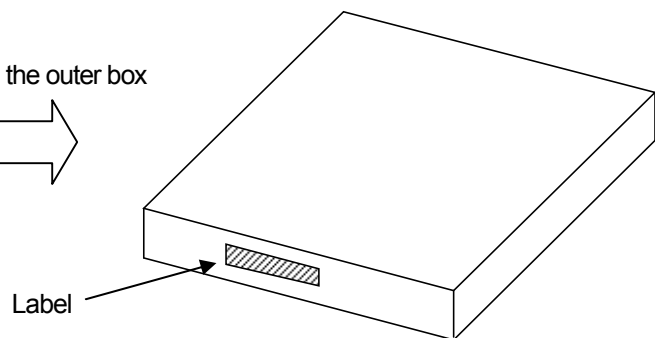
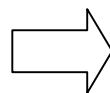

## ■RECOMMENDED MOUNTING METHOD

### •INFRARED REFLOW SOLDERING METHOD

\*reflow soldering procedure

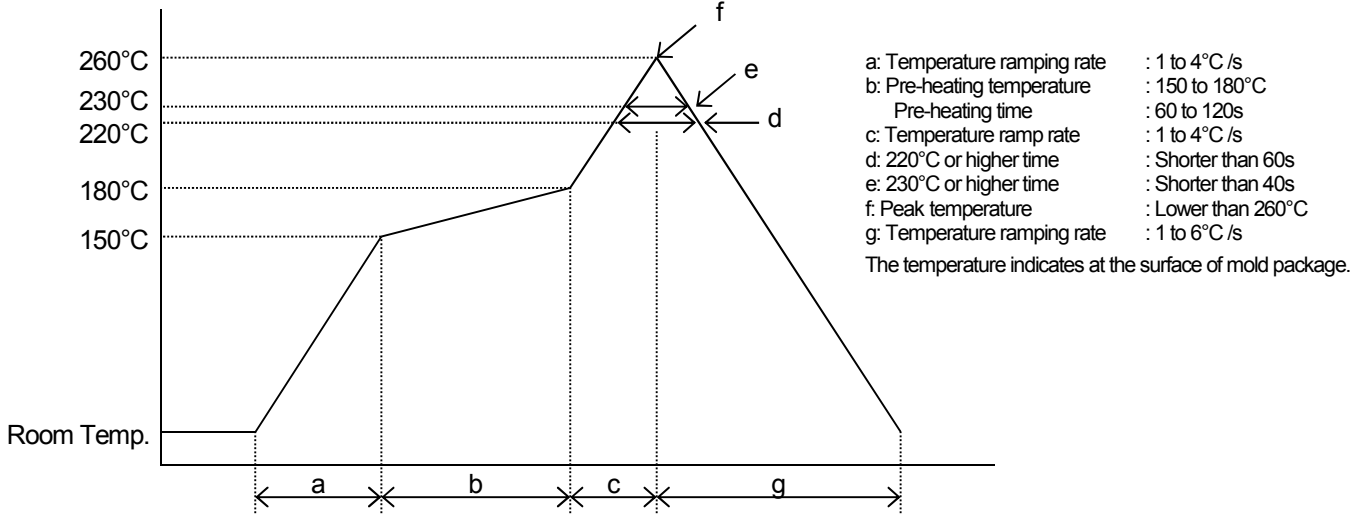

### •INFRARED FLOW SOLDERING METHOD

\*flow soldering procedure

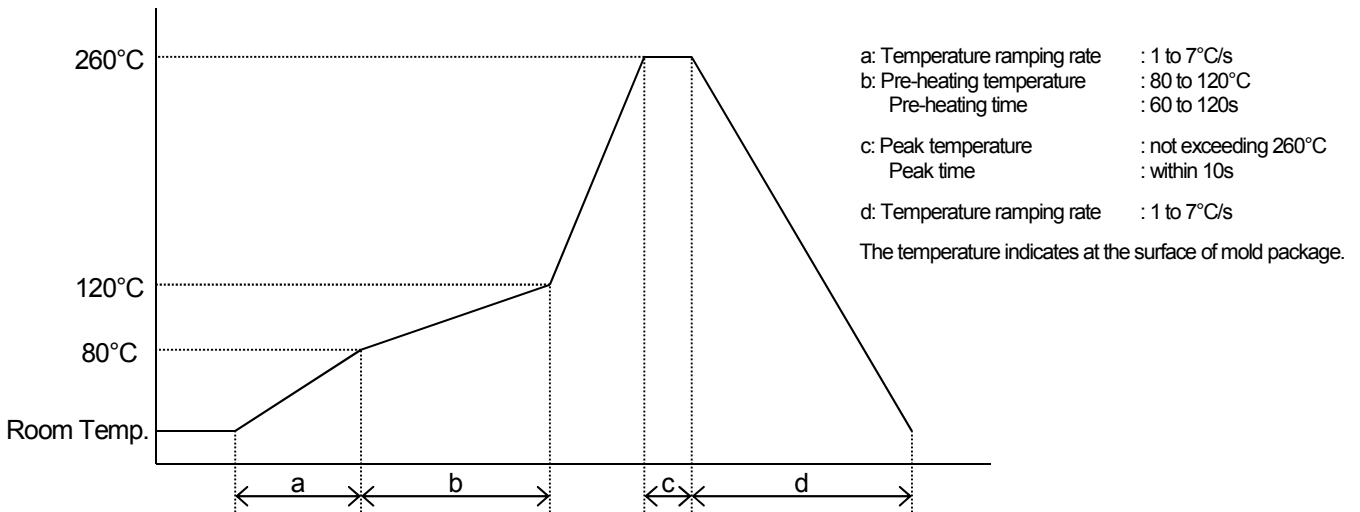

**■REVISION HISTORY**

Date	Revision	Changes
28.Nov.2016	Ver.1.0	New Release

**[ CAUTION ]**

1. New JRC strives to produce reliable and high quality semiconductors. New JRC's semiconductors are intended for specific applications and require proper maintenance and handling. To enhance the performance and service of New JRC's semiconductors, the devices, machinery or equipment into which they are integrated should undergo preventative maintenance and inspection at regularly scheduled intervals. Failure to properly maintain equipment and machinery incorporating these products can result in catastrophic system failures
2. The specifications on this datasheet are only given for information without any guarantee as regards either mistakes or omissions. The application circuits in this datasheet are described only to show representative usages of the product and not intended for the guarantee or permission of any right including the industrial rights. All other trademarks mentioned herein are property of their respective companies.
3. To ensure the highest levels of reliability, New JRC products must always be properly handled. The introduction of external contaminants (e.g. dust, oil or cosmetics) can result in failures of semiconductor products.
4. New JRC offers a variety of semiconductor products intended for particular applications. It is important that you select the proper component for your intended application. You may contact New JRC's Sale's Office if you are uncertain about the products listed in this catalog.
5. Special care is required in designing devices, machinery or equipment which demand high levels of reliability. This is particularly important when designing critical components or systems whose failure can foreseeably result in situations that could adversely affect health or safety. In designing such critical devices, equipment or machinery, careful consideration should be given to amongst other things, their safety design, fail-safe design, back-up and redundancy systems, and diffusion design.
6. The products listed in the catalog may not be appropriate for use in certain equipment where reliability is critical or where the products may be subjected to extreme conditions. You should consult our sales office before using the products in any of the following types of equipment.
  - Aerospace Equipment
  - Equipment Used in the Deep sea
  - Power Generator Control Equipment (Nuclear, Steam, Hydraulic)
  - Life Maintenance Medical Equipment
  - Fire Alarm/Intruder Detector
  - Vehicle Control Equipment (airplane, railroad, ship, etc.)
  - Various Safety devices
7. New JRC's products have been designed and tested to function within controlled environmental conditions. Do not use products under conditions that deviate from methods or applications specified in this catalog. Failure to employ New JRC products in the proper applications can lead to deterioration, destruction or failure of the products. New JRC shall not be responsible for any bodily injury, fires or accident, property damage or any consequential damages resulting from misuse or misapplication of its products. Products are sold without warranty of any kind, either express or implied, including but not limited to any implied warranty of merchantability or fitness for a particular purpose.
8. Warning for handling Gallium and Arsenic(GaAs) Products (Applying to GaAs MMIC, Photo Reflector). This Products uses Gallium(Ga) and Arsenic(As) which are specified as poisonous chemicals by law. For the prevention of a hazard, do not burn, destroy, or process chemically to make them as gas or power. When the product is disposed, please follow the related regulation and do not mix this with general industrial waste or household waste.
9. The product specifications and descriptions listed in this catalog are subject to change at any time, without notice.

