



2-CHANNEL Audio Processor with eala surround

■ GENERAL DESCRIPTION

The NJU7391 is a 2-channel Audio Processor with 5-in 1-out stereo audio selector, 2-band Tone Control and eala surround. The NJU7391 performs low noise and low distortion characteristics with resistance ladder circuit.

All of functions are controlled via three-wired serial bus.

■ PACKAGE OUTLINE



NJU7391V

■ FEATURES

- Operating Voltage +4.7 to +9.7V
- Three-wired serial bus
- Low output noise -110dBVtyp.
- Low THD 0.002%typ. (Vin=1Vrms, VOL=0dB)
0.010%typ. (Vin=2Vrms, VOL=0dB)
- Input Selector(X5)
- Input Gain 0 to +14dB/2dBstep
- Volume 0 to -95.0dB / 1dBstep, MUTE
- Tone Control 0 to ±14dB/2dBstep
- eala Surround 3-level effects
- CMOS Technology
- Package Outline SSOP32

■ BLOCK DIAGRAM

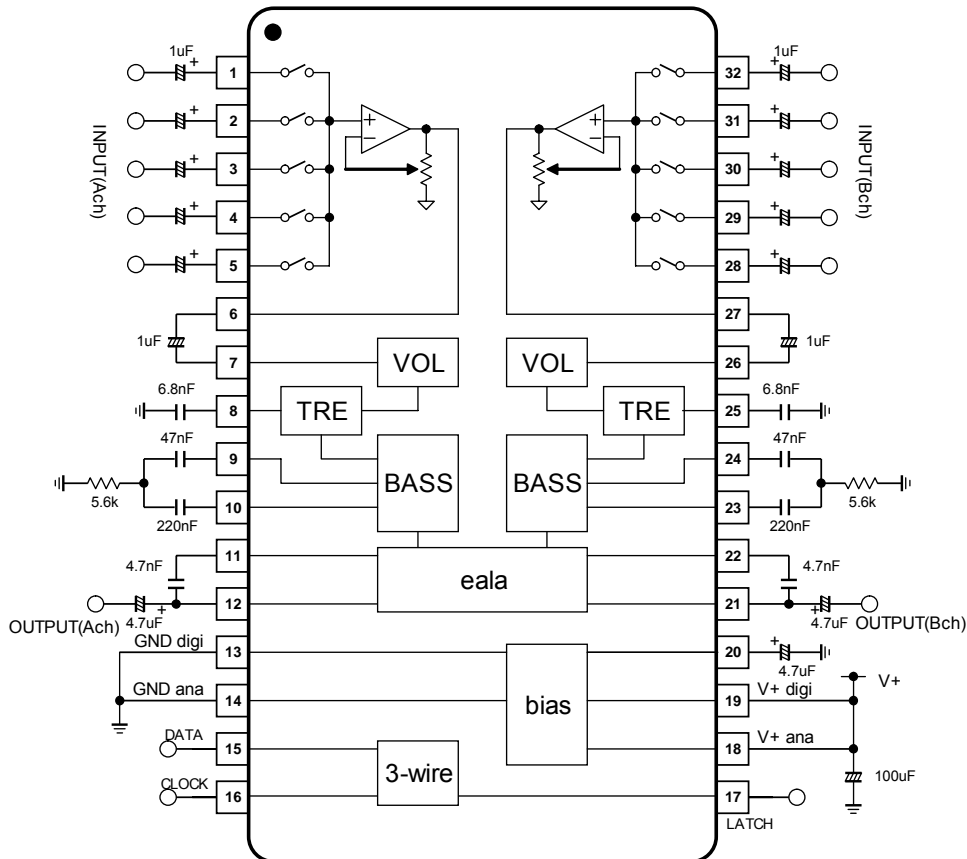

■PIN CONFIGURATION

SSOP32

1	IN1A	IN1B	32
2	IN2A	IN2B	31
3	IN3A	IN3B	30
4	IN4A	IN4B	29
5	IN5A	IN5B	28
6	SELOUTA	SELOUTB	27
7	VOL1A	VOL1B	26
8	TONE-HA	TONE-HB	25
9	TONE-BA	TONE-BB	24
10	TONE-DBA	TONE-DBB	23
11	SRA	SRB	22
12	OUTA	OUTB	21
13	GND D	VREF	20
14	GND A	V+ D	19
15	DATA	V+ A	18
16	CLOCK	LATCH	17

No.	Symbol	Function	No	Symbol	Function
1	IN1A	Ach Input1 Terminal	17	LATCH	3-Wired LATCH Input Terminal
2	IN2A	Ach Input2 Terminal	18	V+ A	Analog Supply Terminal
3	IN3A	Ach Input3 Terminal	19	V+ D	Digital Supply Terminal
4	IN4A	Ach Input4 Terminal	20	VREF	Reference Voltage Terminal
5	IN5A	Ach Input5 Terminal	21	OUTB	Bch Output Terminal
6	SELOUTA	Ach Selector Output Terminal	22	SRB	Bch Surround Filter Terminal
7	VOL1A	Ach Volume Input Terminal	23	TONE-DBB	Bch Bass(Tone) Filter Terminal
8	TONE-HA	Ach Treble(Tone) Filter Terminal	24	TONE-BB	Bch Bass(Tone) Filter Terminal
9	TONE-BA	Ach Bass(Tone) Filter Terminal	25	TONE-HB	Bch Treble(Tone) Filter Terminal
10	TONE-DBA	Ach Bass(Tone) Filter Terminal	26	VOL1B	Bch Volume Input Terminal
11	SRA	Ach Surround Filter Terminal	27	SELOUTB	Bch Selector Output Terminal
12	OUTA	Ach Output Terminal	28	IN5B	Bch Input5 Terminal
13	GND D	Digital Ground Terminal	29	IN4B	Bch Input4 Terminal
14	GND A	Analog Ground Terminal	30	IN3B	Bch Input3 Terminal
15	DATA	3-Wired DATA Input Terminal	31	IN2B	Bch Input2 Terminal
16	CLOCK	3-Wired CLOCK Input Terminal	32	IN1B	Bch Input1 Terminal

■ ABSOLUTE MAXIMUM RATING (Ta=25°C)

PARAMETER	SYMBOL	RATING	UNIT
Power Supply Voltage	V ₊	10 (Note1)	V
Power Dissipation	P _D	800 (Note2)	mW
Maximum Input Voltage	V _{IMAX}	0 ~ V ₊ (Note3)	V
Operating Temperature Range	Topr	-40 ~ +85	°C
Storage Temperature Range	Tstg	-40 ~ +125	°C

(Note1) Pay attention to supply voltage not to exceed the absolute maximum power supply voltage by spike noise etc. Because the difference between the absolute maximum power supply voltage and the operating voltage is small.

(Note2) EIA/JEDEC STANDARD Test board (76.2x114.3x1.6mm, 2layer, FR-4) mounting

(Note3) Don't apply the input voltage that exceeds supply voltage.

■ ELECTRICAL CHARACTERISTICS (Ta=25°C, V⁺=9V, RL=47kΩ, Vin=100mVrms/1kHz, VOL=0dB, TONE=OFF, SUR=OFF)

PARAMETER	SYMBOL	TEST CONDITION	MIN.	TYP.	MAX.	UNIT
Operating Voltage	V ₊		4.7	9.0	9.7	V
Supply Current	I _{DD}	No signal	-	10	18	mA
Reference Voltage	V _{REF}	No signal	3.5	4.0	4.5	V
Input impedance	R _{IN}		-	60	-	kΩ
Output impedance	R _{OUT}		-	200	-	Ω
Maximum Input Voltage	V _{IM}	VOL=0dB, THD=1%	-	3.0	-	Vrms
Maximum Output Voltage	V _{OM}	OUTPUT VOL=0dB, THD=1%	-	3.0	-	Vrms
Maximum Gain	G _{VMAX}	VOL=0dB	-1.0	0	1.0	dB
Minimum Gain	G _{VMIN}	V _{IN} =1Vrms, VOLA/B=MUTE	-	-100	-90	dB
Maximum Input Gain	G _{VINMAX}	GVIN="111" (+14dB)	-	14	-	dB
Channel Balance	G _{CB}	VOL=0dB	-1	0	1	dB
Cross Talk	CT	V _{IN} =1Vrms Selected Input : 0Ω Unselected Input : Signal	-	-	-80	dB
Channel Separation	CS	V _{IN} =1Vrms	-	-	-80	dB
Total Harmonic Distortion 1	THD+N1	V _O =1Vrms, BW=400Hz-30kHz	-	0.002	0.01	%
Total Harmonic Distortion 2	THD+N2	V _O =2Vrms, BW=400Hz-30kHz	-	0.01	-	%
Output Noise	V _{NO}	Rg=0Ω, A-weight	-	-110	-97	dBV

◆ Tone Control Characteristics

PARAMETER	SYMBOL	TEST CONDITION	MIN.	TYP.	MAX.	UNIT
High Frequency Boost	HF _{BST}	BCT="1", TREB="111", f=10kHz	11.5	14.0	16.5	dB
High Frequency Cut	HF _{CUT}	BCT="0", TREB="111", f=10kHz	-16.5	-14.0	-11.5	dB
Low Frequency Boost	LF _{BST}	BCB="1", BASS="111", f=100Hz	11.5	14.0	16.5	dB
Low Frequency Cut	LF _{CUT}	BCB="0", BASS="111", f=100Hz	-16.5	-14.0	-11.5	dB

◆Surround (eala) Characteristics

PARAMETER	SYMBOL	TEST CONDITION	MIN.	TYP.	MAX.	UNIT
Surround 1	SUR ₁	SUR="01", f=100Hz, Ain-Aout	1.6	3.6	5.6	dB
Surround 2	SUR ₂	SUR="10", f=100Hz, Ain-Aout	4.3	6.3	8.3	dB
Surround 3	SUR ₃	SUR="11", f=100Hz, Ain-Aout	6.6	8.6	10.6	dB
Surround 4	SUR ₄	SUR="11", f=100Hz, Ain-Bout	2.8	4.8	6.8	dB

◆Logic Control Characteristics

PARAMETER	SYMBOL	TEST CONDITION	MIN.	TYP.	MAX.	UNIT
High Level Input Voltage	V _{IH}	DATA,CLOCK,LATCH	2.6	-	5.5	V
Low Level Input Voltage	V _{IL}	DATA,CLOCK,LATCH	0	-	1.0	V

■ CONTROL DATA FORMAT

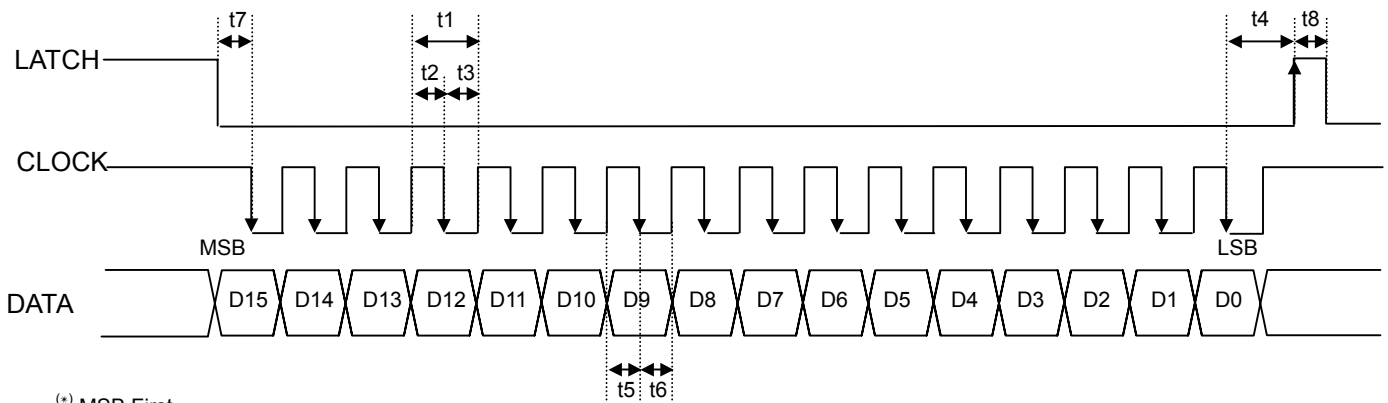

(*) MSB First

SYMBOL	PARAMETER	MIN	TYP	MAX	UNIT
t1	CLOCK Clock Width	4	-	-	μsec
t2	CLOCK Pulse Width (High)	2	-	-	μsec
t3	CLOCK Pulse Width (Low)	2	-	-	μsec
t4	LATCH Rise Hold Time	4	-	-	μsec
t5	DATA Setup Time	1.6	-	-	μsec
t6	DATA Hold Time	1.6	-	-	μsec
t7	CLOCK Setup Time	1.6	-	-	μsec
t8	LATCH High Pulse Width	1.6	-	-	μsec

■ CONTROL DATA

NJU7391 control data is constructed with 16bits.

MSB															LSB
D15	D14	D13	D12	D11	D10	D9	D8	D7	D6	D5	D4	D3	D2	D1	D0
Data								Select Address				Chip Address			

MSB

D15	D14	D13	D12	D11	D10	D9	D8	D7	D6	D5	D4	D3	D2	D1	D0				
Don't Care								VOLA				0	0	0	0	0	1	0	1
Don't Care								VOLB				0	0	0	1	0	1	0	1
BCB		BAS			BCT		TRE			0	0	1	0	0	1	0	1		
SUR			SEL			GVIN			0	0	1	1	0	1	0	1			

LSB

■ INITIAL CONDITION

MSB

MSB															LSB
D15	D14	D13	D12	D11	D10	D9	D8	D7	D6	D5	D4	D3	D2	D1	D0
0	0	0	0	0	0	0	0	0	0	0	0	0	1	0	1
0	0	0	0	0	0	0	0	0	0	0	1	0	1	0	1
0	0	0	0	0	0	0	0	0	0	1	0	0	1	0	1
0	0	0	0	0	0	0	0	0	0	1	1	0	1	0	1

■ DEFINITION OF RESISTOR

◆Volume A, Volume B 0dB to -95dB in 1dB/step. *Each volume is controlled independently.

D15	D14	D13	D12	D11	D10	D9	D8	D7	D6	D5	D4	D3	D2	D1	D0
Don't Care	VOLA							0	0	0	0	0	1	0	1
Don't Care	VOLB							0	0	0	1	0	1	0	1

< Volume Control Data >

Data							Setting
D14	D13	D12	D11	D10	D9	D8	
1	1	1	1	1	1	1	0dB (*)
1	1	1	1	1	1	0	-1dB
1	1	1	1	1	0	1	-2dB
1	1	1	1	1	0	0	-3dB
1	1	1	1	0	1	1	-4dB
1	1	1	1	0	1	0	-5dB
1	1	1	1	0	0	1	-6dB
1	1	1	1	0	0	0	-7dB
1	1	1	0	1	1	1	-8dB
1	1	1	0	1	1	0	-9dB
1	1	1	0	1	0	1	-10dB
1	1	1	0	1	0	0	-11dB
1	1	1	0	0	1	1	-12dB
1	1	1	0	0	1	0	-13dB
1	1	1	0	0	0	1	-14dB
1	1	1	0	0	0	0	-15dB
1	1	0	1	1	1	1	-16dB
...							...
0	1	0	1	1	1	1	-80dB
0	1	0	0	1	1	1	-88dB
0	1	0	0	0	0	0	-95dB
0	0	Don't Care					MUTE(*)

(*)Initial Setting

Tone Control

D15	D14	D13	D12	D11	D10	D9	D8	D7	D6	D5	D4	D3	D2	D1	D0
BCB	BAS			BCT	TRE			0	0	1	0	0	1	0	1

- BCB : Boost Cut select for Bass control
 "0" : Cut
 "1" : Boost
- BAS : BASS Level Setting
 Cut Level : -14 to 0dB (2dB/step)
 Boost Level : 0 to +14dB (2dB/step)
- BCT : Boost Cut select for Treble control
 "0" : Cut
 "1" : Boost
- TRE : BASS Level Setting
 Cut Level : -14 to 0dB (2dB/step)
 Boost Level : 0 to +14dB (2dB/step)

< Tone Control Data >

- BAS: TONE-BASS Level

Data				Setting
D15	D14	D13	D12	
BCB	BAS			
1	1	1	1	+14dB
1	1	1	0	+12dB
1	1	0	1	+10dB
1	1	0	0	+8dB
1	0	1	1	+6dB
1	0	1	0	+4dB
1	0	0	1	+2dB
1	0	0	0	0dB
0	0	0	0	0dB (*)
0	0	0	1	-2dB
0	0	1	0	-4dB
0	0	1	1	-6dB
0	1	0	0	-8dB
0	1	0	1	-10dB
0	1	1	0	-12dB
0	1	1	1	-14dB

(*)Initial Setting

- TRE: TONE-TREBLE Level

Data				Setting
D11	D10	D9	D8	
BCT	TRE			
1	1	1	1	+14dB
1	1	1	0	+12dB
1	1	0	1	+10dB
1	1	0	0	+8dB
1	0	1	1	+6dB
1	0	1	0	+4dB
1	0	0	1	+2dB
1	0	0	0	0dB
0	0	0	0	0dB (*)
0	0	0	1	-2dB
0	0	1	0	-4dB
0	0	1	1	-6dB
0	1	0	0	-8dB
0	1	0	1	-10dB
0	1	1	0	-12dB
0	1	1	1	-14dB

(*)Initial Setting

◆Surround(eala), Input Selector, Input Gain

D15	D14	D13	D12	D11	D10	D9	D8	D7	D6	D5	D4	D3	D2	D1	D0
SUR		SEL			GVIN			0	0	1	1	0	1	0	1

< Surround(eala) Data >

Data		Setting
D15	D14	
0	0	BYPASS (*)
0	1	Surround1(MIN)
1	0	Surround2(MID)
1	1	Surround3(MAX)

(*)initial setting

< Input Selector Data >

Data			Setting
D13	D12	D11	
0	0	0	Input 1 (*)
0	0	1	Input 2
0	1	0	Input 3
0	1	1	Input 4
1	0	0	Input 5

(*)initial setting

< Input Gain Data >

Data			Setting
D10	D9	D8	
0	0	0	BYPASS (*)
0	0	1	+2dB
0	1	0	+4dB
0	1	1	+6dB
1	0	0	+8dB
1	0	1	+10dB
1	1	0	+12dB
1	1	1	+14dB

(*)initial setting

■TERMINAL DESCRIPTION

No.	SYMBOL	FUNCTION	EQUIVALENT CIRCUIT	VOLTAGE
1 2 3 4 5 28 29 30 31 32	IN1A IN2A IN3A IN4A IN5A IN5B IN4B IN3B IN2B IN1B	Ach input1 terminal Ach input2 terminal Ach input3 terminal Ach input4 terminal Ach input5 terminal Bch input5 terminal Bch input4 terminal Bch input3 terminal Bch input2 terminal Bch input1 terminal		V+ * (4/9)
6 9 12 21 24 27	SELOUTA TONE-BA OUTA OUTB TONE-BB SELOUTB	Ach selector output terminal Ach Bass(tone) filter terminal Ach output terminal Bch output terminal Bch Bass(tone) filter terminal Bch selector output terminal		V+ * (4/9)
7 26	VOL1A VOL1B	Ach Volume input terminal Bch Volume input terminal		V+ * (4/9)
8 10 23 25	TONE-HA TONE-DBA TONE-DBB TONE-HB	Ach Treble(tone) filter terminal Ach Bass(tone) filter terminal Bch Bass(tone) filter terminal Bch Treble(tone) filter terminal		V+ * (4/9)
11 22	SRA SRB	Ach Surround filter terminal Bch Surround filter terminal		V+ * (4/9)

NJU7391

www.DataSheet4U.com

■TERMINAL DESCRIPTION

No.	SYMBOL	FUNCTION	EQUIVALENT CIRCUIT	VOLTAGE
15 16 17	DATA CLOCK LATCH	3-Wired DATA terminal 3-Wired CLOCK terminal 3-Wired LATCH terminal		
20	VREF	Reference voltage terminal		$V+ * (4/9)$

APPLICATION CIRCUIT

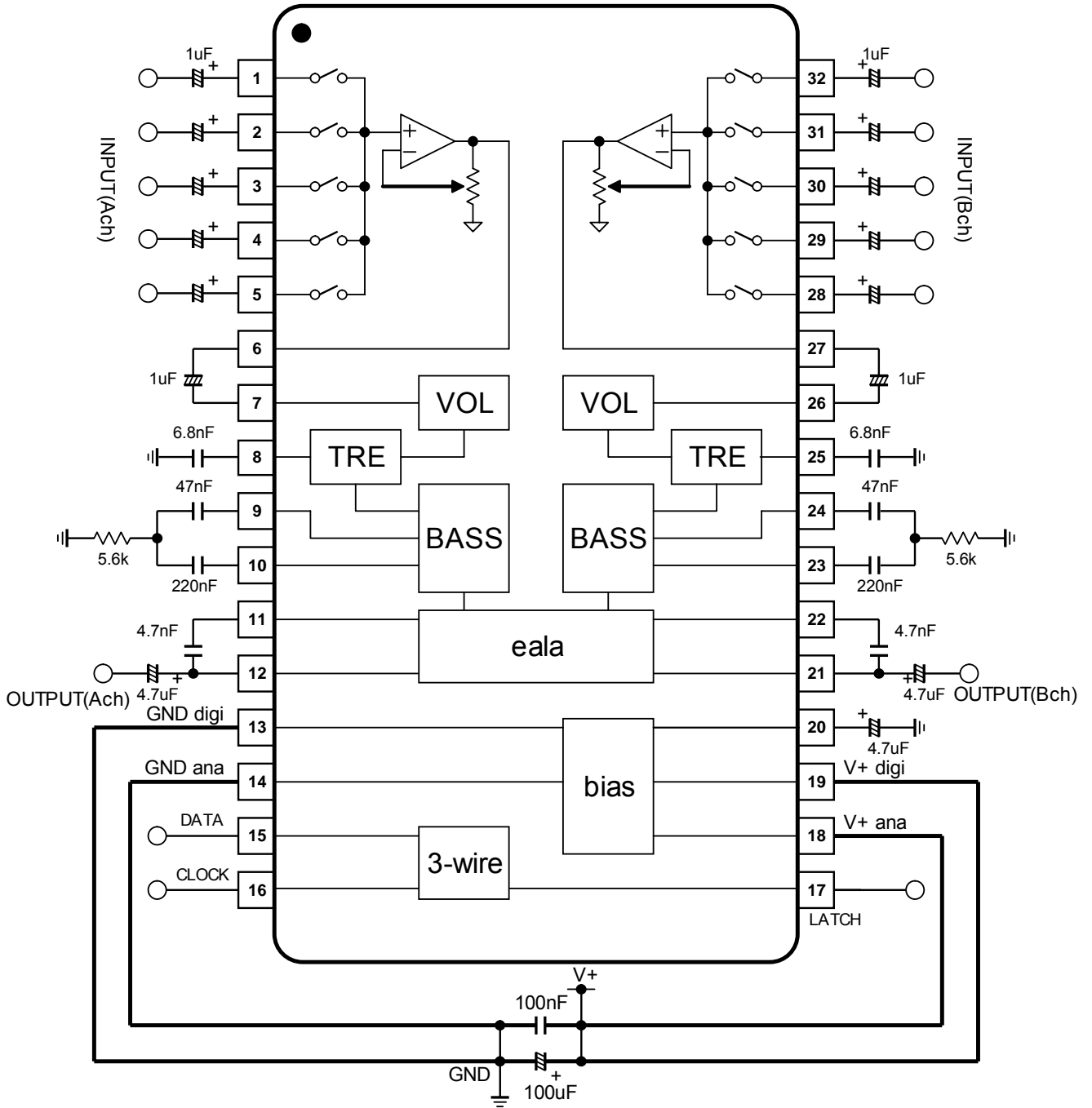

Please connect the wiring for the de-coupling capacitor (especially C13) between V+ and GND as short as possible to reduce the digital bus noise.

■ TYPICAL CHARACTERISTICS

Supply Current vs Supply Voltage
Ta=25°C

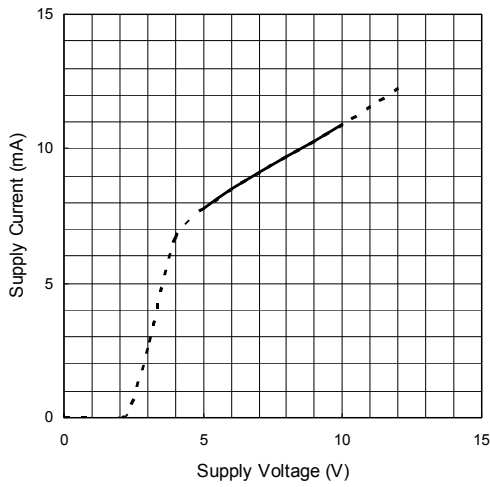

Supply Current vs Temperature
V+=9V

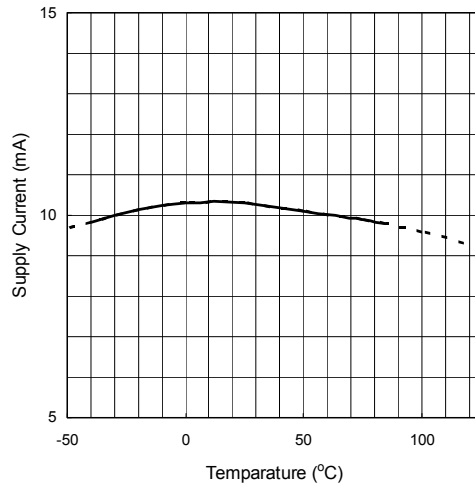

Gain vs Volume Control
V+=9V, Vin(VoIIN)=1Vrms, f=1kHz, Rg=0Ω

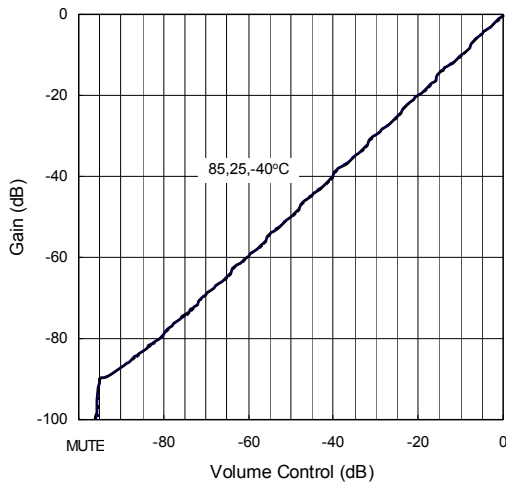

Gain vs Frequency (Volume)

V+=9V, VOL=0dB to MUTE -10dBstep, Vin=1Vrms, Ta=25°C

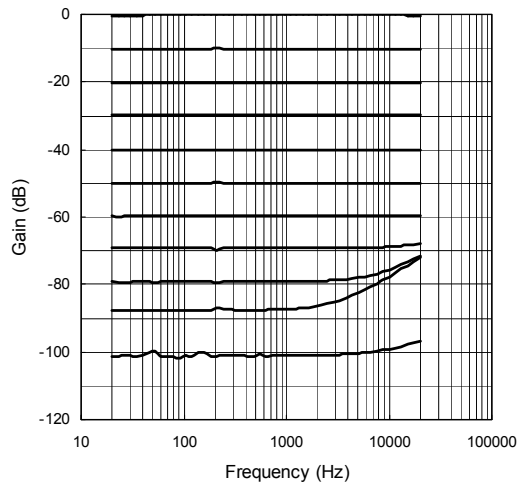

MUTE Level vs Frequency (MUTE)

V+=9V, Vin(VoIIN)=1Vrms, Vol=MUTE, Rg=0Ω, Ta=25°C

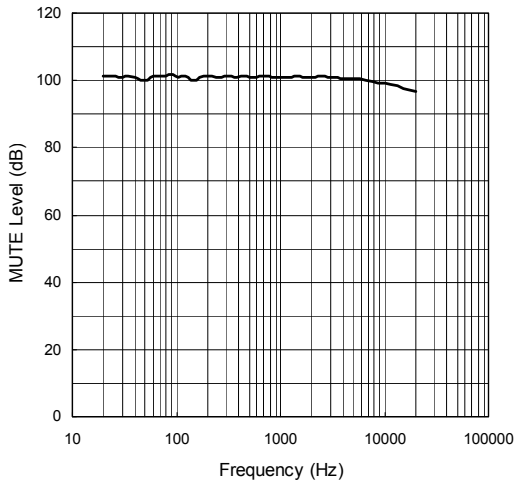

Channel Separation vs Frequency

V+=9V, Vin=1Vrms, Vo=OUTPUT, Rg=0Ω, Vol=0dB, Ta=25°C

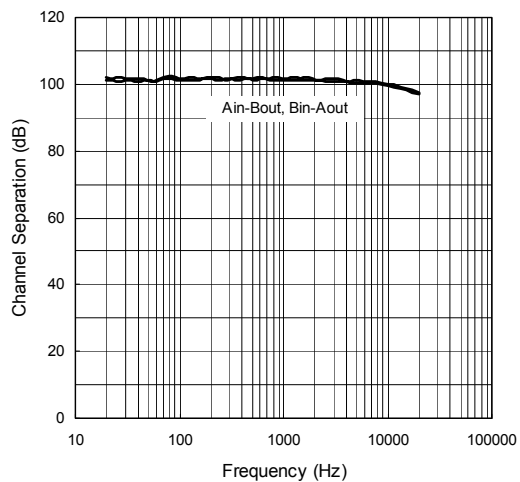

■ TYPICAL CHARACTERISTICS

Cross Talk vs Frequency

V+=9V, Vin(SEL2-5)=1Vrms, Vin(SEL1)=GND, Vo=OUTPUT,
Rg=0Ω, Vol=0dB, Ta=25°C

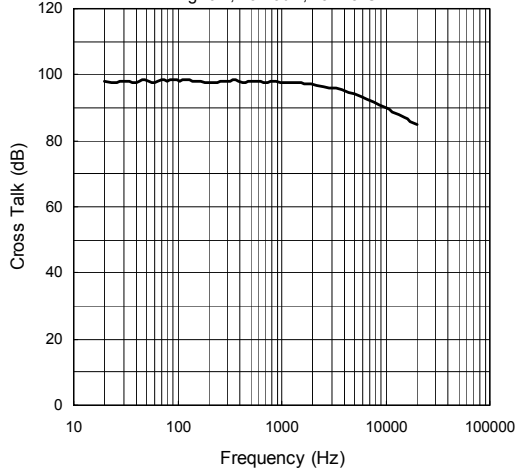

THD+N vs Output Voltage (Volume Sweep)

V+=9V, Vin(Ach), f=1kHz, Vo(Ach)OUTPUT, Rg=0Ω,
BW=20Hz-20kHz, Ta=25°C

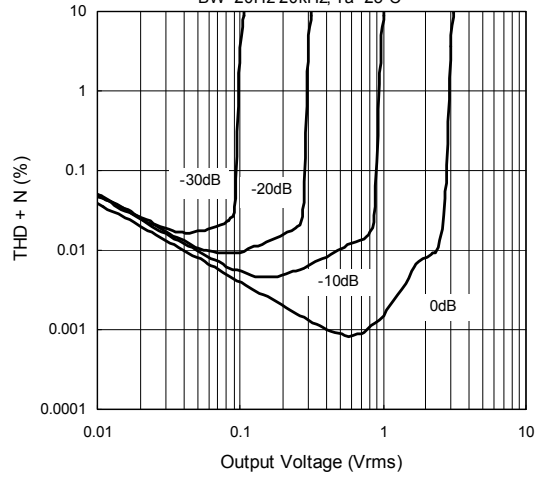

THD+N vs Output Voltage

V+=9V, Vin(Ach), f=1kHz, Vo(Ach)OUTPUT, Rg=0Ω,
BW=20Hz-20kHz

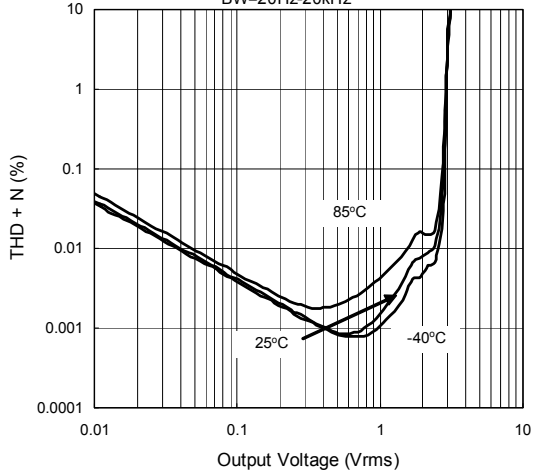

THD+N vs Output Voltage (Frequency Sweep)

V+=9V, Vin(Ach), Vo(Ach)OUTPUT, Rg=0Ω,
BW=20Hz-80kHz, Ta=25°C

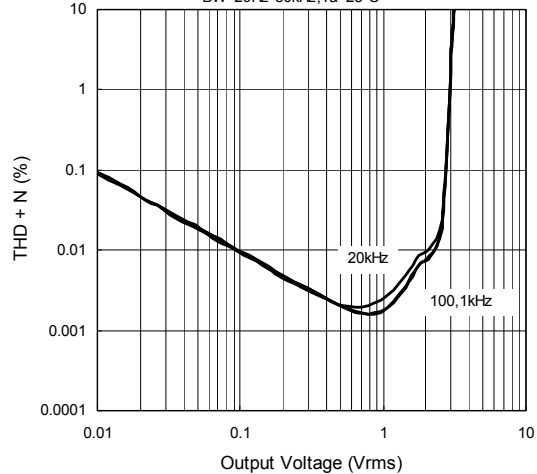

Output Noise vs Temperature

V+=9V, Vin=GND, Rg=0Ω, A-weight

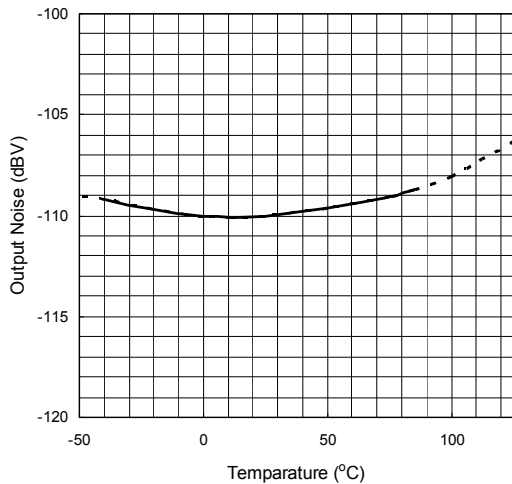

■ TYPICAL CHARACTERISTICS

Gain vs Frequency (TONE BASS)

V+=9V, Vin=0.1Vrms, BASS Gain=2dB steps, Ta=25°C

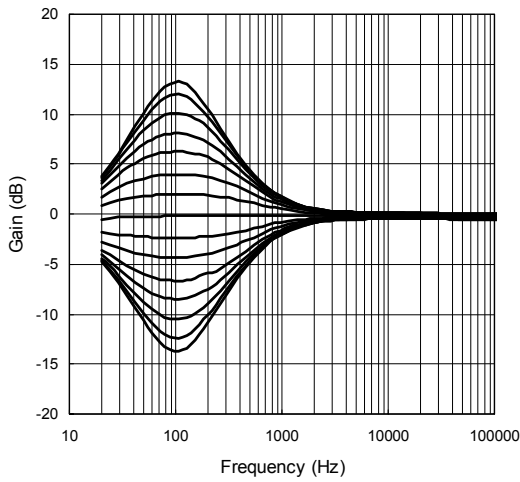

Gain vs Frequency (TONE TREB)

V+=9V, Vin=0.1Vrms, TREB Gain=2dB steps, Ta=25°C

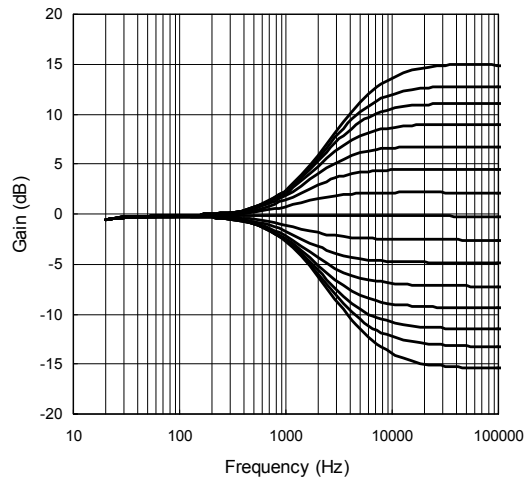

Gain vs Frequency (TONE)

V+=9V, Vin=0.1Vrms, TONE Gain=+14dB, -14dB

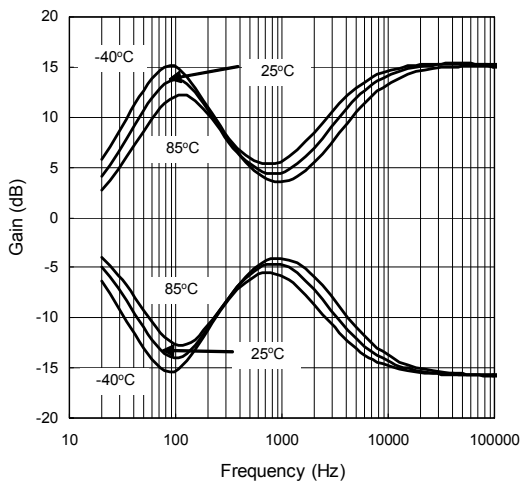

Gain vs Frequency (eala)

V+=9V, Vin(Ach)=0.1Vrms, Vout=Ach, Ta=25°C

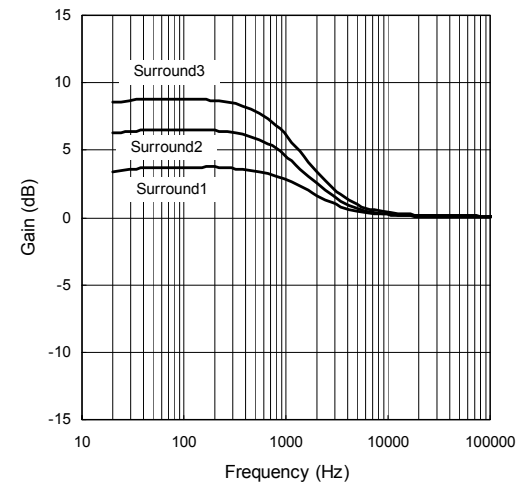

Gain vs Frequency (eala)

V+=9V, Vin(Ach)=0.1Vrms, Vout=Bch, Ta=25°C

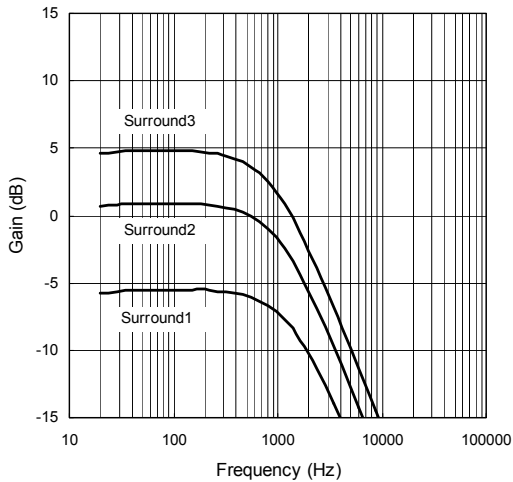

Gain vs Frequency (eala)

V+=9V, Vin(Ach)=0.1Vrms, Surround level=Surround3

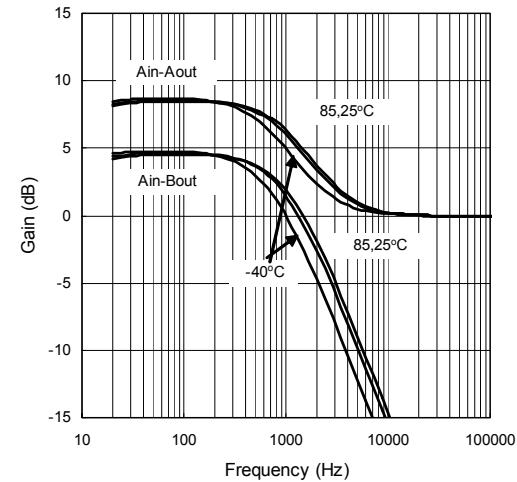

[CAUTION]

The specifications on this databook are only given for information, without any guarantee as regards either mistakes or omissions. The application circuits in this databook are described only to show representative usages of the product and not intended for the guarantee or permission of any right including the industrial rights.