

Pushbutton Interface EVR

■ GENERAL DESCRIPTION

The NJU7394 is a pushbutton interface electronic volume.

It includes a electronic volume controller with differential input, attenuator function, some indicator and a stand-by function (Power-saving mode).

The NJU7394 has also built-in push button interface for its volume UP/DOWN controls and power ON/OFF controls - making application possible without the use of micro-controller.

The NJU7394 is suitable for low power application and also for application without micro-controller such as mobile audio player and cradle speaker for mobile game.

■ PACKAGE OUTLINE



NJU7394VC3

■ FEATURES

- Operating Voltage +2.7 to +5.5V
- Low operating current 2mA typ. (Active mode)
1µA typ. (stand-by mode)
- Pop-noise reduction
- Quasi-differential input
- Pushbutton interface EVR +6 to -62dB, MUTE
- Adjustable initial Volume -6dB, -10dB, -14dB, -18dB
- Attenuator / Soft MUTE Function -10dB, -15dB, -20dB, MUTE
- CMOS Technology
- Package Outline SSOP20-C3

■ BLOCK DIAGRAM

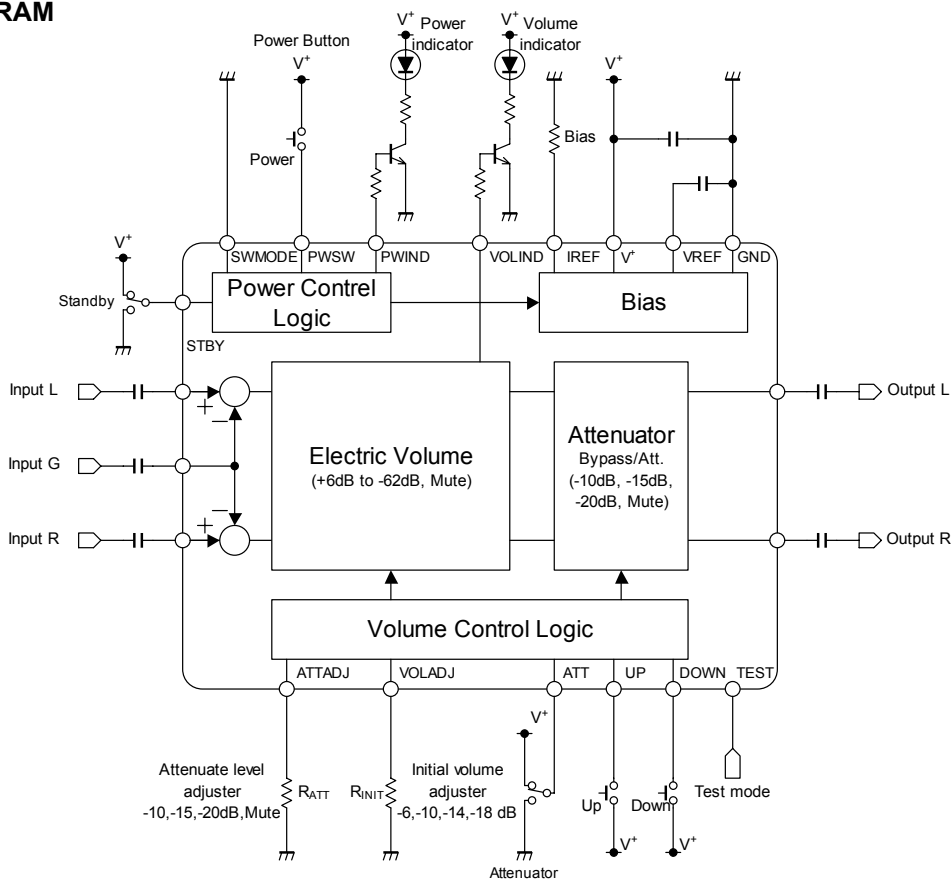

NJU7394

■ PIN CONFIGURATION

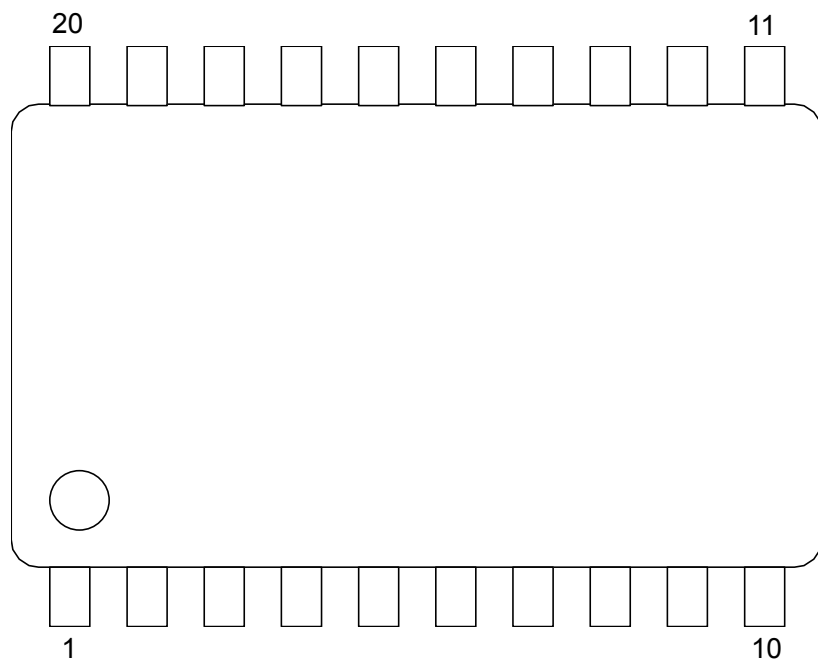

No.	Symbol	Function	No	Symbol	Function
1	INL	Lch Input	11	VOLIND	Volume Indicator
2	ING	Common Input	12	PWIND	Power Indicator
3	INR	Rch Input	13	VOLADJ	Initial Volume Adjustor
4	SWMODE	Control Mode Setting	14	ATTADJ	Attenuator Adjustor
5	STBY	Standby Setting	15	V+	Power Supply
6	ATT	Attenuator Setting	16	GND	Ground
7	PWSW	Power Switch	17	IREF	Reference Current
8	UP	Volume Up Switch	18	OUTR	Rch Output
9	DOWN	Volume Down Switch	19	VREF	Reference Voltage
10	TEST	Test Terminal	20	OUTL	Lch Output

■ ABSOLUTE MAXIMUM RATING (Ta=25°C)

PARAMETER	SYMBOL	RATING	UNIT
Power Supply Voltage	V ⁺	+7	V
Power Dissipation	P _D	540 ^{*1)}	mW
Maximum Input Voltage	V _{IMAX}	0 to V ⁺ *2)	V
Operating Temperature Range	Topr	-40 to +85	°C
Storage Temperature Range	Tstg	-40 to +125	°C

*1) EIA/JEDEC STANDARD Test board (76.2x114.3x1.6mm, 2layer, FR-4) mounting

*2) Don't apply the input voltage that exceeds supply voltage.

■ ELECTRICAL RECOMMENDED OPERATING CONDITION (Ta=25°C)

PARAMETER	SYMBOL	TEST CONDITION	MIN.	TYP.	MAX.	UNIT
Operating Voltage	V ⁺	-	2.7	3.3	5.5	V

■ ELECTRICAL CHARACTERISTICS

●DC CHARACTERISTICS (Ta=25°C, V⁺=3.3V, unless otherwise specified)

PARAMETER	SYMBOL	TEST CONDITION	MIN.	TYP.	MAX.	UNIT
Operating Current	I _{DD1}	No Signal, Active	-	2.0	3.0	mA
	I _{DD2}	No Signal, Standby ^{*3)}	-	0.1	1.0	μA
Reference Voltage	V _{REF}	No signal	1.5	1.65	1.8	V

*3) In case of the voltage of each terminal SWMODE, STBY, ATT, PWSW, UP, DOWN and TEST is "L"=0V.

●AC CHARACTERISTICS

(Ta=25°C, V⁺=3.3V, V_{IN}=500mVrms, f=1kHz, ATT: OFF, VOL: 6dB, unless otherwise specified)

PARAMETER	SYMBOL	TEST CONDITION	MIN.	TYP.	MAX.	UNIT
Maximum Input Voltage	V _{IM}	THD=1% BW=400Hz-30kHz	500	550	-	mVrms
Output Noise Voltage 1	V _{NO1}	Rg=0Ω, A-weighted	-	-100 (10)	-94 (20)	dBV (μVrms)
Output Noise Voltage 2	V _{NO2}	Rg=0Ω, A-weighted VOL=-62dB	-	-100 (10)	-94 (20)	dBV (μVrms)
Total Harmonic Distortion	THD+N	V _{IN} =250mVrms BW=400Hz-30kHz	-	0.05	0.1	%
Maximum Gain	G _{VMAX}		5.0	6.0	7.0	dB
Initial Volume 1	G _{VINIT1}	Power-on state R _{INIT} =0Ω	-8.0	-6.0	-4.0	dB
Initial Volume 2	G _{VINIT2}	Power-on state R _{INIT} =47kΩ	-12.0	-10.0	-8.0	dB
Initial Volume 3	G _{VINIT3}	Power-on state R _{INIT} =100kΩ	-16.0	-14.0	-12.0	dB
Initial Volume 4	G _{VINIT4}	Power-on state R _{INIT} =OPEN	-20.0	-18.0	-16.0	dB
Maximum Attenuate level	G _{V-62}	VOL=-62dB BW=400Hz-30kHz	-64	-62	-60	dB
Mute Level	Mute	VOL=MUTE BW=400Hz-30kHz	-	-90	-84	dB

NJU7394

PARAMETER	SYMBOL	TEST CONDITION	MIN.	TYP.	MAX.	UNIT
ATT Level 1	G_{VATT1}	ATT:ON $R_{ATT}=0\Omega$	-12.0	-10.0	-8.0	dB
ATT Level 2	G_{VATT2}	ATT:ON $R_{ATT}=47k\Omega$	-17.0	-15.0	-13.0	dB
ATT Level 3	G_{VATT3}	ATT:ON $R_{ATT}=100k\Omega$	-22.0	-20.0	-18.0	dB
ATT Mute Level	G_{VATT4}	ATT:ON, $R_{ATT}=OPEN$ BW=400Hz-30kHz	-	-100	-90	dB
Channel Balance	G_{CB}		-1.0	0.0	1.0	dB
Channel Separation	CS	$R_g=0\Omega$ BW=400Hz-30kHz	80	90	-	dB

● **Indicator Output Block** ($T_a=25^\circ C$, $V^+=3.3V$, unless otherwise specified)

PARAMETER	SYMBOL	TEST CONDITION	MIN.	TYP.	MAX.	UNIT
High Output Voltage	V_{OH}	$I_{SOURCE}=1mA$ (pin 11, pin 12)	$V^+*0.8$	-	V^+	V
Low Output Voltage	V_{OL}	$I_{SINK}=1mA$ (pin 11, pin 12)	0	-	$V^+*0.2$	V

● **Control Block** ($T_a=25^\circ C$, $V^+=3.3V$, unless otherwise specified)

PARAMETER	SYMBOL	TEST CONDITION	MIN.	TYP.	MAX.	UNIT
High Input Voltage	V_{IH}	pin4, pin5, pin6, pin7, pin8, pin9	$V^+*0.8$	-	V^+	V
Low Input Voltage	V_{IL}	pin4, pin5, pin6, pin7, pin8, pin9	0	-	$V^+*0.2$	V
Pull-Up Resistance	R_{PULLUP}		-	100	-	$k\Omega$
Mode Resistance range 1/4	R_{MODE1}	pin 13, pin 14	0	-	20	$k\Omega$
Mode Resistance range 2/4	R_{MODE2}	pin 13, pin 14	40	-	60	$k\Omega$
Mode Resistance range 3/4	R_{MODE3}	pin 13, pin 14	90	-	110	$k\Omega$
Mode Resistance range 4/4	R_{MODE4}	pin 13, pin 14	150	-	∞	$k\Omega$
Pulse Distinction Time			15	20	25	ms
Auto Increment Distinction Time			0.8	1	1.2	S
Auto Increment cycle			133	167	200	ms

■ TERMINAL DESCRIPTION

PIN NO.	SYMBOL	FUNCTION	EQUIVALENT CIRCUIT	TERMINAL DC VOLTAGE
1 3	INL INR	Lch Input Rch Input		$V^+/2$
2	ING	Common Input		$V^+/2$
4 5 6	SWMODE STBY ATT	Control Mode Setting Standby Setting Attenuator Setting		It depends on a mode setting.
7 8 9 10	PWSW UP DOWN TEST	Power Switch Volume Up Switch Volume Down Switch Test Terminal		0V

NJU7394

PIN NO.	SYMBOL	FUNCTION	EQUIVALENT CIRCUIT	TERMINAL DC VOLTAGE
11 12	VOLIND PWIND	Volume Indicator Power Indicator		It depends on a mode setting.
13 14	VOLADJ ATTADJ	Initial Volume Adjustor Attenuator Adjustor		It depends on a mode setting.
15	V+	Power Supply		V ⁺
16	GND	Ground		0V

PIN NO.	SYMBOL	FUNCTION	EQUIVALENT CIRCUIT	TERMINAL DC VOLTAGE
17	IREF	Reference Current		1.2V
18 20	OUTR OUTL	Rch Output Lch Output		$V^+/2$ $V^+/2$
19	VREF	Reference Voltage		$V^+/2$

NJU7394

■ PIN DESCRIPTION

SWMODE (pin 4)

PIN CONDITION	FUNCTION
L	PWSW: Momentary SW mode.
H	PWSW: Toggle SW mode.

Momentary SW mode data format

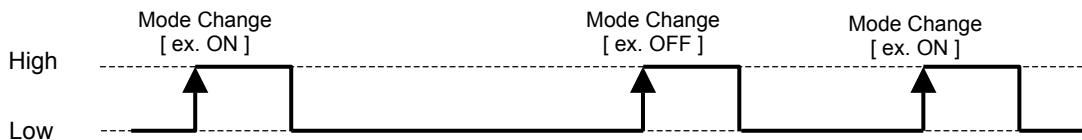

Toggle SW mode data format

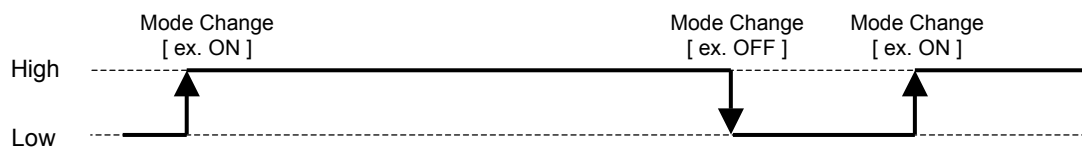

STBY (pin 5)

●Toggle SW Mode

PIN CONDITION	FUNCTION
L	When SWMODE and PWSW are Low, IC becomes a standby mode.
H	When PWSW is High, IC becomes active mode.

* The "Momentary SW mode" does not support.

ATT (pin 6)

●Toggle SW Mode

PIN CONDITION	FUNCTION
L	Attenuator: OFF
H	Attenuator: ON

* The "Momentary SW mode" does not support.

PWSW (pin 7)

●Momentary SW mode setting

PIN CONDITION	FUNCTION
OPEN(L)→H	System status is changed to active mode and standby mode alternately.
H→OPEN(L)	No change.

●Toggle SW mode setting

PIN CONDITION	FUNCTION
H	Active mode
OPEN(L)	Standby Mode.

UP (pin 8)

•Momentary SW mode setting

PIN CONDITION	FUNCTION
OPEN(L)→H	Volume setting is increased 1 step. Long push increase volume setting continuously.
H→OPEN(L)	No change.

* The "Toggle SW mode" does not support.

DOWN (pin 9)

•Momentary SW mode setting

PIN CONDITION	FUNCTION
OPEN(L)→H	Volume setting is decreased 1 step. Long push decrease volume setting continuously.
H→OPEN(L)	No change.

* The "Toggle SW mode" does not support.

TEST (pin 10)

PIN CONDITION	FUNCTION
L	Normal operation mode
H	Test mode. Do not use for normal operation.

VOLADJ (pin 13)

CONNECTED RESISTANCE	FUNCTION
0Ω to 20kΩ	Volume initial value: -6dB
40Ω to 60kΩ	Volume initial value: -10dB
90kΩ to 110kΩ	Volume initial value: -14dB
150kΩ to OPEN	Volume initial value: -18dB

ATTADJ (pin 14)

CONNECTED RESISTANCE	FUNCTION
0Ω to 20kΩ	Attenuator initial value: -10dB
40Ω to 60kΩ	Attenuator initial value: -15dB
90kΩ to 110kΩ	Attenuator initial value: -20dB
150kΩ to OPEN	Mute

NJU7394

■CONTROL DATA

●INITIAL CONDITION (POWER ON)

FUNCTION	TERMINAL	CONDITION
Power	Pin 7	Standby
Volume	Pin 8, Pin 9	-6dB, -10dB, -14dB, -18dB

●Volume gain step setting

Step No.	Volume [dB]
0	MUTE
1	-62
2	-58
3	-54
4	-50
5	-46
6	-42
7	-39
8	-36
9	-33
10	-30
11	-28
12	-26
13	-24
14	-22
15	-20
16	-18^(*)
17	-16
18	-14^(*)
19	-12
20	-10^(*)
21	-8
22	-6^(*)
23	-4
24	-2
25	0
26	+1
27	+2
28	+3
29	+4
30	+5
31	+6

^(*) Initial Setting

■ TIMING CHART (Momentary SW mode)

● Standby release (Standby mode → Active mode)

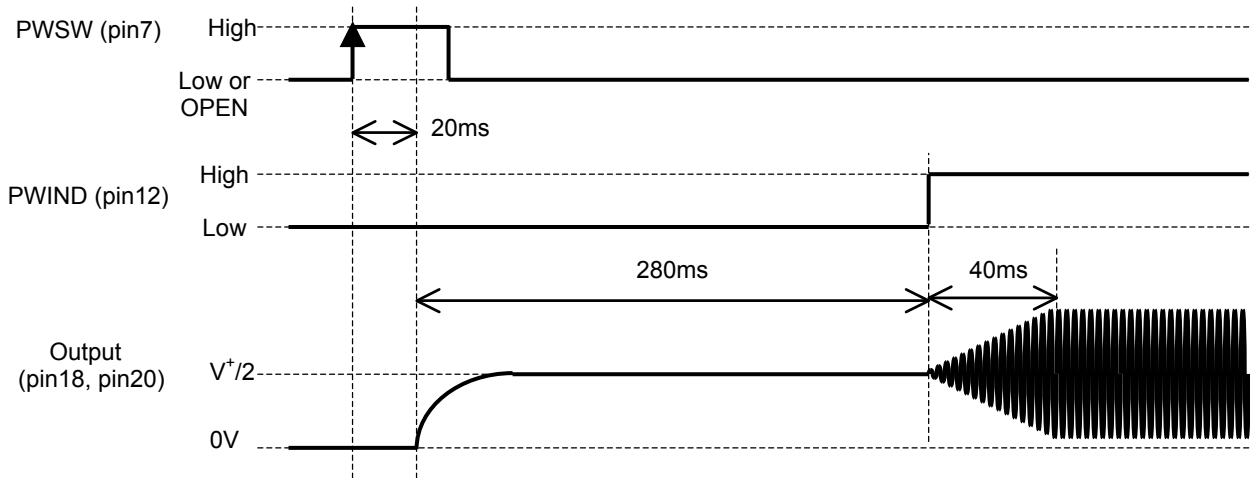

● Standby (Active mode → Standby mode)

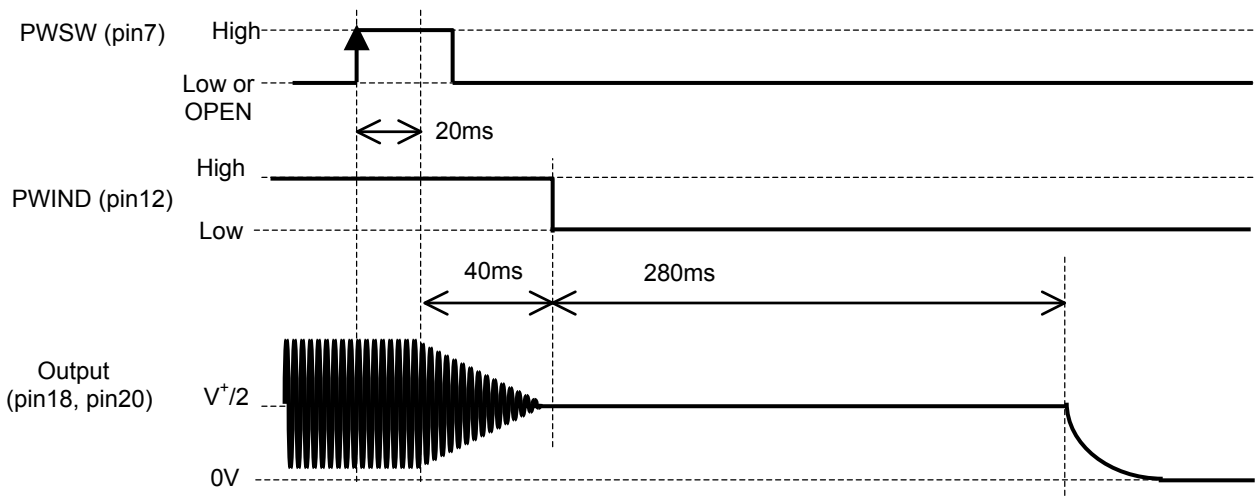

NJU7394

■ TIMING CHART (Toggle SW mode)

● Standby release (Standby mode → Active mode)

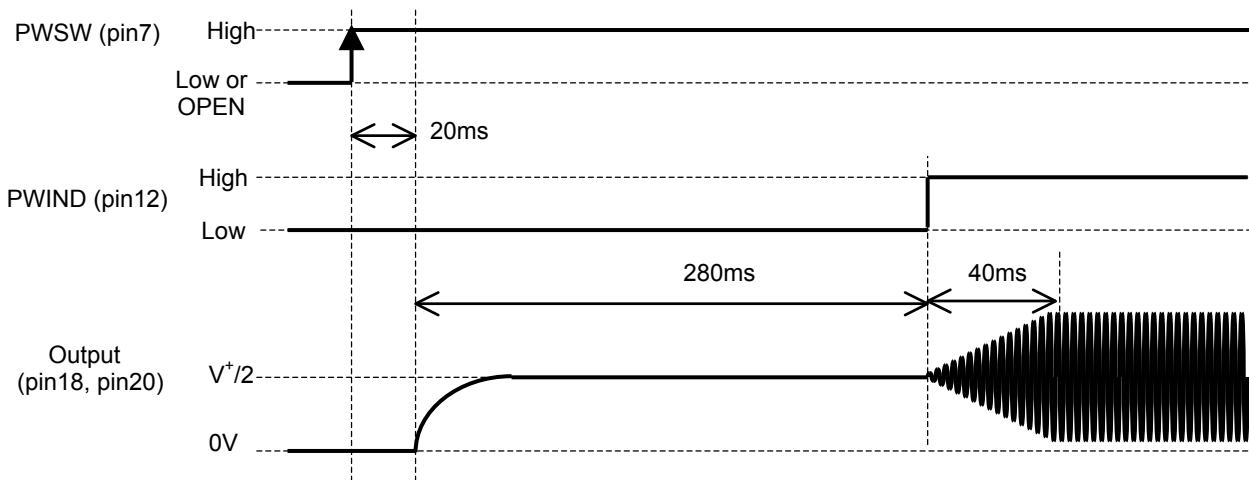

● Standby (Active mode → Standby mode)

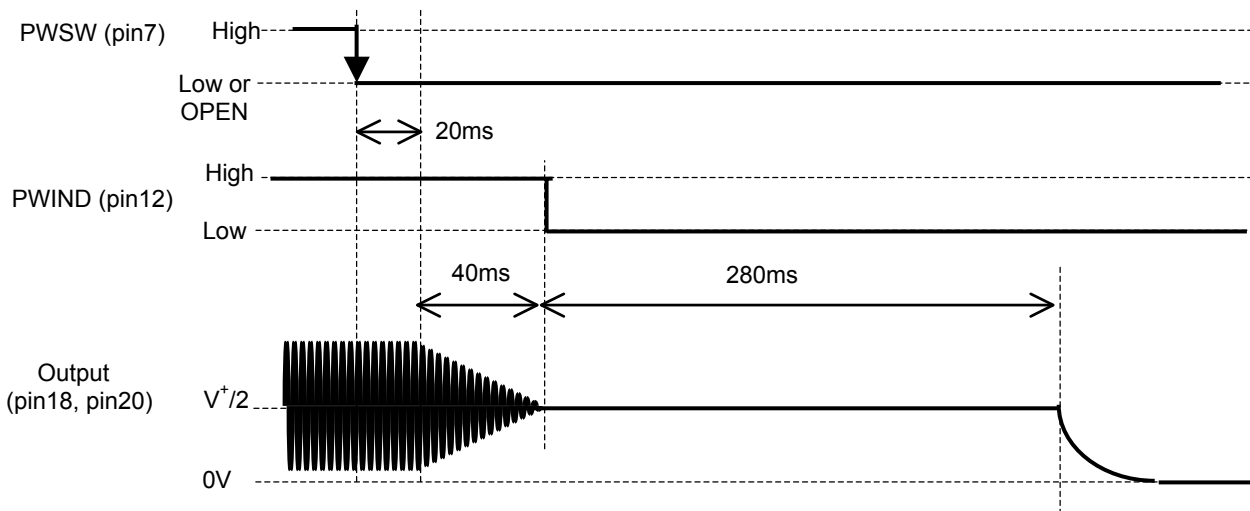

■ TIMING CHART (Volume UP/DOWN control)

1. Recognition condition of Volume UP/DOWN push button I/F

1-a.) The Volume UP/(DOWN) recognizes the data-command to the case that the DOWN(UP) button has not been pushed, besides that the UP(DOWN) button is pushed for the longer time than the "Pulse Distinction Time: 20ms".

1-b.) The Volume UP/(DOWN) recognizes the data-command to the case that the UP(DOWN) button has pushed earlier than the DOWN(UP) button, besides the UP(DOWN) button is pushed for the longer time than the "Pulse Distinction Time: 20ms".

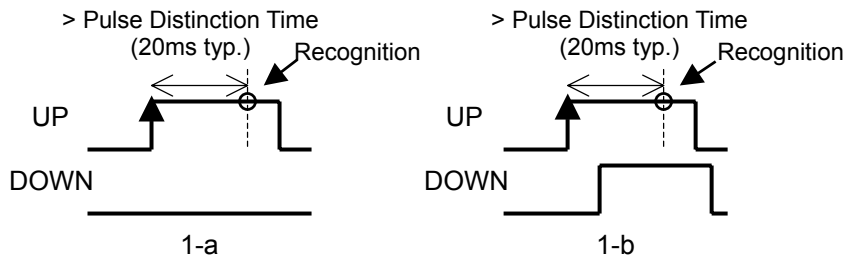

2. Invalidity condition of Volume UP/DOWN push button I/F

2-a.) The Volume UP/(DOWN) **does NOT** recognize the data-command to the case that the UP(DOWN) button has pushed for the shorter time than the "Pulse Distinction Time: 20ms". (The Chattering prevention function operates.)

2-b.) The Volume UP/(DOWN) **does NOT** recognize the data-command to the case that the UP(DOWN) button has pushed for the shorter time than the "Pulse Distinction Time: 20ms" after released button. (The Chattering prevention function operates.)

2-c.) The Volume UP/(DOWN) **does NOT** recognize the data-command to the case that the UP(DOWN) button has pushed before releasing DOWN(UP) button.

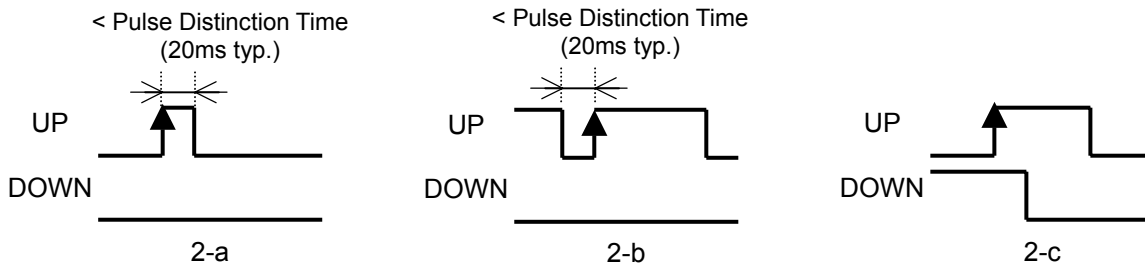

■ TIMING CHART (Volume UP/DOWN control)

3. Start condition of Volume UP/DOWN Auto increment function

3-a.) The Auto increment of volume UP(DOWN) is started to the case that the DOWN(UP) button has not been pushed, besides that the UP(DOWN) button is pushed for the longer time than the "Auto increment Distinction Time: 1s".

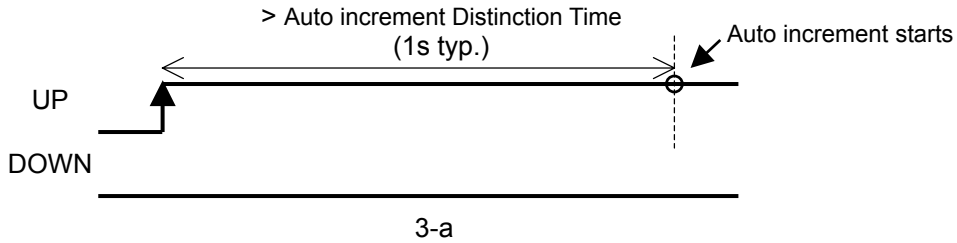

4. Stop condition of Volume UP/DOWN Auto increment function

4-a.) The Auto increment of volume UP(DOWN) is stopped to the case that the UP(DOWN) button has released for the longer time than the "Pulse Distinction Time: 20ms" for the Auto increment period.

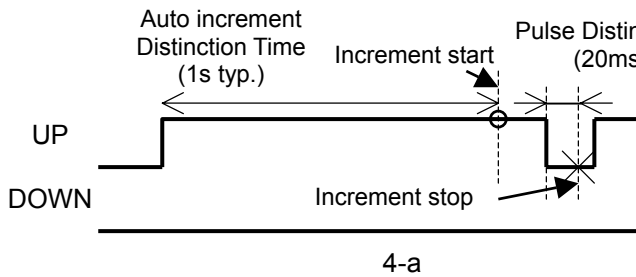

4-b.) The Auto increment of volume UP(DOWN) is stopped to the case that the DOWN(UP) button has pushed for the Auto increment period.

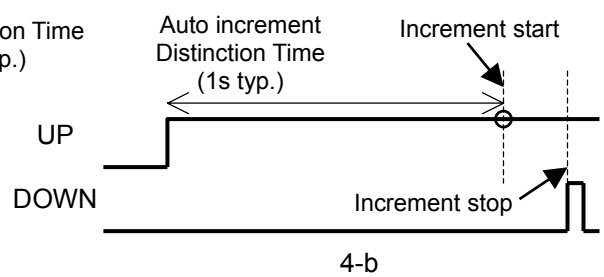

APPLICATION CIRCUIT

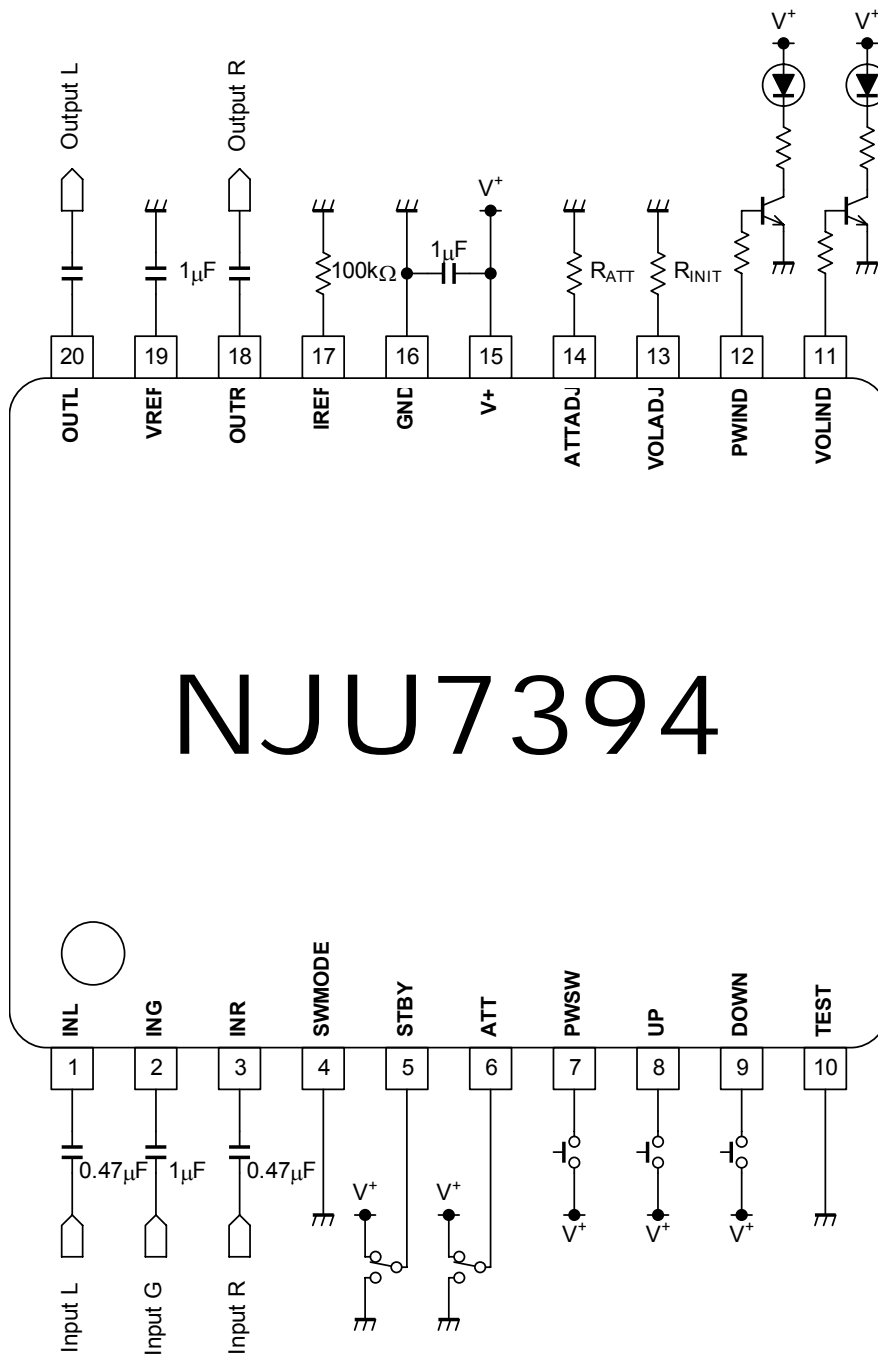

[CAUTION]

The specifications on this databook are only given for information, without any guarantee as regards either mistakes or omissions. The application circuits in this databook are described only to show representative usages of the product and not intended for the guarantee or permission of any right including the industrial rights.