

Analog Signal Input Monaural Filter Less 3.0W Class-D Amplifier

■GENERAL DESCRIPTION

The **NJU8759** is an analog signal input monaural filterless class-D power amplifier. Operating voltage is 1.8V to 5.5V. The **NJU8759** is capable of driving 3W at 5V into 4ohms without external LC low-pass filters. The **NJU8759** incorporates BTL amplifier, which eliminate AC coupling capacitors. The **NJU8759** features high power-efficiency by class-D operation, and is suited for security equipment, portable set with speaker, PC, etc.

■Package



NJU8759WLC1

■FEATURES

- Operating Voltage +1.8 to +5.5 V($3.6\Omega \leq R_L$)
+2.0 to +5.5 V($3.4\Omega \leq R_L < 3.6\Omega$)
3.0 W (5 V, 4 Ω)
- Output power
- No output filters
- Built-in Pop noise reduction(Turn on/Turn off)
- Built-in Short Protector, Thermal Shut Down Function, Under Voltage Lock Out Function
- CMOS Technology
- Package Outline WCSP9(1.45mmX1.45mm)

■Block Diagram

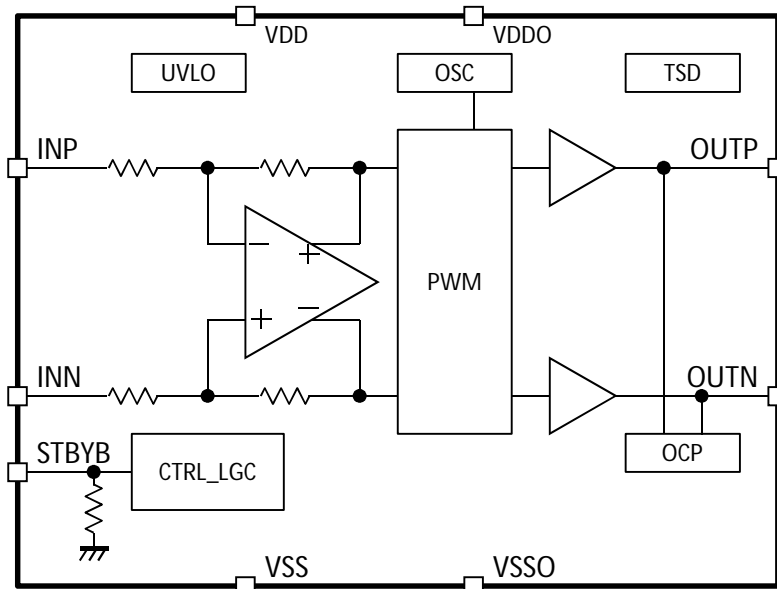

■PIN DESCRIPTION

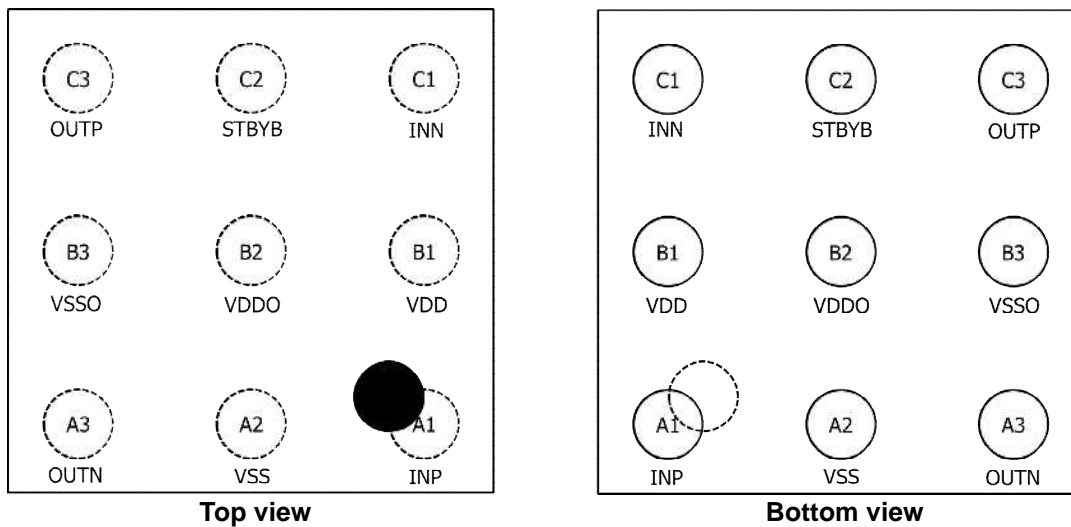

No.	SYMBOL	FUNCTION
A1	INP	Positive input
A2	VSS	Analog GND
A3	OUTN	Negative output
B1	VDD	Power supply
B2	VDDO	Output power supply
B3	VSSO	Power GND
C1	INN	Negative input
C2	STBYB	Standby control
C3	OUTP	Positive output

■ABSOLUTE MAXIMUM RATINGS (Ta=25 °C)

PARAMETER	SYMBOL	RATING		UNIT
Supply Voltage	V ⁺	7.0		V
Power Dissipation	P _{D2}	Mounted on two-layer board	640 ^{*1)}	mW
	P _{D4}	Mounted on four-layer board	1200 ^{*1)}	mW
Thermal Resistance	θ _{ja2}	Mounted on two-layer board	156.6 ^{*1)}	°C/W
	θ _{ja4}	Mounted on four-layer board	83.4 ^{*1)}	°C/W
Input Voltage	V _{IMAX}	0 to V ⁺		V
Operating Temperature1 (3.6Ω≤R _L)	Topr1	-40 to +85		°C
Operating Temperature2 (3.4Ω≤R _L <3.6Ω)	Topr2	-40 to +80		°C
Storage Temperature	Tstg	-40 to +125		°C
Load Resistance		≥3.4		Ω

*1) Mounted on 2-layer/ 4-layer board based on EIA/JEDEC. Applying a thermal via hole mounted on 4-layer board.

■ ELECTRICAL CHARACTERISTICS

DC CHARACTERISTICS (Ta=25°C, V⁺=3.6V)

PARAMETER	SYMBOL	CONDITIONS	MIN	TYP	MAX	UNIT
Supply Voltage1	V ⁺¹	VDD=VDDO=V ⁺ VSS=VSSO=GND (3.6Ω<=R _L)	1.8	3.6	5.5	V
Supply Voltage2	V ⁺²	VDD=VDDO=V ⁺ VSS=VSSO=GND (3.4Ω<=R _L <3.6Ω)	2.0	3.6	5.5	V
Operating Current (Standby)	I _{ST}		-	-	1.0	μA
Operating Current	I _Q		-	2.7	-	mA
UVLO Detect Voltage	V _{DDDET}		1.1	1.4	1.7	V
UVLO Hysteresis Voltage	V _{DDHYS}		-	0.05	-	V
Digital Input Voltage	V _{IH}		1.5	-	VDD	V
	V _{IL}		0	-	0.3	V
Pull Down Resistance	R _{DWN}	STBYB Terminal	-	100	-	kΩ
Input Impedance	R _{IN}	INP, INN Terminal	-	30	-	kΩ
Frequency	F _{OSC}		100	250	395	kHz
Turn On Time	T _{ON}		10	16	40	ms
Turn Off Time	T _{OFF}		10	16	40	ms
Voltage Gain	A _V		17.5	18	18.5	dB
Output OFF Set Voltage Turn ON/Turn OFF	V _{OS}		-20	-	20	mV

AC CHARACTERISTICS

Ta=25°C, V⁺=3.6V, BW=20Hz-20kHz, R_L=8Ω, f=1kHz

PARAMETER	SYMBOL	CONDITION	MIN	TYP	MAX	UNIT
Output Power 1	P _{O8}	V ⁺ =5.0V, THD+N=10%	-	1.7	-	W
Output Power 2	P _{O4}	V ⁺ =5.0V, THD+N=10%, R _L =4	-	3.0	-	W
Output Power Efficiency	η	V ⁺ =5.0V, THD+N=10% R _L =8Ω+33uH	-	93	-	%
THD+N1	THD+N	P _o =0.5W	-	0.05	-	%
THD+N2	THD+N	V ⁺ =5.0V, P _o =1.0 W	-	0.035	-	%
Power Supply Rejection Ratio	PSRR	f _{in} =217Hz, ripple=200mV _{p-p}	-	-55	-	dB
Common Signal Rejection Ratio	CMRR	f _{in} =217Hz, V _{inc} =1V _{p-p}	-	-55	-	dB
Output Noise Voltage	V _{NO}	A-weighting	-	62	-	μV

NJU8759

•Turn on/Turn off Sequence

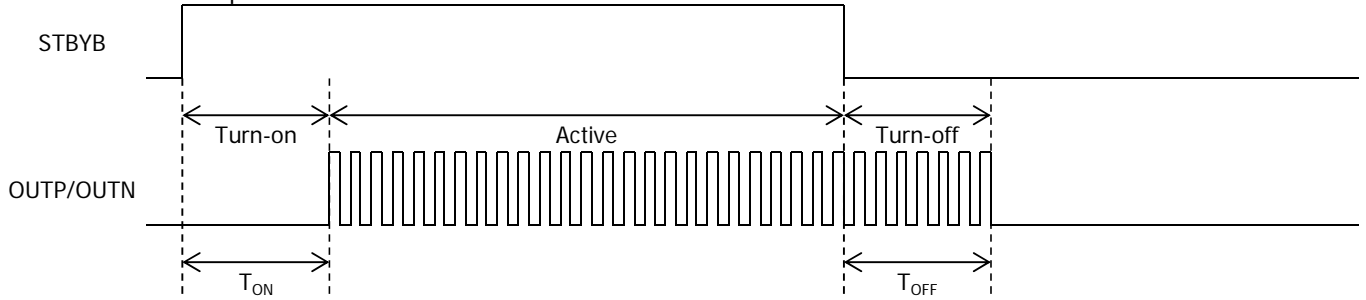

When STBYB is set to "H" in the T_{OFF}, it shifts to Active mode immediately.

•Test system of the output THD+N

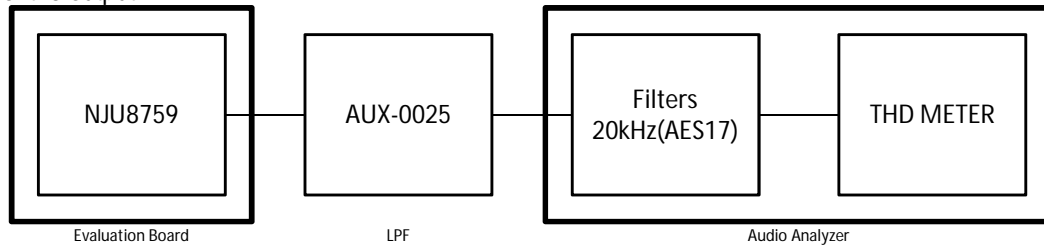

■Application Circuit

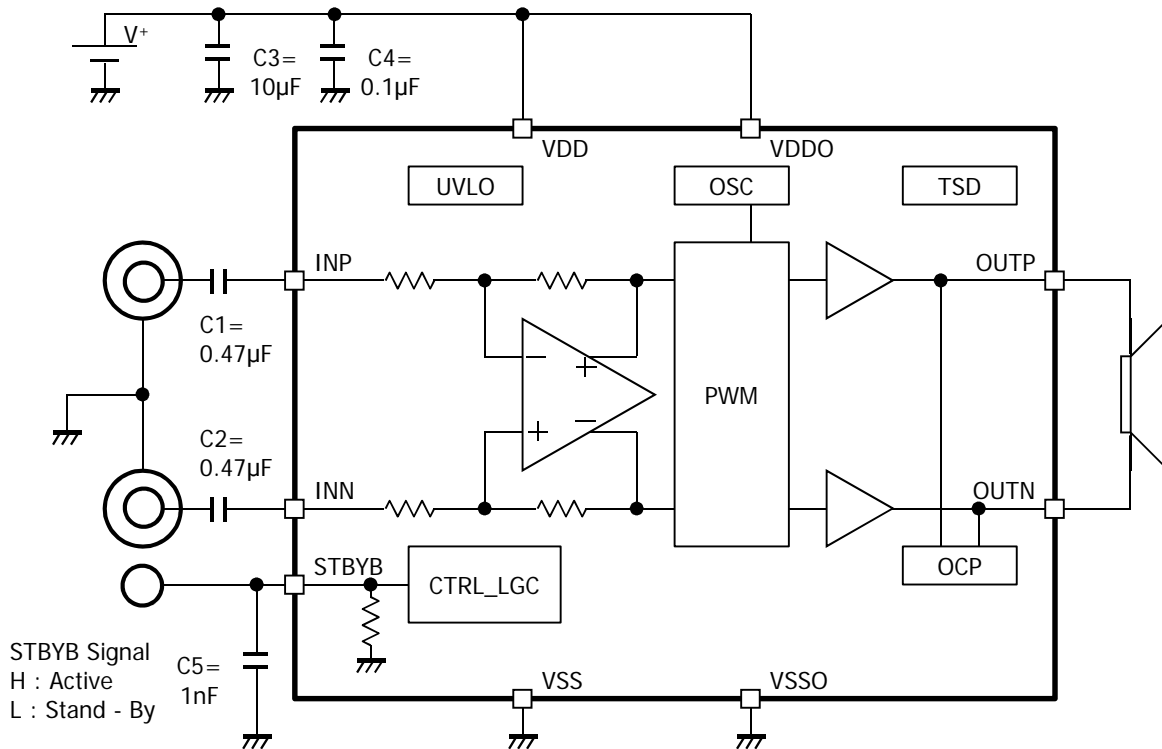

■Package

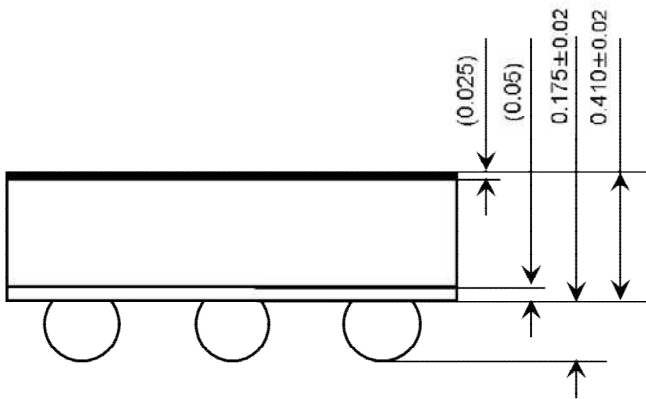
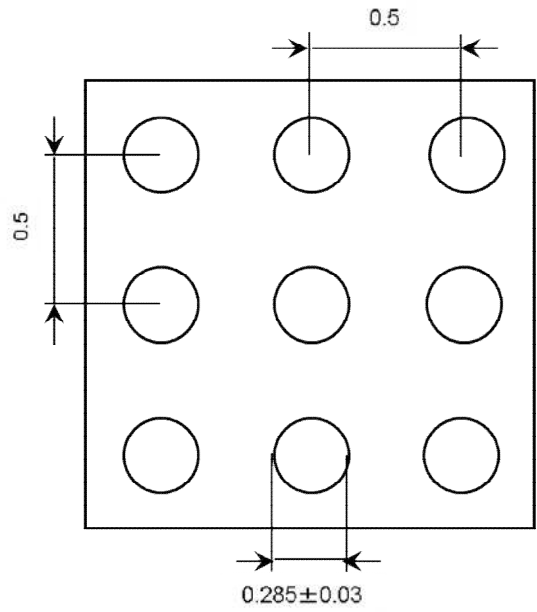
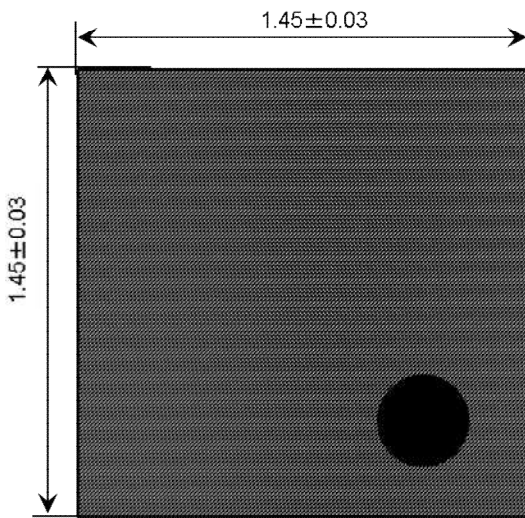

[CAUTION]
 The specifications on this databook are only given for information, without any guarantee as regards either mistakes or omissions. The application circuits in this databook are described only to show representative usages of the product and not intended for the guarantee or permission of any right including the industrial rights.