

3-Band Tone Control IC

■ GENERAL DESCRIPTION

The NJW1119A is a Tone Control IC including 3-Band stereo EQ circuit.

It performs superior audio characteristics such as low distortion and low output noise. All of internal status are controlled by three-wired serial bus. Selectable 4-Chip address is available for using four chips on same serial bus line.

It is suitable for any audio applications.

■ PACKAGE OUTLINE

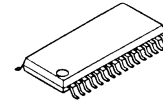

NJW1119AV

■ APPLICATIONS

- AV amplifier/receiver
- Car Audio
- Mini/Micro components

■ FEATURES

- | | |
|---------------------------------|--|
| • Operating Voltage | ± 4.5 to $\pm 7.5V$ |
| • 3-Wired Serial Control | Chip Address Select Function |
| • Low Total Harmonic Distortion | 0.0002% typ. @Tone=OFF |
| • Low Output Noise | -120dB typ. @Tone=OFF |
| • Tone Control | 0 to ± 12 dB/1dB Step (100Hz/1kHz/10kHz) |
| • Bi-CMOS Technology | |
| • Package Outline | SSOP32 |
| • Mute Function | |

■ BLOCK DIAGRAM

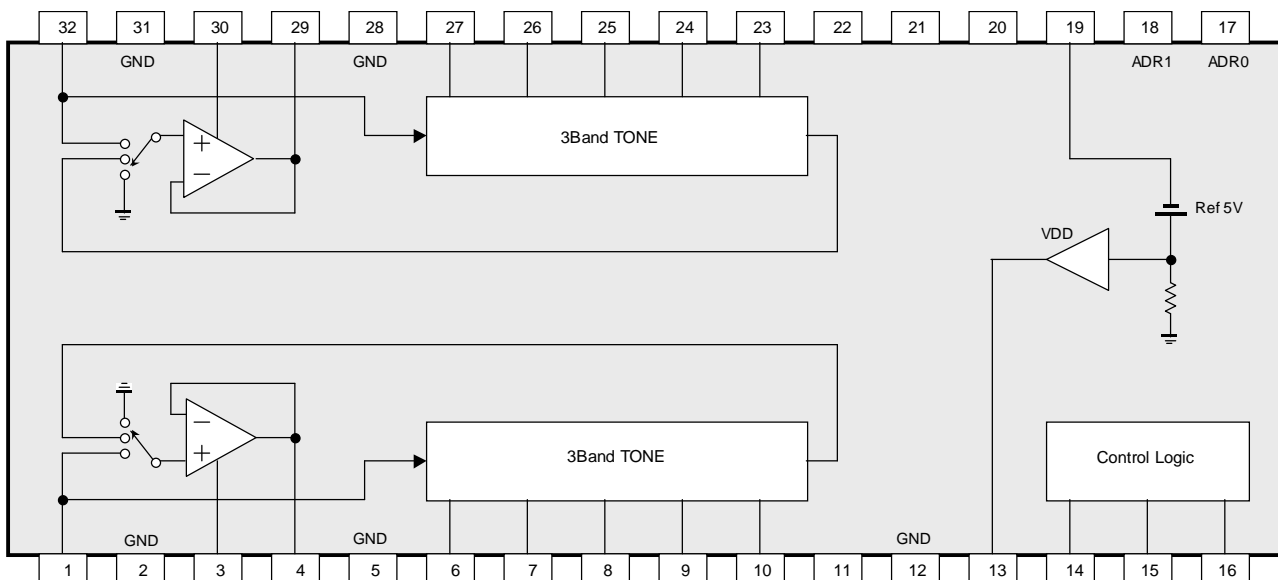

NJW1119A

■PIN CONFIGURATION (SSOP32)

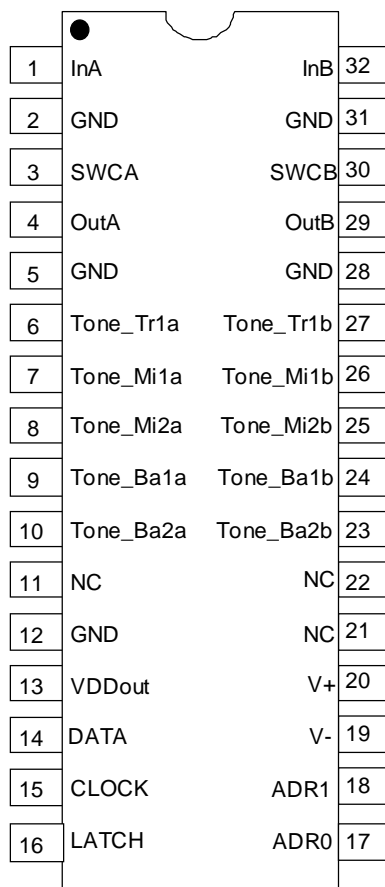

No.	Symbol	Function	No.	Symbol	Function
1	InA	Ach Input	17	ADR0	Chip address setting terminal 0
2	GND	GND Terminal	18	ADR1	Chip address setting terminal 1
3	SWCA	Ach Switching noise rejection capacitor	19	V-	Power Supply Terminal (-)
4	OutA	Ach Output	20	V+	Power Supply Terminal (+)
5	GND	GND Terminal	21	N.C.	No Connection
6	Tone_Tr1a	Ach Treble Filter Terminal 1	22	N.C.	No Connection
7	Tone_Mi1a	Ach Middle Filter Terminal 2	23	Tone_Ba2b	Bch Bass Filter Terminal 2
8	Tone_Mi2a	Ach Middle Filter Terminal 2	24	Tone_Ba1b	Bch Bass Filter Terminal 1
9	Tone_Ba1a	Ach Bass Filter Terminal 1	25	Tone_Mi2b	Bch Middle Filter Terminal 2
10	Tone_Ba2a	Ach Bass Filter Terminal 2	26	Tone_Mi1b	Bch Middle Filter Terminal 1
11	N.C.	No Connection	27	Tone_Tr1b	Bch Treble Filter Terminal 1
12	GND	GND Terminal	28	GND	GND Terminal
13	VDDout	Internal Digital Power Supply output	29	OutB	Bch Output
14	DATA	DATA (3 wire)	30	SWCB	Bch Switching noise rejection capacitor
15	CLOCK	CLOCK (3 wire)	31	GND	GND Terminal
16	LATCH	LATCH (3 wire)	32	InB	Bch Input

■ ABSOLUTE MAXIMUM RATING (Ta=25°C)

PARAMETER	SYMBOL	RATING	UNIT
Power Supply Voltage	V ⁺ /V ⁻	+8/-8	V
Maximum Input Voltage	V _{IM}	V ⁺ /V ⁻ (*)	V
Power Dissipation	P _D	800 NOTE: EIA/JEDEC STANDARD Test board (76.2x114.3x1.6mm, 2layer, FR-4) mounting	mW
Operating Temperature Range	T _{opr}	-40 to +85	°C
Storage Temperature Range	T _{str}	-40 to +125	°C

(*) NOTE: Be careful to use in power supply voltage range

■ RECOMMENDED OPERATING CONDITIONS (Ta=25°C)

PARAMETER	SYMBOL	TEST CONDITION	MIN.	TYP.	MAX.	UNIT
Operating Voltage	V ⁺ /V ⁻	-	±4.5	±7.0	±7.5	V

■ ELECTRICAL CHARACTERISTICS

◆ Power Supply (Ta=25°C, V⁺/V⁻=±7V, R_L=47kΩ)

PARAMETER	SYMBOL	TEST CONDITION	MIN.	TYP.	MAX.	UNIT
Supply Current1	I _{CC}	V ⁺ , No Signal	7	14	21	mA
Supply Current2	I _{EE}	V ⁻ , No Signal	7	14	21	mA
Reference Voltage	V _{REF}	V _{DDOUT}	-2.5	-2.0	-1.5	V

Notes: Any signal must not be inputted on the power "off". It may affect initial condition of DATA CONTROL.

◆ AC CHARACTERISTICS (Ta=25°C, V⁺/V⁻=±7V, R_L=47kΩ)

PARAMETER	SYMBOL	TEST CONDITION	MIN.	TYP.	MAX.	UNIT
Maximum Output Voltage	V _{OM}	f=1kHz, THD=1%, Tone=OFF	9.5 (3.0)	12.0 (4.0)	-	dBV (Vrms)
Voltage Gain	G _V	V _{IN} =2Vrms, f=1kHz, Tone=OFF	-0.5	0	0.5	dB
Voltage Gain Error 1	ΔG _{V1}	V _{IN} =2Vrms, f=1kHz, Ach - Bch Tone=OFF	-0.5	0	0.5	dB
Voltage Gain Error 2	ΔG _{V2}	V _{IN} =2Vrms, f=10kHz, Ach - Bch Tone=ON (Bass=Mid=Treble=0dB)	-0.5	0	0.5	
Mute Level	Mute	V _{IN} =2Vrms, f=1kHz, Mode=Mute, A-weighted	-	-116	-104	dB
Output Noise1	V _{NO1}	Rg=0Ω, A-Weighted, Tone=OFF	-	-120 (1.0)	-110 (3.2)	dBV (μVrms)
Output Noise2	V _{NO2}	Rg=0Ω, A-Weighted, Tone=ON (Bass=Mid=Treble=0dB)	-	-110 (3.2)	-104 (6.3)	
Channel Separation 1	CS1	V _{IN} =2Vrms, f=1kHz, Rg=0Ω, A-Weighted Tone=OFF	-	-100	-90	dB
Channel Separation 2	CS2	V _{IN} =2Vrms, f=1kHz, Rg=0Ω, A-Weighted Tone=ON(Bass=Mid=Treble=0dB)	-	-100	-90	
Channel Separation 3	CS3	V _{IN} =2Vrms, f=20kHz, Rg=0Ω, Tone=ON(Bass=Mid=Treble=0dB)	-	-80	-	

NJW1119A

PARAMETER	SYMBOL	TEST CONDITION	MIN.	TYP.	MAX.	UNIT
Total Harmonic Distortion 1	THD1	$V_{IN}=2V_{rms}$, $f=1kHz$, BW=400Hz-30kHz, Tone=OFF	-	0.0002	-	%
Total Harmonic Distortion 2	THD2	$V_{IN}=2V_{rms}$, $f=20kHz$, Tone=OFF	-	0.002	-	
Total Harmonic Distortion 3	THD3	$V_{IN}=2V_{rms}$, $f=1kHz$, BW=400Hz-30kHz, Tone=ON (Bass=Mid=Treble=0dB)	-	0.002	0.02	
Total Harmonic Distortion 4	THD4	$V_{IN}=2V_{rms}$, $f=20kHz$, Tone=ON (Bass=Mid=Treble=0dB)	-	0.005	-	

BW: Band Width

◆ TONE CHARACTERISTICS (Ta=25°C, $V^+/V^- = \pm 7V$, $R_L=47k\Omega$)

PARAMETER	SYMBOL	TEST CONDITION	MIN.	TYP.	MAX.	UNIT
Treble Flat Gain	G_{VTREB1}	$V_{IN}=2V_{rms}$, $f=10kHz$, Tone= ON, Treble=0dB	-1.5	0	+1.5	dB
Treble Boost Gain	G_{VTREB2}	$V_{IN}=100mV_{rms}$, $f=10kHz$, Tone= ON, Treble=+12dB	+10.5	+12	+13.5	
Treble Cut Gain	G_{VTREB3}	$V_{IN}=100mV_{rms}$, $f=10kHz$, Tone= ON, Treble=-12dB	-13.5	-12	-10.5	
Middle Flat Gain	G_{VMIDD1}	$V_{IN}=2V_{rms}$, $f=1kHz$, Tone= ON, Middle=0dB	-1.5	0	+1.5	
Middle Boost Gain	G_{VMIDD2}	$V_{IN}=100mV_{rms}$, $f=1kHz$, Tone= ON, Middle=+12dB	+10.5	+12	+13.5	
Middle Cut Gain	G_{VMIDD3}	$V_{IN}=100mV_{rms}$, $f=1kHz$, Tone= ON, Middle=-12dB	-13.5	-12	-10.5	
Bass Flat Gain	G_{VBASS1}	$V_{IN}=2V_{rms}$, $f=100Hz$, Tone= ON, Bass=0dB	-1.5	0	+1.5	
Bass Boost Gain	G_{VBASS2}	$V_{IN}=100mV_{rms}$, $f=100Hz$, Tone= ON, Bass=+12dB	+10.5	+12	+13.5	
Bass Cut Gain	G_{VBASS3}	$V_{IN}=100mV_{rms}$, $f=100Hz$, Tone= ON, Bass=-12dB	-13.5	-12	-10.5	

◆ LOGIC CONTROL CHARACTERISTICS (Ta=25°C, $V^+/V^- = \pm 7V$)

PARAMETER	SYMBOL	TEST CONDITION	MIN.	TYP.	MAX.	UNIT
High Level Input Voltage	V_{IH}	DATA, CLOCK, LATCH, ADR0, ADR1 Terminal	2.5	-	V^+	V
Low Level Input Voltage	V_{IL}	DATA, CLOCK, LATCH, ADR0, ADR1 Terminal	0	-	1.5	

■ TERMINAL DESCRIPTION

PIN NO.	SYMBOL	FUNCTION	EQUIVALENT CIRCUIT	TERMINAL DC VOLTAGE
1 32	InA InB	Ach Input Bch Input		0V
2 5 12 28 31	GND	GND Terminal		0V
3 30	SWCA SWCB	Ach Switching noise rejection capacitor Bch Switching noise rejection capacitor		V-(sub) + 0.7V (TONE=OFF)
4 29	OutA OutB	Ach Output Bch Output		0V
6 27	Tone_Tr1a Tone_Tr1b	Ach Treble Filter Terminal 1 Bch Treble Filter Terminal 1		0V

NJW1119A

■ TERMINAL DESCRIPTION

PIN NO.	SYMBOL	FUNCTION	EQUIVALENT CIRCUIT	TERMINAL DC VOLTAGE
7 26	Tone_Mi1a Tone_Mi1b	Ach Middle Filter Terminal 1 Bch Middle Filter Terminal 1		0V
8 25	Tone_Mi2a Tone_Mi2b	Ach Middle Filter Terminal 2 Bch Middle Filter Terminal 2		0V
9 24	Tone_Ba1a Tone_Ba1b	Ach Bass Filter Terminal 1 Bch Bass Filter Terminal 1		0V
10 23	Tone_Ba2a Tone_Ba2b	Ach Bass Filter Terminal 2 Bch Bass Filter Terminal 2		0V

■ TERMINAL DESCRIPTION

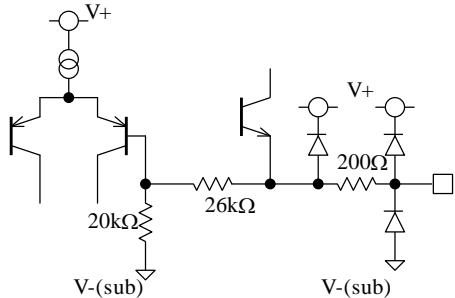
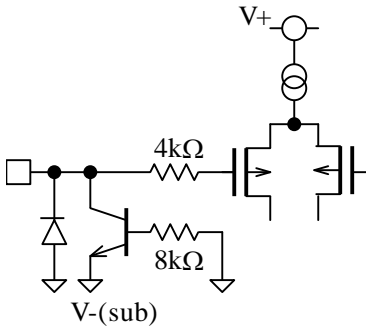
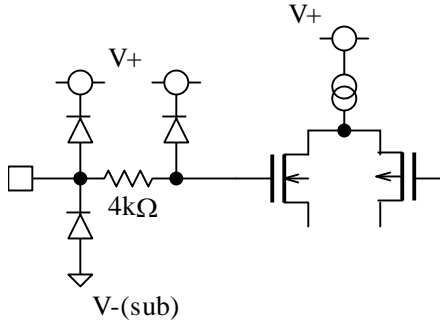
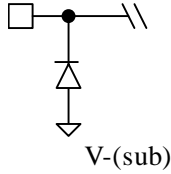
PIN NO.	SYMBOL	FUNCTION	EQUIVALENT CIRCUIT	TERMINAL DC VOLTAGE
13	VDDout	Internal Digital Power Supply output		V-(sub) + 5V
14 15 16	DATA CLOCK LATCH	DATA (3 wire) CLOCK (3 wire) LATCH (3 wire)		-
17 18	ADR0 ADR1	Chip address setting terminal 0 Chip address setting terminal 0		-
20	V+	Power Supply Terminal (+)		V+

NJW1119A

CONTROL DATA FORMAT

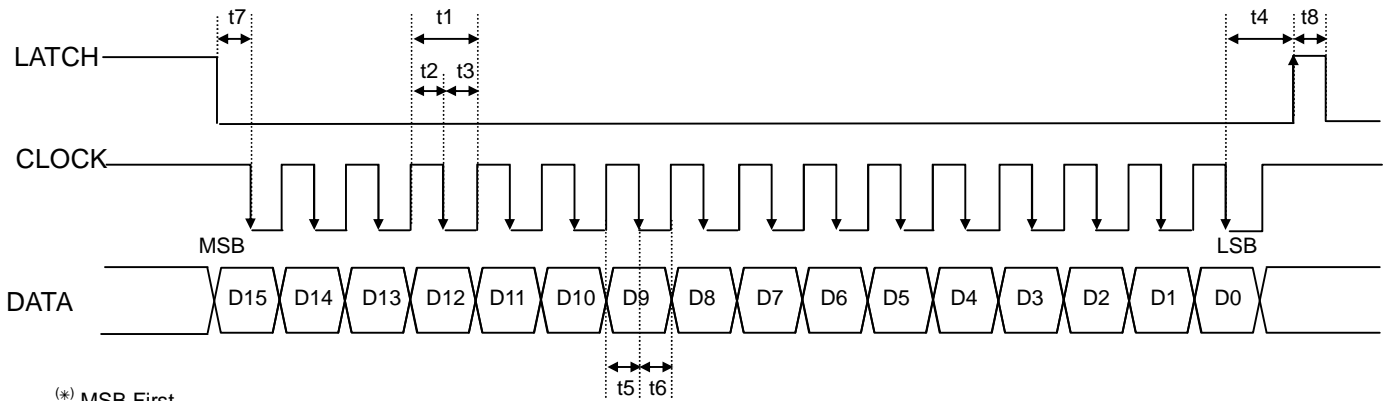

(*) MSB First

SYMBOL	PARAMETER	MIN	TYP	MAX	UNIT
t1	CLOCK Clock Width	4	-	-	μSEC
t2	CLOCK Pulse Width (High)	2	-	-	μSEC
t3	CLOCK Pulse Width (Low)	2	-	-	μSEC
t4	LATCH Rise Hold Time	4	-	-	μSEC
t5	DATA Setup Time	1.6	-	-	μSEC
t6	DATA Hold Time	1.6	-	-	μSEC
t7	CLOCK Setup Time	1.6	-	-	μSEC
t8	LATCH High Pulse Width	1.6	-	-	μSEC

CONTROL DATA

NJW1119A control data is constructed with 16bits.

MSB															LSB
D15	D14	D13	D12	D11	D10	D9	D8	D7	D6	D5	D4	D3	D2	D1	D0
DATA								Select Address				Chip Address			

MSB															LSB
D15	D14	D13	D12	D11	D10	D9	D8	D7	D6	D5	D4	D3	D2	D1	D0
TC/Ba	Ach Treble control				TSWa	Mutea	Don't Care	0	0	0	0	1	1	*	*
MC/Ba	Ach Middle control				Don't Care	Don't Care	Don't Care	0	0	0	1	1	1	*	*
BC/Ba	Ach Bass control				Don't Care	Don't Care	Don't Care	0	0	1	0	1	1	*	*
TC/Bb	Bch Treble control				TSWb	Muteb	Don't Care	0	0	1	1	1	1	*	*
MC/Bb	Bch Middle control				Don't Care	Don't Care	Don't Care	0	1	0	0	1	1	*	*
BC/Bb	Bch Bass control				Don't Care	Don't Care	Don't Care	0	1	0	1	1	1	*	*

* Chip address is set by chip address select terminal (ADR0, ADR1) status.

chip address select terminal		Chip Address			
ADR1	ADR0	D3	D2	D1	D0
L	L	1	1	0	0
L	H	1	1	0	1
H	L	1	1	1	0
H	H	1	1	1	1

■ INITIAL CONDITION

MSB														LSB	
D15	D14	D13	D12	D11	D10	D9	D8	D7	D6	D5	D4	D3	D2	D1	D0
0	0	0	0	0	0	1	0	0	0	0	0	1	1	*	*
0	0	0	0	0	0	0	0	0	0	0	1	1	1	*	*
0	0	0	0	0	0	0	0	0	0	1	0	1	1	*	*
0	0	0	0	0	0	1	0	0	0	1	1	1	1	*	*
0	0	0	0	0	0	0	0	0	1	0	0	1	1	*	*
0	0	0	0	0	0	0	0	0	1	0	1	1	1	*	*

* Chip address is set by chip address select terminal (ADR0,ADR1) status.

■ CONTROL DATA

- ◆ **TC/Ba,TC/Bb** : Treble Cut / Boost for each channel.
- Treble Control** : Gain setting for Treble control for each channel.
- TSWa,TSWb** : Tone Control By-pass Switch for each channel.
- Mutea,Muteb** : Mute Switch for each channel.

D15	D14	D13	D12	D11	D10	D9	D8	D7	D6	D5	D4	D3	D2	D1	D0
TC/Ba	Ach Treble control				TSWa	Mutea	Don't Care	0	0	0	0	Chip Address			
TC/Bb	Bch Treble control				TSWb	Muteb	Don't Care	0	0	1	1	Chip Address			

< TC/Ba,TC/Bb : Treble Cut / Boost >

D15	Setting
0	Cut ^(*)
1	Boost

< Treble Control : Treble Gain >

Data				Cut	Boost
D14	D13	D12	D11		
0	0	0	0	0dB ^(*)	0dB
0	0	0	1	-1dB	1dB
0	0	1	0	-2dB	2dB
0	0	1	1	-3dB	3dB
0	1	0	0	-4dB	4dB
0	1	0	1	-5dB	5dB
0	1	1	0	-6dB	6dB
0	1	1	1	-7dB	7dB
1	0	0	0	-8dB	8dB
1	0	0	1	-9dB	9dB
1	0	1	0	-10dB	10dB
1	0	1	1	-11dB	11dB
1	1	0	0	-12dB	12dB

<TSWa,TSWb : Tone Control By-pass Switch >

D10	Setting
0	Tone Control OFF ^(*)
1	Tone Control ON

<MUTEa,MUTEb : Mute Switch

D9	Setting
0	Mute OFF
1	Mute ON ^(*)

^(*):initial Setting

NJW1119A

◆ **MC/Ba,MC/Bb** : Middle Cut / Boost for each channel
Middle Control : Gain setting for Middle control for each channel.

D15	D14	D13	D12	D11	D10	D9	D8	D7	D6	D5	D4	D3	D2	D1	D0
MC/Ba	Ach Middle control				Don't Care	Don't Care	Don't Care	0	0	0	1	Chip Address			
MC/Bb	Bch Middle control				Don't Care	Don't Care	Don't Care	0	1	0	0	Chip Address			

< MC/Ba,MC/Bb : Middle Cut / Boost >

D15	Setting
0	Cut ^(*)
1	Boost

< Middle Control : Middle Gain >

Data				Cut	Boost
D14	D13	D12	D11		
0	0	0	0	0dB ^(*)	0dB
0	0	0	1	-1dB	1dB
0	0	1	0	-2dB	2dB
0	0	1	1	-3dB	3dB
0	1	0	0	-4dB	4dB
0	1	0	1	-5dB	5dB
0	1	1	0	-6dB	6dB
0	1	1	1	-7dB	7dB
1	0	0	0	-8dB	8dB
1	0	0	1	-9dB	9dB
1	0	1	0	-10dB	10dB
1	0	1	1	-11dB	11dB
1	1	0	0	-12dB	12dB

^(*)initial setting

◆ **BC/Ba,BC/Bb** : Bass Cut / Boost for each channel
Bass Control : Gain setting for Bass control for each channel.

D15	D14	D13	D12	D11	D10	D9	D8	D7	D6	D5	D4	D3	D2	D1	D0
BC/Ba	Ach Bass control				Don't Care	Don't Care	Don't Care	0	0	1	0	Chip Address			
BC/Bb	Bch Bass control				Don't Care	Don't Care	Don't Care	0	1	0	1	Chip Address			

< BC/Ba,BC/Bb : Bass Cut / Boost >

D15	Setting
0	Cut ^(*)
1	Boost

< Bass Control: Bass Gain >

Data				Cut	Boost
D14	D13	D12	D11		
0	0	0	0	0dB ^(*)	0dB
0	0	0	1	-1dB	1dB
0	0	1	0	-2dB	2dB
0	0	1	1	-3dB	3dB
0	1	0	0	-4dB	4dB
0	1	0	1	-5dB	5dB
0	1	1	0	-6dB	6dB
0	1	1	1	-7dB	7dB
1	0	0	0	-8dB	8dB
1	0	0	1	-9dB	9dB
1	0	1	0	-10dB	10dB
1	0	1	1	-11dB	11dB
1	1	0	0	-12dB	12dB

^(*)initial setting

APPLICATION CIRCUIT

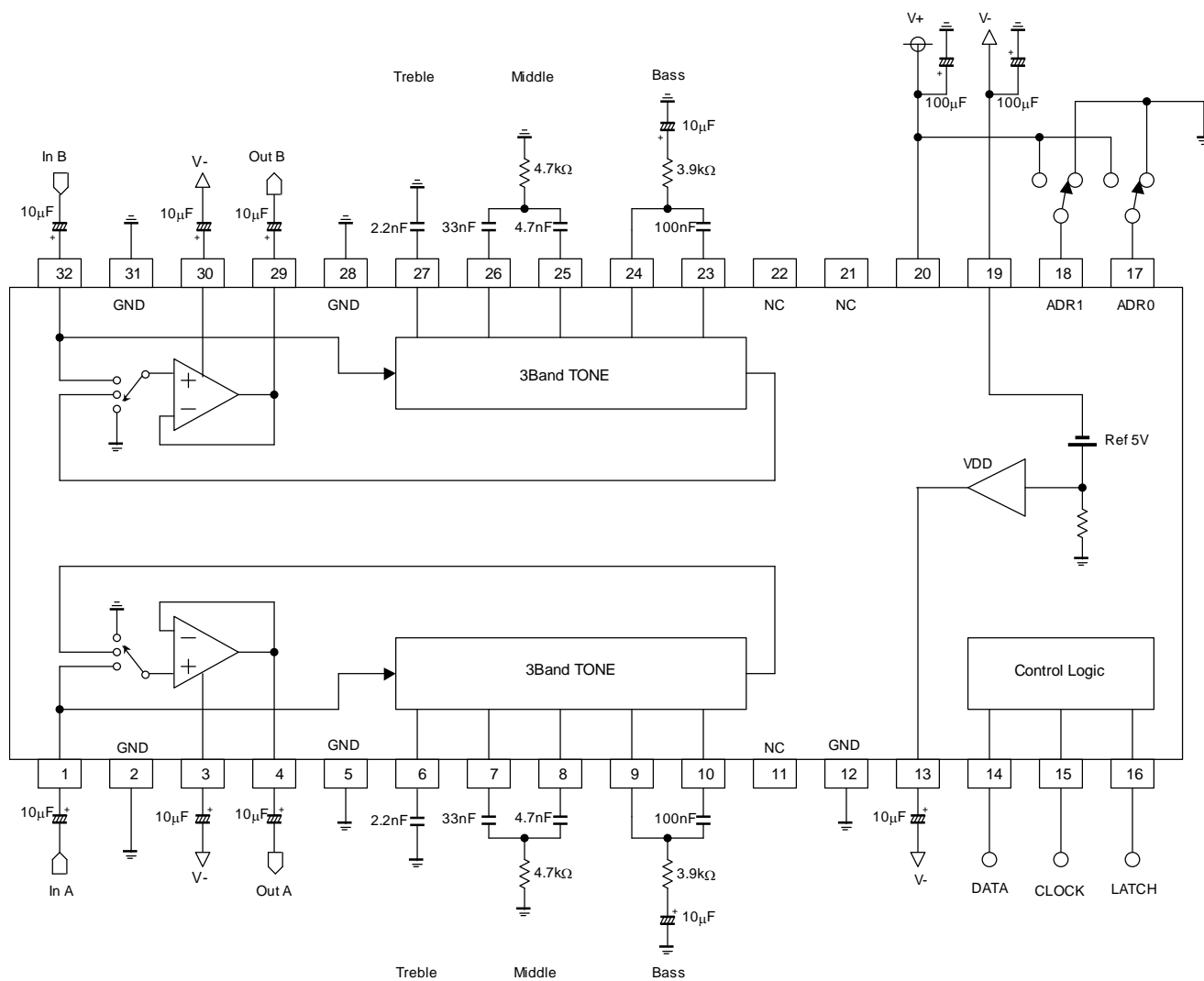

NJW1119A

APPLICATION NOTE

(1) TONE Control

(a) Bass Control

(a-1) Boost

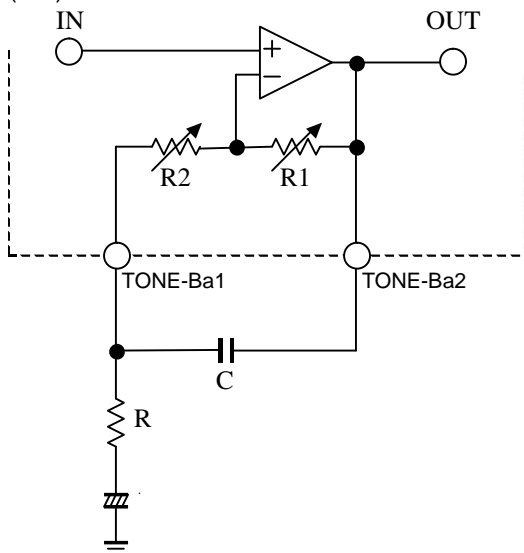

(a-2) Cut

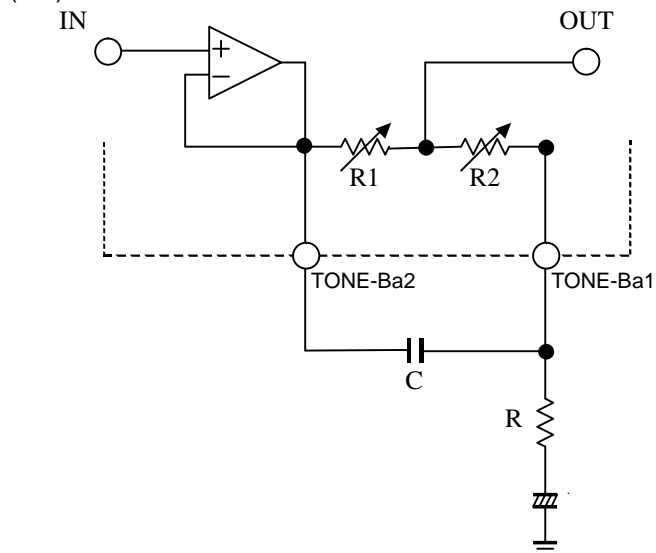

$$f_0 = \frac{R + R2}{2\pi CR(R1 + R2)}$$

$$G_0 = \pm 20 \text{Log} \frac{R + R1 + R2}{R + R2}$$

Table.a-1 : Internal resistance in each Gain.

C=100nF, R=3.9kΩ

Gain	R1	R2
±12dB	29.1kΩ	0.7kΩ
±11dB	27.4kΩ	2.4kΩ
±10dB	25.8kΩ	4kΩ
±9dB	24.05kΩ	5.75kΩ
±8dB	22.2kΩ	7.6kΩ
±7dB	20.25kΩ	9.55kΩ
±6dB	18.15kΩ	11.65kΩ
±5dB	15.85kΩ	13.95kΩ
±4dB	13.3kΩ	16.5kΩ
±3dB	10.45kΩ	19.35kΩ
±2dB	7.35kΩ	22.45kΩ
±1dB	3.9kΩ	25.9kΩ

(b) Middle Control

(b-1) Boost

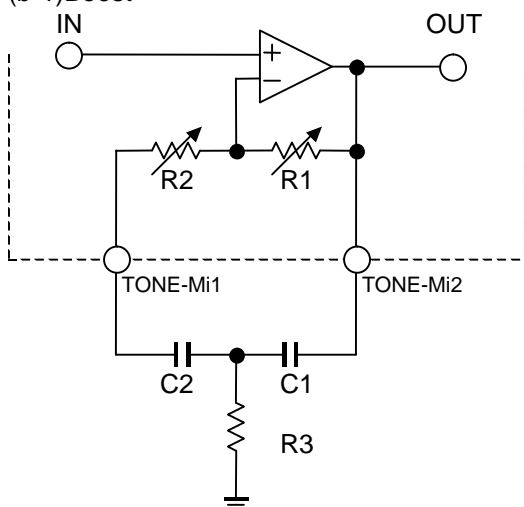

(b-2) Cut

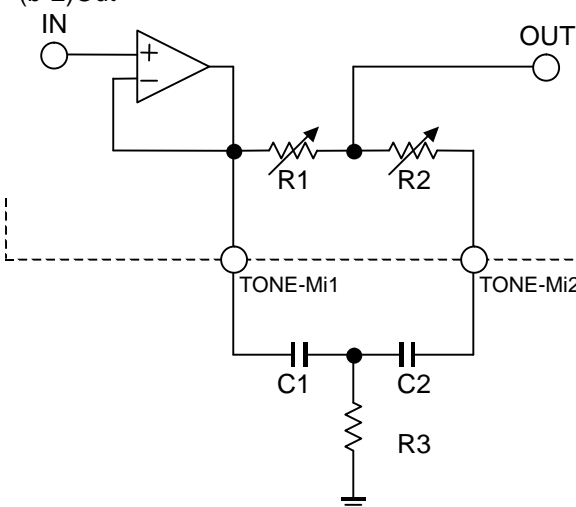

$$f_0 = \frac{1}{2\pi\sqrt{(R1 + R2) \times R3 \times C1 \times C2}}$$

$$Q = \frac{\sqrt{(R1 + R2) \times R3 \times C1 \times C2}}{R2 \times C2 + R3 \times (C1 + C2)}$$

$$G_0 = \pm 20 \text{Log} \frac{(R1 + R2 + R3) \times C2 + R3 \times C1}{C2 \times R2 + (C1 + C2) \times R3}$$

Table.b-1 : Internal resistance in each Gain.

C1=4.7nF, C2=33nF, R3=4.7 kΩ

Gain	R1	R2
±12dB	30.066kΩ	4.567kΩ
±11dB	28.845kΩ	5.788kΩ
±10dB	27.455kΩ	7.178kΩ
±9dB	25.906kΩ	8.727kΩ
±8dB	24.167kΩ	10.466kΩ
±7dB	22.217kΩ	12.416kΩ
±6dB	20.028kΩ	14.605kΩ
±5dB	17.573kΩ	17.06kΩ
±4dB	14.818kΩ	19.815kΩ
±3dB	11.726kΩ	22.907kΩ
±2dB	8.258kΩ	26.375kΩ
±1dB	4.366kΩ	30.267kΩ

NJW1119A

(c) Treble Control
(c-1) Boost

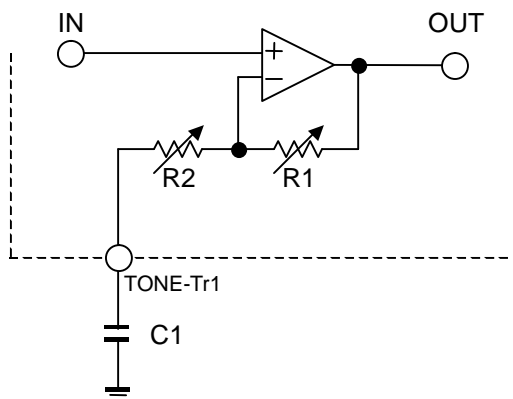

(c-2)Cut

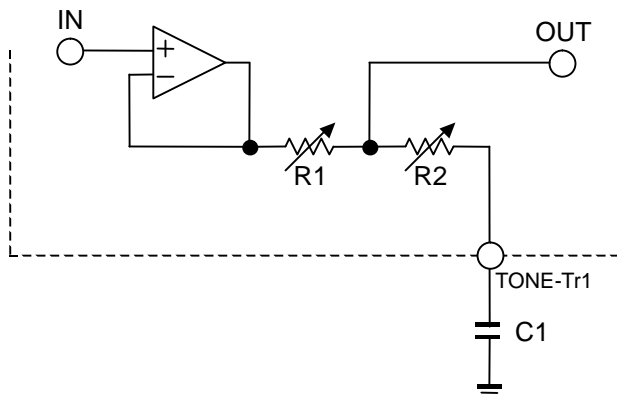

$$f_0 = \frac{1}{2\pi CR2}$$

$$G_V = \pm 20 \text{Log} \left[\frac{R1 + R2}{R2} \right]$$

Table.c-1 : Internal resistance in each Gain.

C1=2.2nF

Gain	R1	R2
±12dB	30.185KΩ	5.595kΩ
±11dB	28.51KΩ	7.27kΩ
±10dB	26.84KΩ	8.94kΩ
±9dB	25.09kΩ	10.69kΩ
±8dB	23.24kΩ	12.54kΩ
±7dB	21.24kΩ	14.54kΩ
±6dB	19.04kΩ	16.74kΩ
±5dB	16.64kΩ	19.14kΩ
±4dB	13.94kΩ	21.84kΩ
±3dB	11.04kΩ	24.74kΩ
±2dB	7.74kΩ	28.04kΩ
±1dB	4.14kΩ	31.64kΩ

TYPICAL CHARACTERISTICS

Operating Current (I_{DD}) vs. Power Supply Voltage
No signal

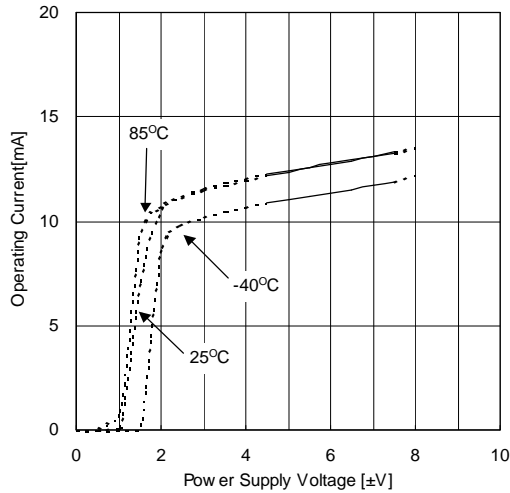

Operating Current (I_{EE}) vs. Power Supply Voltage
No signal

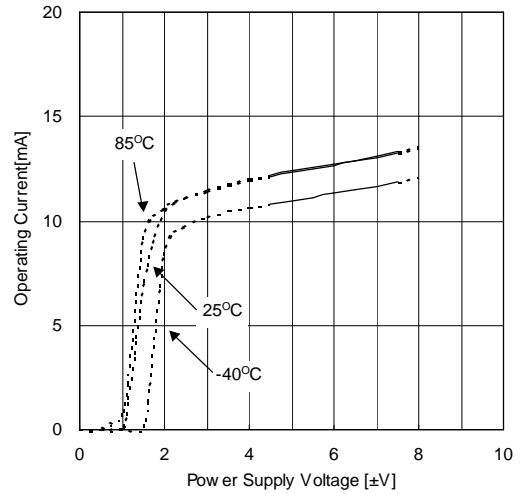

Operating Current vs. Ambient Temperature
 $V_{±} = ±7V$, No Signal

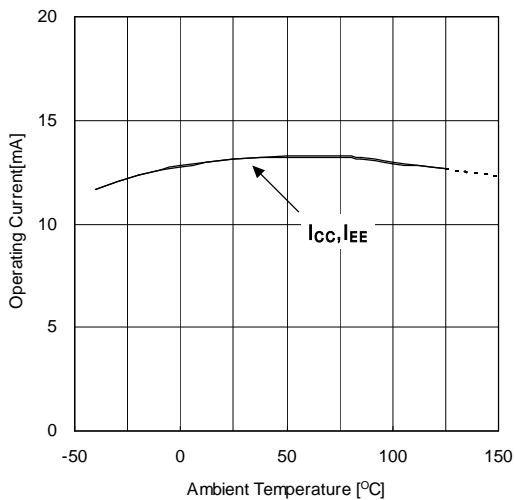

Maximum Output Voltage vs. Ambient Temperature
 $V_{±} = ±7V$, $f = 1kHz$, THD = 1%

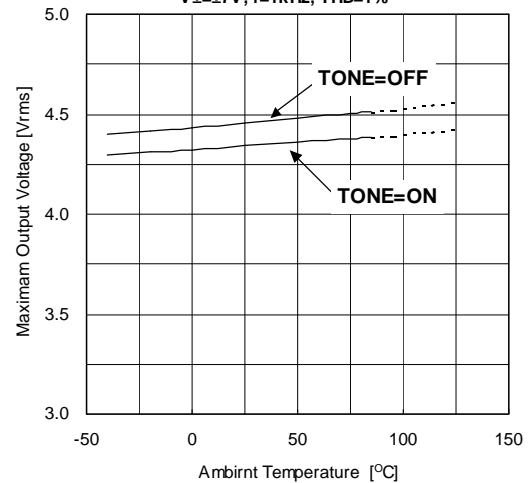

Maximum Output Voltage vs. Frequency
 $V_{±} = ±7V$, $f = 1kHz$, THD = 1%, TONE = OFF

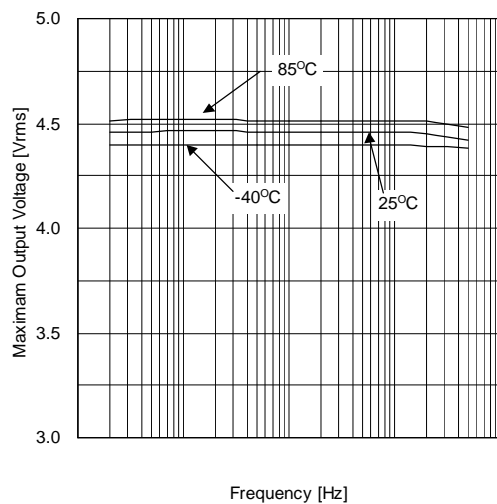

Maximum Output Voltage vs. Frequency
 $V_{±} = ±7V$, $f = 1kHz$, THD = 1%, TONE = ON

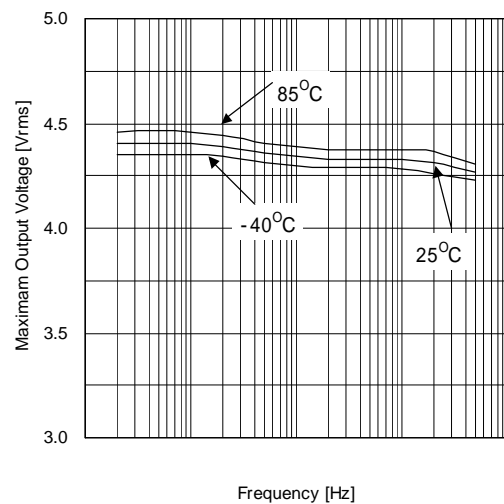

NJW1119A

TYPICAL CHARACTERISTICS

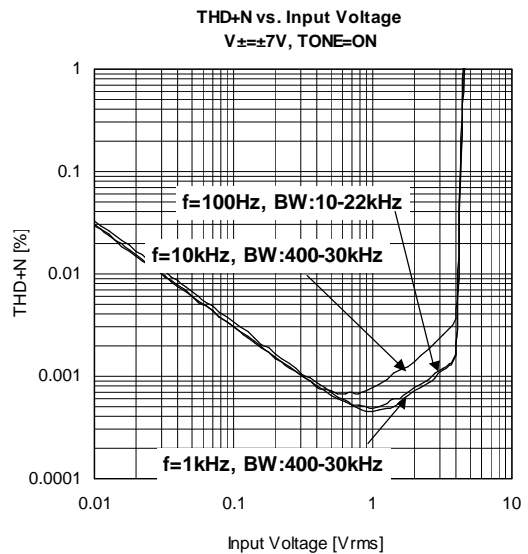
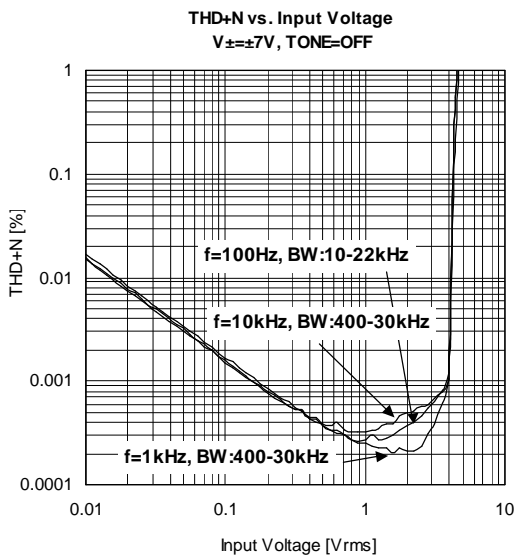
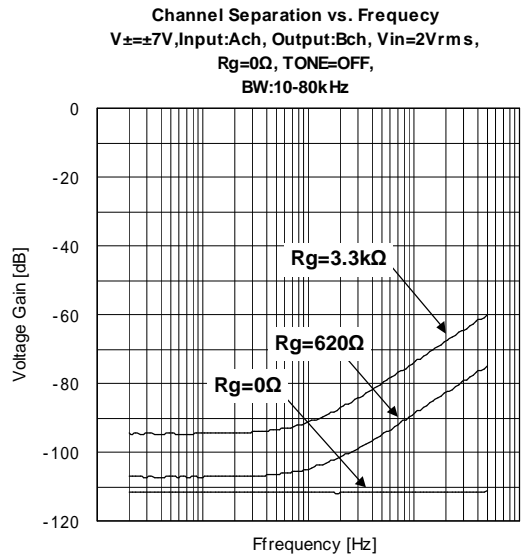
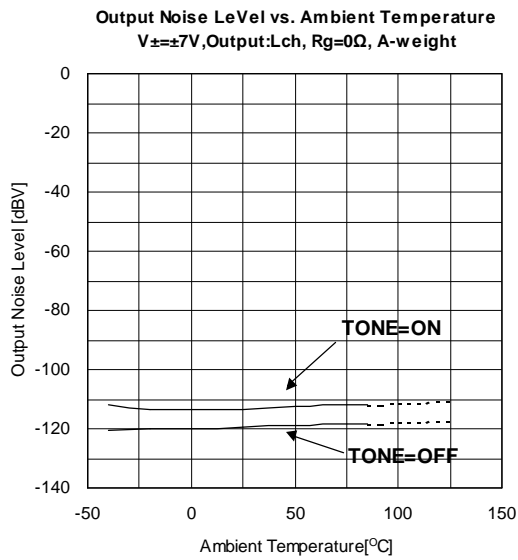
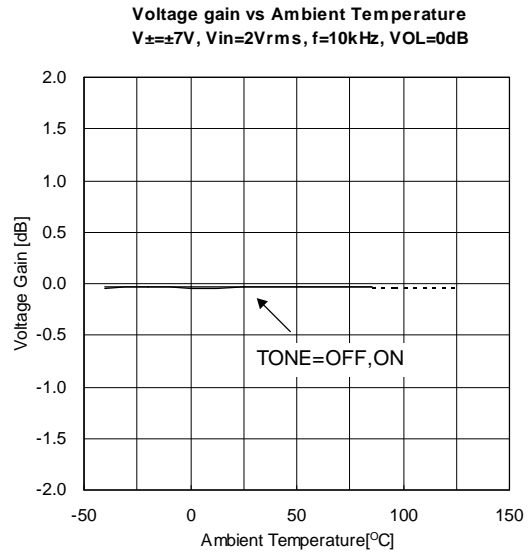
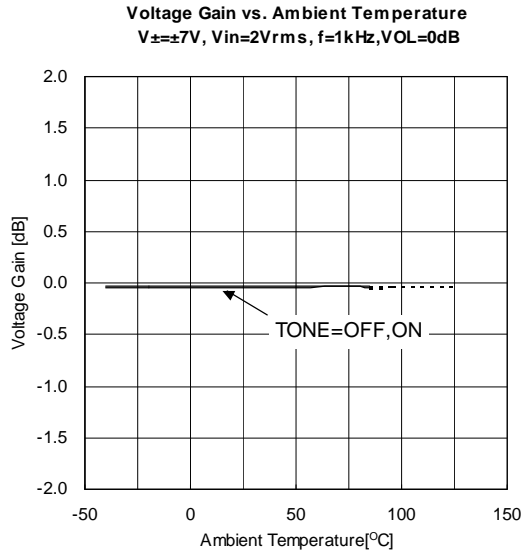

TYPICAL CHARACTERISTICS

THD+N vs. Ambient Temperature
 $V_{\pm}=\pm 7V$, $f=1kHz$, TONE=OFF, BW:400-30kHz

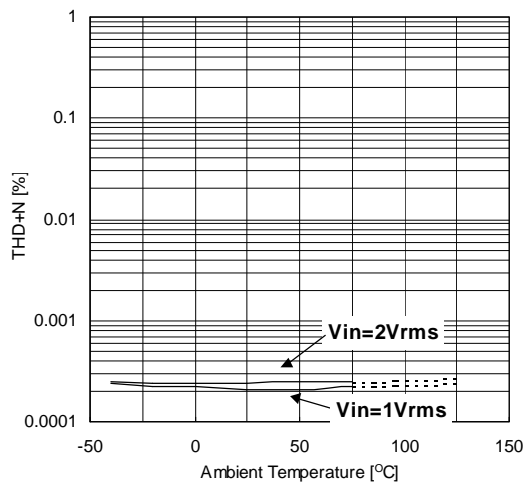

THD+N vs. Ambient Temperature
 $V_{\pm}=\pm 7V$, $f=1kHz$, TONE=ON, BW:400-30kHz

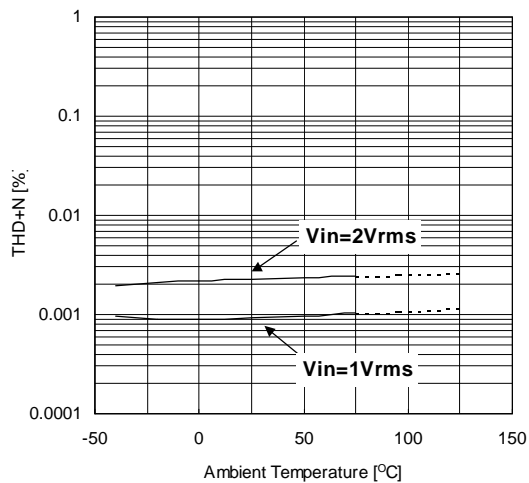

THD+N vs. Input Voltage
 $V_{\pm}=\pm 7V$, $f=1kHz$, TONE=OFF, BW:400-30kHz

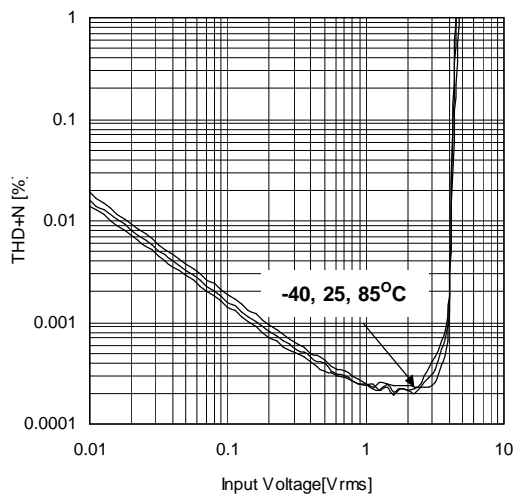

THD+N vs. Input Voltage
 $V_{\pm}=\pm 7V$, $f=1kHz$, TONE=ON, BW:400-30kHz

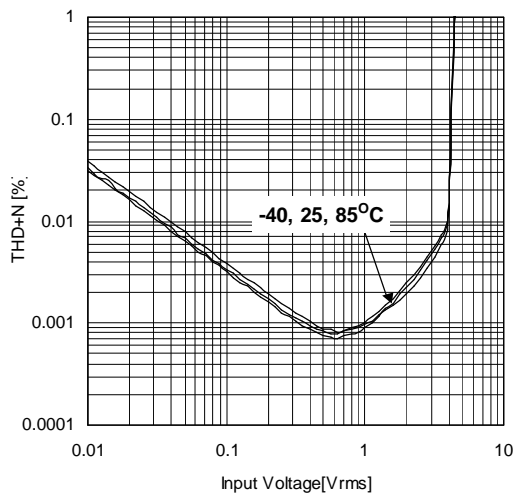

THD+N vs. Frequency
 $V_{\pm}=\pm 7V$, $V_{in}=2Vrms$, TONE=OFF, BW:10-80kHz

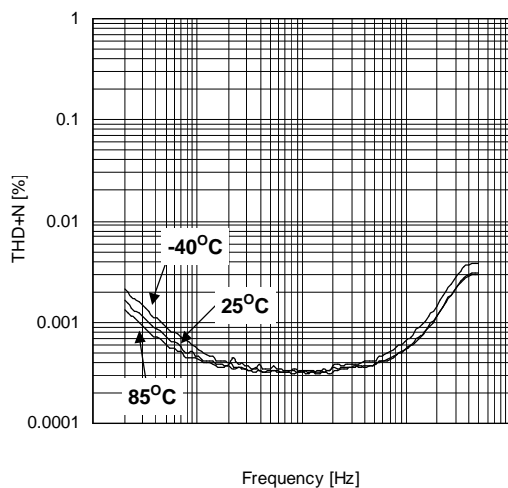

THD+N vs. Frequency
 $V_{\pm}=\pm 7V$, $V_{in}=2Vrms$, TONE=ON, BW:10-80kHz

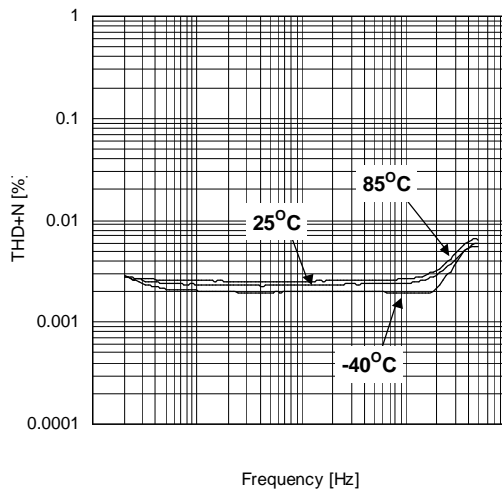

NJW1119A

TYPICAL CHARACTERISTICS

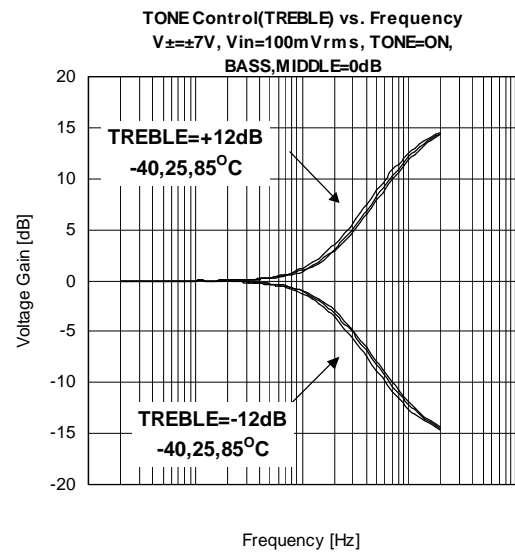
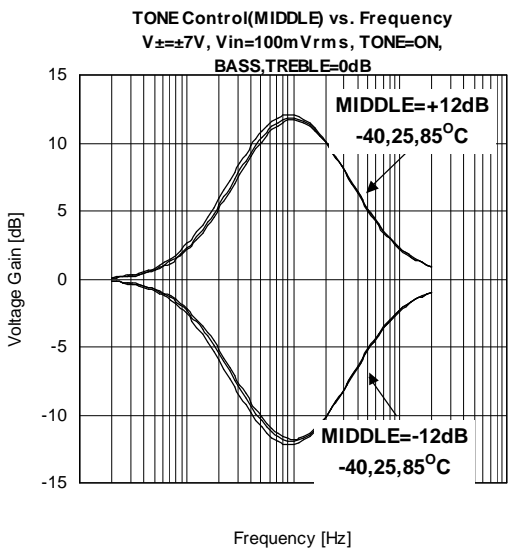
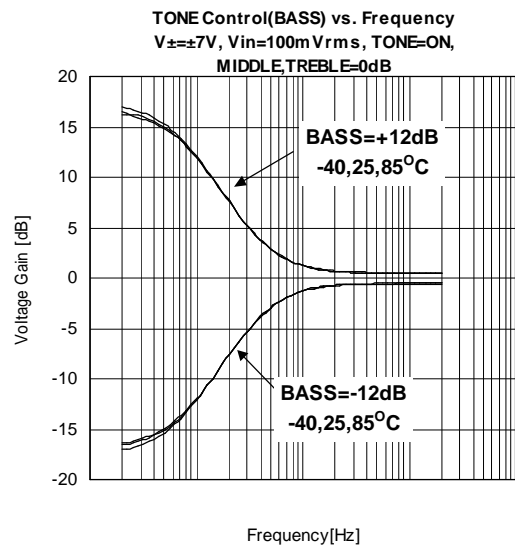
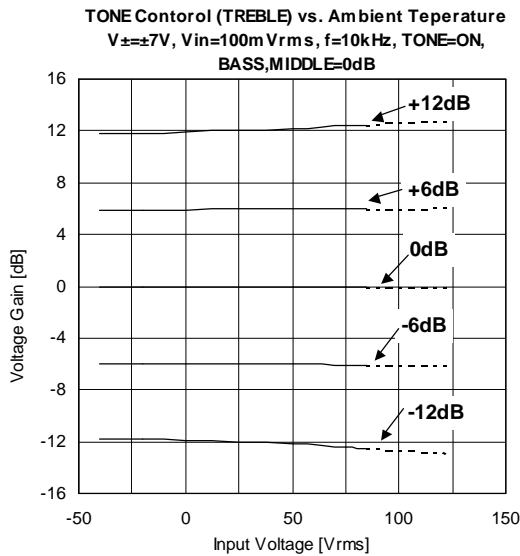
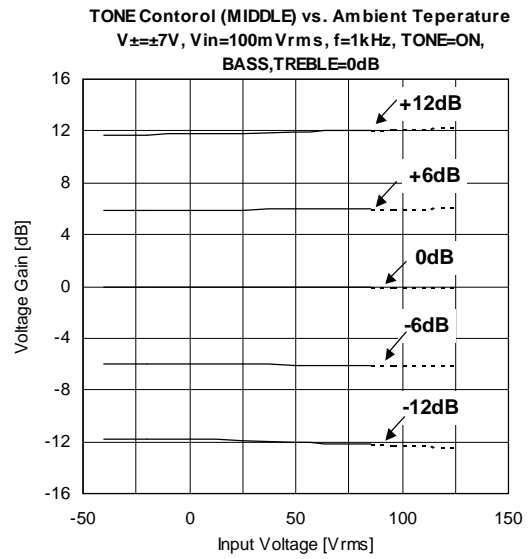
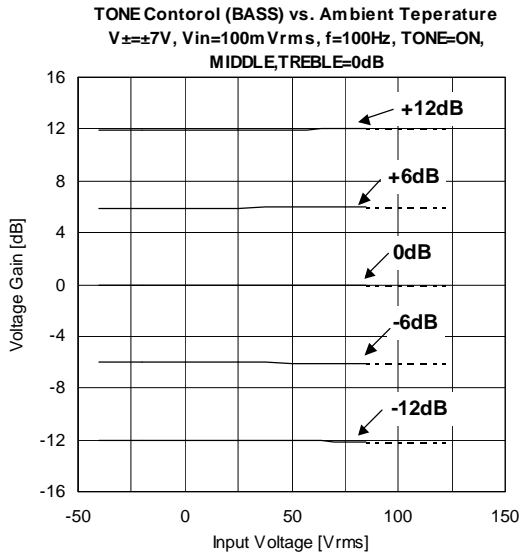

[CAUTION]
The specifications on this databook are only given for information , without any guarantee as regards either mistakes or omissions. The application circuits in this databook are described only to show representative usages of the product and not intended for the guarantee or permission of any right including the industrial rights.