



AUDIO PROCESSOR with Sound Enhancement and TruSurround

■ GENERAL DESCRIPTION

The NJW1139A is a sound processor with BBE sound enhancement and TruSurround virtualizer.

It includes all of functions processing audio signal for TV, such as tone control, balance, volume, mute, simulated stereo and AGC functions.

All of internal status and variables are controlled by I²C BUS interface.

■ PACKAGE OUTLINE

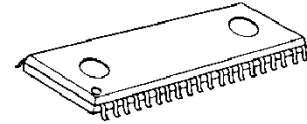

NJW1139AGK1

■ FEATURES

- Operating Voltage 8 to 13V
- I²C BUS Interface
- Bass Boost Function
Adjustable bass boost level 0 to +13dB
- AGC Circuit (It reduces volume difference among input sources)
Adjustable compression level by I²C BUS
- BBE Sound Enhancement System
- TruSurround / SRS 3D Stereo / Simulated Stereo
- Bi-CMOS Technology
- Package Outline SOP40-K1

■ BLOCK DIAGRAM

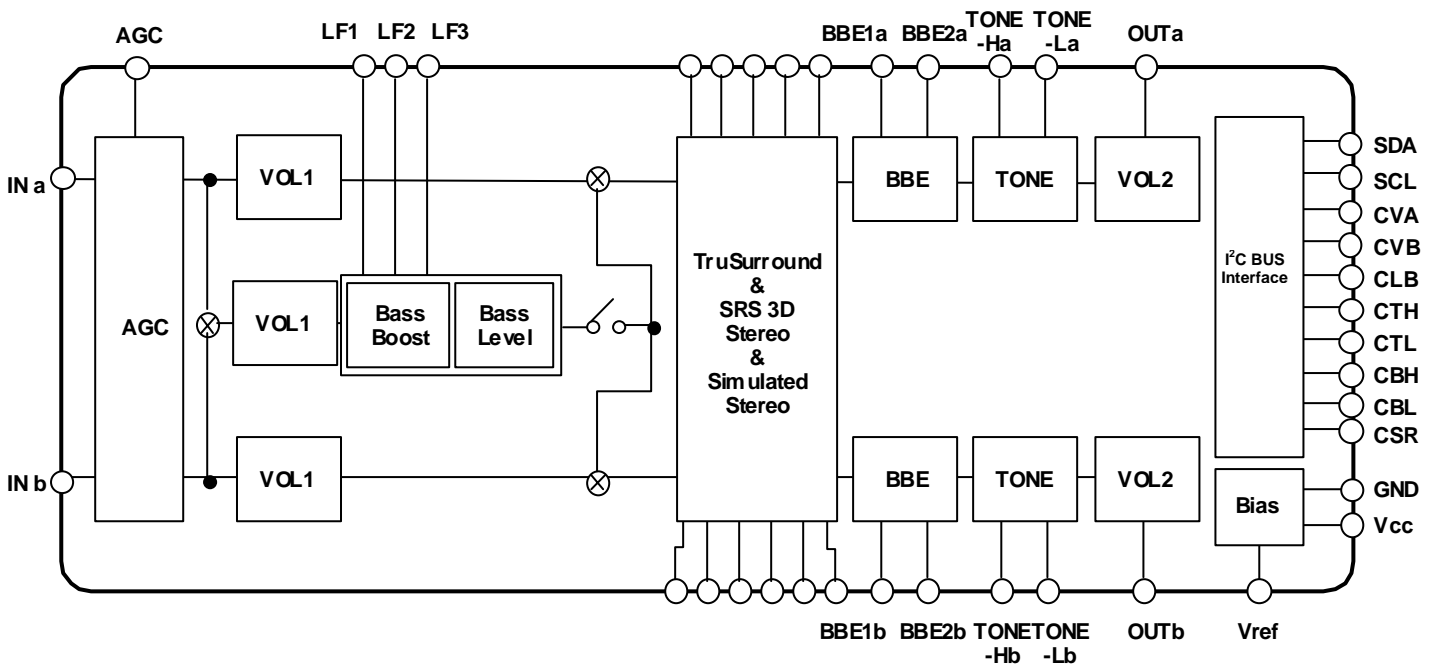

NJW1139A

www.DataSheet4U.com

■ PIN DISCRIPTION

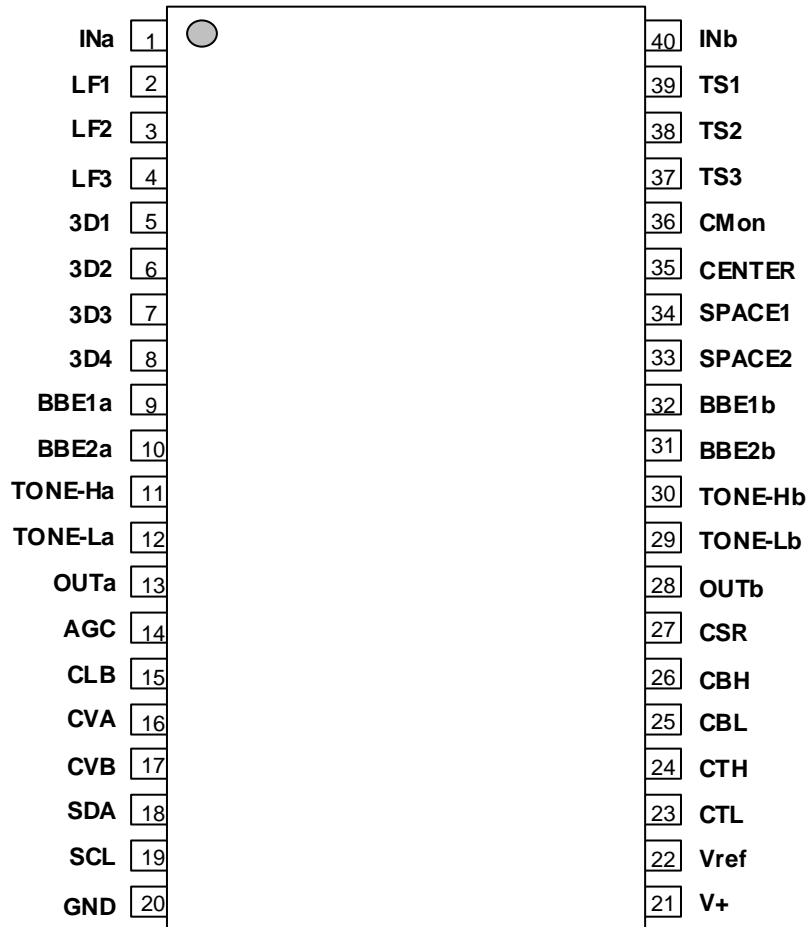

No.	Symbol	Function	No.	Symbol	Function
1	INa	Ach Input	21	V+	Power Supply
2	LF1	Bass Boost Filiter1	22	Vref	Reference Voltage
3	LF2	Bass Boost Filiter2	23	CTL	DAC Output for Tone Low Frequency
4	LF3	Bass Boost Filiter3	24	CTH	DAC Output for Tone High Frequency
5	3D1	SRS 3D Stereo Filiter1	25	CBL	DAC Output for BBE(Lo Contour)
6	3D2	SRS 3D Stereo Filiter2	26	CBH	DAC Output for BBE(Process)
7	3D3	SRS 3D Stereo Filiter3	27	CSR	DAC Output for Surround
8	3D4	SRS 3D Stereo Filiter4	28	OUTb	Bch Output
9	BBE1a	Ach BBE Filter1 (Process)	29	TONE-Lb	Bch Bass Filter
10	BBE2a	Ach BBE Filter2 (Lo Contour)	30	TONE-Hb	Bch Treble Filter
11	TONE-Ha	Ach Treble Filter	31	BBE2b	Bch BBE Filter2 (Process)
12	TONE-La	Ach Bass Filter	32	BBE1b	Bch BBE Filter1 (Lo Contour)
13	OUTa	Ach Output	33	SPACE2	SPACE VR2
14	AGC	AGC Filter	34	SPACE1	SPACE VR1
15	CLB	DAC Output for Bass Boost	35	CENTER	CENTER VR
16	CVA	DAC Output for Ach Volume & Balance	36	CMon	Simulated Stereo Filter
17	CVB	DAC Output for Bch Volume & Balance	37	TS3	TruSurround Filter3
18	SDA	SDA Data Input (I ² C BUS)	38	TS2	TruSurround Filter2
19	SCL	SCL Data Input (I ² C BUS)	39	TS1	TruSurround Filter1
20	GND	GND	40	INb	Bch Input

■ ABSOLUTE MAXIMUM RATING (Ta=25°C)

PARAMETER	SYMBOL	RATING	UNIT
Supply Voltage	V ⁺	15	V
Power Dissipation	P _D	700	mW
Operating Temperature Range	Topr	-20 to +75	°C
Storage Temperature Range	Tstg	-40 to +125	°C

■ ELECTRICAL CHARACTERISTICS

(Ta=25°C, V⁺=9V, R_g=600Ω, R_L=47kΩ, Vin=100mVrms/1kHz, unless otherwise specified)

PARAMETER	SYMBOL	TEST CONDITION	MIN.	TYP.	MAX.	UNIT
Operating Voltage	V ⁺		8.0	9.0	13.0	V
Supply Current	I _{CC}	No Signal	-	25	35	mA
Reference Voltage	V _{REF}	No Signal	4.0	4.5	5.0	V
Maximum Input Voltage	V _{IM}	VOL=-20dB, THD=1%	2.8	3.0	-	Vrms
Maximum Output Voltage	V _{OM}	VOL=0dB, THD=1%	-	2.5	-	Vrms
Channel Balance	G _{CB}	VOL=0dB	-1.5	0.0	1.5	dB
Balance Boost A	G _{BBA}	CHS="0", BAL="11111"	-2.0	0.0	2.0	dB
Balance Cut A	G _{BCA}	CHS="1", BAL="11111" Vin = 1Vrms	-	-	-70	dB
Balance Boost B	G _{BBB}	CHS="1", BAL="11111"	-2.0	0.0	2.0	dB
Balance Cut B	G _{BCB}	CHS="0", BAL="11111" Vin = 1Vrms	-	-	-70	dB
Bass Boost Gain	G _{TRB}	BBST = 1111, BBSW = 1	-	13.7	-	dB
Total Harmonic Distortion	THD	Vo=0.5Vrms BW=400Hz to 30kHz	-	-	0.5	%
Maximum Gain	G _{VMAX}	VOL=0dB	-2.0	0.0	2.0	dB
Minimum Gain	G _{VMIN}	VOL=MUTE	-	-	-70	dB
Channel Separation	G _{CS}	Vin=2Vrms	-	-	-70	dB
Output Noise 1	V _{NO1}	VOL=0dB BW=400Hz to 30kHz	-	-90 (31.6)	-85 (56.2)	dBV (μVrms)
Output Noise 2	V _{NO2}	VOL=MUTE BW=400Hz to 30kHz	-	-106 (5.0)	-96 (15.8)	dBV (μVrms)

◆ AGC

AGC Boost	G _{AGCBST}	Vin=50mVrms, f=1kHz	1.5	3.5	5.5	dB
AGC Flat1	G _{AGCFLT1}	Vin=300mVrms, f=1kHz	-2.5	0.0	2.5	dB
AGC Flat2	G _{AGCFLT2}	Vin=400mVrms, f=1kHz	-2.5	0.0	2.5	dB
AGC Flat3	G _{AGCFLT3}	Vin=500mVrms, f=1kHz	-2.5	0.0	2.5	dB
AGC Flat4	G _{AGCFLT4}	Vin=600mVrms, f=1kHz	-2.5	0.0	2.5	dB
AGC Cut	G _{AGCCUT}	Vin=2Vrms, f=1kHz	-14	-10	-6.0	dB

■ ELECTRICAL CHARACTERISTICS

(Ta=25°C, V+=9V, Rg=600Ω, RL=47kΩ, Vin=100mVrms/1kHz, unless otherwise specified)

PARAMETER	SYMBOL	TEST CONDITION	MIN.	TYP.	MAX.	UNIT
◆ TONE CONTROL						
High Frequency Boost	G _{HFBST}	TREB=+15dB, f=10kHz	12.5	15.0	17.5	dB
High Frequency Flat	G _{HFFLT}	TREB=0, f=10kHz	-2.0	0.0	2.0	dB
High Frequency Cut	G _{HFCUT}	TREB=-15dB, f=10kHz	-17.5	-15.0	-12.5	dB
Low Frequency Boost	G _{LFBST}	BASS=+15dB, f=100Hz	12.5	15.0	17.5	dB
Low Frequency Flat	G _{LFFLT}	BASS=0, f=100Hz	-2.0	0.0	2.0	dB
Low Frequency Cut	G _{LFcut}	BASS=-15dB, f=100Hz	-17.5	-15.0	-12.5	dB
Treble DC Offset1	HF _{DC1}	TREB=-15dB → 0dB	-0.3	0	0.3	V
Treble DC Offset2	HF _{DC2}	TREB=+15dB → 0dB	-0.3	0	0.3	V
Bass DC Offset1	LF _{DC1}	BASS=-15dB → 0dB	-0.3	0	0.3	V
Bass DC Offset2	LF _{DC2}	BASS=+15dB → 0dB	-0.3	0	0.3	V
◆ SUB-TONE CONTROL						
High Frequency Boost	G _{SHFBST}	SUB-TREB=+3dB, f=10kHz	2.0	3.0	4.0	dB
High Frequency Cut	G _{SHFCUT}	SUB-TREB=-3dB, f=10kHz	-4.0	-3.0	-2.0	dB
Low Frequency Boost	G _{SLEBST}	SUB-BASS=+3dB, f=100Hz	2.0	3.0	4.0	dB
Low Frequency Cut	G _{SLEcut}	SUB-BASS=-3dB, f=100Hz	-4.0	-3.0	-2.0	dB
◆ TruSurround (TRU Mode)						
TruSurround Gain1	G _{TS1}	Ain→Aout, f=1kHz	0.3	2.3	4.3	dB
TruSurround Gain2	G _{TS2}	Ain→Bout, f=1kHz	-13.4	-11.4	-9.4	dB
◆ SRS 3D Stereo (SRS 3D Stereo Mode)						
Feed Through Gain	G _{THROUGH}	Ain→Aout, f=1kHz SPACE1 VR Min CENTER VR Min	-20.2	-18.2	-16.2	dB
L+R Gain	G _{L+R}	Ain→Bout, f=1kHz SPACE1 VR Min CENTER VR Max	-15.0	-13.0	-11.0	dB
L-R Gain	G _{L-R}	Ain→Aout, f=125Hz SPACE1 VR Max CENTER VR Min	-2.0	0.0	2.0	dB
Surround DC Offset1	SR _{DC1}	Bypass → TSV	-0.3	0	0.3	V
◆ Simulated Stereo(Simulated Stereo Mode)						
Simulated Surround Gain1	G _{SIM1}	Ain+Bin→Aout, f=1kHz	1.0	3.0	5.0	dB
Simulated Surround Gain2	G _{SIM2}	Ain+Bin→Bout, f=1kHz	1.0	3.0	5.0	dB
Surround DC Offset2	SR _{DC2}	Bypass → Simulated Stereo	-0.3	0	0.3	V
◆ BBE						
BBE Low Frequency Boost Level	G _{BBELOW}	BBE-LOW = +15dB	-	15.0	-	dB
BBE High Frequency Boost Level	G _{BBEHIGH}	BBE-HIGH = +15dB	-	15.0	-	dB
BBE DC Offset	BBE _{DC}	Bypass OFF → ON	-0.3	0	0.3	V

■ I²C BUS BLOCK CHARACTERISTICS (SDA,SCL)

PARAMETER	SYMBOL	MIN.	TYP.	MAX.	UNIT
High Level Input Voltage	V _{IH}	3.0	-	5.0	V
Low Level Input Voltage	V _{IL}	0	-	1.5	V
High Level Input Current	I _{IH}	-	-	10	μA
Low Level Input Current	I _{IL}	-	-	10	μA
Low Level Output Voltage (3mA at SDA pin)	V _{OL}	0	-	0.4	V
Maximum Output Current	I _{OL}	-3.0	-	-	mA
Maximum Clock Frequency	f _{SCL}	-	-	100	kHz
Data Change Minimum Waiting Time	t _{BUF}	4.7	-	-	μs
Data Transfer Start Minimum Waiting Time	t _{HD:STA}	4.0	-	-	μs
Low Level Clock Pulse Width	t _{LOW}	4.7	-	-	μs
High Level Clock Pulse Width	t _{HIGH}	4.0	-	-	μs
Minimum Start Preparation Waiting Time	t _{SU:STA}	4.7	-	-	μs
Minimum Data Hold Time	t _{HD:DAT}	0	-	3.45	μs
Minimum Data Preparation Time	t _{SU:DAT}	250	-	-	ns
Rise Time	t _R	-	-	1.0	μs
Fall Time	t _F	-	-	300	ns
Minimum Stop Preparation Waiting Time	t _{SU:STO}	4.0	-	-	μs

I²C BUS Load Condition: Pull up resistance 4kΩ (Connected to +5V)
Load capacitance 200pF (Connected to GND)

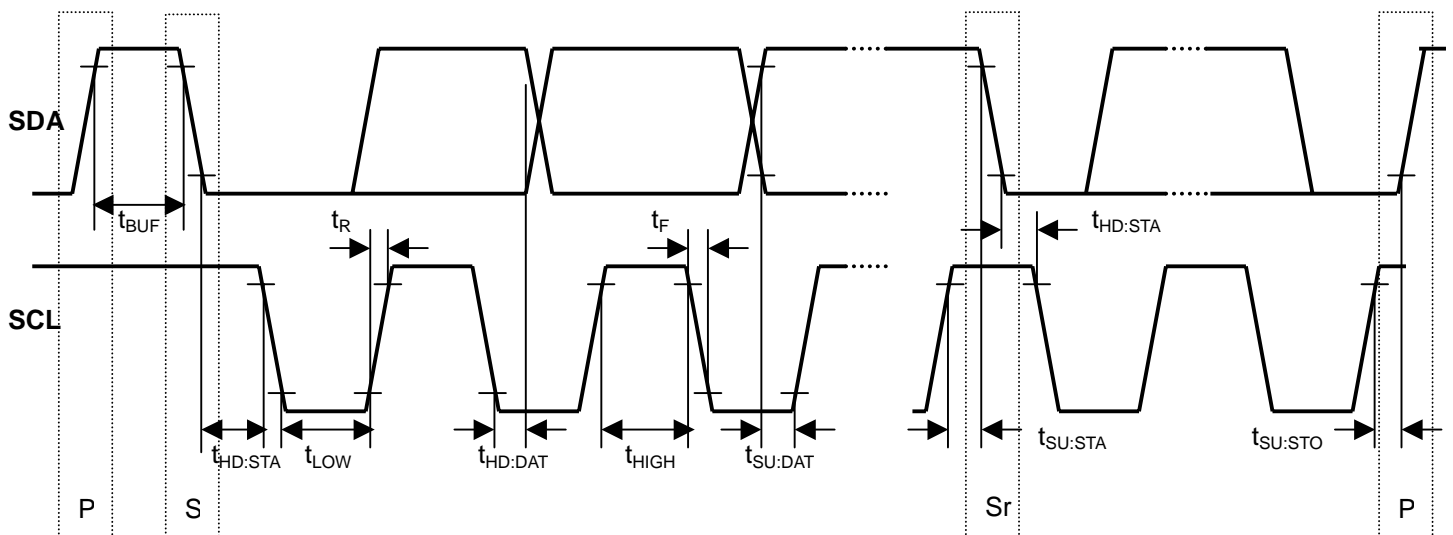

NJW1139A

www.DataSheet4U.com

APPLICATION CIRCUIT

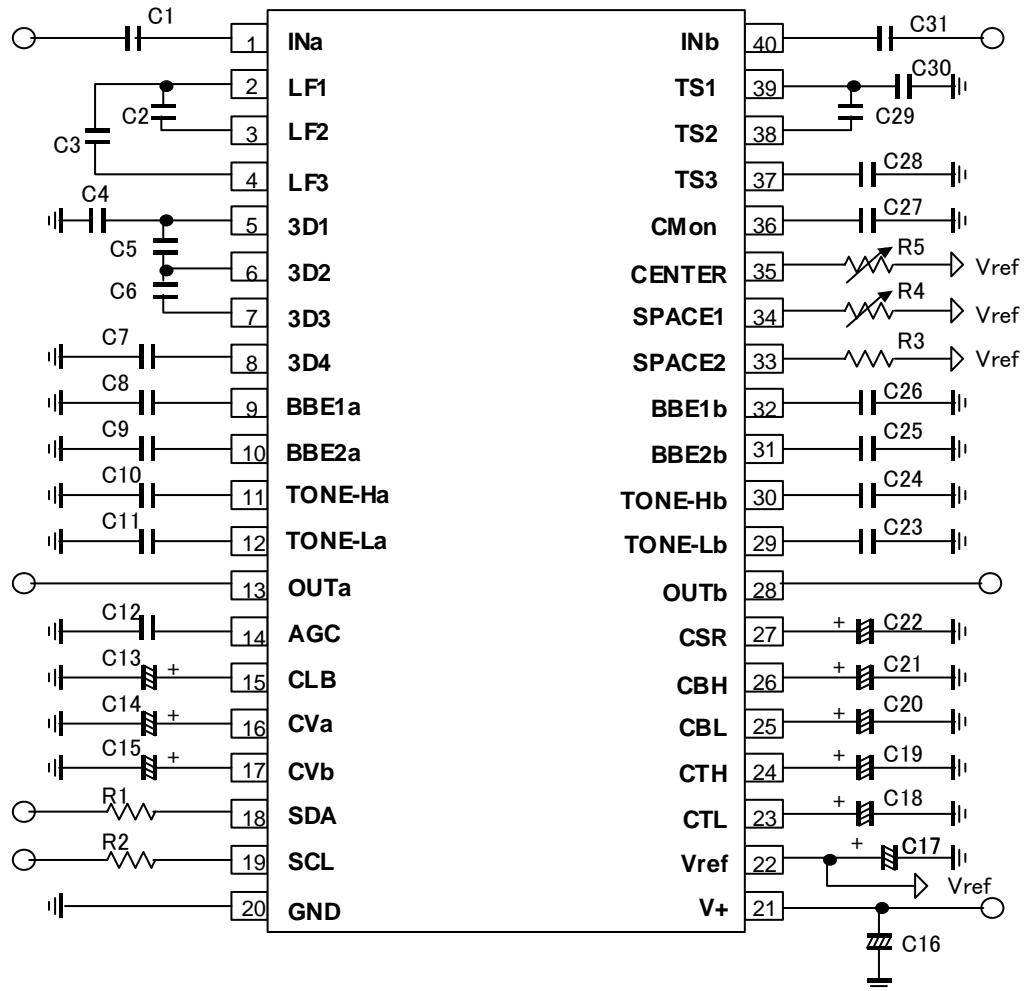

Parts No.	Value	Parts No.	Value
C1, C2, C3, C31	0.1 μ F	C12	330nF
C4, C30	10nF	C13, C14, C15, C18, C19, C20, C21, C22	1 μ F
C5, C7	0.22 μ F	R1, R2	3.9k Ω
C6, C28, C29	4.7nF	C16	10 μ F
C8, C26	3.3nF	C17	100 μ F
C9, C25	33nF	R3	9.1k Ω
C10, C24	2.2nF	R4, R5	20k Ω
C11, C23	100nF	C27	6.8nF

■ OPERATING INSTRUCTION

<Bass Boost Function>

Adjusting "fc (Center Frequency)" and "Q (Quality Factor)" enable to optimize the bass effect.

◆ Bass Boost Block

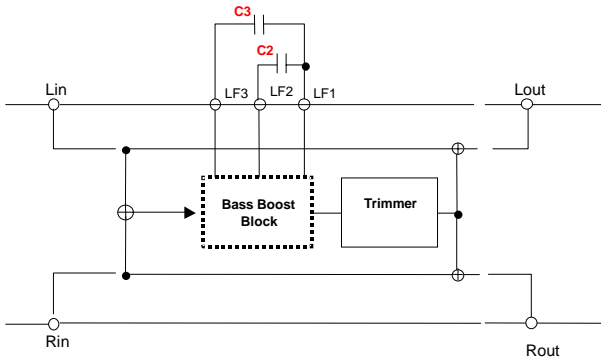

◆ Bass Boost Block Detail

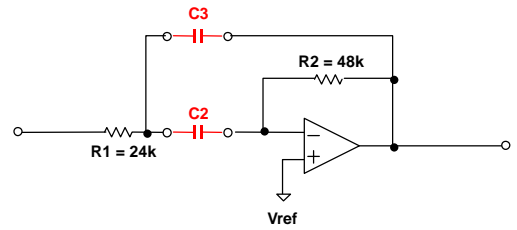

◆ Transfer Function of Bass Boost Block

$$H(S) = \frac{-A\omega S}{S^2 + \alpha\omega S + \omega^2} = \frac{-\frac{1}{R1 \cdot C3}}{S^2 + \frac{C3 + C2}{C3 \cdot C2 \cdot R2} S + \frac{1}{C3 \cdot C2 \cdot R1 \cdot R2}}$$

◆ fc (Center Frequency)

$$fc = \frac{1}{2\pi(R1\sqrt{2}C3 \cdot C2)}$$

◆ Q (Quality Factor)

$$Q = \frac{1}{\alpha} = \frac{\sqrt{2 \cdot C3 \cdot C2}}{C3 + C2}$$

< Surround Function >

◆ Surround Mode

- TRU (TruSurround) Mode : Virtual Surround Mode (Fixed effect)
- TSV (TruSurround) Mode : Virtual Surround Mode (Variable effects by SPACE1, 2 & CENTER VR)
- Simulated Stereo Mode : Simulated Stereo Mode
- SRS 3D Stereo Mode : 3D Stereo Mode (Variable effects by SPACE1 & CENTER VR)

◆ Surround Effect Settings

Surround effects on TSV Mode and SRS 3D Stereo Mode are adjustable by SPACE & CENTER VR.

<SRS 3D Stereo Mode>

- 1, CENTER : Adjust the center orientation
 - 2, SPACE1: Adjust the surround effect
- SPACE2 VR value is not related to the SRS 3D Stereo Mode.

<TSV Mode>

- "Standard setting" (SRS Recommendation)
- 1, CENTER : Adjust the center orientation
 - 2, SPACE1 : Adjust the surround effect



NJW1139A

www.DataSheet4U.com

■TERMINAL DESCRIPTION

No.	SYMBOL	FUNCTION	EQUIVALENT CIRCUIT	VOLTAGE
1 40	INa, INb	Input Pin		V+/2
2	LF1	Bass Boost Setting		V+/2
3	LF2	Bass Boost Setting		1.4V
4	LF3	Bass Boost Setting		-

■TERMINAL DESCRIPTION

No.	SYMBOL	FUNCTION	EQUIVALENT CIRCUIT	VOLTAGE
5 6 7 8 37 38 39	3D1 3D2 3D3 3D4 TS3 TS2 TS1	Surround Filter		-
9 10 31 32	BBE1a BBE2a BBE2b BBE1b	Ach BBE Filter (Process) Ach BBE Filter (Lo Countour) Bch BBE Filter (Lo Countour) Bch BBE Filter (Process)		V+/2
11 30	TONE-Ha TONE-Hb	A/Bch Treble Filter		V+/2
12 29	TONE-La TONE-Lb	A/Bch Bass Filter		V+/2

NJW1139A

www.DataSheet4U.com

■ TERMINAL DESCRIPTION

No.	SYMBOL	FUNCTION	EQUIVALENT CIRCUIT	VOLTAGE
13 28	OUTa OUTb	Output Pin		$V+/2$
14	AGC	AGC		1.4V
15	CLB	DAC Output for Bass Boost		$V+/2$
16 17	CVa CVb	DAC Output for A/Bch Volume & Balance		$V+/2$

■TERMINAL DESCRIPTION

No.	SYMBOL	FUNCTION	EQUIVALENT CIRCUIT	VOLTAGE
18 19	SDA SCL	SDA Data Input (I ² C BUS) SCL Data Input (I ² C BUS)		-
20	GND	GND Pin		-
21	VCC	Voltage Supply Pin		-
22	VREF	Reference Voltage		V+/2
23 24	CTL CTH	DAC Output for Tone Control(Treble and Bass)		V+/2

■ TERMINAL DESCRIPTION

No.	SYMBOL	FUNCTION	EQUIVALENT CIRCUIT	VOLTAGE
25 26	CBL CBH	DAC Output for BBE (Process and Lo Contour)		V+/2
27	CSR	DAC Output for Surround		0V
33 34 35	SPACE2 SPACE1 CENTER	Surround Volume		-
36	CMon	Surround Filter		-

■ DEFINITION OF I²C REGISTER

◆ I²C BUS FORMAT

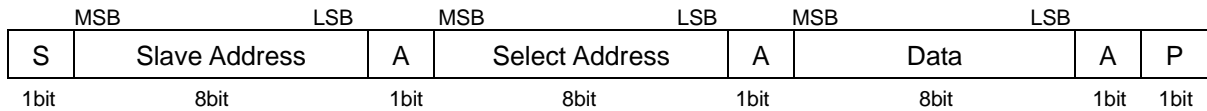

S: Starting Term

A: Acknowledge Bit

P: Ending Term

◆ SLAVE ADDRESS

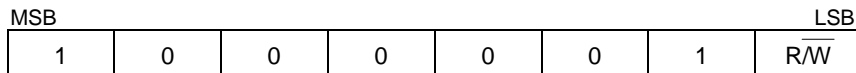

R/W = 0 : Receive Only

◆ CONTROL REGISTER TABLE

The select address sets each function (Volume, Balance, Bass Boost Select, AGC, Surround, Tone Control).

The auto-increment function cycles the select address as follows.

00H→01H→02H→03H→04H→05H→06H→00H

Select Address	BIT							
	D7	D6	D5	D4	D3	D2	D1	D0
00H	VOL							
01H	CHS	BAL					BBE	AGC
02H	BBST				BBSW	Don't Care		
03H	BCB	BASS				BCSB	SUB-BASS	
04H	BCT	TREB				BCST	SUB-TREB	
05H	BBE-LOW(Lo Contour)				BBE-HIGH(Process)			
06H	OUT	SUR			AGCL		Don't Care	

◆ CONTROL REGISTER DEFAULT VALUE

Control register default value is all "0".

Select Address	BIT							
	D7	D6	D5	D4	D3	D2	D1	D0
00H	0	0	0	0	0	0	0	0
01H	0	0	0	0	0	0	0	0
02H	0	0	0	0	0	0	0	0
03H	0	0	0	0	0	0	0	0
04H	0	0	0	0	0	0	0	0
05H	0	0	0	0	0	0	0	0
06H	0	0	0	0	0	0	0	0

■ INSTRUCTION CODE

a) MASTER VOLUME SETTING

Select Address	BIT							
	D7	D6	D5	D4	D3	D2	D1	D0
00H	VOL							

●VOL : Master Volume Setting

Attenuation level : 0 to -80dB(0.33dB/step), MUTE

The volume is consisted of VOL1 and VOL2 and the level is divided into half to each VOL1 and VOL2.

b) BALANCE AND BASS BOOST FUNCTION SETTING

Select Address	BIT							
	D7	D6	D5	D4	D3	D2	D1	D0
01H	CHS	BAL					BBE	AGC

●CHS : Channel select for balance control

“0” : Ach “Bch is attenuated”

“1” : Bch “Ach is attenuated”

●BAL : Balance control for both Ach and Bch

Balance Level : 0 to -30dB (1dB/Step) , MUTE

●BBE : BBE ON/OFF Switch

“0” = BBE OFF

“1” = BBE ON

●AGC: AGC ON/OFF Switch

“0” = AGC OFF

“1” = AGC ON

c) BASS BOOST LEVEL SETTING

Select Address	BIT							
	D7	D6	D5	D4	D3	D2	D1	D0
02H	BBST				BBSW	Don't Care		

●BBST : Bass Boost Level Setting

Bass Boost Level : 0 to +13dB

●BBSW : Bass Boost ON/OFF Switch

“0” : OFF

“1” : ON

d) TONE CONTROL BASS & SUB-BASS SETTING

Select Address	BIT							
	D7	D6	D5	D4	D3	D2	D1	D0
03H	BCB	BASS				BCSB	SUB-BASS	

●BCB : Boost cut select for Bass control

“0” : Cut

“1” : Boost

●BASS : BASS Level Setting

Cut Level : -15 to 0dB(1dB/Step)

Boost Level : 0 to +15dB(1dB/Step)

●SBCB : Boost cut select for SUB-Bass control

“0” : Cut

“1” : Boost

●SUB-BASS : SUB-BASS Level Setting

Cut Level : -3 to 0dB(1dB/Step)

Boost Level : 0 to +3dB(1dB/Step)

e) TONE CONTROL TREBLE SETTING

Select Address	BIT							
	D7	D6	D5	D4	D3	D2	D1	D0
04H	BCT	TREB				BCST	SUB-TREB	

●BCT : Boost cut select for Treble control

"0" : Cut
 "1" : Boost

●TREB : Treble Level Setting

Cut Level : -15 to 0dB(1dB/Step)
 Boost Level : 0 to +15dB(1dB/Step)

●SBCT : Boost cut select for SUB-TREB control

"0" : Cut
 "1" : Boost

●SUB-TREB : SUB-TREB Level Setting

Cut Level : -3 to 0dB(1dB/Step)
 Boost Level : 0 to +3dB(1dB/Step)

f) BBE SETTING

Select Address	BIT							
	D7	D6	D5	D4	D3	D2	D1	D0
05H	BBE-LOW (Lo Contour)				BBE-HIGH (Process)			

- BBE-LOW(Lo Contour) : 0dB to 15dB(1dB/step)
- BBE-HIGH(Process) : 0dB to 15dB (1dB/step)

When all bits are "0"(00H), BBE becomes off.

g) SURROUND, AGC LEVEL SETTING

Select Address	BIT							
	D7	D6	D5	D4	D3	D2	D1	D0
06H	OUT	SUR			AGCL		Don't Care	

●OUT : Output setting

Output Setting	D7
Output ON	1
Output OFF	0

●SUR : Surround setting

Surround Setting	D6	D5	D4	Note
Bypass	0	-	0	Bypass Mode
Simulated Stereo	0	0	1	Simulated Stereo Mode
TRU (Fixed Effect)	1	0	1	Lt/Rt Input Mode
SRS 3D Stereo	0	1	1	SRS 3D Stereo Mode (Normal Stereo Source) Variable Effects by SPACE1 VR & CENTER VR
TSV (Variable Effect)	1	1	1	TRU Mode + Variable Effects by SPACE1,2 VR & CENTER VR

●AGCL : AGC Level setting

AGC Level Setting	D3	D2
300mVrms	0	0
400mVrms	0	1
500mVrms	1	0
600mVrms	1	1

NJW1139A

www.DataSheet4U.com

■Master Volume (Select Address: 00H)

		VOL							
Gain (dB)	HEX	D7	D6	D5	D4	D3	D2	D1	D0
0	FF	1	1	1	1	1	1	1	1
-1	FC	1	1	1	1	1	1	0	0
-2	F9	1	1	1	1	1	0	0	1
-3	F6	1	1	1	1	0	1	1	0
-4	F3	1	1	1	1	0	0	1	1
-5	F0	1	1	1	1	0	0	0	0
-6	ED	1	1	1	0	1	1	0	1
-7	EA	1	1	1	0	1	0	1	0
-8	E7	1	1	1	0	0	1	1	1
-9	E4	1	1	1	0	0	1	0	0
-10	E1	1	1	1	0	0	0	0	1
-11	DE	1	1	0	1	1	1	1	0
-12	DB	1	1	0	1	1	0	1	1
-13	D8	1	1	0	1	1	0	0	0
-14	D5	1	1	0	1	0	1	0	1
-15	D2	1	1	0	1	0	0	1	0
-16	CF	1	1	0	0	1	1	1	1
-17	CC	1	1	0	0	1	1	0	0
-18	C9	1	1	0	0	1	0	0	1
-19	C6	1	1	0	0	0	1	1	0
-20	C3	1	1	0	0	0	0	1	1
-21	C0	1	1	0	0	0	0	0	0
-22	BD	1	0	1	1	1	1	0	1
-23	BA	1	0	1	1	1	0	1	0
-24	B7	1	0	1	1	0	1	1	1
-25	B4	1	0	1	1	0	1	0	0
-26	B1	1	0	1	1	0	0	0	1
-27	AE	1	0	1	0	1	1	1	0
-28	AB	1	0	1	0	1	0	1	1
-29	A8	1	0	1	0	1	0	0	0
-30	A5	1	0	1	0	0	1	0	1
-31	A2	1	0	1	0	0	0	1	0
-32	9F	1	0	0	1	1	1	1	1
-33	9C	1	0	0	1	1	1	0	0
-34	99	1	0	0	1	1	0	0	1
-35	96	1	0	0	1	0	1	1	0
-36	93	1	0	0	1	0	0	1	1
-37	90	1	0	0	1	0	0	0	0
-38	8D	1	0	0	0	1	1	0	1
-39	8A	1	0	0	0	1	0	1	0
-40	87	1	0	0	0	0	1	1	1
-41	84	1	0	0	0	0	1	0	0
-42	81	1	0	0	0	0	0	0	1

		VOL							
		D7	D6	D5	D4	D3	D2	D1	D0
Gain (dB)	HEX								
-43	7E	0	1	1	1	1	1	1	0
-44	7B	0	1	1	1	1	0	1	1
-45	78	0	1	1	1	1	0	0	0
-46	75	0	1	1	1	0	1	0	1
-47	72	0	1	1	1	0	0	1	0
-48	6F	0	1	1	0	1	1	1	1
-49	6C	0	1	1	0	1	1	0	0
-50	69	0	1	1	0	1	0	0	1
-51	66	0	1	1	0	0	1	1	0
-52	63	0	1	1	0	0	0	1	1
-53	60	0	1	1	0	0	0	0	0
-54	5D	0	1	0	1	1	1	0	1
-55	5A	0	1	0	1	1	0	1	0
-56	57	0	1	0	1	0	1	1	1
-57	54	0	1	0	1	0	1	0	0
-58	51	0	1	0	1	0	0	0	1
-59	4E	0	1	0	0	1	1	1	0
-60	4B	0	1	0	0	1	0	1	1
-61	48	0	1	0	0	1	0	0	0
-62	45	0	1	0	0	0	1	0	1
-63	42	0	1	0	0	0	0	1	0
-64	3F	0	0	1	1	1	1	1	1
-65	3C	0	0	1	1	1	1	0	0
-66	39	0	0	1	1	1	0	0	1
-67	36	0	0	1	1	0	1	1	0
-68	33	0	0	1	1	0	0	1	1
-69	30	0	0	1	1	0	0	0	0
-70	2D	0	0	1	0	1	1	0	1
-71	2A	0	0	1	0	1	0	1	0
-72	27	0	0	1	0	0	1	1	1
-73	24	0	0	1	0	0	1	0	0
-74	21	0	0	1	0	0	0	0	1
-75	1E	0	0	0	1	1	1	1	0
-76	1B	0	0	0	1	1	0	1	1
-77	18	0	0	0	1	1	0	0	0
-78	15	0	0	0	1	0	1	0	1
-79	12	0	0	0	1	0	0	1	0
-80	0F	0	0	0	0	1	1	1	1
Mute	00	0	0	0	0	0	0	0	0

■Balance Setting (Select Address: 01H)

Channel Setting (CHS)	D7
Attenuated Bch Gain	0
Attenuated Ach Gain	1

Gain(dB)	BAL				
	D6	D5	D4	D3	D2
0	0	0	0	0	0
-1	0	0	0	0	1
-2	0	0	0	1	0
-3	0	0	0	1	1
-4	0	0	1	0	0
-5	0	0	1	0	1
-6	0	0	1	1	0
-7	0	0	1	1	1
-8	0	1	0	0	0
-9	0	1	0	0	1
-10	0	1	0	1	0
-11	0	1	0	1	1
-12	0	1	1	0	0
-13	0	1	1	0	1
-14	0	1	1	1	0
-15	0	1	1	1	1
-16	1	0	0	0	0
-17	1	0	0	0	1
-18	1	0	0	1	0
-19	1	0	0	1	1
-20	1	0	1	0	0
-21	1	0	1	0	1
-22	1	0	1	1	0
-23	1	0	1	1	1
-24	1	1	0	0	0
-25	1	1	0	0	1
-26	1	1	0	1	0
-27	1	1	0	1	1
-28	1	1	1	0	0
-29	1	1	1	0	1
-30	1	1	1	1	0
MUTE	1	1	1	1	1

■ Bass Boost Setting (Select Address: 02H)

Step	BBST				Boost Gain (dB) ^(*)
	D7	D6	D5	D4	
15	1	1	1	1	13.7
14	1	1	1	0	13.2
13	1	1	0	1	12.6
12	1	1	0	0	12.0
11	1	0	1	1	11.9
10	1	0	1	0	10.2
9	1	0	0	1	9.3
8	1	0	0	0	8.2
7	0	1	1	1	7.2
6	0	1	1	0	6.2
5	0	1	0	1	5.3
4	0	1	0	0	4.5
3	0	0	1	1	3.7
2	0	0	1	0	3.0
1	0	0	0	1	2.4
0	0	0	0	0	0

^(*) Reference Value

■Tone Control Bass Setting (Select Address: 03H)

Bass Cut or Boost	BCB
	D7
Cut	0
Boost	1

		BASS			
		D6	D5	D4	D3
Cut Gain(dB)	Boost Gain(dB)				
-15	15	1	1	1	1
-14	14	1	1	1	0
-13	13	1	1	0	1
-12	12	1	1	0	0
-11	11	1	0	1	1
-10	10	1	0	1	0
-9	9	1	0	0	1
-8	8	1	0	0	0
-7	7	0	1	1	1
-6	6	0	1	1	0
-5	5	0	1	0	1
-4	4	0	1	0	0
-3	3	0	0	1	1
-2	2	0	0	1	0
-1	1	0	0	0	1
0	0	0	0	0	0

■Tone Control Sub Bass (Select Address: 03H)

Sub-Bass Cut or Boost	BCSB
	D2
Cut	0
Boost	1

		SUB-BASS	
		D1	D0
Cut Gain(dB)	Boost Gain(dB)		
-3	3	1	1
-2	2	1	0
-1	1	0	1
0	0	0	0

■Tone Control Treble Setting (Select Address: 04H)

Treble Cut or Boost	BCT
	D7
Cut	0
Boost	1

		TREB			
		D6	D5	D4	D3
Cut Gain(dB)	Boost Gain(dB)				
-15	15	1	1	1	1
-14	14	1	1	1	0
-13	13	1	1	0	1
-12	12	1	1	0	0
-11	11	1	0	1	1
-10	10	1	0	1	0
-9	9	1	0	0	1
-8	8	1	0	0	0
-7	7	0	1	1	1
-6	6	0	1	1	0
-5	5	0	1	0	1
-4	4	0	1	0	0
-3	3	0	0	1	1
-2	2	0	0	1	0
-1	1	0	0	0	1
0	0	0	0	0	0

■Tone Control Sub Treble (Select Address: 04H)

Sub-Treble Cut or Boost	BCST
	D2
Cut	0
Boost	1

		SUB-TREB	
		D1	D0
Cut Gain(dB)	Boost Gain(dB)		
-3	3	1	1
-2	2	1	0
-1	1	0	1
0	0	0	0

NJW1139A

■BBE-LOW (Lo Contour) / BBE-HIGH (Process) Gain Code (Select Address: 05H)

		BBE-LOW (Lo Contour)				BBE-HIGH (Process)			
Cut Gain(dB)	Boost Gain(dB)	D7	D6	D5	D4	D3	D2	D1	D0
15	FH	1	1	1	1	1	1	1	1
14	EH	1	1	1	0	1	1	1	0
13	DH	1	1	0	1	1	1	0	1
12	CH	1	1	0	0	1	1	0	0
11	BH	1	0	1	1	1	0	1	1
10	AH	1	0	1	0	1	0	1	0
9	9H	1	0	0	1	1	0	0	1
8	8H	1	0	0	0	1	0	0	0
7	7H	0	1	1	1	0	1	1	1
6	6H	0	1	1	0	0	1	1	0
5	5H	0	1	0	1	0	1	0	1
4	4H	0	1	0	0	0	1	0	0
3	3H	0	0	1	1	0	0	1	1
2	2H	0	0	1	0	0	0	1	0
1	1H	0	0	0	1	0	0	0	1
0	0H	0	0	0	0	0	0	0	0

■NOTE

The **NJW1139A** is manufactured by New Japan Radio Co., Ltd. under license from BBE Sound Inc. BBE is a registered trademark of BBE Sound Inc. A license from BBE Sound Inc. is required before the **NJW1139A** can be purchased from New Japan Radio Co.,Ltd. Purchase of I²C components of New Japan Radio Co., Ltd or one of its sublicensed Associated Companiesconveys a license under the Philips I²C Patent Rights to use these components in an I²C system, provided thatthe system conforms to the I²C Standard Specification as defined by Philips.

BBE Sound, Inc.
 5381 Production Drive
 Huntington Beach, CA 92649
 Tel:(714)897-6766
 Fax:(714)896-0736

The TruSurround technology right incorporated in the **NJW1139A** are owned by SRS Labs, a U.S. Corporation and licensed to New Japan Radio Co., Ltd. TruSurround is protected under U.S. and foreign patents issued and/or pending. TruSurround and the  , are trademarks of SRS Labs, Inc. in the United States and selected foreign countries. Neither the purchase of the **NJW1139A**, nor the corresponding sale of audio enhancement equipment conveys the right to sell commercialized recordings made with any SRS technology.

SRS Labs requires that all users of the **NJW1139A** must enter into a license agreement directly with SRS Labs if the royalty is not included in the purchase price. SRS Labs also requires any users to comply with all rules and regulations as outlined in the SRS Trademark Usage Manual.

For further information, please contact:
 SRS Labs, Inc.
 2909 Daimler Street. Santa Ana, CA 92705 USA
 Tel:949-442-1070 Fax:949-852-1099 <http://www.srslabs.com>

[CAUTION]
 The specifications on this databook are only given for information , without any guarantee as regards either mistakes or omissions. The application circuits in this databook are described only to show representative usages of the product and not intended for the guarantee or permission of any right including the industrial rights.