



Audio Processor with BBE

■ GENERAL DESCRIPTION

NJW1146 is an audio processor with BBE, which also includes Master volume, Balance, Tone Control, eala(original surround), Mute, and Output filter amplifier. All of internal status and variables are controlled by I²C BUS.

■ FEATURES

- Operating Voltage 8 to 10 V
- I²C Bus interface
- BBE 0 to +15dB(0.5dB/step)
- eala & simulated stereo
- Master Volume 0 to -80dB, MUTE(0.33dB/step)
- Balance 0 to -30dB, MUTE(1dB/step)
- Tone Control -15 to +15dB(0.5dB/step)
- Bi-CMOS
- Package Outline SDMP30

■ PACKAGE OUTLINE

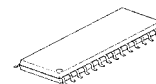

NJW1146M

DataSheet4U.com

DataShee

■ BLOCK DIAGRAM

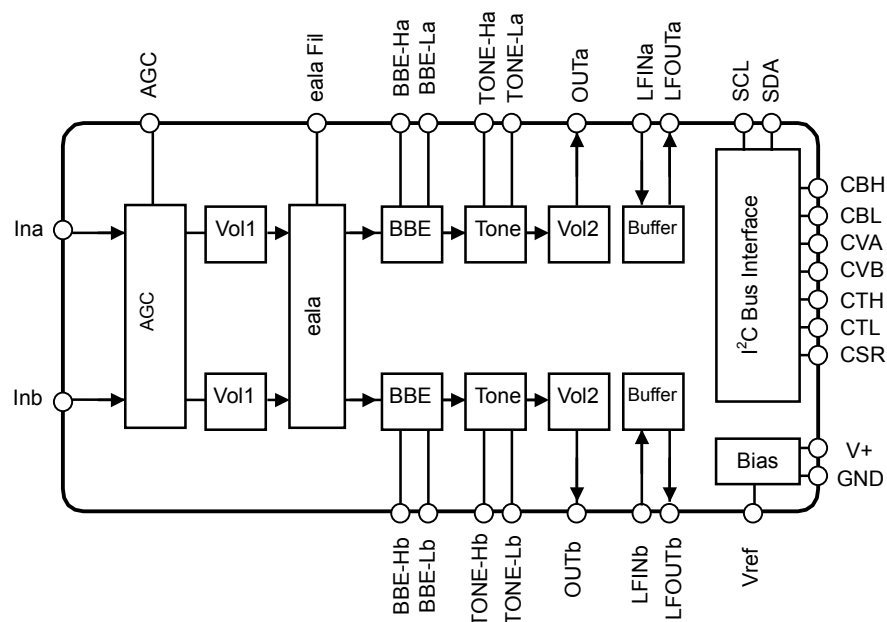

■ PIN FUNCTION

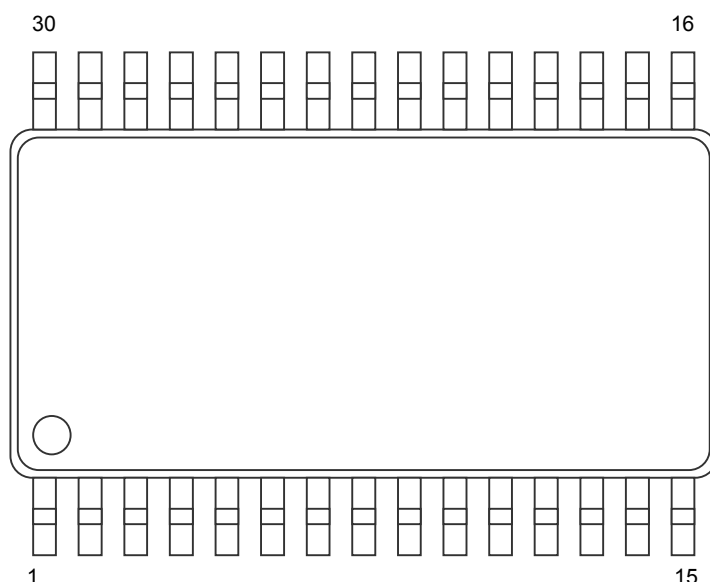

et4U.com

DataSheet4U.com

DataShe

No.	SYMBOL	FUNCTION	No.	SYMBOL	FUNCTION
1	INa	A ch Input	16	V+	Power Supply
2	ealaFil	eala Filter Capacitor	17	VREF	Reference Voltage stabilizing Capacitor
3	BBE1a	Ach BBE High-Pass Filter Capacitor	18	CTL	Tone Control Bass switching noise rejection Capacitor
4	BBE2a	Ach BBE Low-Pass Filter Capacitor	19	CTH	Tone Control Treble switching noise rejection Capacitor
5	TONE-Ha	Ach TONE Treble Filter Capacitor	20	CBL	BBE Low switching noise rejection Capacitor
6	TONE-La	Ach TONE Bass Filter Capacitor	21	CBH	BBE High switching noise rejection Capacitor
7	OUTa	Ach Output	22	LFOUTb	Buffer Output for Bch Low Pass Filter
8	LFINa	Buffer Input for Ach Low Pass Filter	23	LFINb	Buffer Input for Bch Low Pass Filter
9	LFOUTa	Buffer Output for Ach Low Pass Filter	24	OUTb	Bch Output
10	AGC	AGC Smoothing Filter Capacitor	25	TONE-Lb	Bch TONE Bass Filter Capacitor
11	CVA	Ach Volume switching noise rejection Capacitor	26	TONE-Hb	Bch TONE Treble Filter Capacitor
12	CVB	Bch Volume switching noise rejection Capacitor	27	BBE2b	Bch BBE Low-Pass Filter Capacitor
13	SDA	I ² C Data Input	28	BBE1b	Bch BBE High-Pass Filter Capacitor
14	SCL	I ² C Clock Input	29	CSR	eala switching noise rejection Capacitor
15	GND	Ground	30	INb	B ch Input

■ ABSOLUTE MAXIMUM RATING (Ta=25°C)

PARAMETER	SYMBOL	RATING	UNIT
Supply Voltage	V ⁺	12	V
Power Dissipation	P _D	700	mW
Operating Temperature Range	Topr	-20 to +75	°C
Storage Temperature Range	Tstg	-40 to +125	°C

**■ ELECTRICAL CHARACTERISTICS (Ta=25°C, V⁺=9V, R_L=47kΩ, Vin=100mVrms/1kHz
MODE ; VOL=0dB, BAL=0dB, AGC=OFF, BBE=OFF, Tone=0dB, eala=By-Pass)**

PARAMETER	SYMBOL	TEST CONDITION	MIN.	TYP.	MAX.	UNIT
Operating Voltage	V ⁺		8.0	9.0	10.0	V
Supply Current	I _{CC}	No Signal	-	25	35	mA
Reference Voltage	V _{REF}	No Signal	4.0	4.5	5.0	V
Maximum Input Voltage	V _{IM}	VOL=-20dB, THD=10%	2.8	3.0	-	Vrms
Maximum Output Voltage	V _{OM}	OUTPUT VOL=0dB, THD=1%	-	2.5	-	Vrms
Channel Balance	G _{CB}	VOL=0dB	-1.5	0.0	1.5	dB
Balance Boost A	G _{BBA}	CHS="0", BAL=Mute	-2.0	0.0	2.0	dB
Balance Cut A	G _{BCA}	CHS="1", BAL=Mute Vin = 1Vrms	-	-	-70	dB
Balance Boost B	G _{BBB}	CHS="1", BAL=Mute	-2.0	0.0	2.0	dB
Balance Cut B	G _{BCB}	CHS="0", BAL=Mute Vin = 1Vrms	-	-	-70	dB
Total Harmonic Distortion	THD	Vo=0.5Vrms BW=400Hz to 30kHz	-	-	0.5	%
Maximum Voltage Gain	G _{VMAX}	VOL= 0dB	-2.0	0.0	2.0	dB
Minimum Voltage Gain	G _{VMIN}	VOL= Mute	-	-	-70	dB
Channel Separation	CS	Vin = 1Vrms	-	-	-70	dB
Output Noise 1	V _{NO1}	VOL = 0dB BW=400Hz to 30kHz	-	-90 (31.6)	-85 (56.2)	dBV (μVrms)
Output Noise 2	V _{NO2}	VOL = Mute BW = 400Hz to 30kHz	-	-106 (5.0)	-96 (15.8)	dBV (μVrms)

BW : Band Width

**◆ TONE CONTROL CHARACTERISTICS (Ta=25°C, V⁺=9V, R_L=47kΩ, Vin=100mVrms/1kHz
MODE ; VOL=0dB, BAL=0dB, AGC=OFF, BBE=OFF, eala=By-Pass)**

PARAMETER	SYMBOL	TEST CONDITION	MIN.	TYP.	MAX.	UNIT
Treble Boost Gain	G _{HFBST}	TREB=+15dB, f=10kHz	12.5	15.0	17.5	dB
Treble Boost Flat	G _{HFFLT}	TREB=0dB, f=10kHz	-2.0	0.0	2.0	dB
Treble Boost Cut	G _{HFCUT}	TRBE=-15dB, f=10kHz	-17.5	-15.0	-12.5	dB
Bass Boost Gain	G _{LFBST}	BASS=+15dB, f=100Hz	12.5	15.0	17.5	dB
Bass Boost Flat	G _{LFFLT}	BASS=0dB, f=100Hz	-2.0	0.0	2.0	dB
Bass Boost Cut	G _{LF CUT}	BASS=-15dB, f=100Hz	-17.5	-15.0	-12.5	dB

◆ **AGC CHARACTERISTICS** (Ta=25°C, V⁺=9V, R_L=47kΩ
MODE ; VOL=0dB, BAL=0dB, AGC=ON, BBE=OFF, Tone=0dB, eala=By-Pass)

PARAMETER	SYMBOL	TEST CONDITION	MIN.	TYP.	MAX.	UNIT
AGC Boost	G _{AGCBST}	Vin=50mVrms, f=1kHz	1.5	3.5	5.5	dB
AGC Flat 1	G _{AGCFLT1}	Vin=300mVrms, f=1kHz	-2.5	0.0	2.5	dB
AGC Flat 2	G _{AGCFLT2}	Vin=400mVrms, f=1kHz	-2.5	0.0	2.5	dB
AGC Flat 3	G _{AGCFLT3}	Vin=500mVrms, f=1kHz	-2.5	0.0	2.5	dB
AGC Flat 4	G _{AGCFLT4}	Vin=600mVrms, f=1kHz	-2.5	0.0	2.5	dB
AGC Cut	G _{AGCCUT}	Vin=2Vrms, f=1kHz	-14	-10	-6.0	dB

◆ **BBE CHARACTERISTICS** (Ta=25°C, V⁺=9V, R_L=47kΩ, Vin=100mVrms/1kHz
MODE ; VOL=0dB, BAL=0dB, AGC=OFF, Tone=0dB, eala=By-Pass)

PARAMETER	SYMBOL	TEST CONDITION	MIN.	TYP.	MAX.	UNIT
Low Boost Gain	G _{BBELOW}	BBE-LOW =+15dB, f=50Hz	12.5	15	17.5	dB
High Boost Gain	G _{BBEHIGH}	BBE-HIGH =+15dB, f=10kHz	12.5	15	17.5	dB

◆ **eala CHARACTERISTICS** (Ta=25°C, V⁺=9V, R_L=47kΩ, Vin=100mVrms/1kHz
MODE ; VOL=0dB, BAL=0dB, AGC=OFF, BBE=0dB, Tone=0dB)

PARAMETER	SYMBOL	TEST CONDITION	MIN.	TYP.	MAX.	UNIT
Simulated Stereo A	G _{SIMA}	LIN+RIN→OUTa, f=1KHz, SIM	1.0	3.0	5.0	dB
Simulated Stereo B	G _{SIMB}	LIN+RIN→OUTb, f=1KHz, SIM	1.0	3.0	5.0	dB
Surround 3D1	G _{3D1}	LIN→OUTa, f=100Hz, SR2	5.5	7.5	9.5	dB
Surround 3D2	G _{3D2}	LIN→OUTa, f=10KHz, SR2	-2.0	0.0	2.0	dB
Surround 3D3	G _{3D3}	LIN→OUTb, f=100Hz, SR2	0.5	2.5	4.5	dB
Surround 3D4	G _{3D4}	LIN→OUTa, f=100Hz, SR1	3.5	5.5	7.5	dB

■ **I²C BUS CHARACTERISTICS (SDA, SCL)** DataSheet4U.com

I²C BUS Load Conditions: Pull up resistance 4kΩ(Connected to +5V), Load capacitance 200pF (Connected to GND)

PARAMETER	SYMBOL	MIN.	TYP.	MAX.	UNIT
High Level Input Voltage	V _{IH}	3.0	-	5.0	V
Low Level Input Voltage	V _{IL}	0	-	1.5	V
High Level Input Current	I _{IH}	-	-	10	μA
Low Level Input Current	I _{IL}	-	-	10	μA
Low Level Output Voltage (3mA at SDA pin)	V _{OL}	0	-	0.4	V
Maximum Output Current	I _{OL}	-3.0	-	-	mA
Maximum Clock Frequency	f _{SCL}	0	-	100	kHz
Data Change Minimum Waiting Time	t _{BUF}	4.7	-	-	μs
Data Transfer Start Minimum Waiting Time	t _{HD:STA}	4.0	-	-	μs
Low Level Clock Pulse Width	t _{LOW}	4.7	-	-	μs
High Level Clock Pulse Width	T _{HIGH}	4.0	-	-	μs
Minimum Start Preparation Waiting Time	t _{SU:STA}	4.7	-	-	μs
Minimum Data Hold Time	t _{HD:DAT}	5.0	-	-	μs
Minimum Data Preparation Time	t _{SU:DAT}	250	-	-	ns
Rise Time	t _R	-	-	1.0	μs
Fall Time	t _F	-	-	300	ns
Minimum Stop Preparation Waiting Time	t _{SU:STO}	4.7	-	-	μs

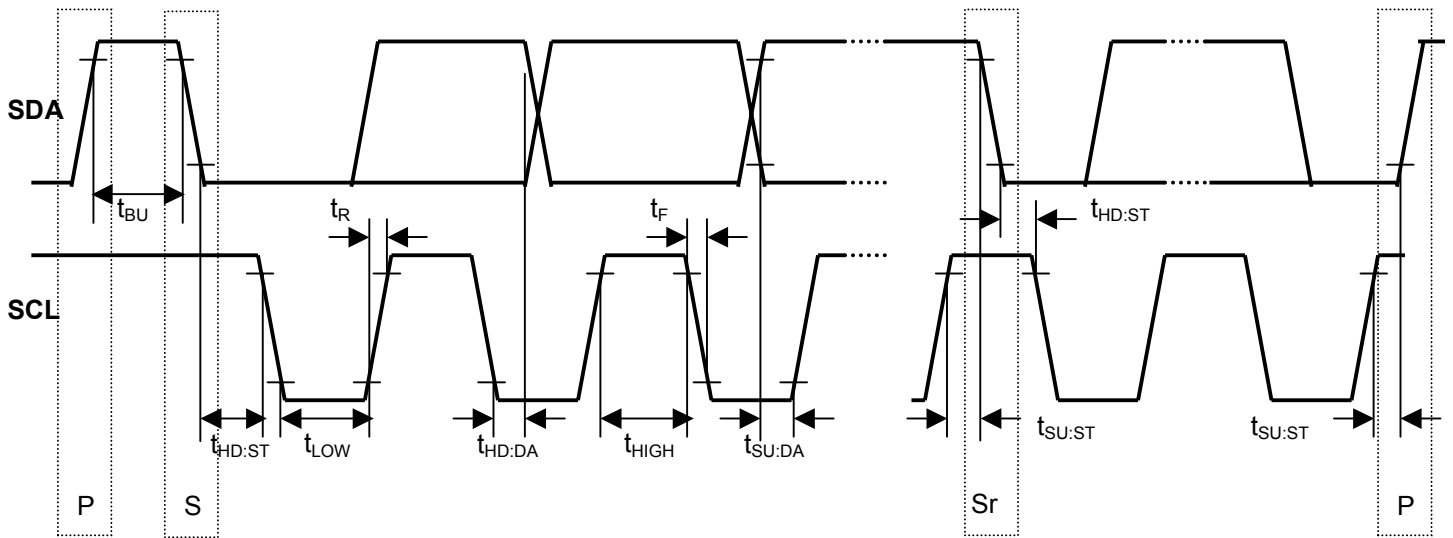

NJW1146

PRELIMINARY

■ APPLICATION CIRCUIT 1 (Bi-Amp outputs)

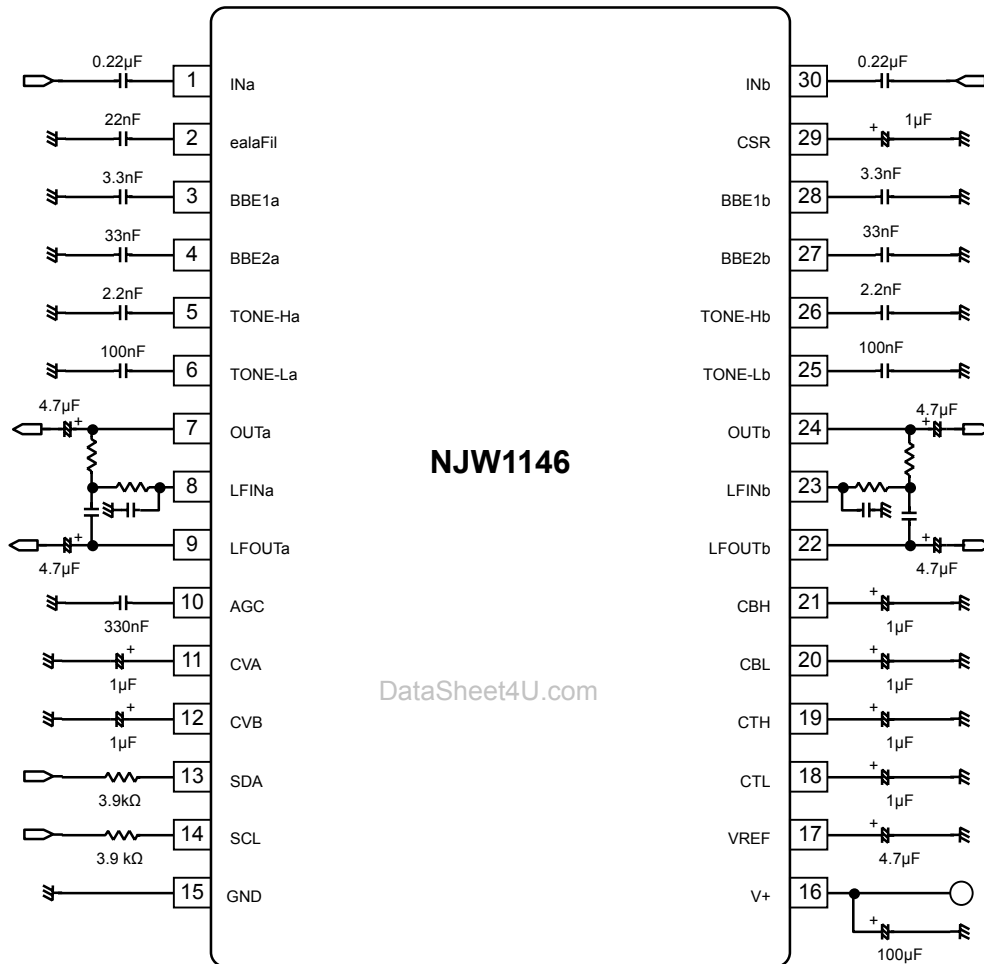

et4U.com

DataSheet4U.com

DataShee

■ APPLICATION CIRCUIT 2 (Sub-Woofer output)

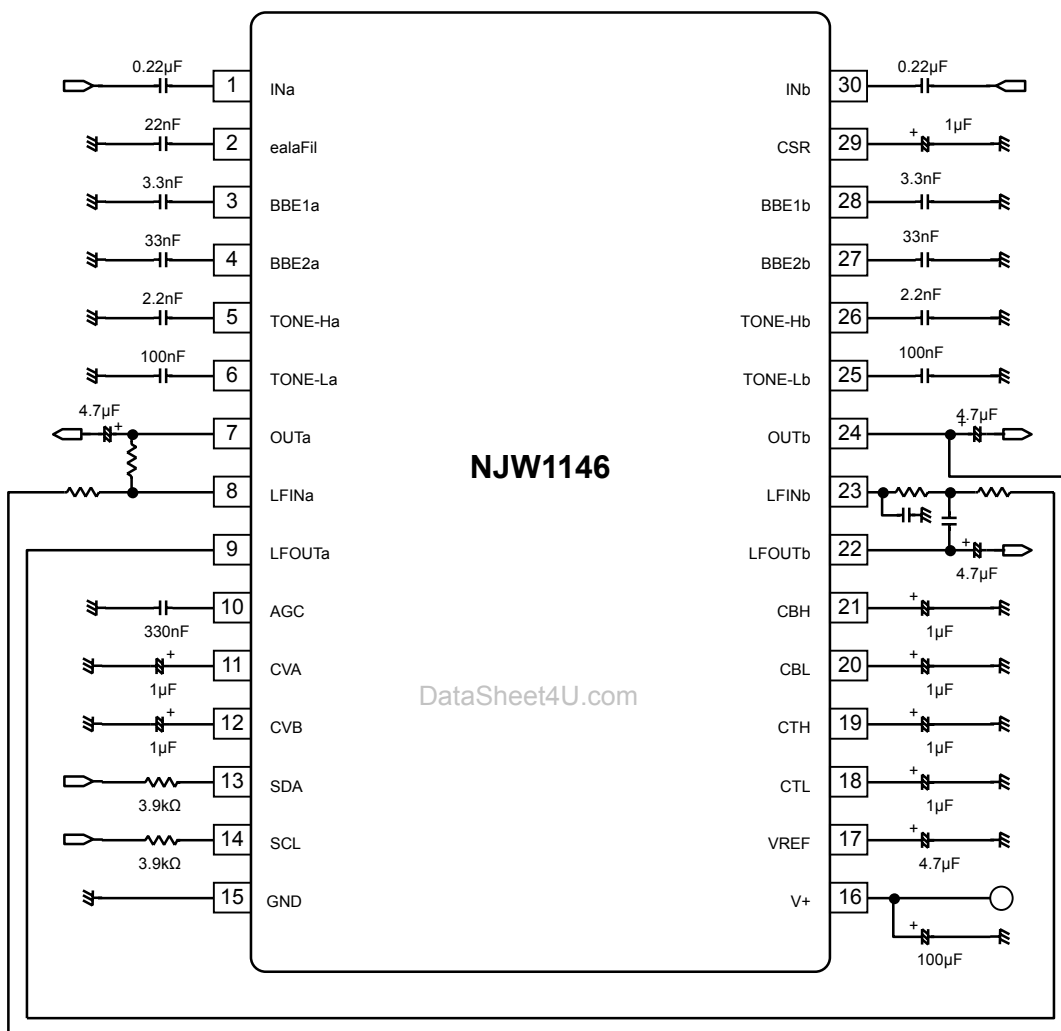

et4U.com

DataShee

< Output Type >

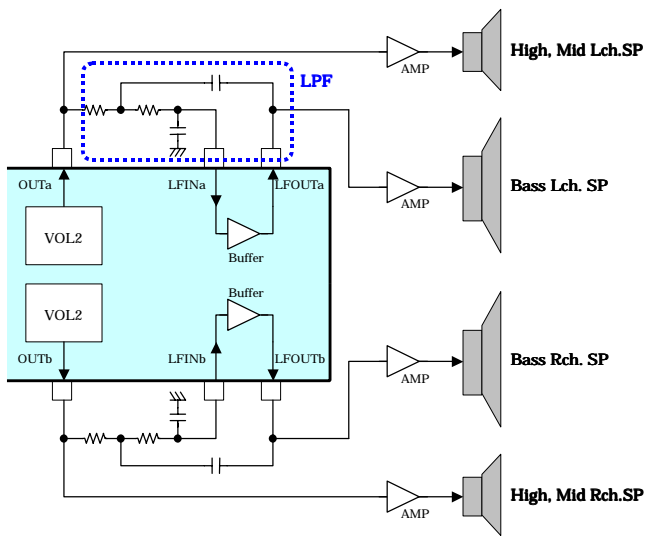

Fig 1. Bi-Amp

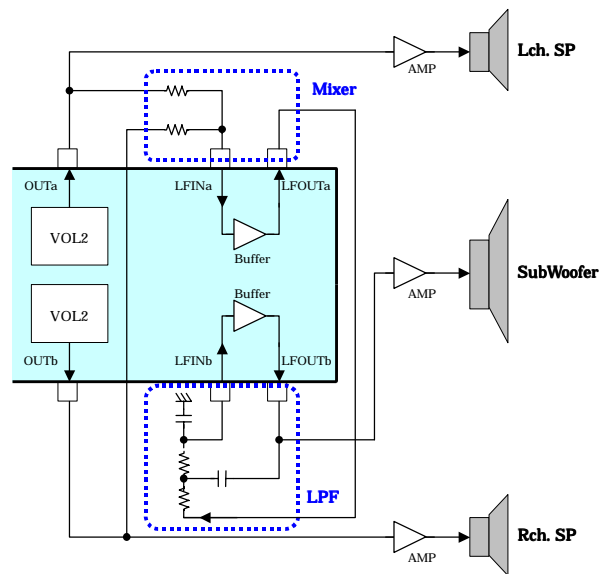
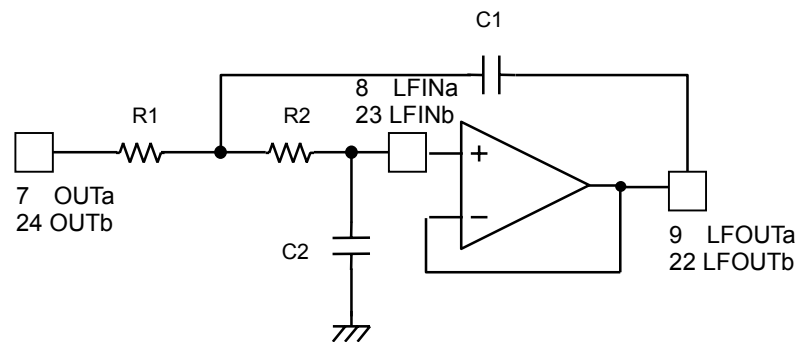

Fig 2. Sub-Woofers

< OUT, LFIN, LFOUT Low Pass Filter Setting >

LPF cut off frequency and quality factor are adjusted by the external parts and given by the following functions.



$$f_c = \frac{1}{2\pi\sqrt{R1 \cdot R2 \cdot C1 \cdot C2}} \text{ (Hz)}$$

$$Q = \frac{1}{\sqrt{\frac{C2 \cdot R1}{C1 \cdot R2}} + \sqrt{\frac{C1 \cdot R2}{C2 \cdot R1}}}$$

■ TERMINAL DESCRIPTION

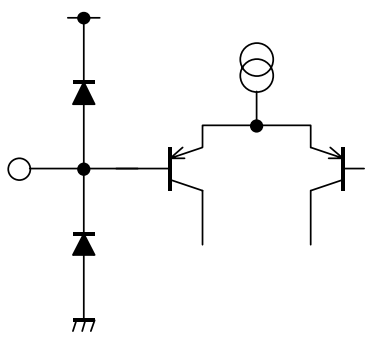
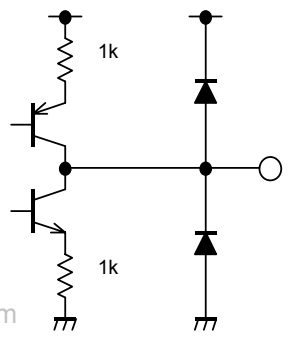
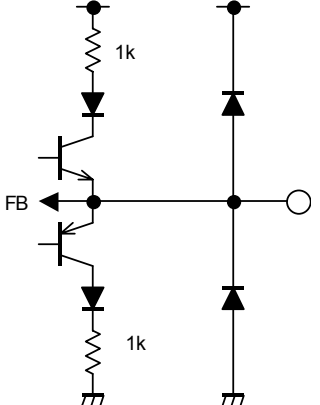
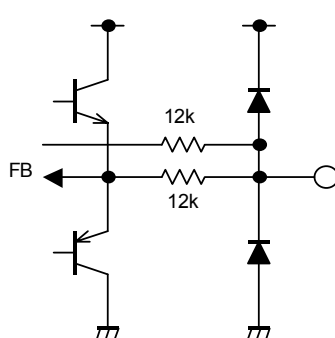
PIN NO.	SYMBOL	FUNCTION	EQUIVALENT CIRCUIT	TERMINAL VOLTAGE
1 2 8 23 30	INa ealaFil LFINa LFINb INb	A ch Input eala Filter Capacitor Buffer Input for Ach Low Pass Filter Buffer Input for Bch Low Pass Filter B ch Input		V+/2
3 4 27 28	BBE1a BBE2a BBE2b BBE1b	Ach BBE High-Pass Filter Capacitor Ach BBE Low-Pass Filter Capacitor Bch BBE Low-Pass Filter Capacitor Bch BBE High-Pass Filter Capacitor		V+/2
5 26	TONE-Ha TONE-Hb	Ach TONE Treble Filter Capacitor Bch TONE Treble Filter Capacitor		V+/2
6 25	TONE-La TONE-Lb	Ach TONE Bass Filter Capacitor Bch TONE Bass Filter Capacitor		V+/2

et4U.com

DataSheet4U.com

DataShee

■ TERMINAL DESCRIPTION

PIN NO.	SYMBOL	FUNCTION	EQUIVALENT CIRCUIT	TERMINAL VOLTAGE
7 9 22 24	OUTa LFOUTa LFOUTb OUTb	Ach Output Buffer Output for Ach Low Pass Filter Buffer Output for Bch Low Pass Filter Bch Output		V+/2
10	AGC	AGC Smoothing Filter Capacitor		-
11 12	CVA CVB	Ach Volume switching noise rejection Capacitor Bch Volume switching noise rejection Capacitor		VREF-0.7V
13 14	SDA SCL	I ² C Data Input I ² C Clock Input		-

et4U.com

DataSheet4U.com

DataShee

■ TERMINAL DESCRIPTION

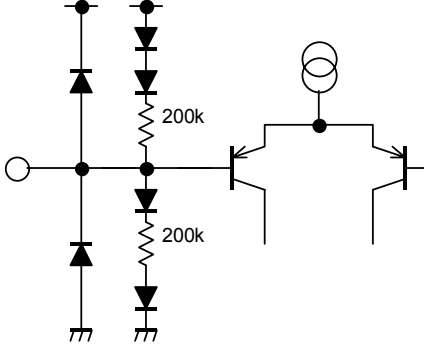
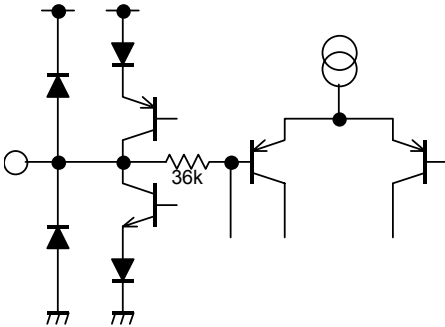
PIN NO.	SYMBOL	FUNCTION	EQUIVALENT CIRCUIT	TERMINAL VOLTAGE
15	GND	Ground	-	-
16	V+	Power Supply	-	V+
17	VREF	Reference Voltage Capacitor		V+/2
18	CTL	Tone Control Bass switching noise rejection Capacitor		VREF-0.7V
19	CTH	Tone Control Treble switching noise rejection Capacitor		

■ TERMINAL DESCRIPTION

PIN NO.	SYMBOL	FUNCTION	EQUIVALENT CIRCUIT	TERMINAL VOLTAGE
20 21	CBL CBH	BBE Low switching noise rejection Capacitor BBE High switching noise rejection Capacitor		VREF-0.7V
29	CSR	eala switching noise rejection Capacitor		0.54V(CSR) 1.4V(CTS2)

et4U.com

DataSheet4U.com

DataShee

■ DEFINITION OF I²C REGISTER

● I²C BUS FORMAT



S: Starting Term

A: Acknowledge Bit

P: Ending Term

● SLAVE ADDRESS



● CONTROL REGISTER TABLE

The select address sets each function (Volume, Balance, Bass Boost Select, AGC, Surround, Tone Control).

The auto-increment function cycles the select address as follows.

00H→01H→02H→03H→04H→05H→06H→00H

Select Address	BIT							
	D7	D6	D5	D4	D3	D2	D1	D0
00H	VOL							
01H	CHS	BAL					Don't Care	
02H	BCB	BASS					Don't Care	
03H	BCT	TREB					Don't Care	
04H	BBEL					BBE	Don't Care	
05H	BBEH					AGC	AGC LVL	
06H	eala		Don't Care					

● CONTROL REGISTER DEFAULT VALUE

Control register default value is all "0".

Select Address	BIT							
	D7	D6	D5	D4	D3	D2	D1	D0
00H	0	0	0	0	0	0	0	0
01H	0	0	0	0	0	0	0	0
02H	0	0	0	0	0	0	0	0
03H	0	0	0	0	0	0	0	0
04H	0	0	0	0	0	0	0	0
05H	0	0	0	0	0	0	0	0
06H	0	0	0	0	0	0	0	0

● CONTROL COMMAND TABLE

a) Master Volume

Select Address	BIT							
	D7	D6	D5	D4	D3	D2	D1	D0
00H	VOL							

●VOL : Master Volume

Attenuation level : 0 to -80dB(0.33dB/step), MUTE

The volume is consisted of VOL1 and VOL2 and the level is divided into half to each VOL1 and VOL2.

ex) Volume setting is -2dB ; VOL1 and VOL2 is set -1dB each.

b) Balance

Select Address	BIT							
	D7	D6	D5	D4	D3	D2	D1	D0
01H	CHS	BAL					Don't Care	

●CHS : Balance channel select

"0" : Ach "Bch is attenuated"

"1" : Bch "Ach is attenuated"

●BAL : Ach and Bch Balance

Balance Level : 0 to -30dB (1dB/Step) , MUTE

c) Tone Control BASS

Select Address	BIT							
	D7	D6	D5	D4	D3	D2	D1	D0
03H	BCB	BASS					Don't Care	

●BCB : Bass Boost or Cut

"0" : Cut

"1" : Boost

●BASS : BASS Level

Cut Level : -15 to 0dB(0.5dB/Step)

Boost Level : 0 to +15dB(0.5dB/Step)

e) Tone Control TREBLE

Select Address	BIT							
	D7	D6	D5	D4	D3	D2	D1	D0
04H	BCT	TREB					Don't Care	

●BCT : Treble Boost or Cut

"0" : Cut

"1" : Boost

●TREB : Treble Level

Cut Level : -15 to 0dB(0.5dB/Step)

Boost Level : 0 to +15dB(0.5dB/Step)

f) BBE-Low

Select Address	BIT							
	D7	D6	D5	D4	D3	D2	D1	D0
05H	BBEL					BBE	Don't Care	

●BBEL:BBE-LOW Level

0dB to 15dB (0.5dB/step)

All bit "0"(00H)= BBE OFF

●BBE : BBE ON or OFF

g) BBE-High

Select Address	BIT							
	D7	D6	D5	D4	D3	D2	D1	D0
05H	BBEH					AGC	AGC LVL	

•BBEH: BBE-HIGH Level

0dB to 15dB (0.5dB/step)

All bit "0"(00H)= BBE OFF

•AGC : AGC ON or OFF

•AGC LVL : AGC Level

300mVrms, 400mVrms, 500mVrms, 600mVrms

h) Surround (eala)

Select Address	BIT							
	D7	D6	D5	D4	D3	D2	D1	D0
06H	eala		Don't Care					

•eala : eala mode

Surround effect small (SR1), large (SR2), Simulated Stereo (SIM), By-Pass

■ Master Volume (Select Address: 00H)

		VOL							
Gain(dB)	HEX	D7	D6	D5	D4	D3	D2	D1	D0
0	FF	1	1	1	1	1	1	1	1
-1	FC	1	1	1	1	1	1	0	0
-2	F9	1	1	1	1	1	0	0	1
-3	F6	1	1	1	1	0	1	1	0
-4	F3	1	1	1	1	0	0	1	1
-5	F0	1	1	1	1	0	0	0	0
-6	ED	1	1	1	0	1	1	0	1
-7	EA	1	1	1	0	1	0	1	0
-8	E7	1	1	1	0	0	1	1	1
-9	E4	1	1	1	0	0	1	0	0
-10	E1	1	1	1	0	0	0	0	1
-11	DE	1	1	0	1	1	1	1	0
-12	DB	1	1	0	1	1	0	1	1
-13	D8	1	1	0	1	1	0	0	0
-14	D5	1	1	0	1	0	1	0	1
-15	D2	1	1	0	1	0	0	1	0
-16	CF	1	1	0	0	1	1	1	1
-17	CC	1	1	0	0	1	1	0	0
-18	C9	1	1	0	0	1	0	0	1
-19	C6	1	1	0	0	0	1	1	0
-20	C3	1	1	0	0	0	0	1	1
-21	C0	1	1	0	0	0	0	0	0
-22	BD	1	0	1	1	1	1	0	1
-23	BA	1	0	1	1	1	0	1	0
-24	B7	1	0	1	1	0	1	1	1
-25	B4	1	0	1	1	0	1	0	0
-26	B1	1	0	1	1	0	0	0	1
-27	AE	1	0	1	0	1	1	1	0
-28	AB	1	0	1	0	1	0	1	1
-29	A8	1	0	1	0	1	0	0	0
-30	A5	1	0	1	0	0	1	0	1
-31	A2	1	0	1	0	0	0	1	0
-32	9F	1	0	0	1	1	1	1	1
-33	9C	1	0	0	1	1	1	0	0
-34	99	1	0	0	1	1	0	0	1
-35	96	1	0	0	1	0	1	1	0
-36	93	1	0	0	1	0	0	1	1
-37	90	1	0	0	1	0	0	0	0
-38	8D	1	0	0	0	1	1	0	1
-39	8A	1	0	0	0	1	0	1	0
-40	87	1	0	0	0	0	1	1	1
-41	84	1	0	0	0	0	1	0	0
-42	81	1	0	0	0	0	0	0	1

		VOL							
Gain(dB)	HEX	D7	D6	D5	D4	D3	D2	D1	D0
-43	7E	0	1	1	1	1	1	1	0
-44	7B	0	1	1	1	1	0	1	1
-45	78	0	1	1	1	1	0	0	0
-46	75	0	1	1	1	0	1	0	1
-47	72	0	1	1	1	0	0	1	0
-48	6F	0	1	1	0	1	1	1	1
-49	6C	0	1	1	0	1	1	0	0
-50	69	0	1	1	0	1	0	0	1
-51	66	0	1	1	0	0	1	1	0
-52	63	0	1	1	0	0	0	1	1
-53	60	0	1	1	0	0	0	0	0
-54	5D	0	1	0	1	1	1	0	1
-55	5A	0	1	0	1	1	0	1	0
-56	57	0	1	0	1	0	1	1	1
-57	54	0	1	0	1	0	1	0	0
-58	51	0	1	0	1	0	0	0	1
-59	4E	0	1	0	0	1	1	1	0
-60	4B	0	1	0	0	1	0	1	1
-61	48	0	1	0	0	1	0	0	0
-62	45	0	1	0	0	0	1	0	1
-63	42	0	1	0	0	0	0	1	0
-64	3F	0	0	1	1	1	1	1	1
-65	3C	0	0	1	1	1	1	0	0
-66	39	0	0	1	1	1	0	0	1
-67	36	0	0	1	1	0	1	1	0
-68	33	0	0	1	1	0	0	1	1
-69	30	0	0	1	1	0	0	0	0
-70	2D	0	0	1	0	1	1	0	1
-71	2A	0	0	1	0	1	0	1	0
-72	27	0	0	1	0	0	1	1	1
-73	24	0	0	1	0	0	1	0	0
-74	21	0	0	1	0	0	0	0	1
-75	1E	0	0	0	1	1	1	1	0
-76	1B	0	0	0	1	1	0	1	1
-77	18	0	0	0	1	1	0	0	0
-78	15	0	0	0	1	0	1	0	1
-79	12	0	0	0	1	0	0	1	0
-80	0F	0	0	0	0	1	1	1	1
Mute	00	0	0	0	0	0	0	0	0

■ Balance (Select Address: 01H)

Channel Setting (CHS)	D7
Attenuated Bch Gain	0
Attenuated Ach Gain	1

Gain(dB)	BAL				
	D6	D5	D4	D3	D2
0	0	0	0	0	0
-1	0	0	0	0	1
-2	0	0	0	1	0
-3	0	0	0	1	1
-4	0	0	1	0	0
-5	0	0	1	0	1
-6	0	0	1	1	0
-7	0	0	1	1	1
-8	0	1	0	0	0
-9	0	1	0	0	1
-10	0	1	0	1	0
-11	0	1	0	1	1
-12	0	1	1	0	0
-13	0	1	1	0	1
-14	0	1	1	1	0
-15	0	1	1	1	1
-16	1	0	0	0	0
-17	1	0	0	0	1
-18	1	0	0	1	0
-19	1	0	0	1	1
-20	1	0	1	0	0
-21	1	0	1	0	1
-22	1	0	1	1	0
-23	1	0	1	1	1
-24	1	1	0	0	0
-25	1	1	0	0	1
-26	1	1	0	1	0
-27	1	1	0	1	1
-28	1	1	1	0	0
-29	1	1	1	0	1
-30	1	1	1	1	0
MUTE	1	1	1	1	1

■ Tone Control Bass (Select Address: 02H)

Bass Cut or Boost	BCB
	D7
Cut	0
Boost	1

		BASS				
Cut Gain(dB)	Boost Gain(dB)	D6	D5	D4	D3	D2
-15	15	1	1	1	1	0
-14	14	1	1	1	0	0
-13	13	1	1	0	1	0
-12	12	1	1	0	0	0
-11	11	1	0	1	1	0
-10	10	1	0	1	0	0
-9	9	1	0	0	1	0
-8	8	1	0	0	0	0
-7	7	0	1	1	1	0
-6	6	0	1	1	0	0
-5	5	0	1	0	1	0
-4	4	0	1	0	0	0
-3	3	0	0	1	1	0
-2	2	0	0	1	0	0
-1	1	0	0	0	1	0
0	0	0	0	0	0	0

■ Tone Control Treble (Select Address: 03H)

Treble Cut or Boost	BCT
	D7
Cut	0
Boost	1

		TREB				
Cut Gain(dB)	Boost Gain(dB)	D6	D5	D4	D3	D2
-15	15	1	1	1	1	0
-14	14	1	1	1	0	0
-13	13	1	1	0	1	0
-12	12	1	1	0	0	0
-11	11	1	0	1	1	0
-10	10	1	0	1	0	0
-9	9	1	0	0	1	0
-8	8	1	0	0	0	0
-7	7	0	1	1	1	0
-6	6	0	1	1	0	0
-5	5	0	1	0	1	0
-4	4	0	1	0	0	0
-3	3	0	0	1	1	0
-2	2	0	0	1	0	0
-1	1	0	0	0	1	0
0	0	0	0	0	0	0

■ BBE-LOW Gain Code (Select Address: 04H)

Gain(dB)	BBEL				
	D7	D6	D5	D4	D3
15	1	1	1	1	0
14	1	1	1	0	0
13	1	1	0	1	0
12	1	1	0	0	0
11	1	0	1	1	0
10	1	0	1	0	0
9	1	0	0	1	0
8	1	0	0	0	0
7	0	1	1	1	0
6	0	1	1	0	0
5	0	1	0	1	0
4	0	1	0	0	0
3	0	0	1	1	0
2	0	0	1	0	0
1	0	0	0	1	0
0	0	0	0	0	0

■ BBE (Select Address: 04H)

BBE ON/OFF	BBE
	D2
OFF	0
ON	1

DataSheet4U.com

DataShee

■ BBE-HIGH Gain Code (Select Address: 05H)

Gain(dB)	BBEH				
	D7	D6	D5	D4	D3
15	1	1	1	1	0
14	1	1	1	0	0
13	1	1	0	1	0
12	1	1	0	0	0
11	1	0	1	1	0
10	1	0	1	0	0
9	1	0	0	1	0
8	1	0	0	0	0
7	0	1	1	1	0
6	0	1	1	0	0
5	0	1	0	1	0
4	0	1	0	0	0
3	0	0	1	1	0
2	0	0	1	0	0
1	0	0	0	1	0
0	0	0	0	0	0

■ AGC (Select Address: 05H)

AGC ON/OFF	AGC
	D2
OFF	0
ON	1

■ AGC Level (Select Address: 05H)

AGC Level	AGC LVL	
	D1	D0
300mVrms	0	0
400mVrms	0	1
500mVrms	1	0
600mVrms	1	1

■ eala mode (Select Address: 06H)

eala MODE	eala	
	D7	D6
By-Pass	0	0
Simulated Stereo	0	1
3D Effect Large	1	0
3D Effect Small	1	1

■NOTE

DataSheet4U.com

The **NJW1146** is manufactured by New Japan Radio Co., Ltd. under license from BBE Sound Inc. BBE is a registered trademark of BBE Sound Inc. A license from BBE Sound Inc. is required before the **NJW1146** can be purchased from New Japan Radio Co.,Ltd.

BBE Sound, Inc.
5381 Production Drive
Huntington Beach, CA 92649
Tel:(714) 897-6766
Fax:(714) 896-0736

Purchase of I²C components of New Japan Radio Co., Ltd or one of its sublicensed Associated Companies conveys a license under the Philips I²C Patent Rights to use these components in an I²C system, provided that the system conforms to the I²C Standard Specification as defined by Philips.

[CAUTION]

The specifications on this data book are only given for information, without any guarantee as regards either mistakes or omissions. The application circuits in this data book are described only to show representative usages of the product and not intended for the guarantee or permission of any right including the industrial rights.