



## Audio Processor with Sound Enhancement and TruSurround 5.1ch Virtualizer

### ■ GENERAL DESCRIPTION

The **NJW1149A** is an audio processor with BBE sound enhancement and SRS Labs' TruSurround 5.1 channel virtualizer. It includes all of functions processing audio signal for TV, such as volume, balance, mute, tone control, eala NJRC surround and simulated stereo functions. All of internal status and variables are controlled by I<sup>2</sup>C BUS.

The NJW1149 is available for Virtual Dolby Surround or Virtual Dolby Digital with Dolby Pro Logic or Dolby Digital system\*.

### ■ PACKAGE OUTLINE

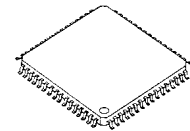

NJW1149AFH1

\*For use in Virtual Dolby Surround(VDS) and/or Virtual Dolby Digital(VDD) products, please contact Dolby Laboratories for licensing information. Dolby and the double-D symbol are trademarks of Dolby Laboratories Licensing Corporation. Licensing and application information may be obtained from Dolby Lab.

### ■ FEATURES

- Operating Voltage      8 to 10 V
- I<sup>2</sup>C BUS Interface
- TruSurround 5.1ch. / 4ch. / 2ch. Inputs
- BBE                      0dB to +15dB(0.5dB/step)
- eala (surround effect ; 2 steps) and Simulated Stereo
- Volume                 0 to -80dB, MUTE (0.33dB/step)
- Balance                 0 to -30dB, MUTE (1dB/step)
- Tone Control           -15dB to +15dB(0.5dB/step)
- Bi-CMOS Technology
- Package Outline        QFP64-H1

### ■ BLOCK DIAGRAM

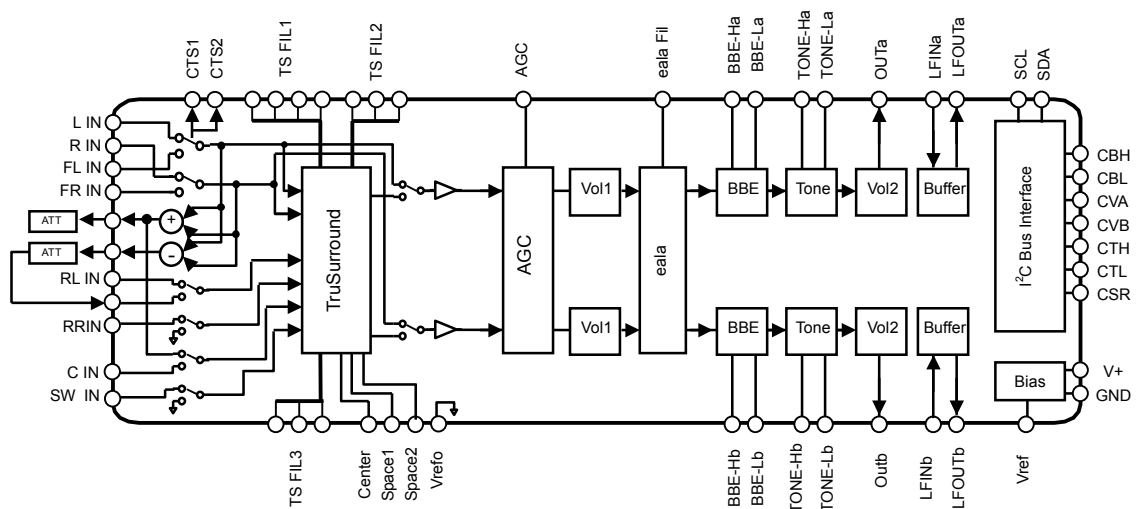

# NJW1149A

www.DataSheet4U.com

## ■ PIN FUNCTION

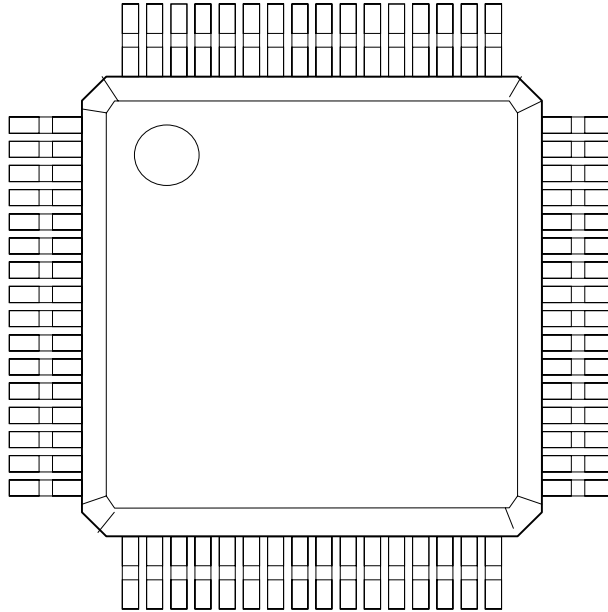

No.	SYMBOL	FUNCTION	No.	SYMBOL	FUNCTION
1	TS12	TruSurround Filter Capacitor 12	33	CBH	BBE High switching noise rejection Capacitor
2	TS13	TruSurround Filter Capacitor 13	34	LFOUtb	Buffer Output for Bch Low Pass Filter
3	TS14	TruSurround Filter Capacitor 14	35	LFINb	Buffer Input for Bch Low Pass Filter
4	SPACE1	SPACE Volume1	36	OUTb	Bch Output
5	SPACE2	SPACE Volume2	37	TONE-Lb	Bch TONE Bass Filter Capacitor
6	CENTER	CENTER Volume	38	TONE-Hb	Bch TONE Treble Filter Capacitor
7	VREFO	Reference Voltage Output Capacitor	39	BBE2b	Bch BBE Low-Pass Filter Capacitor
8	ealaFil	eala Filter Capacitor	40	BBE1b	Bch BBE High-Pass Filter Capacitor
9	BBE1a	Ach BBE High-Pass Filter Capacitor	41	CSR	eala switching noise rejection Capacitor
10	BBE2a	Ach BBE Low-Pass Filter Capacitor	42	N.C.	No Connection
11	TONE-Ha	Ach TONE Treble Filter Capacitor	43	CTS2	TruSurround switching noise rejection Capacitor 2
12	TONE-La	Ach TONE Bass Filter Capacitor	44	CTS1	TruSurround switching noise rejection Capacitor 1
13	OUTa	Ach Output	45	TS33	TruSurround Filter Capacitor 33
14	LFINa	Buffer Input for Ach Low Pass Filter	46	TS32	TruSurround Filter Capacitor 32
15	LFOUta	Buffer Output for Ach Low Pass Filter	47	TS31	TruSurround Filter Capacitor 31
16	AGC	AGC Smoothing Filter Capacitor	48	ATTC	Center Attenuation Resistor
17	CVA	Ach Volume switching noise rejection Capacitor	49	N.C.	No Connection
18	CVB	Bch Volume switching noise rejection Capacitor	50	ATTS2	Surround Attenuation Resistor 2
19	SDA	I <sup>2</sup> C Data Input	51	ATTS1	Surround Attenuation Resistor 1
20	SCL	I <sup>2</sup> C Clock Input	52	TS23	TruSurround Filter Capacitor 23
21	GND	Ground	53	TS22	TruSurround Filter Capacitor 22
22	N.C.	No Connection	54	TS21	TruSurround Filter Capacitor 21
23	N.C.	No Connection	55	SWIN	SW ch Input
24	N.C.	No Connection	56	CIN	C ch Input
25	N.C.	No Connection	57	RRIN	Rear-R ch Input
26	N.C.	No Connection	58	RLIN	Rear-L ch Input
27	N.C.	No Connection	59	FRIN	Front-R ch Input
28	V+	Power Supply	60	FLIN	Front-L ch Input
29	VREF	Reference Voltage stabilizing Capacitor	61	RIN	R ch Input
30	CTL	Tone Control Bass switching noise rejection Capacitor	62	LIN	L ch Input
31	CTH	Tone Control Treble switching noise rejection Capacitor	63	TS11	TruSurround Filter Capacitor 21
32	CBL	BBE Low switching noise rejection Capacitor	64	N.C.	No Connection

**■ ABSOLUTE MAXIMUM RATING (Ta=25°C)**

PARAMETER	SYMBOL	RATING	UNIT
Supply Voltage	V <sup>+</sup>	12	V
Power Dissipation	P <sub>D</sub>	1400*	mW
Operating Temperature Range	Topr	-20 to +75	°C
Storage Temperature Range	Tstg	-40 to +125	°C

\*(Note) EIA/JEDEC STANDARD Test board (76.2 x 114.3 x 1.6mm, 2-Layers, FR-4) mounting

**■ ELECTRICAL CHARACTERISTICS** (Ta=25°C, V<sup>+</sup>=9V, R<sub>L</sub>=47kΩ, Vin=100mVrms/1kHz  
MODE ; VOL=0dB, BAL=0dB, TS=By-Pass, AGC=OFF, BBE=OFF, Tone=0dB, eala=By-Pass)

PARAMETER	SYMBOL	TEST CONDITION	MIN.	TYP.	MAX.	UNIT
Operating Voltage	V <sup>+</sup>		8.0	9.0	10.0	V
Supply Current	I <sub>CC</sub>	No Signal	-	30	45	mA
Reference Voltage	V <sub>REF</sub>	No Signal	4.0	4.5	5.0	V
Maximum Input Voltage	V <sub>IM</sub>	VOL=-20dB, THD=10%	2.8	3.0	-	Vrms
Maximum Output Voltage	V <sub>OM</sub>	OUTPUT VOL=0dB, THD=1%	-	2.5	-	Vrms
Channel Balance	G <sub>CB</sub>	VOL=0dB	-1.5	0.0	1.5	dB
Balance Boost A	G <sub>BBA</sub>	CHS="0", BAL=Mute	-2.0	0.0	2.0	dB
Balance Cut A	G <sub>BCA</sub>	CHS="1", BAL=Mute Vin = 1Vrms	-	-	-70	dB
Balance Boost B	G <sub>BBB</sub>	CHS="1", BAL=Mute	-2.0	0.0	2.0	dB
Balance Cut B	G <sub>BCB</sub>	CHS="0", BAL=Mute Vin = 1Vrms	-	-	-70	dB
Total Harmonic Distortion	THD	Vo=0.5Vrms BW=400Hz to 30kHz	-	-	0.5	%
Maximum Voltage Gain	G <sub>VMAX</sub>	VOL= 0dB	-2.0	0.0	2.0	dB
Minimum Voltage Gain	G <sub>VMIN</sub>	VOL= Mute	-	-	-70	dB
Channel Separation	CS	Vin = 1Vrms	-	-	-70	dB
Output Noise 1	V <sub>NO1</sub>	VOL = 0dB BW=400Hz to 30kHz	-	-90 (31.6)	-85 (56.2)	dBV (μVrms)
Output Noise 2	V <sub>NO2</sub>	VOL = Mute BW = 400Hz to 30kHz	-	-106 (5.0)	-96 (15.8)	dBV (μVrms)

BW : Band Width

**◆TONE CONTROL CHARACTERISTICS** (Ta=25°C, V<sup>+</sup>=9V, R<sub>L</sub>=47kΩ, Vin=100mVrms/1kHz  
MODE ; VOL=0dB, BAL=0dB, TS=By-Pass, AGC=OFF, BBE=OFF, eala=By-Pass)

PARAMETER	SYMBOL	TEST CONDITION	MIN.	TYP.	MAX.	UNIT
Treble Boost Gain	G <sub>HFBST</sub>	TREB=+15dB, f=10kHz	12.5	15.0	17.5	dB
Treble Boost Flat	G <sub>HFFLT</sub>	TREB=0dB, f=10kHz	-2.0	0.0	2.0	dB
Treble Boost Cut	G <sub>HFCUT</sub>	TRBE=-15dB, f=10kHz	-17.5	-15.0	-12.5	dB
Bass Boost Gain	G <sub>LFBST</sub>	BASS=+15dB, f=100Hz	12.5	15.0	17.5	dB
Bass Boost Flat	G <sub>LFFLT</sub>	BASS=0dB, f=100Hz	-2.0	0.0	2.0	dB
Bass Boost Cut	G <sub>LF CUT</sub>	BASS=-15dB, f=100Hz	-17.5	-15.0	-12.5	dB

**◆AGC CHARACTERISTICS** (Ta=25°C, V<sup>+</sup>=9V, R<sub>L</sub>=47kΩ  
MODE ; VOL=0dB, BAL=0dB, TS=By-Pass, AGC=ON, BBE=OFF, Tone=0dB, eala=By-Pass)

PARAMETER	SYMBOL	TEST CONDITION	MIN.	TYP.	MAX.	UNIT
AGC Boost	G <sub>AGCBST</sub>	Vin=50mVrms, f=1kHz	1.5	3.5	5.5	dB
AGC Flat 1	G <sub>AGCFLT1</sub>	Vin=300mVrms, f=1kHz	-2.5	0.0	2.5	dB
AGC Flat 2	G <sub>AGCFLT2</sub>	Vin=400mVrms, f=1kHz	-2.5	0.0	2.5	dB
AGC Flat 3	G <sub>AGCFLT3</sub>	Vin=500mVrms, f=1kHz	-2.5	0.0	2.5	dB
AGC Flat 4	G <sub>AGCFLT4</sub>	Vin=600mVrms, f=1kHz	-2.5	0.0	2.5	dB
AGC Cut	G <sub>AGCCUT</sub>	Vin=2Vrms, f=1kHz	-14	-10	-6.0	dB

**◆BBE CHARACTERISTICS** (Ta=25°C, V<sup>+</sup>=9V, R<sub>L</sub>=47kΩ, Vin=100mVrms/1kHz  
MODE ; VOL=0dB, BAL=0dB, TS=By-Pass, AGC=OFF, Tone=0dB, eala=By-Pass)

PARAMETER	SYMBOL	TEST CONDITION	MIN.	TYP.	MAX.	UNIT
Low Boost Gain	G <sub>BBELOW</sub>	BBE-LOW =+15dB, f=50Hz	12.5	15	17.5	dB
High Boost Gain	G <sub>BBEHIGH</sub>	BBE-HIGH =+15dB, f=10kHz	12.5	15	17.5	dB

**◆eala CHARACTERISTICS** (Ta=25°C, V<sup>+</sup>=9V, R<sub>L</sub>=47kΩ, Vin=100mVrms/1kHz  
MODE ; VOL=0dB, BAL=0dB, TS=By-Pass, AGC=OFF, BBE=0dB, Tone=0dB)

PARAMETER	SYMBOL	TEST CONDITION	MIN.	TYP.	MAX.	UNIT
Simulated Stereo A	G <sub>SIMA</sub>	LIN+RIN→OUTa, f=1KHz, SIM	1.0	3.0	5.0	dB
Simulated Stereo B	G <sub>SIMB</sub>	LIN+RIN→OUTb, f=1KHz, SIM	1.0	3.0	5.0	dB
Surround 3D1	G <sub>3D1</sub>	LIN→OUTa, f=100Hz, SR2	5.5	7.5	9.5	dB
Surround 3D2	G <sub>3D2</sub>	LIN→OUTa, f=10KHz, SR2	-2.0	0.0	2.0	dB
Surround 3D3	G <sub>3D3</sub>	LIN→OUTb, f=100Hz, SR2	0.5	2.5	4.5	dB
Surround 3D4	G <sub>3D4</sub>	LIN→OUTa, f=100Hz, SR1	3.5	5.5	7.5	dB

**◆TruSurround CHARACTERISTICS** (Ta=25°C, V<sup>+</sup>=9V, R<sub>L</sub>=47kΩ, Vin=100mVrms/1kHz  
MODE; VOL=0dB, BAL=0dB, AGC=OFF, BBE=OFF, Tone=0dB, eala=By-Pass)

PARAMETER	SYMBOL	TEST CONDITION	MIN.	TYP.	MAX.	UNIT
Mix Down Gain	G <sub>TSMX</sub>	FLIN→LTS, f=1KHz Mix Down	-5	-3	-1	dB
By-Pass Gain	G <sub>TSBP</sub>	LIN→LTS, f=1KHz By-Pass	-2	0	2	dB
Tru Front Gain	G <sub>TSPF</sub>	FLIN→LTS, f=125Hz TS5.1ch	-0.5	1.5	3.5	dB
Tru Rear Gain 1	G <sub>TSR1</sub>	RLIN→LTS, f=125Hz TS5.1ch	1	3	5	dB
Tru Rear Gain 2	G <sub>TSR2</sub>	RLIN→LTS, f=125Hz TS4ch	2	4	6	dB
Center Gain	G <sub>TSC</sub>	CIN→LTS, f=1KHz TS4ch	-5	-3	-1	dB
Sub Woofer Gain	G <sub>TSS</sub>	SWIN→LTS, f=1KHz TS4ch	-2	0	2	dB
Feed Through Gain	G <sub>THROUGH</sub>	LIN→LTS, f=1KHz SRS 3D,Space=Min, Center=Min	-20	-18	-16	dB
L+R Gain	G <sub>L+R</sub>	LIN→RTS, f=1KHz SRS 3D,Space=Min, Center=Max	-15	-13	-11	dB
L-R Gain	G <sub>L-R</sub>	LIN→LTS, f=125Hz SRS 3D,Space=Max, Center=Min	-2	0	2	dB
Passive Gain 1	G <sub>TSP1</sub>	LIN→LTS, f=125Hz TS2ch, Space=Max, Center=Max	4.0	6.0	8.0	dB
Passive Gain 2	G <sub>TSP2</sub>	LIN→RTS, f=125Hz TS2ch, Space=Max, Center=Max	-5.5	-3.5	-1.5	dB

## ■ I<sup>2</sup>C BUS CHARACTERISTICS (SDA, SCL)

I<sup>2</sup>C BUS Load Conditions: Pull up resistance 4kΩ (Connected to +5V), Load capacitance 200pF (Connected to GND)

PARAMETER	SYMBOL	MIN.	TYP.	MAX.	UNIT
High Level Input Voltage	V <sub>IH</sub>	3.0	-	5.0	V
Low Level Input Voltage	V <sub>IL</sub>	0	-	1.5	V
High Level Input Current	I <sub>IH</sub>	-	-	10	μA
Low Level Input Current	I <sub>IL</sub>	-	-	10	μA
Low Level Output Voltage (3mA at SDA pin)	V <sub>OL</sub>	0	-	0.4	V
Maximum Output Current	I <sub>OL</sub>	-3.0	-	-	mA
Maximum Clock Frequency	f <sub>SCL</sub>	-	-	100	kHz
Data Change Minimum Waiting Time	t <sub>BUF</sub>	4.7	-	-	μs
Data Transfer Start Minimum Waiting Time	t <sub>HD:STA</sub>	4.0	-	-	μs
Low Level Clock Pulse Width	t <sub>LOW</sub>	4.7	-	-	μs
High Level Clock Pulse Width	t <sub>HIGH</sub>	4.0	-	-	μs
Minimum Start Preparation Waiting Time	t <sub>SU:STA</sub>	4.7	-	-	μs
Minimum Data Hold Time	t <sub>HD:DAT</sub>	0	-	3.45	μs
Minimum Data Preparation Time	t <sub>SU:DAT</sub>	250	-	-	ns
Rise Time	t <sub>R</sub>	-	-	1.0	μs
Fall Time	t <sub>F</sub>	-	-	300	ns
Minimum Stop Preparation Waiting Time	t <sub>SU:STO</sub>	4.0	-	-	μs

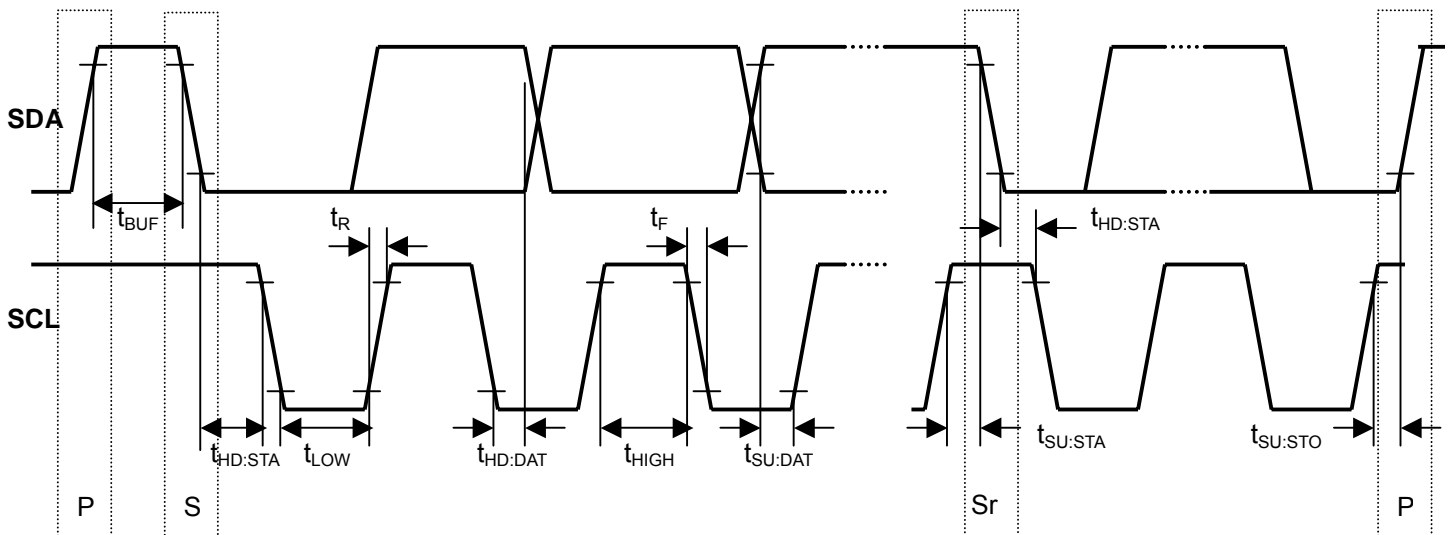

# NJW1149A

## APPLICATION CIRCUIT 1 (Bi-Amp outputs)

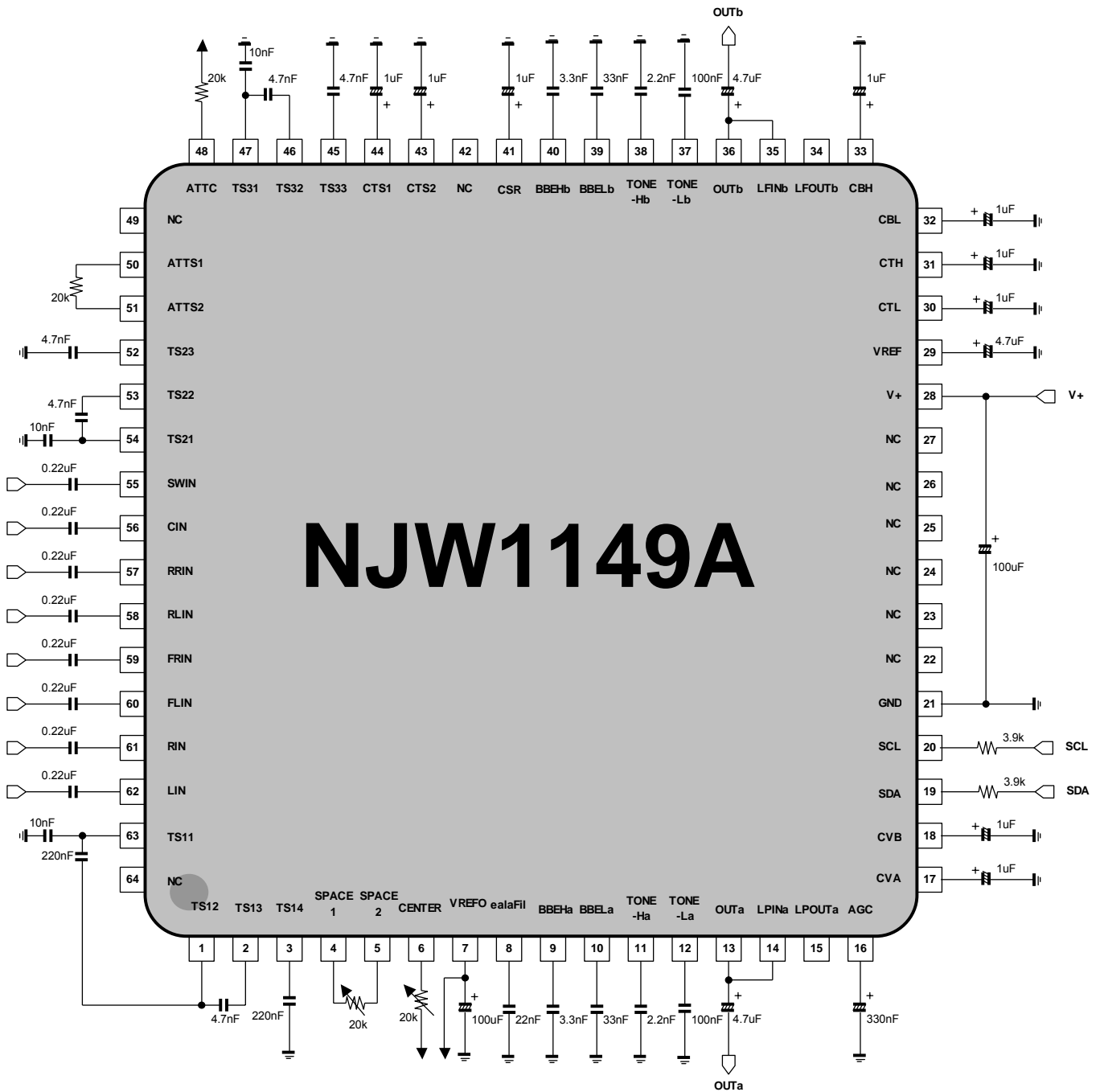

# NJW1149A

**(NOTE)**

1. Separate the I<sup>2</sup>C bus line from the following terminals for avoiding digital noise problem.

Pin No.	Symbol	Pin No.	Symbol	Pin No.	Symbol	Pin No.	Symbol	Pin No.	Symbol
1	TS12	9	BBE1a	37	TONE-Lb	45	TS33	53	TS22
2	TS13	10	BBE2a	38	TONE-Hb	46	TS32	54	TS21
3	TS14	11	TONE-Ha	39	BBE2b	47	TS31	63	TS11
8	eala Fil	12	TONE-La	40	BBE1b	52	TS23	-	-

2. The constant of capacitors connected to the terminals No.9, 10, 39 and 40 are designated by BBE Sound Inc.

3. The constant of capacitors connected to the terminals No.1,2,3,45,46,47,52,53,54,55 and 63 are designated by SRS Labs, Inc.

## < Output Type >

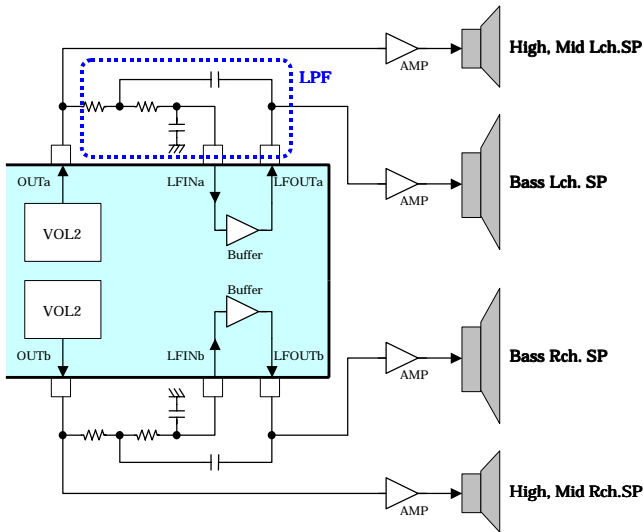

Fig 1. Bi-Amp

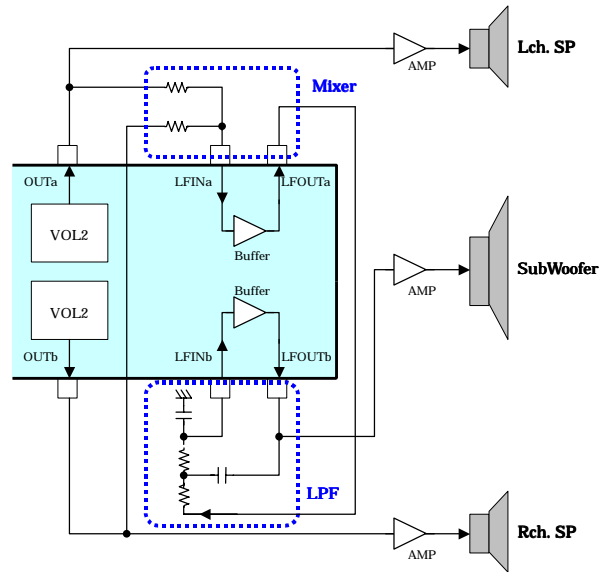
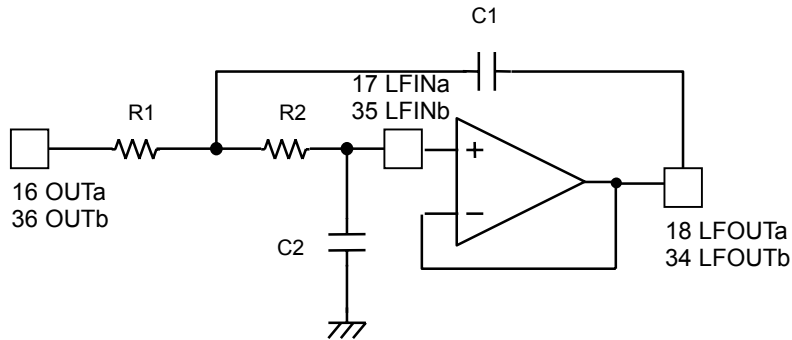

Fig 2. Sub-Woofers

## < OUT, LFIN, LFOUT Low Pass Filter Setting >

LPF cut off frequency and quality factor are adjusted by the external parts and given by the following functions.



$$f_c = \frac{1}{2\pi\sqrt{R1 \cdot R2 \cdot C1 \cdot C2}} \text{ (Hz)}$$

$$Q = \frac{1}{\sqrt{\frac{C2 \cdot R1}{C1 \cdot R2}} + \sqrt{\frac{C1 \cdot R2}{C2 \cdot R1}}}$$

## ■ TERMINAL DESCRIPTION

PIN NO.	SYMBOL	FUNCTION	EQUIVALENT CIRCUIT	TERMINAL VOLTAGE
1 2 3	TS12 TS13 TS14	TruSurround Filter Capacitor 12 TruSurround Filter Capacitor 13 TruSurround Filter Capacitor 14		V+/2
4 51	SPACE1 ATTS1	SPACE Volume1 Surround Attenuation Resistor 1		V+/2
5 7 50	SPACE2 VREFO ATTS2	SPACE Volume2 Reference Voltage Output Capacitor Surround Attenuation Resistor 2		V+/2
6 8 14 35 48 55 56 57 58 59 60 61 62	CENTER ealaFil LFINa LFINb ATTC SWIN CIN RRIN RLIN FRIN FLIN RIN LIN	CENTER Volume eala Filter Capacitor Buffer Input for Ach Low Pass Filter Buffer Input for Bch Low Pass Filter Center Attenuation Resistor SW ch Input C ch Input Rear-R ch Input Rear-L ch Input Front-R ch Input Front-L ch Input R ch Input L ch Input		V+/2



PIN NO.	SYMBOL	FUNCTION	EQUIVALENT CIRCUIT	TERMINAL VOLTAGE
22	N.C.	No Connection		
23	N.C.	No Connection		
24	N.C.	No Connection		
25	N.C.	No Connection		
26	N.C.	No Connection		
27	N.C.	No Connection		
42	N.C.	No Connection	-	-
49	N.C.	No Connection		
64	N.C.	No Connection		
16 18 34 36	OUTa LFOUTa LFOUTb OUTb	Ach Output Buffer Output for Ach Low Pass Filter Buffer Output for Bch Low Pass Filter Bch Output		V+/2
9 10 39 40	BBE1a BBE2a BBE2b BBE1b	Ach BBE High-Pass Filter Capacitor Ach BBE Low-Pass Filter Capacitor Bch BBE Low-Pass Filter Capacitor Bch BBE High-Pass Filter Capacitor		V+/2
11 38	TONE-Ha TONE-Hb	Ach TONE Treble Filter Capacitor Bch TONE Treble Filter Capacitor		V+/2

# NJW1149A

www.DataSheet4U.com

PIN NO.	SYMBOL	FUNCTION	EQUIVALENT CIRCUIT	TERMINAL VOLTAGE
12 37	TONE-La TONE-Lb	Ach TONE Bass Filter Capacitor Bch TONE Bass Filter Capacitor		V+/2
19	AGC	AGC Smoothing Filter Capacitor		-
17 18	CVA CVB	Ach Volume switching noise rejection Capacitor Bch Volume switching noise rejection Capacitor		VREF-0.7V
19 20	SDA SCL	I <sup>2</sup> C Data Input I <sup>2</sup> C Clock Input		-

PIN NO.	SYMBOL	FUNCTION	EQUIVALENT CIRCUIT	TERMINAL VOLTAGE
21	GND	Ground	-	-
28	V+	Power Supply	-	V+
29	VREF	Reference Voltage Capacitor	<p>The diagram shows a voltage divider circuit connected to the VREF pin. It consists of two 200k resistors connected in series between the VREF pin and ground. The midpoint of this divider is connected to the non-inverting input of a differential amplifier. The differential amplifier is also connected to ground through a capacitor, representing the reference voltage capacitor.</p>	V+/2
30	CTL	Tone Control Bass switching noise rejection Capacitor	<p>The diagram shows a differential amplifier stage. The CTL pin is connected to the non-inverting input of the amplifier. The CTH pin is connected to the inverting input. A 36k resistor is connected between the CTL and CTH pins. The amplifier is also connected to ground through a capacitor, representing the tone control treble switching noise rejection capacitor.</p>	VREF-0.7V
31	CTH	Tone Control Treble switching noise rejection Capacitor		

# NJW1149A

www.DataSheet4U.com

PIN NO.	SYMBOL	FUNCTION	EQUIVALENT CIRCUIT	TERMINAL VOLTAGE
32	CBL	BBE Low switching noise rejection Capacitor		VREF-0.7V
33	CBH	BBE High switching noise rejection Capacitor		
41	CSR	eala switching noise rejection Capacitor		0.54V(CSR) 1.4V(CTS2)
43	CTS2	TruSurround switching noise rejection Capacitor 2		
44	CTS1	TruSurround switching noise rejection Capacitor 1		-
45	TS33	TruSurround Filter Capacitor 33		V+/2
46	TS32	TruSurround Filter Capacitor 32		
47	TS31	TruSurround Filter Capacitor 31		
52	TS23	TruSurround Filter Capacitor 23		
53	TS22	TruSurround Filter Capacitor 22		
54	TS21	TruSurround Filter Capacitor 21		

PIN NO.	SYMBOL	FUNCTION	EQUIVALENT CIRCUIT	TERMINAL VOLTAGE
63	TS11	TruSurround Filter Capacitor 11		V+/2

## ■ DEFINITION OF I<sup>2</sup>C REGISTER

### ● I<sup>2</sup>C BUS FORMAT

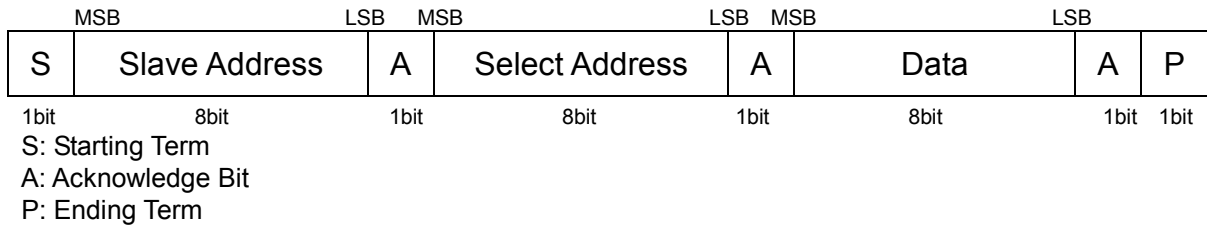

### ● SLAVE ADDRESS



### ● CONTROL REGISTER TABLE

The select address sets each function (Volume, Balance, AGC, Surround, BBE, Tone Control).  
The auto-increment function cycles the select address as follows.  
00H→01H→02H→03H→04H→05H→06H→00H

Select Address	BIT							
	D7	D6	D5	D4	D3	D2	D1	D0
00H	VOL							
01H	CHS	BAL					Don't Care	
02H	BCB	BASS					Don't Care	
03H	BCT	TREB					Don't Care	
04H	BBEL					BBE	Don't Care	
05H	BBEH					AGC	AGC LVL	
06H	eala		TS MODE				Don't Care	

### ● CONTROL REGISTER DEFAULT VALUE

Control register default value is all "0".

Select Address	BIT							
	D7	D6	D5	D4	D3	D2	D1	D0
00H	0	0	0	0	0	0	0	0
01H	0	0	0	0	0	0	0	0
02H	0	0	0	0	0	0	0	0
03H	0	0	0	0	0	0	0	0
04H	0	0	0	0	0	0	0	0
05H	0	0	0	0	0	0	0	0
06H	0	0	0	0	0	0	0	0

## ● CONTROL COMMAND TABLE

### a) Master Volume

Select Address	BIT							
	D7	D6	D5	D4	D3	D2	D1	D0
00H	VOL							

●VOL : Master Volume

Attenuation level : 0 to -80dB(0.33dB/step), MUTE

The volume is consisted of VOL1 and VOL2 and the level is divided into half to each VOL1 and VOL2.

ex) Volume setting is -2dB ; VOL1 and VOL2 is set -1dB each.

### b) Balance

Select Address	BIT							
	D7	D6	D5	D4	D3	D2	D1	D0
01H	CHS	BAL					Don't Care	

●CHS : Balance channel select

“0” : Ach “Bch is attenuated”

“1” : Bch “Ach is attenuated”

●BAL : Ach and Bch Balance

Balance Level : 0 to -30dB (1dB/Step) , MUTE

### c) Tone Control BASS

Select Address	BIT							
	D7	D6	D5	D4	D3	D2	D1	D0
03H	BCB	BASS					Don't Care	

●BCB : Bass Boost or Cut

“0” : Cut

“1” : Boost

●BASS : BASS Level

Cut Level : -15 to 0dB(0.5dB/Step)

Boost Level : 0 to +15dB(0.5dB/Step)

### e) Tone Control TREBLE

Select Address	BIT							
	D7	D6	D5	D4	D3	D2	D1	D0
04H	BCT	TREB					Don't Care	

●BCT : Treble Boost or Cut

“0” : Cut

“1” : Boost

●TREB : Treble Level

Cut Level : -15 to 0dB(0.5dB/Step)

Boost Level : 0 to +15dB(0.5dB/Step)

### f) BBE-Low

Select Address	BIT							
	D7	D6	D5	D4	D3	D2	D1	D0
05H	BBEL					BBE	Don't Care	

● BBEL:BBE-LOW Level

0dB to 15dB (0.5dB/step)

●BBE : BBE ON or OFF

## g) BBE-High

Select Address	BIT							
	D7	D6	D5	D4	D3	D2	D1	D0
05H	BBEH					AGC	AGC LVL	

•**BBEH: BBE-HIGH Level**

0dB to 15dB (0.5dB/step)

•**AGC : AGC ON or OFF**

•**AGC LVL : AGC Level**

300mVrms, 400mVrms, 500mVrms, 600mVrms

## h) Surround (eala, TruSurround)

Select Address	BIT							
	D7	D6	D5	D4	D3	D2	D1	D0
06H	eala		TS MODE				Don't Care	

•**eala : eala mode**

Surround effect small (SR1), large (SR2), Simulated Stereo (SIM), By-Pass

•**TS MODE : TruSurround mode**

By-Pass, SRS 3D, TS2ch (Passive Matrix TruSurround), TS4ch (for Dolby Pro Logic), TS5.1ch (for Dolby Digital), Mix Down



■ Master Volume (Select Address: 00H)

		VOL							
Gain(dB)	HEX	D7	D6	D5	D4	D3	D2	D1	D0
0	FF	1	1	1	1	1	1	1	1
-1	FC	1	1	1	1	1	1	0	0
-2	F9	1	1	1	1	1	0	0	1
-3	F6	1	1	1	1	0	1	1	0
-4	F3	1	1	1	1	0	0	1	1
-5	F0	1	1	1	1	0	0	0	0
-6	ED	1	1	1	0	1	1	0	1
-7	EA	1	1	1	0	1	0	1	0
-8	E7	1	1	1	0	0	1	1	1
-9	E4	1	1	1	0	0	1	0	0
-10	E1	1	1	1	0	0	0	0	1
-11	DE	1	1	0	1	1	1	1	0
-12	DB	1	1	0	1	1	0	1	1
-13	D8	1	1	0	1	1	0	0	0
-14	D5	1	1	0	1	0	1	0	1
-15	D2	1	1	0	1	0	0	1	0
-16	CF	1	1	0	0	1	1	1	1
-17	CC	1	1	0	0	1	1	0	0
-18	C9	1	1	0	0	1	0	0	1
-19	C6	1	1	0	0	0	1	1	0
-20	C3	1	1	0	0	0	0	1	1
-21	C0	1	1	0	0	0	0	0	0
-22	BD	1	0	1	1	1	1	0	1
-23	BA	1	0	1	1	1	0	1	0
-24	B7	1	0	1	1	0	1	1	1
-25	B4	1	0	1	1	0	1	0	0
-26	B1	1	0	1	1	0	0	0	1
-27	AE	1	0	1	0	1	1	1	0
-28	AB	1	0	1	0	1	0	1	1
-29	A8	1	0	1	0	1	0	0	0
-30	A5	1	0	1	0	0	1	0	1
-31	A2	1	0	1	0	0	0	1	0
-32	9F	1	0	0	1	1	1	1	1
-33	9C	1	0	0	1	1	1	0	0
-34	99	1	0	0	1	1	0	0	1
-35	96	1	0	0	1	0	1	1	0
-36	93	1	0	0	1	0	0	1	1
-37	90	1	0	0	1	0	0	0	0
-38	8D	1	0	0	0	1	1	0	1
-39	8A	1	0	0	0	1	0	1	0
-40	87	1	0	0	0	0	1	1	1
-41	84	1	0	0	0	0	1	0	0
-42	81	1	0	0	0	0	0	0	1

# NJW1149A

www.DataSheet4U.com

		VOL							
Gain(dB)	HEX	D7	D6	D5	D4	D3	D2	D1	D0
-43	7E	0	1	1	1	1	1	1	0
-44	7B	0	1	1	1	1	0	1	1
-45	78	0	1	1	1	1	0	0	0
-46	75	0	1	1	1	0	1	0	1
-47	72	0	1	1	1	0	0	1	0
-48	6F	0	1	1	0	1	1	1	1
-49	6C	0	1	1	0	1	1	0	0
-50	69	0	1	1	0	1	0	0	1
-51	66	0	1	1	0	0	1	1	0
-52	63	0	1	1	0	0	0	1	1
-53	60	0	1	1	0	0	0	0	0
-54	5D	0	1	0	1	1	1	0	1
-55	5A	0	1	0	1	1	0	1	0
-56	57	0	1	0	1	0	1	1	1
-57	54	0	1	0	1	0	1	0	0
-58	51	0	1	0	1	0	0	0	1
-59	4E	0	1	0	0	1	1	1	0
-60	4B	0	1	0	0	1	0	1	1
-61	48	0	1	0	0	1	0	0	0
-62	45	0	1	0	0	0	1	0	1
-63	42	0	1	0	0	0	0	1	0
-64	3F	0	0	1	1	1	1	1	1
-65	3C	0	0	1	1	1	1	0	0
-66	39	0	0	1	1	1	0	0	1
-67	36	0	0	1	1	0	1	1	0
-68	33	0	0	1	1	0	0	1	1
-69	30	0	0	1	1	0	0	0	0
-70	2D	0	0	1	0	1	1	0	1
-71	2A	0	0	1	0	1	0	1	0
-72	27	0	0	1	0	0	1	1	1
-73	24	0	0	1	0	0	1	0	0
-74	21	0	0	1	0	0	0	0	1
-75	1E	0	0	0	1	1	1	1	0
-76	1B	0	0	0	1	1	0	1	1
-77	18	0	0	0	1	1	0	0	0
-78	15	0	0	0	1	0	1	0	1
-79	12	0	0	0	1	0	0	1	0
-80	0F	0	0	0	0	1	1	1	1
Mute	00	0	0	0	0	0	0	0	0

■ Balance (Select Address: 01H)

Channel Setting (CHS)	D7
Attenuated Bch Gain	0
Attenuated Ach Gain	1

Gain(dB)	BAL				
	D6	D5	D4	D3	D2
0	0	0	0	0	0
-1	0	0	0	0	1
-2	0	0	0	1	0
-3	0	0	0	1	1
-4	0	0	1	0	0
-5	0	0	1	0	1
-6	0	0	1	1	0
-7	0	0	1	1	1
-8	0	1	0	0	0
-9	0	1	0	0	1
-10	0	1	0	1	0
-11	0	1	0	1	1
-12	0	1	1	0	0
-13	0	1	1	0	1
-14	0	1	1	1	0
-15	0	1	1	1	1
-16	1	0	0	0	0
-17	1	0	0	0	1
-18	1	0	0	1	0
-19	1	0	0	1	1
-20	1	0	1	0	0
-21	1	0	1	0	1
-22	1	0	1	1	0
-23	1	0	1	1	1
-24	1	1	0	0	0
-25	1	1	0	0	1
-26	1	1	0	1	0
-27	1	1	0	1	1
-28	1	1	1	0	0
-29	1	1	1	0	1
-30	1	1	1	1	0
MUTE	1	1	1	1	1

# NJW1149A

www.DataSheet4U.com

## ■ Tone Control Bass (Select Address: 02H)

Bass Cut or Boost	BCB
	D7
Cut	0
Boost	1

		BASS				
Cut Gain(dB)	Boost Gain(dB)	D6	D5	D4	D3	D2
-15	15	1	1	1	1	0
-14	14	1	1	1	0	0
-13	13	1	1	0	1	0
-12	12	1	1	0	0	0
-11	11	1	0	1	1	0
-10	10	1	0	1	0	0
-9	9	1	0	0	1	0
-8	8	1	0	0	0	0
-7	7	0	1	1	1	0
-6	6	0	1	1	0	0
-5	5	0	1	0	1	0
-4	4	0	1	0	0	0
-3	3	0	0	1	1	0
-2	2	0	0	1	0	0
-1	1	0	0	0	1	0
0	0	0	0	0	0	0

## ■ Tone Control Treble (Select Address: 03H)

Treble Cut or Boost	BCT
	D7
Cut	0
Boost	1

		TREB				
Cut Gain(dB)	Boost Gain(dB)	D6	D5	D4	D3	D2
-15	15	1	1	1	1	0
-14	14	1	1	1	0	0
-13	13	1	1	0	1	0
-12	12	1	1	0	0	0
-11	11	1	0	1	1	0
-10	10	1	0	1	0	0
-9	9	1	0	0	1	0
-8	8	1	0	0	0	0
-7	7	0	1	1	1	0
-6	6	0	1	1	0	0
-5	5	0	1	0	1	0
-4	4	0	1	0	0	0
-3	3	0	0	1	1	0
-2	2	0	0	1	0	0
-1	1	0	0	0	1	0
0	0	0	0	0	0	0

■ BBE-LOW Gain Code (Select Address: 04H)

Gain(dB)	BBEL				
	D7	D6	D5	D4	D3
15	1	1	1	1	0
14	1	1	1	0	0
13	1	1	0	1	0
12	1	1	0	0	0
11	1	0	1	1	0
10	1	0	1	0	0
9	1	0	0	1	0
8	1	0	0	0	0
7	0	1	1	1	0
6	0	1	1	0	0
5	0	1	0	1	0
4	0	1	0	0	0
3	0	0	1	1	0
2	0	0	1	0	0
1	0	0	0	1	0
0	0	0	0	0	0

■ BBE (Select Address: 04H)

BBE ON/OFF	BBE
	D2
OFF	0
ON	1

■ BBE-HIGH Gain Code (Select Address: 05H)

Gain(dB)	BBEH				
	D7	D6	D5	D4	D3
15	1	1	1	1	0
14	1	1	1	0	0
13	1	1	0	1	0
12	1	1	0	0	0
11	1	0	1	1	0
10	1	0	1	0	0
9	1	0	0	1	0
8	1	0	0	0	0
7	0	1	1	1	0
6	0	1	1	0	0
5	0	1	0	1	0
4	0	1	0	0	0
3	0	0	1	1	0
2	0	0	1	0	0
1	0	0	0	1	0
0	0	0	0	0	0

# NJW1149A

www.DataSheet4U.com

## ■ AGC (Select Address: 05H)

AGC ON/OFF	AGC
	D2
OFF	0
ON	1

## ■ AGC Level (Select Address: 05H)

AGC Level	AGC LVL	
	D1	D0
300mVrms	0	0
400mVrms	0	1
500mVrms	1	0
600mVrms	1	1

## ■ eala mode (Select Address: 06H)

eala MODE	eala	
	D7	D6
By-Pass	0	0
Simulated Stereo (SIM)	0	1
3D Effect Large (SR2)	1	0
3D Effect Small (SR1)	1	1

## ■ TruSurround mode(Select Address: 06H)

TruSurround MODE	TS MODE			
	D5	D4	D3	D2
By-Pass	0	0	0	0
SRS 3D	0	0	1	1
TS2ch	0	1	0	1
TS4ch	1	0	0	0
TS5.1ch	1	1	0	0
Mix Down	1	1	1	0

## NOTE

The **NJW1149A** is manufactured by New Japan Radio Co., Ltd. under license from BBE Sound Inc. BBE is a registered trademark of BBE Sound Inc. A license from BBE Sound Inc. is required before the **NJW1149A** can be purchased from New Japan Radio Co.,Ltd.

BBE Sound, Inc.  
5381 Production Drive  
Huntington Beach, CA 92649  
Tel:(714) 897-6766  
Fax:(714) 896-0736

The TruSurround technology right incorporated in the **NJW1149A** are owned by SRS Labs, a U.S. Corporation and licensed to New Japan Radio Co., Ltd. Purchaser of **NJW1149A** must sign a license for use of the chip and display of the SRS Labs trademarks. Any products incorporating the **NJW1149A** must be sent to SRS Labs for review. TruSurround is protected under U.S. and foreign patents issued and/or pending. TruSurround, SRS and the  symbol are trademarks of SRS Labs, Inc. in the United States and selected foreign countries. Neither the purchase of the **NJW1149A**, nor the corresponding sale of audio enhancement equipment conveys the right to sell commercialized recordings made with any SRS technology.

SRS Labs requires all set makers to comply with all rules and regulations as outlined in the SRS Trademark Usage Manual separately provided.

For further information, please contact:

SRS Labs, Inc.  
2909 Daimler Street. Santa Ana, CA 92705 USA

Tel: 949-442-1070 Fax: 949-852-1099 <http://www.srslabs.com>

### [CAUTION]

The specifications on this data book are only given for information, without any guarantee as regards either mistakes or omissions. The application circuits in this data book are described only to show representative usages of the product and not intended for the guarantee or permission of any right including the industrial rights.