



Audio Processor with SRS WOW

■ GENERAL DESCRIPTION

The **NJW1183** is an audio processor with SRS WOW. It includes all of functions processing audio signal for TV, such as volume, balance and tone control. All of internal status and variables are controlled by I²C BUS.

■ PACKAGE OUTLINE

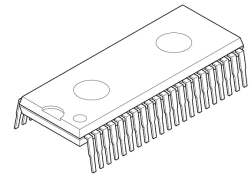

NJW1183L

■ FEATURES

- Operating Voltage 8 to 13 V
- SRS WOW (including SRS 3D, FOCUS and TruBass function)
- Simulated Stereo
- 4ch Input Selector
- Volume 0 to -80dB (0.5dB/step), MUTE
- Balance 0 to -30dB (1dB/step), MUTE
- Tone Control -9dB to +9dB(1dB/step)
- I²C BUS Interface
- Bi-CMOS Technology
- Package Outline SDIP42

■ BLOCK DIAGRAM

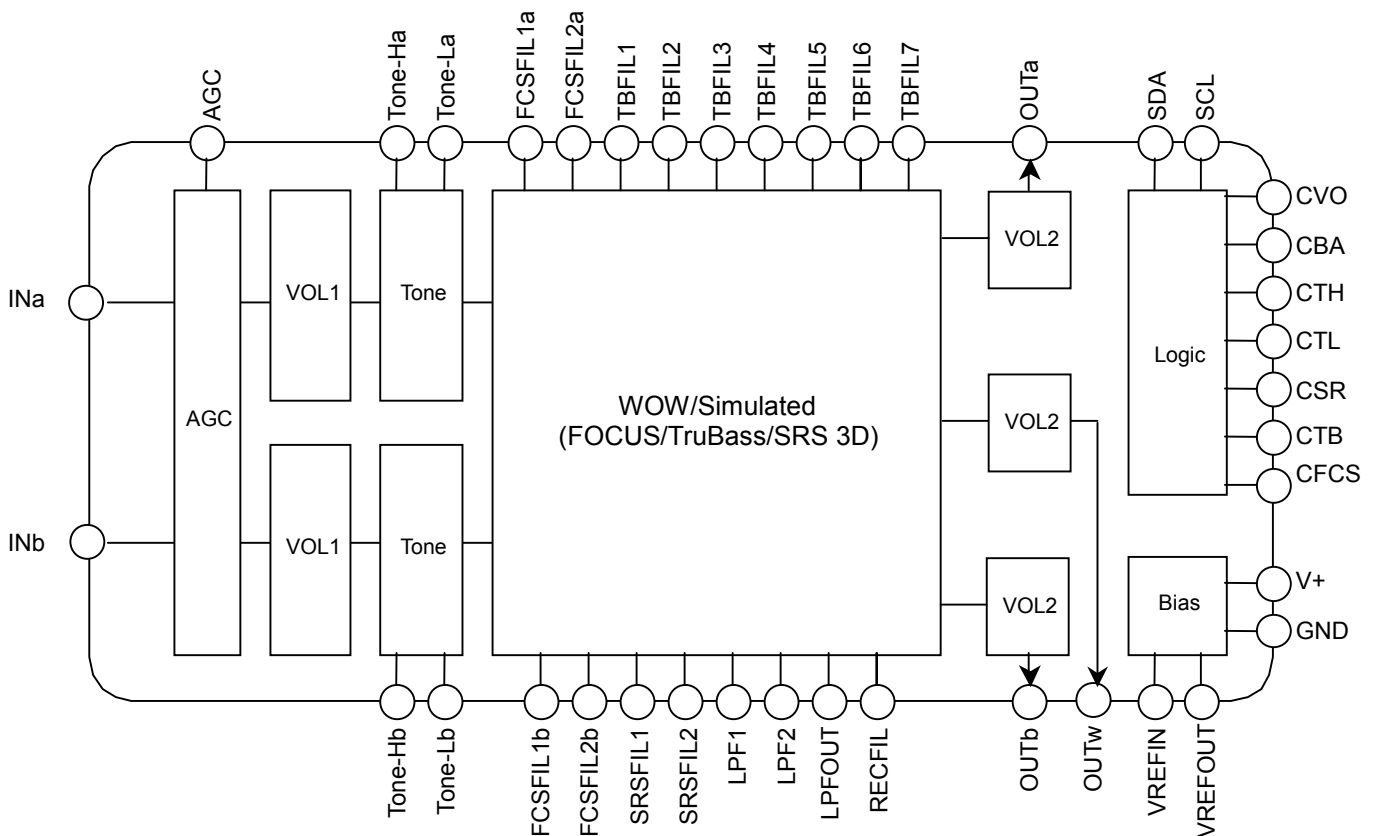

■ PIN FUNCTION (SDIP42)

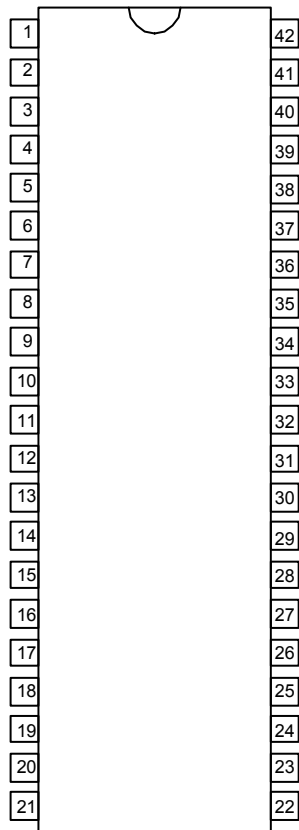

- | | | |
|--------------|-------------|--------------|
| 1. TBFIL2 | 15. TONE-La | 29. TONE-Hb |
| 2. TBFIL1 | 16. OUTa | 30. TESTb |
| 3. LPFOUT | 17. CTH | 31. INb |
| 4. LPF2 | 18. CTL | 32. AGC |
| 5. LPF1 | 19. SDA | 33. FCSFIL2b |
| 6. OUTW | 20. SCL | 34. FCSFIL1b |
| 7. SRSFIL1 | 21. GND | 35. CTB |
| 8. CSR | 22. V+ | 36. SRSFIL2 |
| 9. FCSFIL1a | 23. VREFOUT | 37. RECFIL |
| 10. FCSFIL2a | 24. VREFIN | 38. TBFIL7 |
| 11. CFCS | 25. CVO | 39. TBFIL6 |
| 12. INa | 26. CBA | 40. TBFIL5 |
| 13. TESTa | 27. OUTb | 41. TBFIL4 |
| 14. TONE-Ha | 28. TONE-Lb | 42. TBFIL3 |

■ ABSOLUTE MAXIMUM RATING (Ta=25°C)

PARAMETER	SYMBOL	RATING	UNIT
Supply Voltage	V ⁺	15	V
Power Dissipation	P _D	700	mW
Operating Temperature Range	Topr	-40 to +85	°C
Storage Temperature Range	Tstg	-40 to +125	°C

■ ELECTRICAL CHARACTERISTICS

(Ta=25°C, V+=9V, Rg=600Ω, RL=47kΩ, Vin=100mVrms/1kHz unless otherwise specified)

PARAMETER	SYMBOL	TEST CONDITION	MIN.	TYP.	MAX.	UNIT
Operating Voltage	V ⁺		8.0	9.0	13.0	V
Supply Current	I _{CC}	No Signal	-	20	35	mA
Reference Voltage	V _{REF}	No Signal	4.0	4.5	5.0	V
Maximum Input Voltage	V _{IM}	VOL=-20dB, THD=10%	2.8	3.0	-	Vrms
Maximum Output Voltage	V _{OM}	OUTPUT VOL=0dB, THD=1%	-	2.5	-	Vrms
Maximum Gain	G _{VMAX}	VOL= 0dB	-2.0	0.0	2.0	dB
Minimum Gain	G _{VMIN}	VOL= MUTE, Vin=2Vrms	-	-100	-90	dB
Channel Balance 1	G _{CB1}	VOL=0dB	-1.0	0.0	1.0	dB
Channel Balance 2	G _{CB2}	VOL=-70dB, Vin=1Vrms	-1.0	0.0	1.0	dB
Balance Boost A	BA _{BST}	CHS="0", BAL="11111"	-2.0	0.0	2.0	dB
Balance Cut A	BA _{CUT}	CHS="1", BAL="11111" Vin = 1Vrms	-	-	-70	dB
Balance Boost B	BB _{BST}	CHS="1", BAL="11111"	-2.0	0.0	2.0	dB
Balance Cut B	BB _{CUT}	CHS="0", BAL="11111" Vin = 1Vrms	-	-	-70	dB
Total Harmonic Distortion	THD	Vo=0.5Vrms BW=400Hz to 30kHz	-	-	0.5	%
Channel Separation	CS	Vin = 1Vrms A-weighting	-	-80	-70	dB
Output Noise 1	V _{NO1}	VOL = 0dB A-weighting	-	-90 (31.6)	-85 (56.2)	dBV (μVrms)
Output Noise 2	V _{NO2}	VOL = MUTE A-weighting	-	-106 (5.0)	-96 (15.8)	dBV (μVrms)

◆ TONE CONTROL

PARAMETER	SYMBOL	TEST CONDITION	MIN.	TYP.	MAX.	UNIT
High Frequency Boost	HF _{BST}	BCT="1", TREB="1001", f=10kHz	6.5	9.0	11.5	dB
High Frequency Flat	HF _{FLT}	TREB="0000", f=10kHz	-2.0	0.0	2.0	dB
High Frequency Cut	HF _{CUT}	BCT="0", TREB="1001", f=10kHz	-11.5	-9.0	-6.5	dB
Low Frequency Boost	LF _{BST}	BCB="1", BASS="1001", f=100Hz	6.5	9.0	11.5	dB
Low Frequency Flat	LF _{FLT}	BASS="0000", f=100Hz	-2.0	0.0	2.0	dB
Low Frequency Cut	LF _{CUT}	BCB="0", BASS="1001", f=100Hz	-11.5	-9.0	-6.5	dB

◆ AGC CONTROL

PARAMETER	SYMBOL	TEST CONDITION	MIN.	TYP.	MAX.	UNIT
AGC Boost	AGC _{BST}	AGC-FLAT = "300mVrms", Vin=50mVrms, f=1kHz	1.5	3.5	5.5	dB
AGC Flat1	AGC _{FLT1}	AGC-FLAT = "300mVrms", Vin=300mVrms, f=1kHz	-2.5	0.0	2.5	dB
AGC Flat2	AGC _{FLT2}	AGC-FLAT = "400mVrms", Vin=400mVrms, f=1kHz	-2.5	0.0	2.5	dB
AGC Flat3	AGC _{FLT3}	AGC-FLAT = "500mVrms", Vin=500mVrms, f=1kHz	-2.5	0.0	2.5	dB
AGC Flat4	AGC _{FLT4}	AGC-FLAT = "600mVrms", Vin=600mVrms, f=1kHz	-2.5	0.0	2.5	dB
AGC Cut	AGC _{CUT}	AGC-FLAT = "300mVrms", Vin=2Vrms, f=1kHz	-14	-10	-6.0	dB

◆ SURROUND

PARAMETER	SYMBOL	TEST CONDITION	MIN.	TYP.	MAX.	UNIT
FOCUS Gain1	G _{FCS1}	FCS="001", f=10kHz, Ain → Aout	2.0	4.0	6.0	dB
FOCUS Gain2	G _{FCS2}	FCS="010", f=10kHz, Ain → Aout	3.0	5.0	7.0	dB
FOCUS Gain3	G _{FCS3}	FCS="011", f=10kHz, Ain → Aout	4.0	6.0	8.0	dB
FOCUS Gain4	G _{FCS4}	FCS="100", f=10kHz, Ain → Aout	5.0	7.0	9.0	dB
TruBass Gain1	G _{TB1}	TB="001", f=100Hz, Ain+Bin → Aout	4.0	6.0	8.0	dB
TruBass Gain2	G _{TB2}	TB="010", f=100Hz, Ain+Bin → Aout	5.0	7.0	9.0	dB
TruBass Gain3	G _{TB3}	TB="011", f=100Hz, Ain+Bin → Aout	6.0	8.0	10.0	dB
TruBass Gain4	G _{TB4}	TB="100", f=100Hz, Ain+Bin → Aout	7.0	9.0	11.0	dB
Simulated Stereo Gain	G _{SIM1}	SUR="001", f=1kHz, Ain+Bin → Aout	1.0	3.0	5.0	dB
SRS Gain1	G _{SRS1}	SUR="010", f=125Hz, Ain → Aout	4.0	6.0	8.0	dB
SRS Gain2	G _{SRS2}	SUR="011", f=125Hz, Ain → Aout	5.0	7.0	9.0	dB
SRS Gain3	G _{SRS3}	SUR="100", f=125Hz, Ain → Aout	6.0	8.0	10.0	dB
SRS Gain4	G _{SRS4}	SUR="101", f=125Hz, Ain → Aout	7.0	9.0	11.0	dB

■ I²C BUS CHARACTERISTICS (SDA, SCL)

I²C BUS Load Conditions: Pull up resistance 4kΩ (Connected to +5V), Load capacitance 200pF (Connected to GND)

PARAMETER	SYMBOL	STANDARD MODE			FAST MODE			UNIT
		MIN.	TYP.	MAX.	MIN.	TYP.	MAX.	
Low Level Input Voltage	V _{IL}	0.0	-	1.5	0.0	-	1.5	V
High Level Input Voltage	V _{IH}	2.7	-	5.0	2.7	-	5.0	V
Hysteresis of Schmitt trigger inputs	V _{hys}	-	-	-	0.25	-	-	V
LOW level output voltage (3mA at SDA pin)	V _{OL}	0	-	0.4	0	-	0.4	V
Output fall time from V _{IHmin} to V _{ILmax} with a bus capacitance from 10pF to 400pF	t _{of}	-	-	250	²⁰ _{+0.1C_b}	-	250	ns
Pulse width of spikes which must be suppressed by the input filter	t _{SP}	-	-	-	0	-	50	ns
Input current each I/O pin with an input voltage between 0.1V _{DD} and 0.9V _{DDmax}	I _i	-10	-	10	-10	-	10	μA
Capacitance for each I/O pin	C _i	-	-	10	-	-	10	pF
SCL clock frequency	f _{SCL}	-	-	100	-	-	400	kHz
Hold time (repeated) START condition.	t _{HD:STA}	4.0	-	-	0.6	-	-	μs
LOW period of the SCL clock	t _{LOW}	4.7	-	-	1.3	-	-	μs
HIGH period of the SCL clock	t _{HIGH}	4.0	-	-	0.6	-	-	μs
Set-up time for a repeated START condition	t _{SU:STA}	4.7	-	-	0.6	-	-	μs
Data hold time	t _{HD:DAT}	0	-	3.45	0	-	0.9	μs
Data set-up time	t _{SU:DAT}	250	-	-	100	-	-	ns
Rise time of both SDA and SCL signals	t _r	-	-	1000	-	-	300	ns
Fall time of both SDA and SCL signals	t _f	-	-	300	-	-	300	ns
Set-up time for STOP condition	t _{SU:STO}	4.0	-	-	0.6	-	-	μs
Bus free time between a STOP and START condition	t _{BUF}	4.7	-	-	1.3	-	-	μs
Capacitive load for each bus line	C _b	-	-	400	-	-	400	pF
Noise margin at the LOW level	V _{nL}	0.5	-	-	0.5	-	-	V
Noise margin at the HIGH level	V _{nH}	1	-	-	1	-	-	V

C_b ; total capacitance of one bus line in pF.

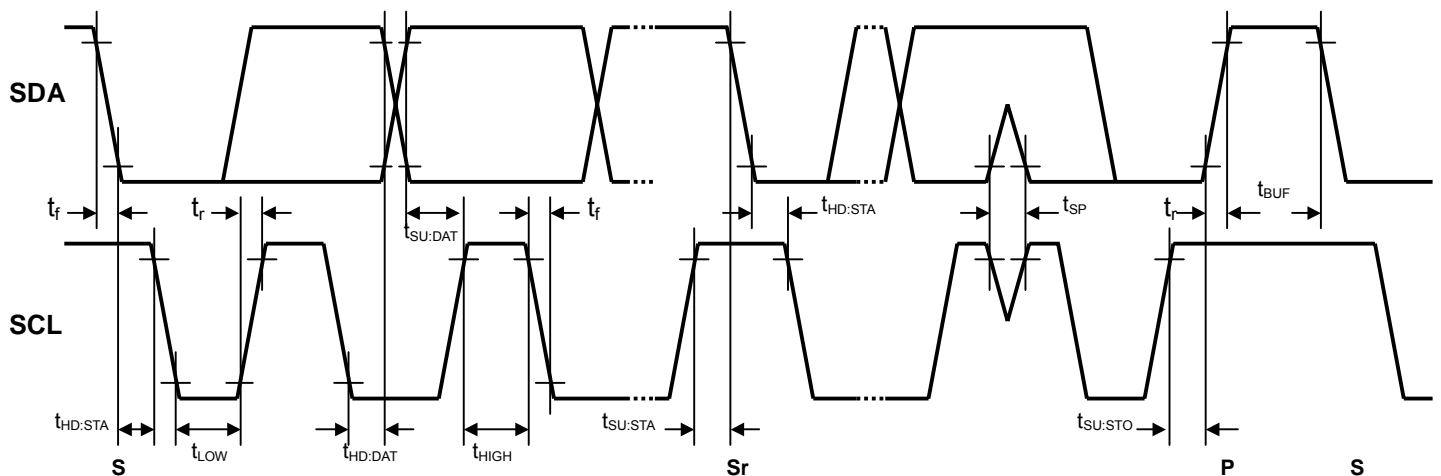

APPLICATION CIRCUIT (SDIP42)

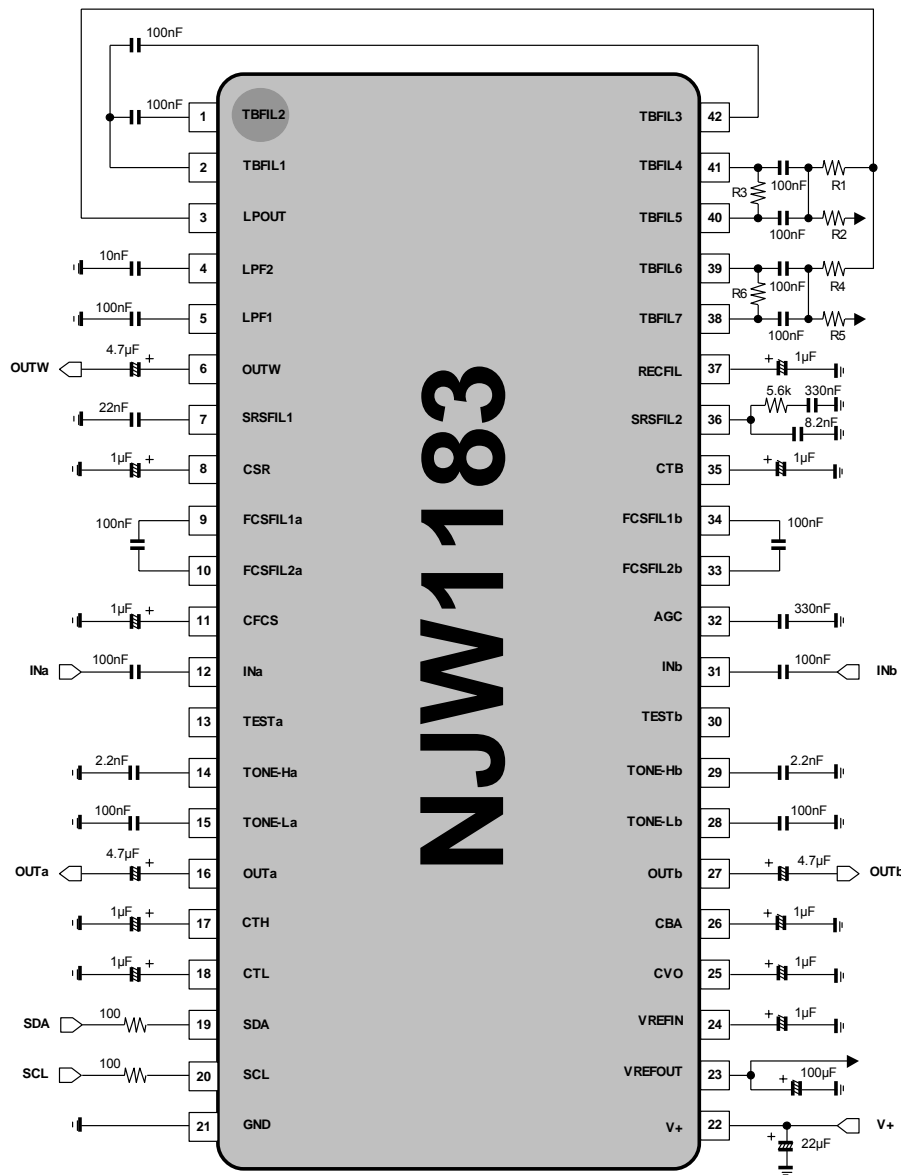

	SPEAKER SIZE		
	LARGE	MEDIUM	SMALL (TrueBass mode only)
R1	56.2k	21k	21k
R2	13k	3.09k	3.09k
R3	158k	42k	42k
R4	37.4k	37.4k	22.1k
R5	8.87k	8.87k	2.32k
R6	107k	107k	32k

The standard setting of speaker size is as follows. (Reference)

Large Mode: f_0 80Hz

Medium Mode: 80Hz < f_0 150Hz

Small Mode: 150Hz < f_0 250Hz

(NOTE1) Separate the I²C bus line and Signal line from the following terminals for avoiding digital noise problem and cross talk.

Pin No.	Symbol	Pin No.	Symbol	Pin No.	Symbol	Pin No.	Symbol
1	TBFIL2	7	SRSFIL1	28	TONE-Lb	38	TBFIL7
2	TBFIL1	9	FCSFIL1a	29	TONE-Hb	39	TBFIL6
3	LPFOUT	10	FCSFIL2a	33	FCSFIL2b	40	TBFIL5
4	LPF2	14	TONE-Ha	34	FCSFIL1b	41	TBFIL4
5	LPF1	15	TONE-La	36	SRSFIL2	42	TBFIL3

(NOTE2) Pin 13 and Pin30 should be opened.

■ DEFINITION OF I²C REGISTER

● I²C BUS FORMAT

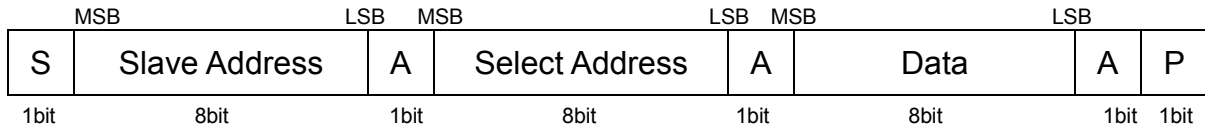

S: Starting Term
A: Acknowledge Bit
P: Ending Term

● SLAVE ADDRESS



R/W=0: Write mode for register setting
R/W=1: Not available

● CONTROL REGISTER TABLE

The select address sets each function (Volume, Balance, AGC, Tone Control, Surround etc.).
The auto-increment function cycles the select address as follows.
00H → 01H → 02H → 03H → 04H → 00H

Select Address	BIT							
	D7	D6	D5	D4	D3	D2	D1	D0
00H	VOL							
01H	CHS	BAL					SEL	
02H	BCB	BASS				AGC-SW	AGC-FLAT	
03H	BCT	TREB				FCS		
04H	MODE	TB			SUR			Don't Care

● CONTROL REGISTER DEFAULT VALUE

Control register default value is all "0".

Select Address	BIT							
	D7	D6	D5	D4	D3	D2	D1	D0
00H	0	0	0	0	0	0	0	0
01H	0	0	0	0	0	0	0	0
02H	0	0	0	0	0	0	0	0
03H	0	0	0	0	0	0	0	0
04H	0	0	0	0	0	0	0	0

■ I²C CONTROL COMMAND DESCRIPTION

● MASTER VOLUME CONTROL

Select Address	BIT							
	D7	D6	D5	D4	D3	D2	D1	D0
00H	VOL							

The volume controls both Ach and Bch by the 0.5dB step.

The volume is consisted of volume1 and volume2. The level is divided into half to each volume1 and volume2.

● BALANCE SETTINGS

Select Address	BIT							
	D7	D6	D5	D4	D3	D2	D1	D0
01H	CHS	BAL					SEL	

- CHS: Channel select for balance control
 "0": Ach "Bch is attenuated"
 "1": Bch "Ach is attenuated"
- BAL: Balance control for both Ach and Bch (1dB/Step)

● TONE CONTROL (Bass) and AGC SETTINGS

Select Address	BIT							
	D7	D6	D5	D4	D3	D2	D1	D0
02H	BCB	BASS				AGC-SW	AGC-FLAT	

- BCB : Bass Boost or Cut
 "0" : Cut
 "1" : Boost
- BASS : BASS Level
 Cut Level : -9 to 0dB(1dB/Step)
 Boost Level : 0 to +9dB(1dB/Step)
- AGC-SW : AGC ON/OFF Switch
 "0" : AGC OFF
 "1" : AGC ON (Default : 300mVrms)
- AGC-FLAT : AGC Flat Level

AGC Flat Level	AGC-FLAT	
	D1	D0
300mVrms	0	0
400mVrms	0	1
500mVrms	1	0
600mVrms	1	1

●TONE CONTROL (Treble) and FOCUS EFFECT SETTINGS

Select Address	BIT							
	D7	D6	D5	D4	D3	D2	D1	D0
03H	BCT	TREB				FCS		

- BCT : Treble Boost or Cut
 "0" : Cut
 "1" : Boost
- TREB : Treble Level
 Cut Level : -9 to 0dB(1dB/Step)
 Boost Level : 0 to +9dB(1dB/Step)

●FCS: FOCUS Effect

FOCUS Effect	FCS		
	D2	D1	D0
OFF	0	0	0
Effect 1 (Minimum)	0	0	1
Effect 2	0	1	0
Effect 3	0	1	1
Effect 4 (Maximum)	1	Don't Care	Don't Care

● WOW Output Mode Select, TruBass and Surround EFFECT SETTINGS

Select Address	BIT							
	D7	D6	D5	D4	D3	D2	D1	D0
04H	MODE	TB			SUR			Don't Care

●MODE : Output Mode Select

MODE	D7	Output terminals
2ch	0	OUTa, OUTb
2.1ch	1	OUTa, OUTb, OUTw

●TB : TruBass Effect

TruBass Effect	TB		
	D6	D5	D4
OFF	0	0	0
Effect 1 (Minimum)	0	0	1
Effect 2	0	1	0
Effect 3	0	1	1
Effect 4 (Maximum)	1	Don't Care	Don't Care

NOTE)

	MODE=2ch		MODE=2.1ch	
	TB=OFF	TB=Effect1-4	TB=OFF	TB=Effect1-4
OUTa(14pin), OUTb(25pin)	Bypass ^{NOTE1)}	TB effect (WOW)	Bypass ^{NOTE1)}	
OUTw(1pin)	No Output		No Output	TB effect

NOTE1) TruBass is not effective.

•SUR : Surround Effect

Surround Effect	SUR		
	D3	D2	D1
OFF	0	0	0
Simulated Stereo ^{NOTE2)}	0	0	1
Effect 1 (Minimum)	0	1	0
Effect 2	0	1	1
Effect 3	1	0	0
Effect 4 (Maximum)	1	0	1
	1	1	Don't Care

NOTE2) Simulated Stereo dose not adapt to SRS WOW.

■ Master Volume (Select Address: 00H)

		VOL							
Gain(dB)	HEX	D7	D6	D5	D4	D3	D2	D1	D0
0	FF	1	1	1	1	1	1	1	1
-1	FD	1	1	1	1	1	1	0	1
-2	FB	1	1	1	1	1	0	1	1
-3	F9	1	1	1	1	1	0	0	1
-4	F7	1	1	1	1	0	1	1	1
-5	F5	1	1	1	1	0	1	0	1
-6	F3	1	1	1	1	0	0	1	1
-7	F1	1	1	1	1	0	0	0	1
-8	EF	1	1	1	0	1	1	1	1
-9	ED	1	1	1	0	1	1	0	1
-10	EB	1	1	1	0	1	0	1	1
-11	E9	1	1	1	0	1	0	0	1
-12	E7	1	1	1	0	0	1	1	1
-13	E5	1	1	1	0	0	1	0	1
-14	E3	1	1	1	0	0	0	1	1
-15	E1	1	1	1	0	0	0	0	1
-16	DF	1	1	0	1	1	1	1	1
-17	DD	1	1	0	1	1	1	0	1
-18	DB	1	1	0	1	1	0	1	1
-19	D9	1	1	0	1	1	0	0	1
-20	D7	1	1	0	1	0	1	1	1
-21	D5	1	1	0	1	0	1	0	1
-22	D3	1	1	0	1	0	0	1	1
-23	D1	1	1	0	1	0	0	0	1
-24	CF	1	1	0	0	1	1	1	1
-25	CD	1	1	0	0	1	1	0	1
-26	CB	1	1	0	0	1	0	1	1
-27	C9	1	1	0	0	1	0	0	1
-28	C7	1	1	0	0	0	1	1	1
-29	C5	1	1	0	0	0	1	0	1
-30	C3	1	1	0	0	0	0	1	1
-31	C1	1	1	0	0	0	0	0	1
-32	BF	1	0	1	1	1	1	1	1
-33	BD	1	0	1	1	1	1	0	1
-34	BB	1	0	1	1	1	0	1	1
-35	B9	1	0	1	1	1	0	0	1
-36	B7	1	0	1	1	0	1	1	1
-37	B5	1	0	1	1	0	1	0	1
-38	B3	1	0	1	1	0	0	1	1
-39	B1	1	0	1	1	0	0	0	1
-40	AF	1	0	1	0	1	1	1	1
-41	AD	1	0	1	0	1	1	0	1
-42	AB	1	0	1	0	1	0	1	1

■MASTER VOLUME (Cont'd)

		VOL							
Gain(dB)	HEX	D7	D6	D5	D4	D3	D2	D1	D0
-43	A9	1	0	1	0	1	0	0	1
-44	A7	1	0	1	0	0	1	1	1
-45	A5	1	0	1	0	0	1	0	1
-46	A3	1	0	1	0	0	0	1	1
-47	A1	1	0	1	0	0	0	0	1
-48	9F	1	0	0	1	1	1	1	1
-49	9D	1	0	0	1	1	1	0	1
-50	9B	1	0	0	1	1	0	1	1
-51	99	1	0	0	1	1	0	0	1
-52	97	1	0	0	1	0	1	1	1
-53	95	1	0	0	1	0	1	0	1
-54	93	1	0	0	1	0	0	1	1
-55	91	1	0	0	1	0	0	0	1
-56	8F	1	0	0	0	1	1	1	1
-57	8D	1	0	0	0	1	1	0	1
-58	8B	1	0	0	0	1	0	1	1
-59	89	1	0	0	0	1	0	0	1
-60	87	1	0	0	0	0	1	1	1
-61	85	1	0	0	0	0	1	0	1
-62	83	1	0	0	0	0	0	1	1
-63	81	1	0	0	0	0	0	0	1
-64	7F	0	1	1	1	1	1	1	1
-65	7D	0	1	1	1	1	1	0	1
-66	7B	0	1	1	1	1	0	1	1
-67	79	0	1	1	1	1	0	0	1
-68	77	0	1	1	1	0	1	1	1
-69	75	0	1	1	1	0	1	0	1
-70	73	0	1	1	1	0	0	1	1
-71	71	0	1	1	1	0	0	0	1
-72	6F	0	1	1	0	1	1	1	1
-73	6D	0	1	1	0	1	1	0	1
-74	6B	0	1	1	0	1	0	1	1
-75	69	0	1	1	0	1	0	0	1
-76	67	0	1	1	0	0	1	1	1
-77	65	0	1	1	0	0	1	0	1
-78	63	0	1	1	0	0	0	1	1
-79	61	0	1	1	0	0	0	0	1
-80	5F	0	1	0	1	1	1	1	1
.
.
-90	4B	0	1	0	0	1	0	1	1
.
.
-100	37	0	0	1	1	0	1	1	1
Mute	00	0	0	0	0	0	0	0	0

■ Balance (Select Address: 01H)

Channel Setting (CHS)	D7
Attenuated Bch Gain	0
Attenuated Ach Gain	1

Gain(dB)	BAL				
	D6	D5	D4	D3	D2
0	0	0	0	0	0
-1	0	0	0	0	1
-2	0	0	0	1	0
-3	0	0	0	1	1
-4	0	0	1	0	0
-5	0	0	1	0	1
-6	0	0	1	1	0
-7	0	0	1	1	1
-8	0	1	0	0	0
-9	0	1	0	0	1
-10	0	1	0	1	0
-11	0	1	0	1	1
-12	0	1	1	0	0
-13	0	1	1	0	1
-14	0	1	1	1	0
-15	0	1	1	1	1
-16	1	0	0	0	0
-17	1	0	0	0	1
-18	1	0	0	1	0
-19	1	0	0	1	1
-20	1	0	1	0	0
-21	1	0	1	0	1
-22	1	0	1	1	0
-23	1	0	1	1	1
-24	1	1	0	0	0
-25	1	1	0	0	1
-26	1	1	0	1	0
-27	1	1	0	1	1
-28	1	1	1	0	0
-29	1	1	1	0	1
-30	1	1	1	1	0
MUTE	1	1	1	1	1

■ **Tone Control Bass (Select Address: 02H)**

Bass	BCB
Cut or Boost	D7
Cut	0
Boost	1

		BASS			
Cut Gain(dB)	Boost Gain(dB)	D6	D5	D4	D3
-9	9	1	0	0	1
-8	8	1	0	0	0
-7	7	0	1	1	1
-6	6	0	1	1	0
-5	5	0	1	0	1
-4	4	0	1	0	0
-3	3	0	0	1	1
-2	2	0	0	1	0
-1	1	0	0	0	1
0	0	0	0	0	0

■ **Tone Control Treble (Select Address: 03H)**

Treble	BCT
Cut or Boost	D7
Cut	0
Boost	1

		TREB			
Cut Gain(dB)	Boost Gain(dB)	D6	D5	D4	D3
-9	9	1	0	0	1
-8	8	1	0	0	0
-7	7	0	1	1	1
-6	6	0	1	1	0
-5	5	0	1	0	1
-4	4	0	1	0	0
-3	3	0	0	1	1
-2	2	0	0	1	0
-1	1	0	0	0	1
0	0	0	0	0	0

TYPICAL CHARACTERISTICS

Operating Current vs. Power Supply Voltage

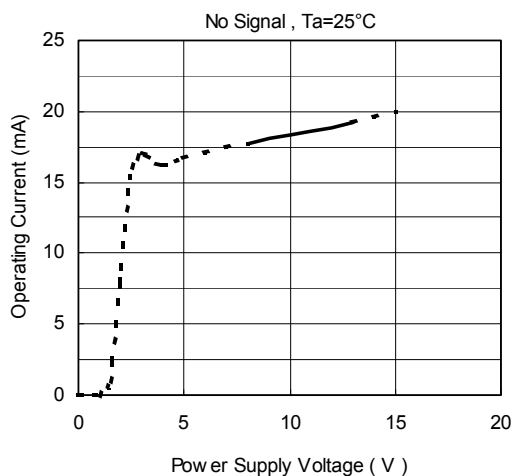

Operating Current vs. Ambient Temperature

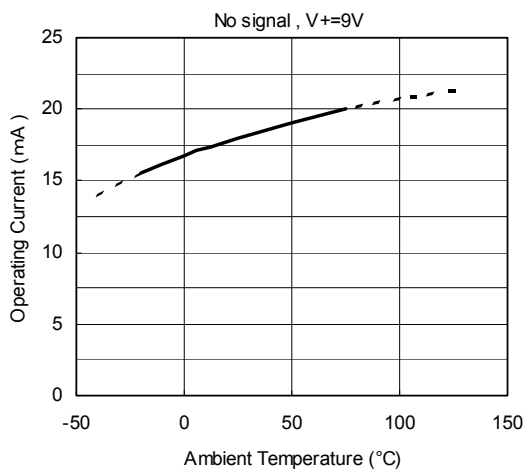

Reference Voltage vs. Power Supply Voltage

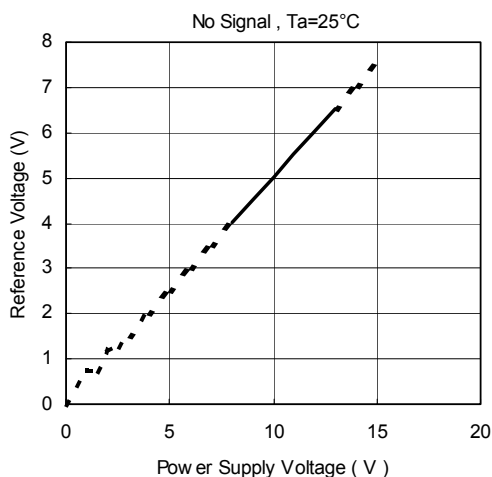

Reference Voltage vs. Ambient temperature

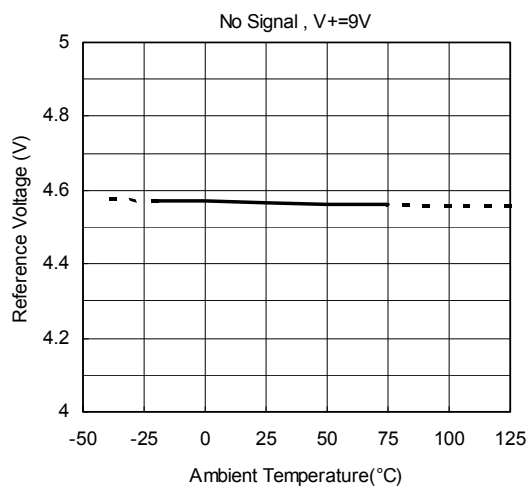

Output Noise Voltage (OUT) vs. Frequency

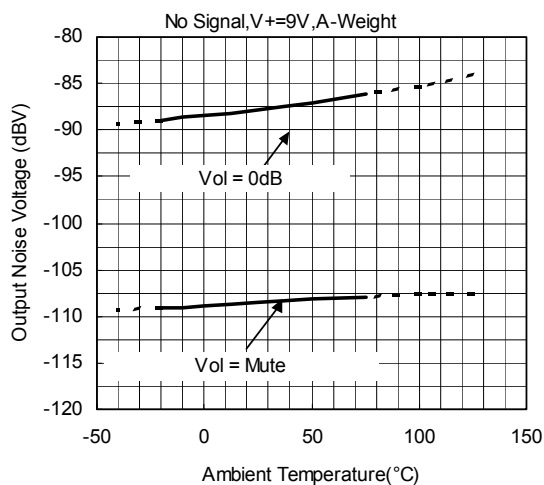

Mute Level vs. Ambient Temperature

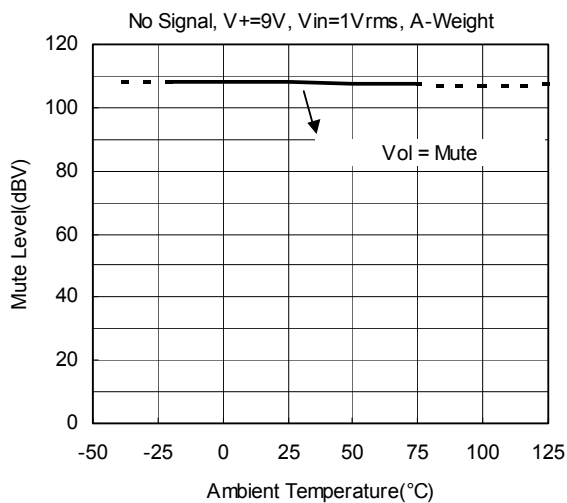

TYPICAL CHARACTERISTICS

Total Harmonic Distortion vs. Input Voltage

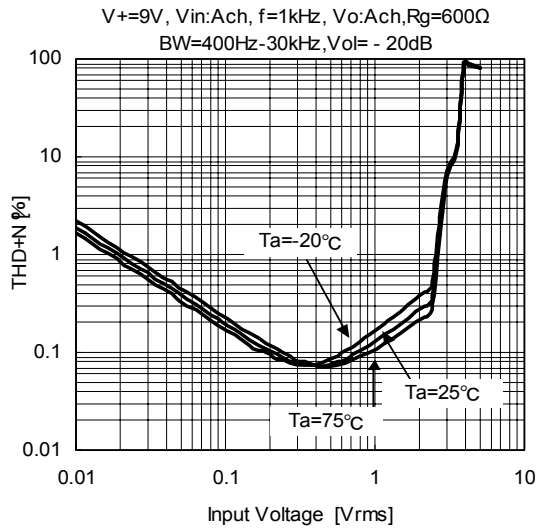

Total Harmonic Distortion vs. Input Voltage

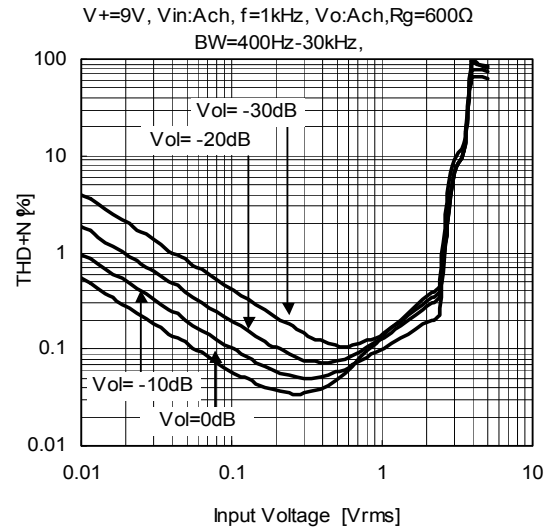

Total Harmonic Distortion vs. Output Voltage

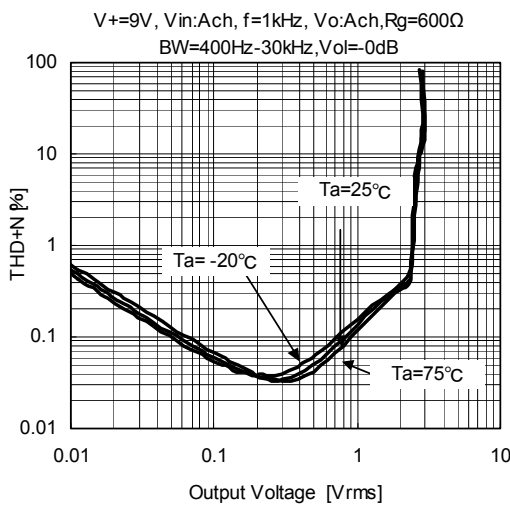

Total Harmonic Distortion vs. Output Voltage

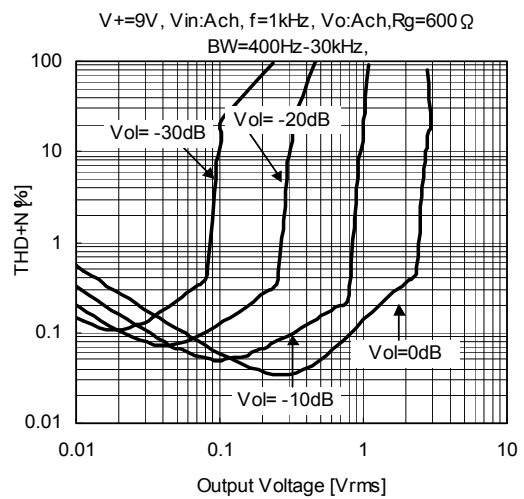

Channel Separation vs. Frequency

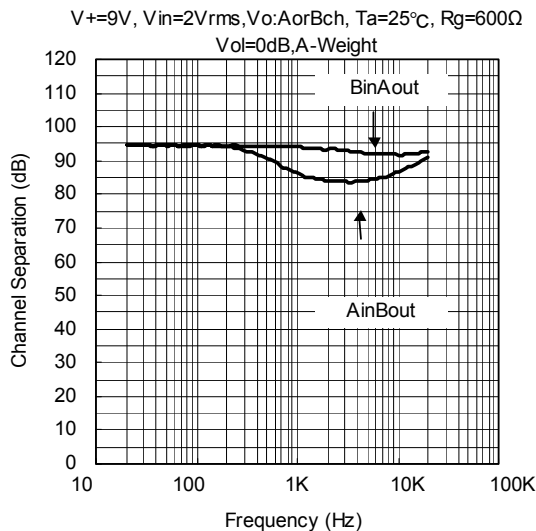

TYPICAL CHARACTERISTICS

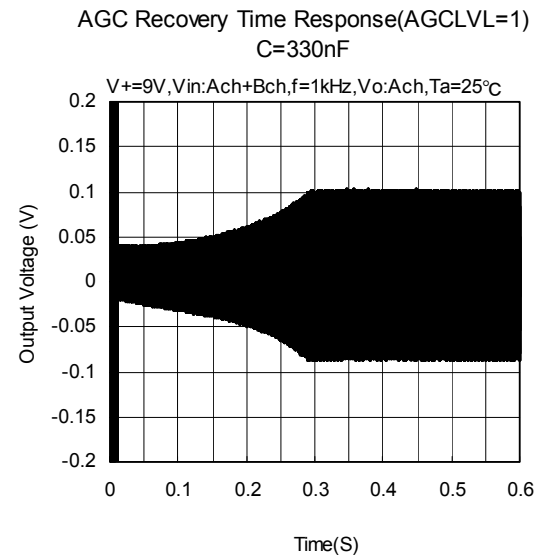
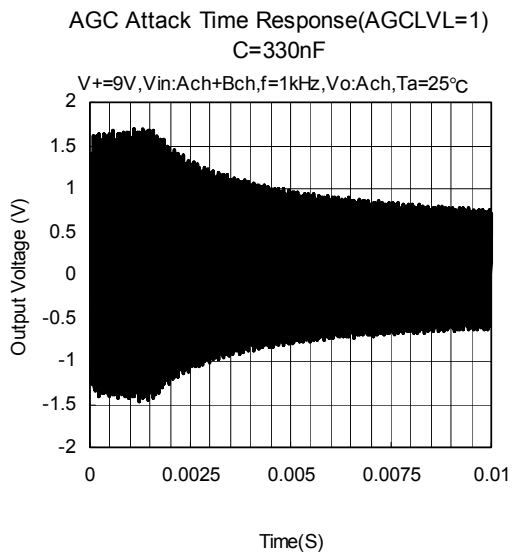
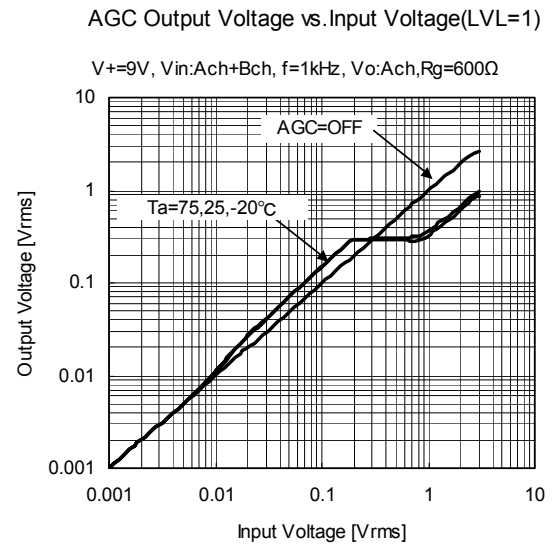
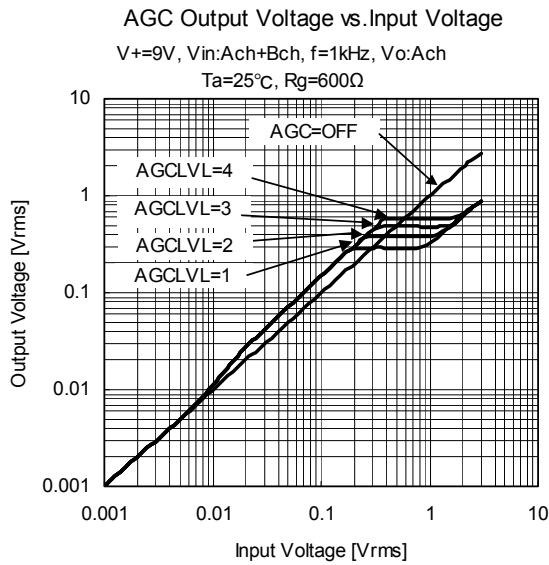
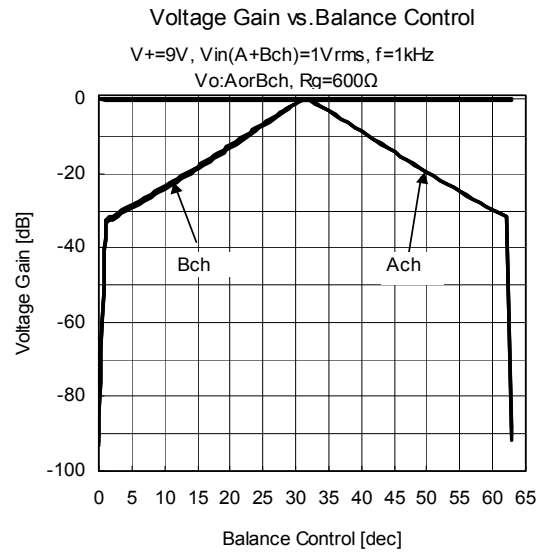
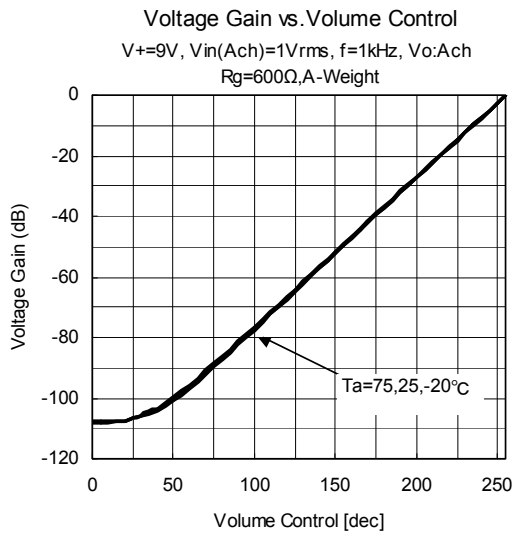

TYPICAL CHARACTERISTICS

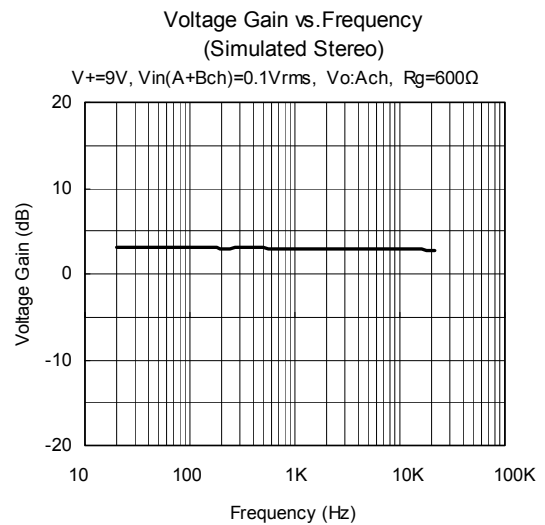
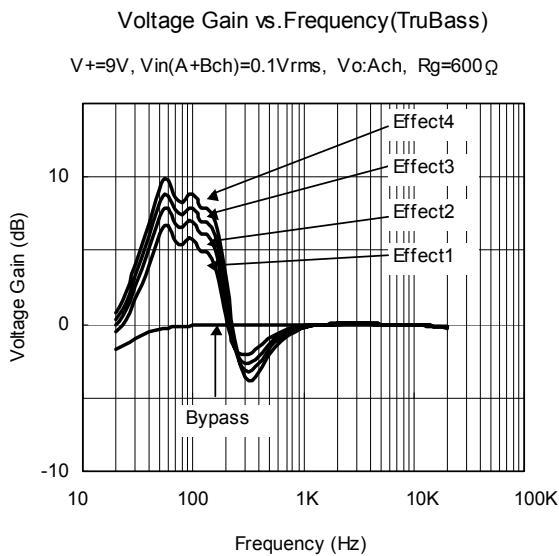
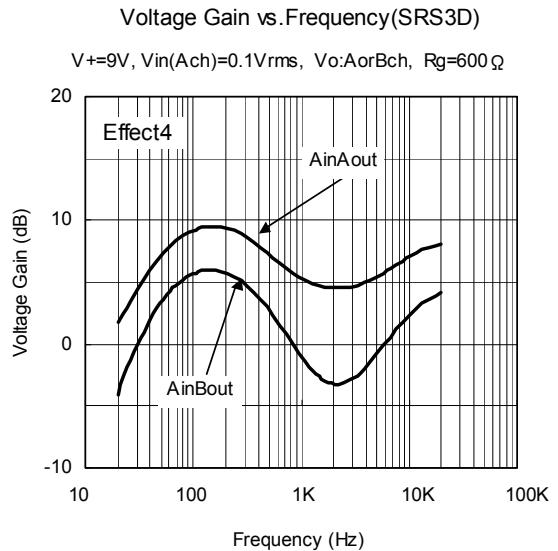
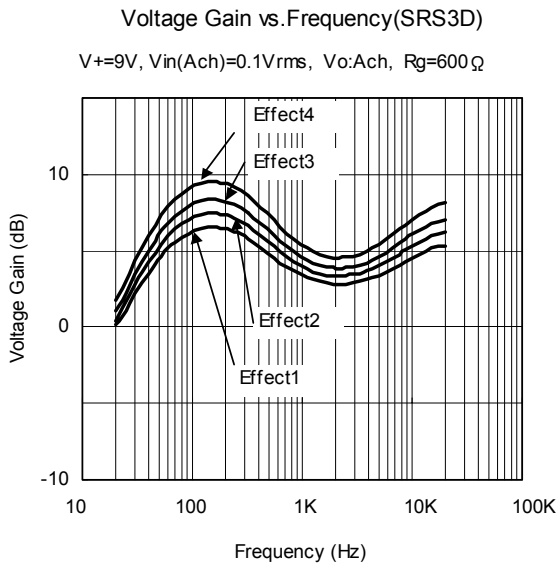
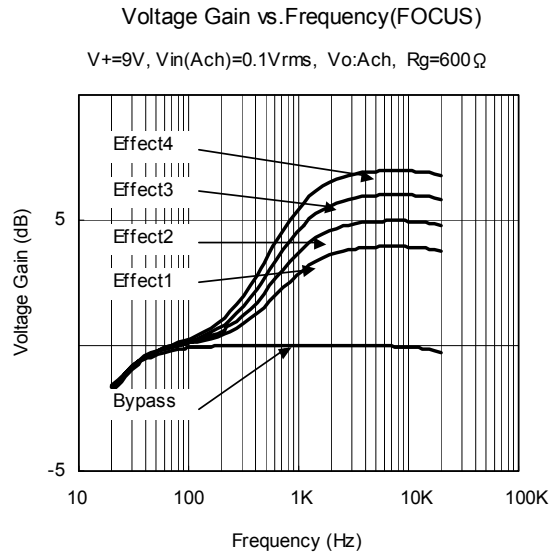
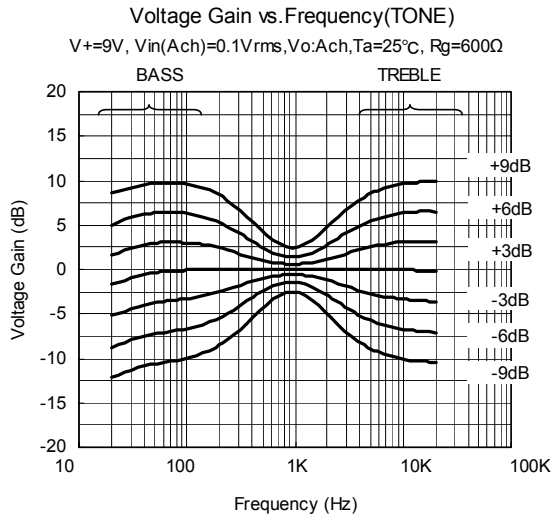

■NOTE

The WOW technology right incorporated in the **NJW1183** are owned by SRS Labs, a U.S. Corporation and licensed to New Japan Radio Co., Ltd. Purchaser of **NJW1183** must sign a license for use of the chip and display of the SRS Labs trademarks. Any products incorporating the **NJW1183** must be sent to SRS Labs for review. WOW is protected under U.S. and foreign patents issued and/or pending. WOW, SRS and the  symbol are trademarks of SRS Labs, Inc. in the United States and selected foreign countries. Neither the purchase of the **NJW1183**, nor the corresponding sale of audio enhancement equipment conveys the right to sell commercialized recordings made with any SRS technology.

SRS Labs requires all set makers to comply with all rules and regulations as outlined in the SRS Trademark Usage Manual separately provided.

For further information, please contact:

SRS Labs, Inc.

2909 Daimler Street, Santa Ana, CA 92705 USA

Tel: 949-442-1070 Fax: 949-852-1099 <http://www.srslabs.com>

[CAUTION]

The specifications on this databook are only given for information, without any guarantee as regards either mistakes or omissions. The application circuits in this databook are described only to show representative usages of the product and not intended for the guarantee or permission of any right including the industrial rights.