



AUDIO PROCESSOR with Input Selector

■ GENERAL DESCRIPTION

The **NJW1185** is a sound processor with input selector includes all of functions processing audio signal for TV, such as input selector, tone control, balance, volume, and mute functions.

Also the **NJW1185** includes eala and voice enhancement.

The eala reproduces a natural surround sound with clear vocal orientation. And also, voice enhancement gives clear sound such as dialogs.

All of internal status and variables are controlled by I²C BUS interface.

■ PACKAGE OUTLINE

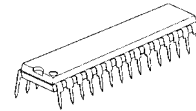

NJW1185L

■ FEATURES

- Operating Voltage 7.5 to 13V
- 6ch Input Selector
- Tone Control Bass / Treble
- eala(NJRC Original Surround System)
- Simulated Stereo
- Voice Enhancement System
- I²C BUS Interface
- Bi-CMOS Technology
- Package Outline SDIP32

■ BLOCK DIAGRAM

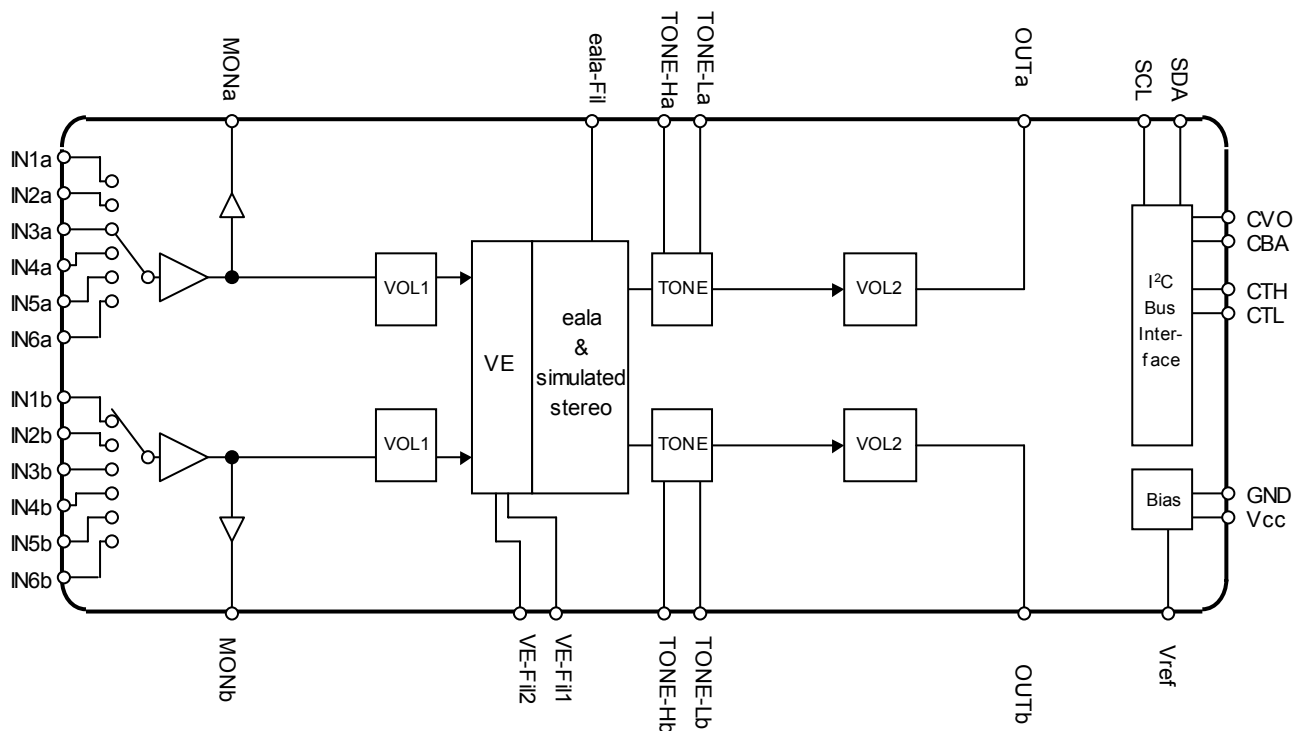

■PIN CONFIGURATION

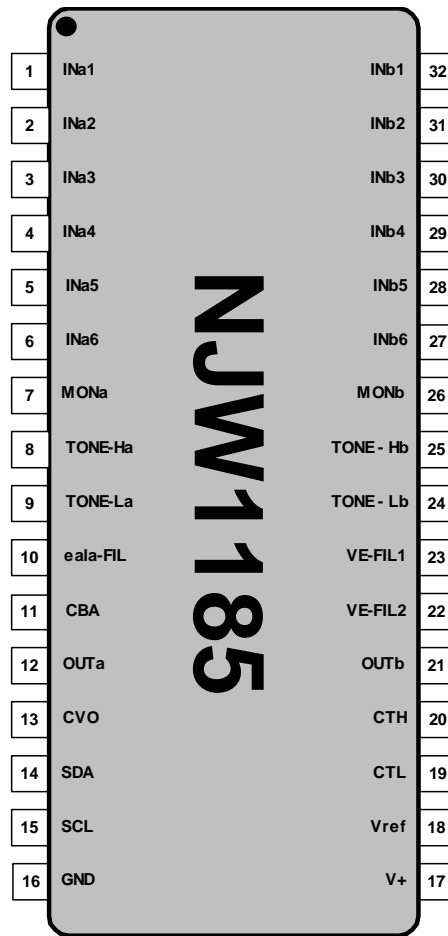

No.	Symbol	Function	No.	Symbol	Function
1	INa1	Ach input terminal 1	17	V+	Supply voltage terminal
2	INa2	Ach input terminal 2	18	Vref	Reference voltage terminal
3	INa3	Ach input terminal 3	19	CTL	DAC output terminal for tone control (bass)
4	INa4	Ach input terminal 4	20	CTH	DAC output terminal for tone control (treble)
5	INa5	Ach input terminal 5	21	OUTb	Bch output terminal
6	INa6	Ach input terminal 6	22	VE-FIL2	Voice Enhancement Filter Capacitor terminal 2
7	MONa	Ach monitor output terminal	23	VE-FIL1	Voice Enhancement Filter Capacitor terminal 1
8	TONE-Ha	Ach tone control (treble) filter terminal	24	TONE-Lb	Bch tone control (bass) filter terminal
9	TONE-La	Ach tone control (bass) filter terminal	25	TONE-Hb	Bch tone control (treble) filter terminal
10	eala-FIL	eala Filter Capacitor terminal	26	MONb	Bch monitor output terminal
11	CBA	Pop Noise Reduction Capacitor for Balance terminal	27	INb6	Bch input terminal 6
12	OUTa	Ach output terminal	28	INb5	Bch input terminal 5
13	CVO	Pop Noise Reduction Capacitor for Volume terminal	29	INb4	Bch input terminal 4
14	SDA	I ² C data terminal	30	INb3	Bch input terminal 3
15	SCL	I ² C clock terminal	31	INb2	Bch input terminal 2
16	GND	Ground terminal	32	INb1	Bch input terminal 1

■ ABSOLUTE MAXIMUM RATING (Ta=25°C)

PARAMETER	SYMBOL	RATING	UNIT
Supply Voltage	V ⁺	15	V
Power Dissipation	P _D	700	mW
Operating Temperature Range	Topr	-20 to +75	°C
Storage Temperature Range	Tstg	-40 to +125	°C

■ ELECTRICAL CHARACTERISTICS

(Ta=25°C, V+=9V, R_L=47kΩ, Vin=100mVrms/1kHz unless otherwise specified)

PARAMETER	SYMBOL	Condition	Input			Output	MIN.	TYP.	MAX.	UNIT
			INa	INb						
Operating Voltage	V ⁺		-	-	-	7.5	9.0	13.0	V	
Supply Current	I _{CC}	No Signal	-	-	-	-	13	25	mA	
Reference Voltage	V _{REF}	No Signal	-	-	-	4.0	4.5	5.0	V	
Maximum Input Voltage	V _{IM}	VOL=-20dB, THD=10%	V _{in}	-	OUTa	2.8	3.0	-	Vrms	
			-	V _{in}	OUTb					
			-	V _{in}	OUTb					
Maximum Output Voltage	V _{OM}	VOL=0dB, THD=1%	V _{in}	-	OUTa	-	2.5	-	Vrms	
			-	V _{in}	OUTb					
Monitor Output Gain	G _{VMON}	MON OUT	V _{in}	-	OUTa	-	0	-	dB	
			-	V _{in}	OUTb					
Channel Balance	G _{CB}	VOL=0dB	-	-	-	-1.5	0.0	1.5	dB	
Balance Boost A	BA _{BST}	CHS="0", BAL="111111"	V _{in}	V _{in}	OUTa	-2.0	0.0	2.0	dB	
Balance Cut A	BA _{CUT}	CHS="1", BAL="111111" Vin = 1Vrms	V _{in}	V _{in}	OUTa	-	-	-70	dB	
Balance Boost B	BB _{BST}	CHS="1", BAL="111111"	V _{in}	V _{in}	OUTb	-2.0	0.0	2.0	dB	
Balance Cut B	BB _{CUT}	CHS="0", BAL="111111" Vin = 1Vrms	V _{in}	V _{in}	OUTb	-	-	-70	dB	
Total Harmonic Distortion	THD	Vo=0.5Vrms, BW=400Hz to 30kHz	V _{in}	-	OUTa	-	-	0.5	%	
			-	V _{in}	OUTb					
Maximum Gain	G _{VMAX}	VOL=0dB	V _{in}	-	OUTa	-2.0	0.0	2.0	dB	
			-	V _{in}	OUTb					
Minimum Gain	G _{VMIN}	VOL=MUTE Vin=1Vrms	V _{in}	-	OUTa	-	-	-80	dB	
			-	V _{in}	OUTb					
Cross Talk	CT	Vin=1Vrms A-Weighted Selected Input : No signal Unselected Inputs : Signal	V _{in}	-	OUTa	-	-	-70	dB	
			-	V _{in}	OUTb					
Channel Separation	CS	Vin=1Vrms A-Weighted	V _{in}	-	OUTb	-	-80	-70	dB	
			-	V _{in}	OUTa					
Output Noise Voltage 1	V _{NO1}	VOL=0dB A-Weighted	-	-	-	-	-90 (31.6)	-85 (56.2)	dBV (μVrms)	
Output Noise Voltage 2	V _{NO2}	VOL=MUTE A-Weighted	-	-	-	-	-106 (5.0)	-96 (15.8)	dBV (μVrms)	

BW : Band Width

■ ELECTRICAL CHARACTERISTICS

(Ta=25°C, V+=9V, RL=47kΩ, Vin=100mVrms/1kHz unless otherwise specified)

PARAMETER	SYMBOL	Condition				MIN.	TYP.	MAX.	UNIT
		Input		Output					
		INa	INb						
◆ TONE									
High Frequency Boost	HF _{BST}	BCT="1" TREB=+15dB, f=10kHz	V _{in}	-	OUTa	12.5	15.0	17.5	dB
			-	V _{in}	OUTb				
High Frequency Flat	HF _{FLT}	TREB=0, f=10kHz	V _{in}	-	OUTa	-2.0	0.0	2.0	dB
			-	V _{in}	OUTb				
High Frequency Cut	HF _{CUT}	BCT="0" TREB=-15dB, f=10kHz	V _{in}	-	OUTa	-	-15.0	-	dB
			-	V _{in}	OUTb				
Low Frequency Boost	LF _{BST}	BCB="1" BASS=+15dB, f=100Hz	V _{in}	-	OUTa	12.5	15.0	17.5	dB
			-	V _{in}	OUTb				
Low Frequency Flat	LF _{FLT}	BASS=0, f=100Hz	V _{in}	-	OUTa	-2.0	0.0	2.0	dB
			-	V _{in}	OUTb				
Low Frequency Cut	LF _{CUT}	BCB="0" BASS=-15dB, f=100Hz	V _{in}	-	OUTa	-	-15.0	-	dB
			-	V _{in}	OUTb				
◆ SURROUND									
Surround Gain1	SR _{GAIN1}	f=100Hz, SUR1 Surround Effect1	V _{in}	-	OUTa	8.0	10.0	12.0	dB
			-	V _{in}	OUTb				
Surround Gain2	SR _{GAIN2}	f=100Hz, SUR1 Surround Effect1	V _{in}	-	OUTb	5.0	7.0	9.0	dB
			-	V _{in}	OUTa				
Surround Gain3	SR _{GAIN3}	f=100Hz, SUR1 Surround Effect2	V _{in}	-	OUTa	14.0	16.0	18.0	dB
			-	V _{in}	OUTb				
Simulated Stereo1	SR _{SIM1}	f=1kHz, Simulated Stereo	V _{in}	V _{in}	OUTa	1.0	3.0	5.0	dB
Simulated Stereo2	SR _{SIM2}	f=1kHz, Simulated Stereo	V _{in}	V _{in}	OUTb	1.0	3.0	5.0	dB
◆ VOICE ENHANCEMENT									
PARAMETER	SYMBOL	Condition				MIN.	TYP.	MAX.	UNIT
		Input		Output					
		INa	INb						
Voice Enhancement Gain 1	VE _{GAIN1}	f=5kHz, VE1 Voice Enhancement Effect 1	V _{in}	V _{in}	OUTa	3.5	6.0	8.5	dB
			V _{in}	V _{in}	OUTb				
Voice Enhancement Gain 2	VE _{GAIN2}	f=5kHz, VE2 Voice Enhancement Effect 2	V _{in}	V _{in}	OUTa	7.5	10.0	12.5	dB
			V _{in}	V _{in}	OUTb				
Voice Enhancement Gain 3	VE _{GAIN3}	f=5kHz, VE3 Voice Enhancement Effect 3	V _{in}	V _{in}	OUTa	10.5	13.0	15.5	dB
			V _{in}	V _{in}	OUTb				

■ TERMINAL DESCRIPTION

PIN NO.	SYMBOL	FUNCTION	EQUIVALENT CIRCUIT	TERMINAL DC VOLTAGE
1, 32 2, 31 3, 30 4, 29 5, 28 6, 27	INa1, INb1 INa2, INb2 INa3, INb3 INa4, INb4 INa5, INb5 INa6, INb6	Ach Input terminal 1, Bch Input terminal 1 Ach Input terminal 2, Bch Input terminal 2 Ach Input terminal 3, Bch Input terminal 3 Ach Input terminal 4, Bch Input terminal 4 Ach Input terminal 5, Bch Input terminal 5 Ach Input terminal 6, Bch Input terminal 6		$V^+/2$
7 26 12 21	MONa MONb OUTa OUTb	Ach monitor output terminal Bch monitor output terminal Ach Output terminal Bch Output terminal		$V^+/2$
8 25 9 24 23	TONE-Ha TONE-Hb TONE-La TONE-Lb VE-FIL1	Ach tone control (treble) filter terminal Bch tone control (treble) filter terminal Ach tone control (bass) filter terminal Bch tone control (bass) filter terminal Voice Enhancement Filter Capacitor terminal 1		$V^+/2$
10	eala-FIL	eala Filter Capacitor terminal		$V^+/2$

■ TERMINAL DESCRIPTION

PIN NO.	SYMBOL	FUNCTION	EQUIVALENT CIRCUIT	TERMINAL DC VOLTAGE
11 19 20	CBA CTL CTH	Pop Noise Reduction Capacitor for Balance terminal DAC output terminal for tone control (bass) DAC output terminal for tone control (treble)	<p>PIN.11: 24k PIN.19,20:8k</p>	$V^+/2 - 1.4$
13	CVO	Pop Noise Reduction Capacitor for Volume terminal	<p>8k</p>	$V^+/2 - 0.7$
14 15	SDA SCL	I ² C data terminal I ² C clock terminal	<p>VREG 5V V+ 9V</p> <p>4k 8k</p> <p>SCL:GND SDA:ACK</p>	-
18	Vref	Reference voltage terminal	<p>220k 220k</p>	$V^+/2$

■ TERMINAL DESCRIPTION

PIN NO.	SYMBOL	FUNCTION	EQUIVALENT CIRCUIT	TERMINAL DC VOLTAGE
22	VE-FIL2	Voice Enhancement Filter Capacitor terminal 2	<p>The diagram shows an equivalent circuit for terminal 22. On the left, there is a feedback loop consisting of two transistors. The top transistor's collector is connected to the base of the bottom transistor, and the bottom transistor's emitter is grounded. The base of the top transistor is connected to a node labeled 'FB'. A resistor labeled '8k' connects the 'FB' node to the output node. The output node is also connected to a terminal symbol (a circle). The output node is clamped to ground by two diodes connected in series, one pointing up and one pointing down.</p>	$V^+/2$

APPLICATION CIRCUIT

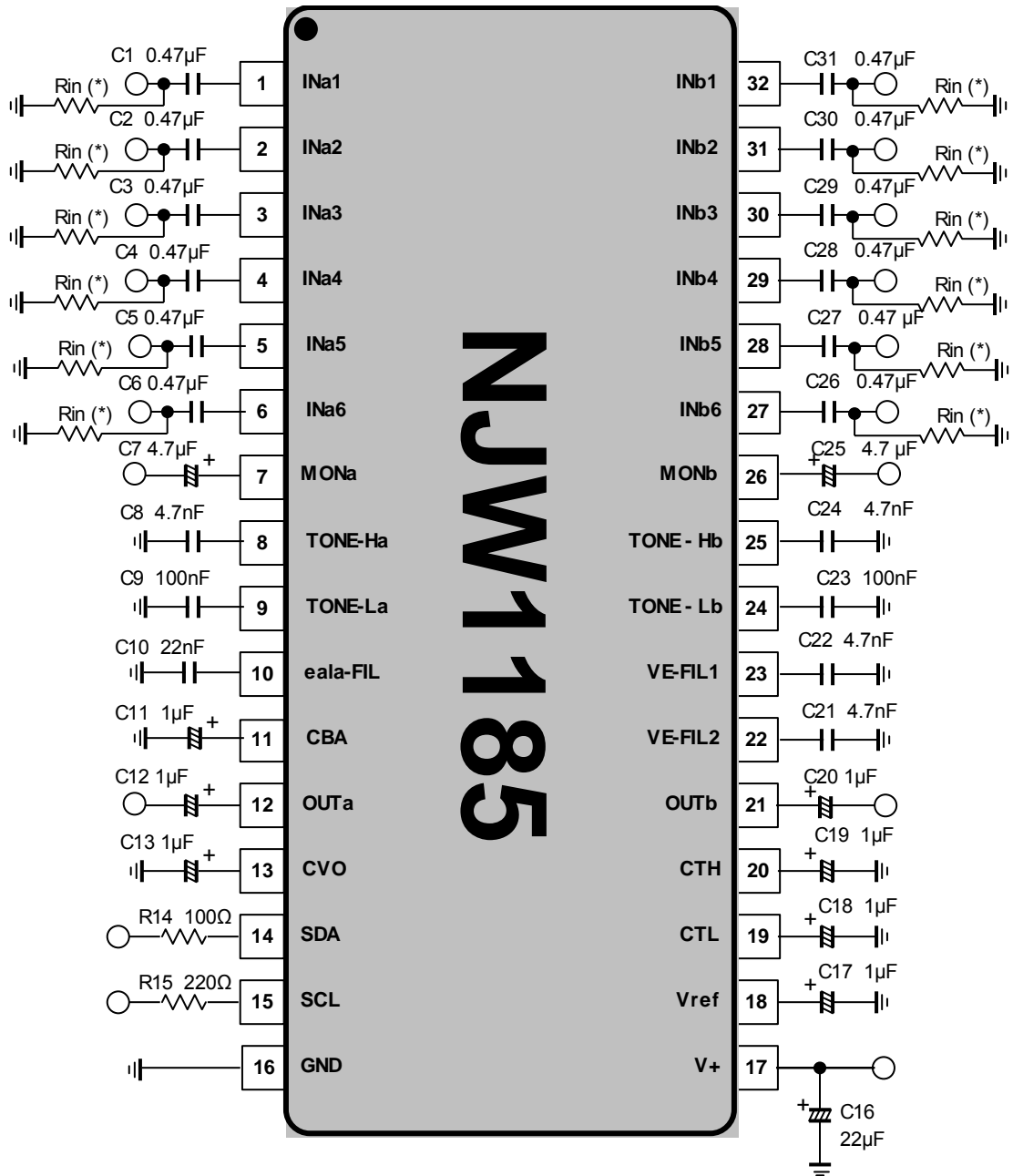

(*) Separate the I²C bus line and Signal line from the following terminals for avoiding digital noise problem and cross talk.

Pin No.	Symbol	Pin No.	Symbol
8	TONE-Ha	23	VE-Fil1
9	TONE-La	24	TONE-Lb
10	eala-Fil	25	TONE-Hb
22	VE-Fil2	-	-

(*) Cross talk performance may be effected by PCB patterning and Input resistor "Rin" in relation to input impedance. Widen intervals of input lines (1pin to 6pin, 27pin to 32pin) and put guard patterns (ground patterns) among input lines and Monitor outputs (7pin, 26pin) for avoiding cross talk problem.
Further, cross talk performance may be effected by input resistor "Rin". The recommended "Rin" value is 20kΩ or less. In consideration of an actual operating condition, please decide Rin values after evaluating. (The NJW1185 input impedances are 48kΩtyp.)

I²C BUS CHARACTERISTICS (SDA, SCL)

I²C BUS Load Conditions

STANDARD MODE : Pull up resistance 4kΩ (Connected to +5V), Load capacitance 200pF (Connected to GND)

FAST MODE : Pull up resistance 4kΩ (Connected to +5V), Load capacitance 50pF (Connected to GND)

PARAMETER	SYM BOL	STANDARD			FAST			UNIT
		MIN	TYP	MAX	MIN	TYP	MAX	
Low Level Input Voltage	V _{IL}	0.0	-	1.5	0.0	-	1.5	V
High Level Input Voltage	V _{IH}	2.7	-	5.5	2.7	-	5.5	V
Hysteresis of Schmitt Trigger Inputs	V _{hys}	-	-	-	0.25	-	-	V
LOW level Output Voltage (3mA at SDA pin)	V _{OL}	0	-	0.4	0	-	0.4	V
Output Fall Time From V _{IHmin} to V _{ILmax} with a Bus Capacitance from 10pF to 400pF	t _{of}	-	-	250	20 +0.1C _b	-	250	ns
Pulse width of spikes which must be suppressed by the input filter	t _{SP}	-	-	-	0	-	50	ns
Input Current each I/O pin with an Input Voltage between 0.1 and 0.9V _{DDmax}	I _i	-10	-	10	-10	-	10	μA
Capacitance for each I/O pin	C _i	-	-	10	-	-	10	pF
SCL Clock Frequency	f _{SCL}	-	-	100	-	-	400	kHz
Data Transfer Start Minimum Waiting Time	t _{HD:STA}	4.0	-	-	0.6	-	-	μs
Low Level Clock Pulse Width	t _{LOW}	4.7	-	-	1.3	-	-	μs
High Level Clock Pulse Width	t _{HIGH}	4.0	-	-	0.6	-	-	μs
Minimum Start Preparation Waiting Time	t _{SU:STA}	4.7	-	-	0.6	-	-	μs
Minimum Data Hold Time	t _{HD:DAT}	0	-	3.45	0	-	0.9	μs
Minimum Data Preparation Time	t _{SU:DAT}	250	-	-	100	-	-	ns
Rise Time	t _r	-	-	1000	-	-	300	ns
Fall Time	t _f	-	-	300	-	-	300	ns
Minimum Stop Preparation Waiting Time	t _{SU:STO}	4.0	-	-	0.6	-	-	μs
Data Change Minimum Waiting Time	t _{BUF}	4.7	-	-	1.3	-	-	μs
Capacitive load for each bus line	C _b	-	-	400	-	-	400	pF
Noise Margin at the Low Level	V _{nL}	0.5	-	-	0.5	-	-	V
Noise Margin at the High Level	V _{nH}	1	-	-	1	-	-	V

C_b ; total capacitance of one bus line in pF.

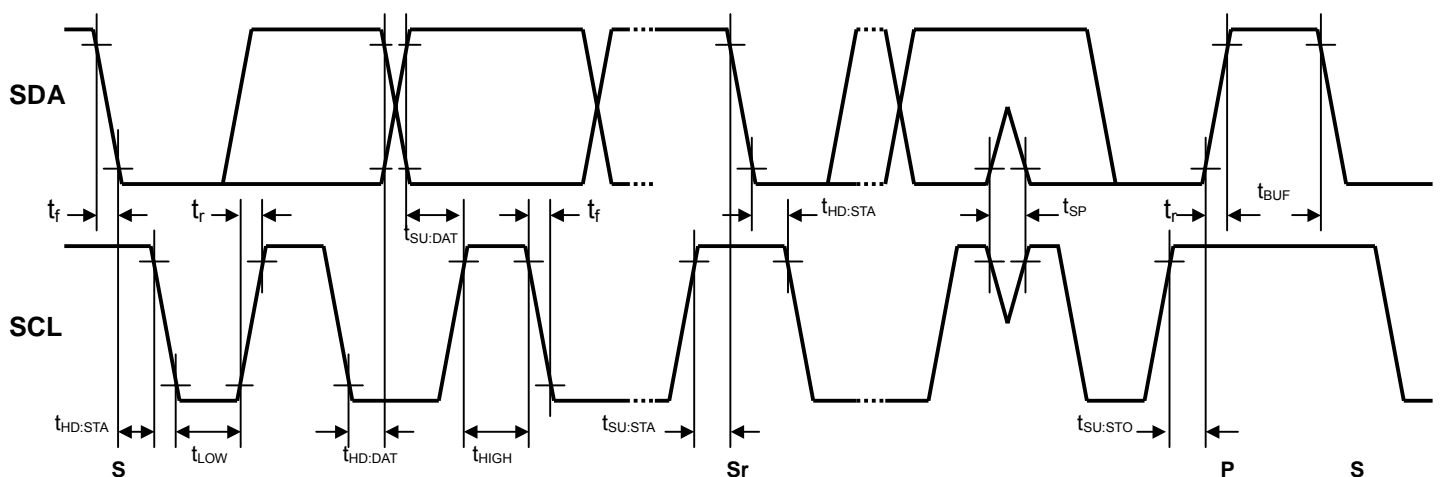

■ DEFINITION OF I²C REGISTER

◆ I²C BUS FORMAT

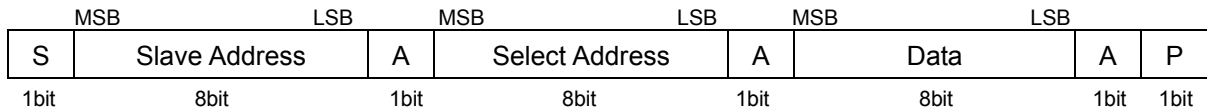

S: Starting Term
 A: Acknowledge Bit
 P: Ending Term

◆ SLAVE ADDRESS

Slave Address								Hex
MSB							LSB	-
1	0	0	0	0	0	0	0	80(h)

◆ CONTROL REGISTER TABLE

The select address sets each function (Volume, Balance, Tone Control, Surround, Voice Enhancement, Input Selector).
 The auto increment function cycles the select address as follows.

00H→01H→02H→03H→00H

<Write Mode>

Select Address	BIT							
	D7	D6	D5	D4	D3	D2	D1	D0
00H	VOL							
01H	CHS	BAL				SUR		
02H	BCB	BASS			VE		*	
03H	BCT	TREB			SEL			

* : Don't Care

◆ CONTROL REGISTER DEFAULT VALUE

Control register default value is all "0".

Select Address	BIT							
	D7	D6	D5	D4	D3	D2	D1	D0
00H	0	0	0	0	0	0	0	0
01H	0	0	0	0	0	0	0	0
02H	0	0	0	0	0	0	0	0
03H	0	0	0	0	0	0	0	0

■ INSTRUCTION CODE

a) MASTER VOLUME SETTING

Select Address	BIT							
	D7	D6	D5	D4	D3	D2	D1	D0
00H	VOL							

- VOL Attenuation Level setting (0.33dB / step)

The volume control for both Ach and Bch(0.33dB/step).

The volume is consisted of volume1 and volume2 and the level is divided into half to each volume1 and volume2.

b) BALANCE, SURROUND SETTING

Select Address	BIT							
	D7	D6	D5	D4	D3	D2	D1	D0
01H	CHS	BAL					SUR	

- CHS : Channel select for balance control

“0” : Ach “Bch is attenuated”

“1” : Bch “Ach is attenuated”

- BAL : Balance control for both Ach and Bch (1dB/step)

The balance is consisted of volume1 and volume2.

<SUR : Surround Level Setting>

Surround Setting	D1	D0	Remarks
Bypass	0	0	Bypass
Simulated Stereo	0	1	Simulated Stereo
eala Effect1	1	0	Surround Effect Low(10dB typ.)
eala Effect2	1	1	Surround Effect High(16dB typ.)

c) TONE CONTROL BASS, VOICE ENHANCEMENT SETTING

Select Address	BIT							
	D7	D6	D5	D4	D3	D2	D1	D0
03H	BCB	BASS				VE		Don't Care

- BCB : Boost cut select for Bass control

“0” : Cut

“1” : Boost

- BASS : BASS Level Setting

Cut Level : -15 to 0dB(1dB/Step)

Boost Level : 0 to +15dB(1dB/Step)

<VE : Voice Enhancement Setting>

VE Setting	D2	D1	Remarks
By-Pass	0	0	Bypass
VE Effect 1	0	1	Voice Enhancement Effect Low (6dB typ.)
VE Effect 2	1	0	Voice Enhancement Effect Mid (10dB typ.)
VE Effect 3	1	1	Voice Enhancement Effect High (13dB typ.)

Note) Surround, Voice Enhancement mode switch settings

The click noise may be generated by changing the Surround, the Voice Enhancement mode.

Provide the external circuit for avoiding the click noise on above condition.

d) TONE CONTROL TREBLE, INPUT SELECTOR SETTING

Select Address	BIT							
	D7	D6	D5	D4	D3	D2	D1	D0
04H	BCT	TREB				SEL		

•BCT : Boost cut select for Treble control

“0” : Cut

“1” : Boost

•TREB : TREBLE Level Setting

Cut Level : -15 to 0dB(1dB/Step)

Boost Level : 0 to +15dB(1dB/Step)

<SEL : Input Selector Setting>

SEL Setting	D2	D1	D0
Input 1	0	0	0
Input 2	0	0	1
Input 3	0	1	0
Input 4	0	1	1
Input5	1	0	0
Input6	1	0	1

■MASTER VOLUME (Select Address : 00H)

		VOL							
Gain (dB)	HEX	D7	D6	D5	D4	D3	D2	D1	D0
0	FF	1	1	1	1	1	1	1	1
-1	FC	1	1	1	1	1	1	0	0
-2	F9	1	1	1	1	1	0	0	1
-3	F6	1	1	1	1	0	1	1	0
-4	F3	1	1	1	1	0	0	1	1
-5	F0	1	1	1	1	0	0	0	0
-6	ED	1	1	1	0	1	1	0	1
-7	EA	1	1	1	0	1	0	1	0
-8	E7	1	1	1	0	0	1	1	1
-9	E4	1	1	1	0	0	1	0	0
-10	E1	1	1	1	0	0	0	0	1
-11	DE	1	1	0	1	1	1	1	0
-12	DB	1	1	0	1	1	0	1	1
-13	D8	1	1	0	1	1	0	0	0
-14	D5	1	1	0	1	0	1	0	1
-15	D2	1	1	0	1	0	0	1	0
-16	CF	1	1	0	0	1	1	1	1
-17	CC	1	1	0	0	1	1	0	0
-18	C9	1	1	0	0	1	0	0	1
-19	C6	1	1	0	0	0	1	1	0
-20	C3	1	1	0	0	0	0	1	1
-21	C0	1	1	0	0	0	0	0	0
-22	BD	1	0	1	1	1	1	0	1
-23	BA	1	0	1	1	1	0	1	0
-24	B7	1	0	1	1	0	1	1	1
-25	B4	1	0	1	1	0	1	0	0
-26	B1	1	0	1	1	0	0	0	1
-27	AE	1	0	1	0	1	1	1	0
-28	AB	1	0	1	0	1	0	1	1
-29	A8	1	0	1	0	1	0	0	0
-30	A5	1	0	1	0	0	1	0	1
-31	A2	1	0	1	0	0	0	1	0
-32	9F	1	0	0	1	1	1	1	1
-33	9C	1	0	0	1	1	1	0	0
-34	99	1	0	0	1	1	0	0	1
-35	96	1	0	0	1	0	1	1	0
-36	93	1	0	0	1	0	0	1	1
-37	90	1	0	0	1	0	0	0	0
-38	8D	1	0	0	0	1	1	0	1
-39	8A	1	0	0	0	1	0	1	0
-40	87	1	0	0	0	0	1	1	1
-41	84	1	0	0	0	0	1	0	0
-42	81	1	0	0	0	0	0	0	1

■MASTER VOLUME (Select Address : 00H)

		VOL							
Gain (dB)	HEX	D7	D6	D5	D4	D3	D2	D1	D0
-43	7E	0	1	1	1	1	1	1	0
-44	7B	0	1	1	1	1	0	1	1
-45	78	0	1	1	1	1	0	0	0
-46	75	0	1	1	1	0	1	0	1
-47	72	0	1	1	1	0	0	1	0
-48	6F	0	1	1	0	1	1	1	1
-49	6C	0	1	1	0	1	1	0	0
-50	69	0	1	1	0	1	0	0	1
-51	66	0	1	1	0	0	1	1	0
-52	63	0	1	1	0	0	0	1	1
-53	60	0	1	1	0	0	0	0	0
-54	5D	0	1	0	1	1	1	0	1
-55	5A	0	1	0	1	1	0	1	0
-56	57	0	1	0	1	0	1	1	1
-57	54	0	1	0	1	0	1	0	0
-58	51	0	1	0	1	0	0	0	1
-59	4E	0	1	0	0	1	1	1	0
-60	4B	0	1	0	0	1	0	1	1
-61	48	0	1	0	0	1	0	0	0
-62	45	0	1	0	0	0	1	0	1
-63	42	0	1	0	0	0	0	1	0
-64	3F	0	0	1	1	1	1	1	1
-65	3C	0	0	1	1	1	1	0	0
-66	39	0	0	1	1	1	0	0	1
-67	36	0	0	1	1	0	1	1	0
-68	33	0	0	1	1	0	0	1	1
-69	30	0	0	1	1	0	0	0	0
-70	2D	0	0	1	0	1	1	0	1
-71	2A	0	0	1	0	1	0	1	0
-72	27	0	0	1	0	0	1	1	1
-73	24	0	0	1	0	0	1	0	0
-74	21	0	0	1	0	0	0	0	1
-75	1E	0	0	0	1	1	1	1	0
-76	1B	0	0	0	1	1	0	1	1
-77	18	0	0	0	1	1	0	0	0
-78	15	0	0	0	1	0	1	0	1
-79	12	0	0	0	1	0	0	1	0
-80	0F	0	0	0	0	1	1	1	1
-81	0C	0	0	0	0	1	1	0	0
-82	09	0	0	0	0	1	0	0	1
-83	06	0	0	0	0	0	1	1	0
-84	03	0	0	0	0	0	0	1	1
Mute*	00	0	0	0	0	0	0	0	0

* : Default Value

■BALANCE (Select Address : 01H)

Channel Select (CHS)	D7
Ach(Bch is attenuate)	0
Bch(Ach is attenuate)	1

Gain(dB)	BAL				
	D6	D5	D4	D3	D2
0*	0	0	0	0	0
-1	0	0	0	0	1
-2	0	0	0	1	0
-3	0	0	0	1	1
-4	0	0	1	0	0
-5	0	0	1	0	1
-6	0	0	1	1	0
-7	0	0	1	1	1
-8	0	1	0	0	0
-9	0	1	0	0	1
-10	0	1	0	1	0
-11	0	1	0	1	1
-12	0	1	1	0	0
-13	0	1	1	0	1
-14	0	1	1	1	0
-15	0	1	1	1	1
-16	1	0	0	0	0
-17	1	0	0	0	1
-18	1	0	0	1	0
-19	1	0	0	1	1
-20	1	0	1	0	0
-21	1	0	1	0	1
-22	1	0	1	1	0
-23	1	0	1	1	1
-24	1	1	0	0	0
-25	1	1	0	0	1
-26	1	1	0	1	0
-27	1	1	0	1	1
-28	1	1	1	0	0
-29	1	1	1	0	1
-30	1	1	1	1	0
Mute	1	1	1	1	1

* : Default Value

■Tone Control(Bass Setting) (Select Address : 02H)

Bass Cut or Boost	BCB
	D7
Cut*	0
Boost	1

Cut Gain(dB) / Boost Gain(dB)		BASS			
		D6	D5	D4	D3
-15	15	1	1	1	1
-14	14	1	1	1	0
-13	13	1	1	0	1
-12	12	1	1	0	0
-11	11	1	0	1	1
-10	10	1	0	1	0
-9	9	1	0	0	1
-8	8	1	0	0	0
-7	7	0	1	1	1
-6	6	0	1	1	0
-5	5	0	1	0	1
-4	4	0	1	0	0
-3	3	0	0	1	1
-2	2	0	0	1	0
-1	1	0	0	0	1
0*	0	0	0	0	0

* : Default value

TONE CONTROL TREBLE (Select Address : 03H)

Treble Cut or Boost	BCT
	D7
Cut*	0
Boost	1

		TREB			
		D6	D5	D4	D3
Cut Gain(dB)	Boost Gain(dB)				
-15	15	1	1	1	1
-14	14	1	1	1	0
-13	13	1	1	0	1
-12	12	1	1	0	0
-11	11	1	0	1	1
-10	10	1	0	1	0
-9	9	1	0	0	1
-8	8	1	0	0	0
-7	7	0	1	1	1
-6	6	0	1	1	0
-5	5	0	1	0	1
-4	4	0	1	0	0
-3	3	0	0	1	1
-2	2	0	0	1	0
-1	1	0	0	0	1
0*	0	0	0	0	0

* : Default value

[CAUTION]

The specifications on this databook are only given for information , without any guarantee as regards either mistakes or omissions. The application circuits in this databook are described only to show representative usages of the product and not intended for the guarantee or permission of any right including the industrial rights.