

4-Channel Electronic Volume with Input Selector

■ GENERAL DESCRIPTION

The NJW1195 is a 4-channel electronic volume with 4-in 2-out stereo audio selector. It performs low noise and low distortion characteristics with resistance ladder circuit.

The NJW1195 is also available for 2-channel differential transmission electronic volume with 2-in 1-out stereo audio selector by a differential transmission select function.

All of functions are controlled via three-wired serial bus. Selectable 4-Chip address is available for using four chips on same serial bus line.

It's suitable for two-channel stereo system and or multi-channel audio system.

■ PACKAGE OUTLINE



NJW1195V

■ FEATURES

- Operating Voltage ±4.5 to ±7.5V
- 3-Wired Serial Control Chip Address Select Function
- Selectable 4-Chip Address Available for using four chips on same serial bus line
- Low Output Noise -118dBV typ.
- Low Distortion 0.0003% typ. at Vin=1Vrms (Differential transmission)
- 4in 2out Stereo Signal Selector +31.5 to -95dB / 0.5dB step, Mute
- Volume -120dB typ.
- Differential transmission select function
- Channel Separation
- Zero Cross Detection
- Bi-CMOS Technology
- Package Outline SSOP32

■ BLOCK DIAGRAM

Application example 1

4-channel electronic volume with 4-in 2-out stereo audio selector (DIFF pin = Low)

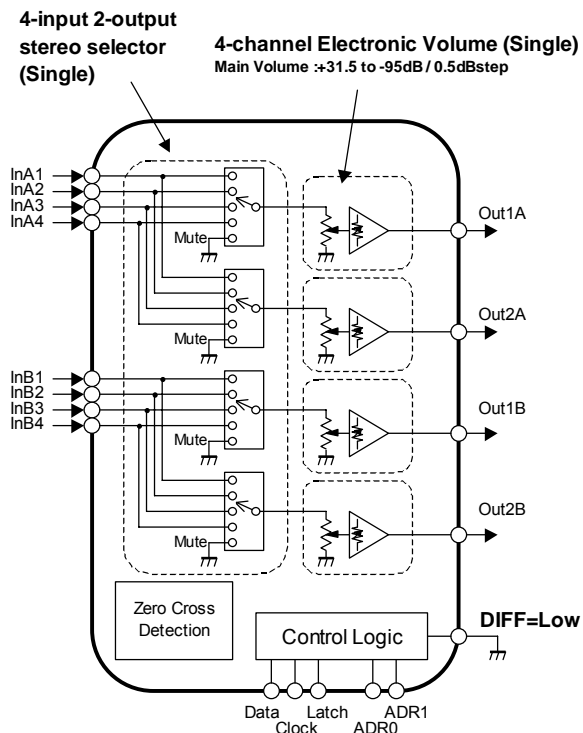

Application example 2

2-channel differential transmission electronic volume with 2-in 1-out stereo audio selector (DIFF pin = High)

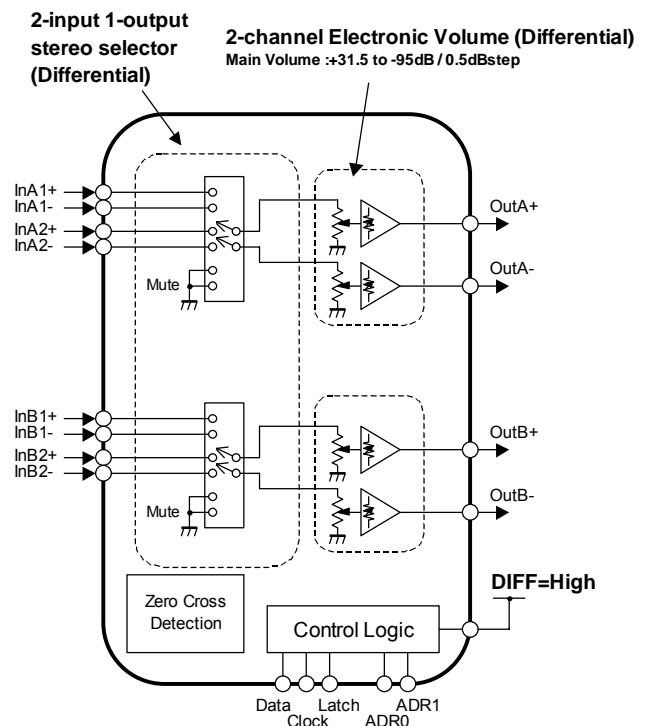

■ ABSOLUTE MAXIMUM RATING (Ta=25°C)

PARAMETER	SYMBOL	RATING	UNIT
Power Supply Voltage	V _{+/-}	+8/-8	V
Maximum Input Voltage	V _{IM}	V _{+/-}	V
Power Dissipation	P _D	800 <small>NOTE: EIA/JEDEC STANDARD Test board (76.2x114.3x1.6mm, 2layer, FR-4) mounting</small>	mW
Operating Temperature Range	Topr	-40 ~ +85	°C
Storage Temperature Range	Tstg	-40 ~ +125	°C

■ ELECTRICAL CHARACTERISTICS (Ta=25°C, V_{+/-}=±7V, R_L=47kΩ, Volume=0dB)

PARAMETER	SYMBOL	TEST CONDITION	MIN.	TYP.	MAX.	UNIT
◆ Power Supply						
Operating Voltage	V _{+/-}		± 4.5	± 7.0	± 7.5	V
Supply Current 1	I _{CC}	No signal	-	9	15	mA
Supply Current 2	I _{EE}	No signal	-	9	15	mA
◆ Input/Output Characteristics (Output)						
Maximum Output Voltage	V _{OM}	f=1kHz, THD=1% Volume=0dB	3.6	4.2	-	Vrms
Voltage Gain 1	G _{V1}	V _{IN} =2Vrms, f=1kHz Volume=0dB	-0.5	0	0.5	dB
Voltage Gain 2	G _{V2}	V _{IN} =100mVrms, f=1kHz Volume=+15dB	+14	+15	+16	dB
Voltage Gain Error 1	ΔG _{V1}	V _{IN} =2Vrms, f=1kHz Volume=0dB	-0.5	0	0.5	dB
Voltage Gain Error 2	ΔG _{V2}	V _{IN} =2Vrms, f=1kHz Volume=-60dB	-1.0	0	1.0	dB
Maximum Attenuation	A _{TT}	f=1kHz, V _{IN} =2Vrms Volume=-95dB, A-weight	-	-95	-	dB
Mute level	Mute	f=1kHz, V _{IN} =2Vrms Volume=Mute, A-weight	-	-120	-	dB
Cross Talk 1	CT1	f=1kHz, V _{IN} =2Vrms, A-weight Volume=0dB, R _g =0Ω	-	-115	-	dB
Cross Talk 2	CT2	f=20kHz, V _{IN} =2Vrms, Volume=0dB, R _g =0Ω	-	-95	-	dB
Channel Separation 1	CS1	f=1kHz, V _{IN} =2Vrms, A-weight Volume=0dB, R _g =0Ω Out1 vs. Out2	-	-120	-90	dB
Channel Separation 2	CS2	f=20kHz, V _{IN} =2Vrms, Volume=0dB, R _g =0Ω Out1 vs. Out2	-	-100	-	dB
Channel Separation 3	CS3	f=1kHz, V _{IN} =2Vrms, A-weight Volume=0dB, R _g =0Ω OutA vs. OutB	-	-120	-90	dB
Channel Separation 4	CS4	f=20kHz, V _{IN} =2Vrms, Volume=0dB, R _g =0Ω OutA vs. OutB	-	-100	-	dB
Input Impedance *	R _{IN}	Select Channel Input Terminal	15	20	-	kΩ

* Input Impedance is reduced by half (10kΩ typ.) when input selector 1 (SEL1) and input selector 2 (SEL2) chose the same input.

■ ELECTRICAL CHARACTERISTICS (Ta=25°C, V⁺/V⁻=±7V, RL=47kΩ, Volume=0dB)

PARAMETER	SYMBOL	TEST CONDITION	MIN.	TYP.	MAX.	UNIT
◆ Input/Output Characteristics (Output)						
Output Noise1	V _{NO1}	Volume=0dB, Rg=0, A-weight	-	-118 (1.26μ)	-100 (10μ)	dBV (Vrms)
Output Noise2	V _{NO2}	Volume=-95dB, Rg=0, A-weight	-	-118 (1.26μ)	-	dBV (Vrms)
Total Harmonic Distortion 1	T.H.D.1	f=1kHz, V _{IN} =200mVrms, VOL=0dB, BW=400Hz-30kHz	-	0.001	-	%
Total Harmonic Distortion 2	T.H.D.2	f=10kHz, V _{IN} =200mVrms, VOL=0dB, BW=400Hz-30kHz	-	0.0015	-	%
Total Harmonic Distortion 3	T.H.D.3	f=1kHz, V _{IN} =2Vrms, VOL=0dB, BW=400Hz-30kHz	-	0.0007	-	%
Total Harmonic Distortion 4	T.H.D.4	f=10kHz, V _{IN} =2Vrms, VOL=0dB, BW=400Hz-30kHz	-	0.001	-	%
Total Harmonic Distortion 5	T.H.D.5	f=1kHz, V _{IN} =200mVrms, VOL=+15dB, BW=400Hz-30kHz	-	0.001	-	%
Total Harmonic Distortion 6	T.H.D.6	f=10kHz, V _{IN} =200mVrms, VOL=+15dB, BW=400Hz-30kHz	-	0.0015	-	%
Total Harmonic Distortion 7	T.H.D.7	f=1kHz, V _{IN} =2Vrms, VOL=-18dB, BW=400Hz-30kHz	-	0.0015	0.02	%
Total Harmonic Distortion 8	T.H.D.8	f=10kHz, V _{IN} =2Vrms, VOL=-18dB, BW=400Hz-30kHz	-	0.0015	-	%
Total Harmonic Distortion 9	T.H.D.9	f=1kHz, V _{IN} =1Vrms, VOL=0dB, BW=400Hz-30kHz, Differential transmission	-	0.0003	-	%
Total Harmonic Distortion 10	T.H.D.10	f=10kHz, V _{IN} =1Vrms, VOL=0dB, BW=400Hz-30kHz, Differential transmission	-	0.0003	-	%
◆ Logic Control Characteristics						
High Level Input Voltage	V _{IH}	DATA, CLOCK, LATCH, ADR0, ADR1, DIFF Terminal Input	2.5	-	V ⁺	V
Low Level Input Voltage	V _{IL}	DATA, CLOCK, LATCH, ADR0, ADR1, DIFF Terminal Input	0	-	1.5	V

[CAUTION]
The specifications on this databook are only given for information, without any guarantee as regards either mistakes or omissions. The application circuits in this databook are described only to show representative usages of the product and not intended for the guarantee or permission of any right including the industrial rights.