

2ch Electronic Volume with Dynamic Bass Boost

■ GENERAL DESCRIPTION

The NJW1201A is a 2-channel electronic volume with Dynamic Bass Boost. 5+1diff-in 1-out selector. It includes 5+1diff input selector, 1st-volume, 2nd-volume, 3 band Tone, Sound mode, Dynamic Bass Boost. The NJW1201A performs low noise and low distortion characteristics with resistance ladder circuit.

All of functions are controlled by I²C BUS interface.

■ PACKAGE OUTLINE

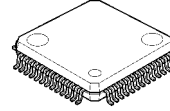

NJW1201AFH2

■ FEATURES

- Operating Voltage +7.5 to +10V
- I²C BUS Control
- Low output noise -110dBVtyp.
- Low THD 0.01%typ.
- 5+1diff Input Selector
- Input Gain 0 to +30dB/2dBstep
- 1st-Volume 0 to -62dB / 1dBstep, MUTE
- 2nd-Volume 0 to -28dB / 2dBstep, MUTE
- 3 Band Tone 0 to ±14dB/ 2dBstep (Treble,Middle), 0 to ±17.5dB/ 2.5dBstep (Bass)
- Sound mode 3 modes (eala, ealaTreble, eala & ealaTreble)
- Sound Gain 2-level Gains
- Dynamic Bass Boost 3-level Gains
- Bi-CMOS Technology
- Package Outline LQFP52-H2

■ BLOCK DIAGRAM

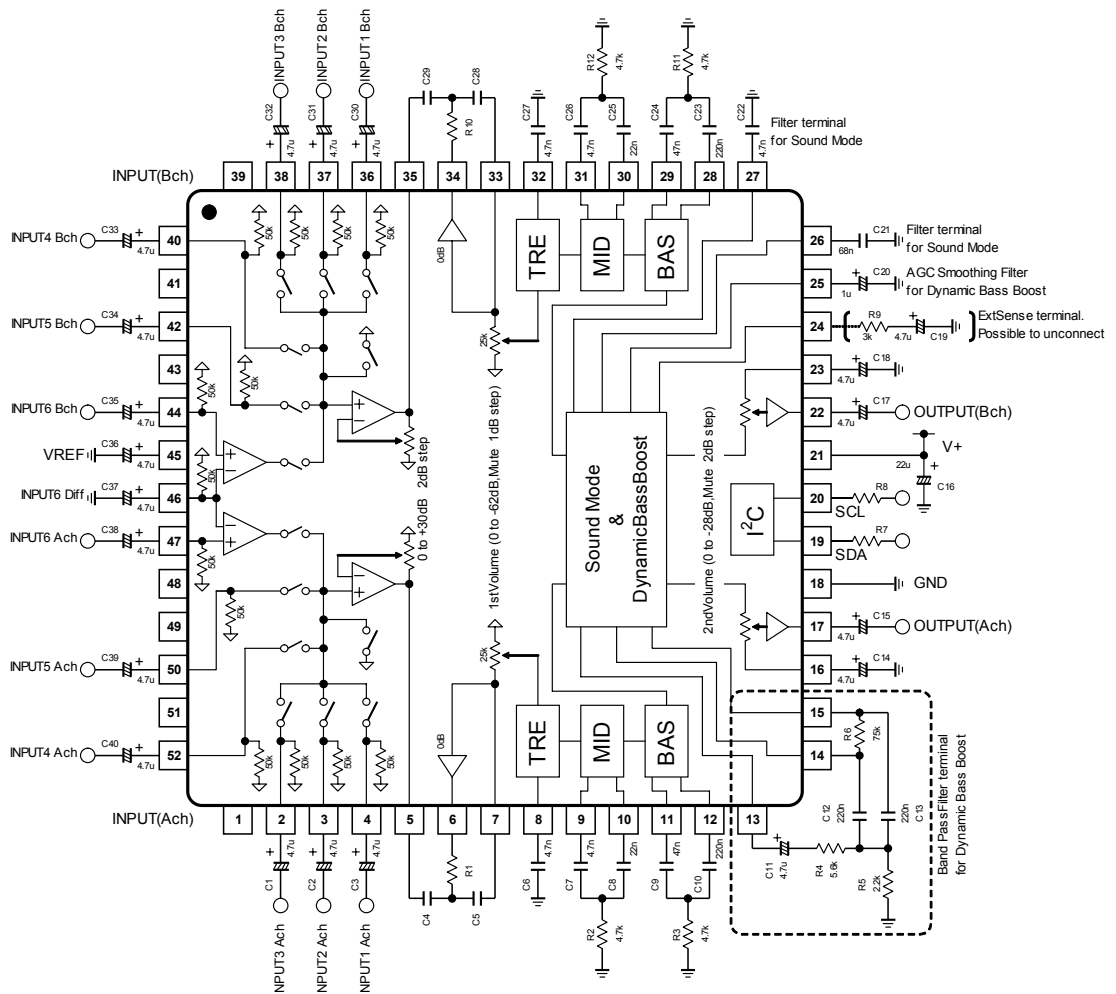

NJW1201A

■PIN CONFIGURATION

LQFP52

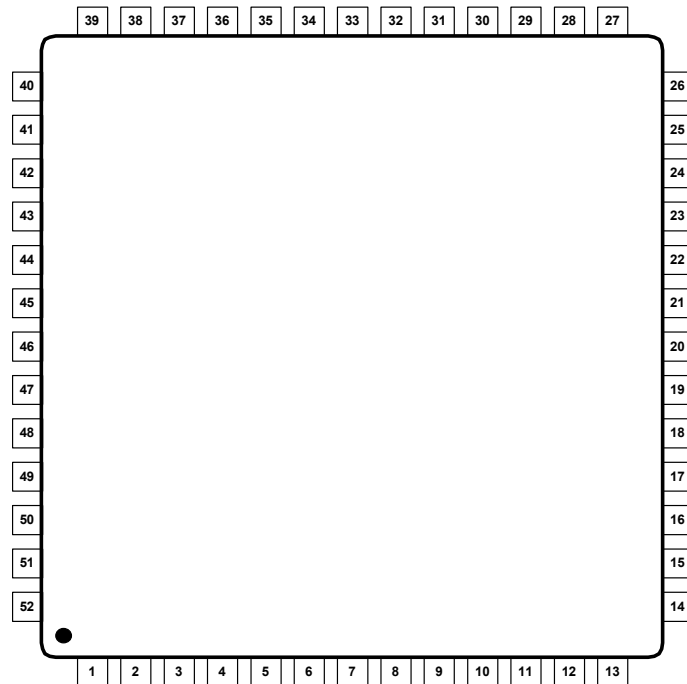

No.	Symbol	Function	No	Symbol	Function
1	NC	Not Connected	27	SRFil	Filter for Sound Mode
2	In3A	Ach Input3	28	TONEB2B	Bch Bass(Tone) Filter 1
3	IN2A	Ach Input2	29	TONEB1B	Bch Bass(Tone) Filter 2
4	In1A	Ach Input1	30	TONEM2B	Bch Middle(Tone) Filter 1
5	MonOutA	Ach Monitor Output	31	TONEM1B	Bch Middle(Tone) Filter 2
6	RecOutA	Ach Rec Output	32	TONEHB	Bch Treble(Tone) Filter
7	VOLInA	Ach 1 st Volume Input	33	VOLInB	Bch 1 st Volume Input
8	TONEHA	Ach Treble(Tone) Filter	34	RecOutB	Bch Rec Output
9	TONEM1A	Ach Middle(Tone) Filter 1	35	MonOutB	Bch Monitor Output
10	TONEM2A	Ach Middle(Tone) Filter 2	36	In1B	Bch Input1
11	TONEB1A	Ach Bass(Tone) Filter 1	37	IN2B	Bch Input2
12	TONEB2A	Ach Bass(Tone) Filter 2	38	IN3B	Bch Input3
13	BPF1	Filter 1 for DBB	39	NC	Not Connected
14	BPF2	Filter 2 for DBB	40	IN4B	Bch Input4
15	BPF3	Filter 3 for DBB	41	NC	Not Connected
16	VOL2CAPA	Ach DC coupling for 2 nd Volume	42	IN5B	Bch Input5
17	OutA	Ach Output	43	NC	Not Connected
18	GND	Ground	44	IN6B	Bch Input6
19	SDA	I2C DATA	45	VREF	Reference Voltage
20	SCL	I2C CLOCK	46	In6Diff	Negative Input for Input6
21	V+	Supply Voltage	47	In6A	Ach Input6
22	OutB	Bch Output	48	NC	Not Connected
23	VOL2CAPB	Bch 2 nd Volume DC coupling	49	NC	Not Connected
24	ExtSense	AGC Boost Level for DBB	50	In5A	Ach Input5
25	INT	AGC Smoothing Filter for DBB	51	NC	Not Connected
26	SurTC	Filter for Sound Mode	52	In4A	Ach Input4

■ **ABSOLUTE MAXIMUM RATING** (Ta=25°C)

PARAMETER	SYMBOL	RATING	UNIT
Power Supply Voltage	V ₊	10.5	V
Power Dissipation	P _D	1200 (Note1)	mW
Maximum Input Voltage	V _{IMAX}	0 ~ V ₊ (Note2)	V
Operating Temperature Range	Topr	-20 ~ +75	°C
Storage Temperature Range	Tstg	-40 ~ +125	°C

(Note1) EIA/JEDEC STANDARD Test board (76.2x114.3x1.6mm, 2layer, FR-4) mounting

(Note2) Don't put Input Voltage more than Power Supply Voltage.

■ **ELECTRICAL CHARACTERISTICS**

(Ta=25°C, V⁺=9V, Rg=0Ω, RL=47kΩ, Vin=1Vrms, f=1kHz, 1stVOL=0dB, all controls flat unless otherwise specified)

PARAMETER	SYMBOL	TEST CONDITION	MIN.	TYP.	MAX.	UNIT
Operating Voltage	V ₊		7.5	9.0	10.0	V
Supply Current	I _{DD}	No signal	-	12	18	mA
Reference Voltage	V _{REF}	No signal	4.0	4.5	5.0	V
Volume Input Resistance	R _{INVOL}	No signal	-	26.5	-	kΩ
Maximum Input Voltage	V _{IM}	1st Volume=-20dB THD=1%	2.0	2.4	-	Vrms
Maximum Output Voltage	V _{OM}	THD=1%	2.0	2.4	-	Vrms
Maximum Input Gain	G _{VINMAX}	Input Gain=+30dB Vin=50mVrms	-	30	-	dB
Maximum Gain	G _{VMAX}		-1	0	1	dB
Mute Level	Mute	1st Volume = Mute 2nd Volume = Mute	-	-100	-90	dB
Channel Balance	G _{CB}		-1	0	1	dB
Total Harmonic Distortion	THD+N	V _O =0.5Vrms, BW=400Hz-30kHz	-	0.01	0.05	%
Output Noise Voltage 1	V _{NO1}	Rg=0Ω, Filter : A-Weighted	-	-100 (10)	-94 (20)	dBV (uVrms)
Output Noise Voltage 2	V _{NO2}	1st Volume = Mute 2nd Volume=Mute Rg=0Ω, Filter : A-Weighted	-	-110 (3)	-100 (10)	dBV (uVrms)
Cross Talk	CT	Selected Input : Rg=0Ω Unselected Input : Signal	-	-	-80	dB
Channel Separation	CS	Rg=0Ω	-	-	-80	dB

◆ **Tone Control**

(Ta=25°C, V⁺=9V, Rg=0Ω, RL=47kΩ, Vin=0.1Vrms, f=1kHz, all controls flat unless otherwise specified)

PARAMETER	SYMBOL	TEST CONDITION	MIN.	TYP.	MAX.	UNIT
High Frequency Boost	HF _{BST}	TREB="1111", f=10kHz	11.5	14.0	16.5	dB
High Frequency Cut	HF _{CUT}	TREB="0111", f=10kHz	-16.5	-14.0	-11.5	dB
Mid Frequency Boost	MF _{BST}	MIDD="1111", f=1kHz	11.5	14.0	16.5	dB
Mid Frequency Cut	MF _{CUT}	MIDD="0111", f=1kHz	-16.5	-14.0	-11.5	dB
Low Frequency Boost	LF _{BST}	BASS="1111", f=100Hz	15.0	17.5	20.0	dB
Low Frequency Cut	LF _{CUT}	BASS="0111", f=100Hz	-20.0	-17.5	-15.0	dB

◆ Sound mode Characteristics

(Ta=25°C, V⁺=9V, Rg=0Ω, RL=47kΩ, Vin=0.1Vrms, f=1kHz, all controls flat unless otherwise specified)

PARAMETER	SYMBOL	TEST CONDITION	MIN.	TYP.	MAX.	UNIT
SOUND MODE 1	G _{Vm1}	SOUNDMODE="01" Ain-Aout, f=10kHz	-	4.0	-	dB
SOUND MODE 2	G _{Vm2}	SOUNDMODE="10" Ain-Aout,	-	4.0	-	dB
SOUND MODE 3	G _{Vm3}	SOUNDMODE="11" Ain-Aout	-	4.5	-	dB

◆ Sound Gain Characteristics

(Ta=25°C, V⁺=9V, Rg=0Ω, RL=47kΩ, Vin=0.1Vrms, f=1kHz, all controls flat unless otherwise specified)

PARAMETER	SYMBOL	TEST CONDITION	MIN.	TYP.	MAX.	UNIT
SOUND GAIN 1	G _{Vs1}	SOUNDGAIN ="0" SOUNDMODE="10" Ain-Aout,	-	4.0	-	dB
SOUND GAIN 2	G _{Vs2}	SOUNDGAIN ="1" SOUNDMODE="10" Ain-Aout,	-	6.5	-	dB

◆ Dynamic Bass Boost Characteristics

(Ta=25°C, V⁺=9V, Rg=0Ω, RL=47kΩ, Vin=0.05Vrms, f=1kHz, all controls flat unless otherwise specified)

PARAMETER	SYMBOL	TEST CONDITION	MIN.	TYP.	MAX.	UNIT
DBB Gain 1	G _{VsDBB1}	DBBGain="01", (A+B)in-Aout	-	7.5	-	dB
DBB Gain 2	G _{VsDBB2}	DBBGain="10", (A+B)in-Aout	-	10.5	-	dB
DBB Gain 3	G _{VsDBB3}	DBBGain="11", (A+B)in-Aout	-	14.0	-	dB

■TIMING ON THE I²C BUS (SDA,SCL)

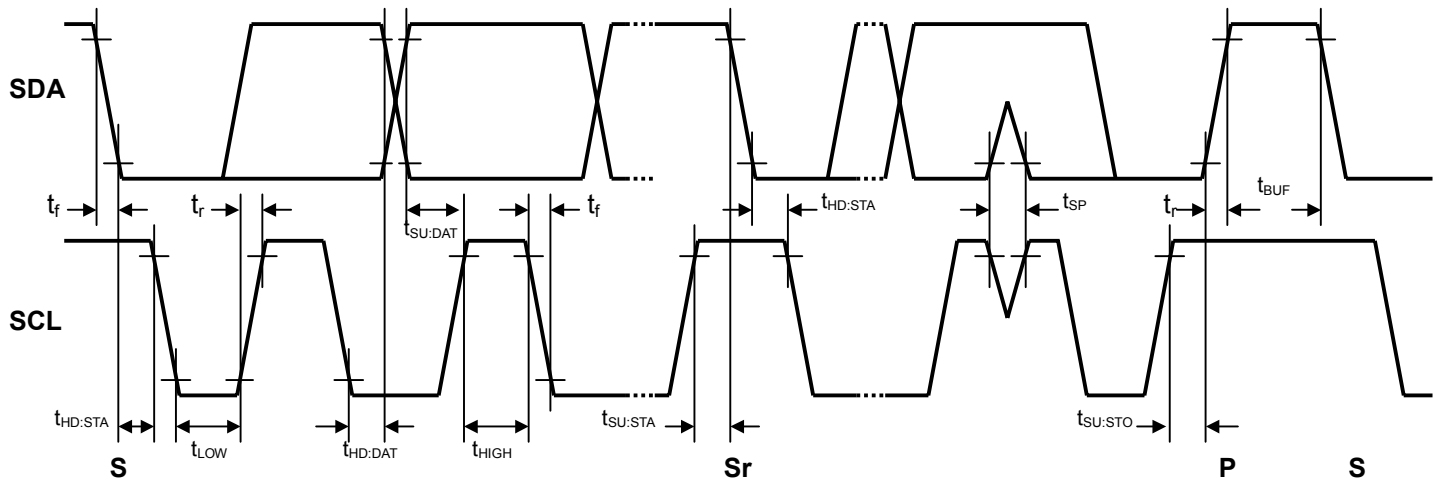

■CHARACTERISTICS OF I/O STAGES FOR I²C BUS (SDA,SCL)

I²C BUS Load Conditions

STANDARD MODE : Pull up resistance 4kΩ (Connected to +5V), Load capacitance 200pF (Connected to GND)

FAST MODE : Pull up resistance 4kΩ (Connected to +5V), Load capacitance 50pF (Connected to GND)

PARAMETER	SYMBOL	Standard mode			Fast mode			UNIT
		MIN.	TYP.	MAX.	MIN.	TYP.	MAX.	
Low Level Input Voltage	V_{IL}	0.0	-	1.5	0.0	-	1.5	V
High Level Input Voltage	V_{IH}	2.7	-	5.0	2.7	-	5.0	V
Low level output voltage (3mA at SDA pin)	V_{OL}	0	-	0.4	0	-	0.4	V
Input current each I/O pin with an input voltage between 0.1V _{DD} and 0.9V _{DDmax}	I_i	-10	-	10	-10	-	10	μA

NJW1201A

■CHARACTERISTICS OF BUS LINES (SDA,SCL) FOR I²C-BUS DEVICES

PARAMETER	SYMBOL	Standard mode			Fast mode			UNIT
		MIN.	TYP.	MAX.	MIN.	TYP.	MAX.	
SCL clock frequency	f _{SCL}	-	-	100	-	-	400	kHz
Hold time (repeated) START condition.	t _{HD:STA}	4.0	-	-	0.6	-	-	μs
Low period of the SCL clock	t _{LOW}	4.7	-	-	1.3	-	-	μs
High period of the SCL clock	t _{HIGH}	4.0	-	-	0.6	-	-	μs
Set-up time for a repeated START condition	t _{SU:STA}	4.7	-	-	0.6	-	-	μs
Data hold time ^(NOTE)	t _{HD:DAT}	0	-	-	0	-	-	μs
Data set-up time	t _{SU:DAT}	250	-	-	100	-	-	ns
Rise time of both SDA and SCL signals	t _r	-	-	1000	-	-	300	ns
Fall time of both SDA and SCL signals	t _f	-	-	300	-	-	300	ns
Set-up time for STOP condition	t _{SU:STO}	4.0	-	-	0.6	-	-	μs
Bus free time between a STOP and START condition	t _{BUF}	4.7	-	-	1.3	-	-	μs
Capacitive load for each bus line	C _b	-	-	400	-	-	400	pF
Noise margin at the Low level	V _{nL}	0.5	-	-	0.5	-	-	V
Noise margin at the High level	V _{nH}	1	-	-	1	-	-	V

C_b ; total capacitance of one bus line in pF.

NOTE). Data hold time : t_{HD:DAT}

Please hold the Data Hold Time (t_{HD:DAT}) to 300ns or more to avoid status of unstable at SCL falling edge.

The SDA block in the NJW1201A does not hold data. Add external data-delay-circuit of the SDA terminal, in case of not providing a hold time of at least 300nsec for the SDA in the master device.

The time-consists of the data-delay-circuit of the SDA terminal are as follows.

- (a) Low level → High level : $T_{LH} \approx R_p * C_D$
- (b) High level → Low level : $T_{HL} \approx R_D * C_D$

In addition, Schottky barrier diode (SBD) influences a Low level at the Acknowledge. Therefore choose the low forward voltage (V_f) as much as possible.

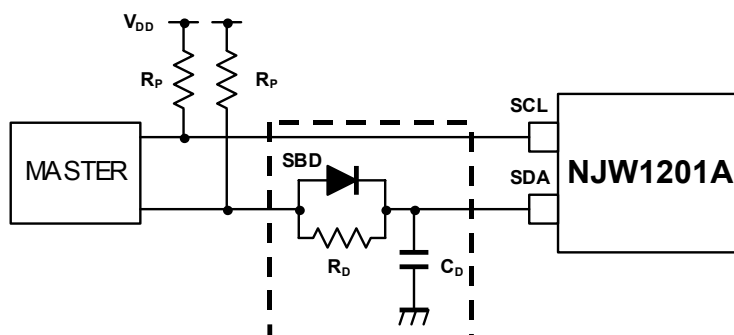

■ DEFINITION OF I²C REGISTER

◆ I²C BUS FORMAT



S: Starting Term
A: Acknowledge Bit
P: Ending Term

◆ SLAVE ADDRESS

Slave Address								Hex
MSB				LSB				-
1	0	0	0	1	0	0	0	88(h)

◆ CONTROL REGISTER TABLE

The select address sets each function (Input Selector, Input Gain, 1st-Volume, Tone Control, 2nd-Volume, ealaSurrond, Dynamic Bass Boost, Other Settings).

The auto increment function cycles the select address as follows.

00H→01H→02H→03H→04H→00H

<Write Mode>

Select Address	BIT							
	D7	D6	D5	D4	D3	D2	D1	D0
00H	*	INPUT SELECTOR			INPUT GAIN (0 to 30dB / 2dBstep)			
01H	*	*	1st-VOL (0 to -55dB / 1dBstep, MUTE)					
02H	TREB (0 to ±14dB/ 2dBstep)				MIDD (0 to ±14dB/ 2dBstep)			
03H	BASS (0 to ±17.5dB/ 2.5dBstep)				2nd-VOL (0 to -28dB / 2dBstep, MUTE)			
04H	*	SOUND GAIN	SOUND MODE (3 modes)		DBB GAIN (3 levels)		DBB SENSE (3 levels)	

* : Don't Care

◆ CONTROL REGISTER DEFAULT VALUE

Control register default value is all "0".

Select Address	BIT							
	D7	D6	D5	D4	D3	D2	D1	D0
00H	0	0	0	0	0	0	0	0
01H	0	0	0	0	0	0	0	0
02H	0	0	0	0	0	0	0	0
03H	0	0	0	0	0	0	0	0
04H	0	0	0	0	0	0	0	0

■INSTRUCTION CODE

a) INPUT SELECTOR, INPUT GAIN SETTING

Select Address	BIT								
	D7	D6	D5	D4	D3	D2	D1	D0	
00H	*	INPUT SELECTOR				INPUT GAIN			

- INPUT SELECTOR : INPUT 1 to 5 (Single Ended), INPUT 6 (Single Ended/Differential), Mute
- INPUT GAIN : 0 to +30 dB (2dB/Step)

b) HI PATH FILTER SWITCH, 1st VOLUME

Select Address	BIT							
	D7	D6	D5	D4	D3	D2	D1	D0
01H	*	*	1 st VOLUME					

- 1st Volume : 0 to -62 dB (1dB/Step) , MUTE

c) TREBLE, MIDDLE

Select Address	BIT							
	D7	D6	D5	D4	D3	D2	D1	D0
02H	TREB				MIDD			

- TREB : 0 to ±14dB/ 2dBstep
- MIDD : 0 to ±14dB/ 2dBstep

d) BASS, 2nd VOLUME

Select Address	BIT							
	D7	D6	D5	D4	D3	D2	D1	D0
03H	BASS				2 nd VOLUME			

- BASS : 0 to ±17.5dB/ 2.5dBstep
- 2nd VOLUME : 0 to -28dB/ 2dBstep , MUTE

e) SOUND ENHANCEMENT, DYNAMIC BASS BOOST

Select Address	BIT							
	D7	D6	D5	D4	D3	D2	D1	D0
04H	*	SOUND GAIN	SOUND MODE		DBB GAIN		DBB SENSE	

- SOUND GAIN : Sound Gain has 2 levels
- SOUND MODE : Sound mode has 3 types
- DBB GAIN : Dynamic Bass Boost Gain has 3 levels
- DBB SENSE : This means detect level of input signal.

■INPUT SELECTOR (Select Address : 00H)

	00H		
	D6	D5	D4
INPUT 1	0	0	0
INPUT 2	0	0	1
INPUT 3	0	1	0
INPUT 4	0	1	1
INPUT 5	1	0	0
INPUT 6 (Single Ended)	1	0	1
INPUT 6 (Differential)	1	1	0
MUTE	1	1	1

*: Default Value

■INPUT GAIN (Select Address : 00H)

Gain(dB)	00H			
	D3	D2	D1	D0
0*	0	0	0	0
+2	0	0	0	1
+4	0	0	1	0
+6	0	0	1	1
+8	0	1	0	0
+10	0	1	0	1
+12	0	1	1	0
+14	0	1	1	1
+16	1	0	0	0
+18	1	0	0	1
+20	1	0	1	0
+22	1	0	1	1
+24	1	1	0	0
+26	1	1	0	1
+28	1	1	1	0
+30	1	1	1	1

*: Default Value

NJW1201A

■1st VOLUME (Select Address : 01H)

Gain (dB)	01H					
	D5	D4	D3	D2	D1	D0
0	1	1	1	1	1	1
-1	1	1	1	1	1	0
-2	1	1	1	1	0	1
-3	1	1	1	1	0	0
-4	1	1	1	0	1	1
-5	1	1	1	0	1	0
-6	1	1	1	0	0	1
-7	1	1	1	0	0	0
-8	1	1	0	1	1	1
...	...					
-16	1	0	1	1	1	1
...	...					
-32	0	1	1	1	1	1
...	...					
-48	0	0	1	1	1	1
...
-56	0	0	0	1	1	1
-57	0	0	0	1	1	0
-58	0	0	0	1	0	1
-59	0	0	0	1	0	0
-60	0	0	0	0	1	1
-61	0	0	0	0	1	0
-62	0	0	0	0	0	1
MUTE	0	0	0	0	0	0

*: Default Value

■TREBLE (Select Address : 02H)

Gain(dB)	02H			
	D7	D6	D5	D4
+14	1	1	1	1
+12	1	1	1	0
+10	1	1	0	1
+8	1	1	0	0
+6	1	0	1	1
+4	1	0	1	0
+2	1	0	0	1
0	1	0	0	0
0*	0	0	0	0
-2	0	0	0	1
-4	0	0	1	0
-6	0	0	1	1
-8	0	1	0	0
-10	0	1	0	1
-12	0	1	1	0
-14	0	1	1	1

*: Default Value

■MIDDLE (Select Address : 02H)

Gain(dB)	02H			
	D3	D2	D1	D0
+14	1	1	1	1
+12	1	1	1	0
+10	1	1	0	1
+8	1	1	0	0
+6	1	0	1	1
+4	1	0	1	0
+2	1	0	0	1
0	1	0	0	0
0*	0	0	0	0
-2	0	0	0	1
-4	0	0	1	0
-6	0	0	1	1
-8	0	1	0	0
-10	0	1	0	1
-12	0	1	1	0
-14	0	1	1	1

*: Default Value

■BASS (Select Address : 03H)

Gain(dB)	03H			
	D7	D6	D5	D4
+17.5	1	1	1	1
+15	1	1	1	0
+12.5	1	1	0	1
+10	1	1	0	0
+7.5	1	0	1	1
+5	1	0	1	0
+2.5	1	0	0	1
0	1	0	0	0
0*	0	0	0	0
-2.5	0	0	0	1
-5	0	0	1	0
-7.5	0	0	1	1
-10	0	1	0	0
-12.5	0	1	0	1
-15	0	1	1	0
-17.5	0	1	1	1

*: Default Value

■2nd VOLUME (Select Address : 03H)

Gain(dB)	03H			
	D3	D2	D1	D0
0*	1	1	1	1
-2	1	1	1	0
-4	1	1	0	1
-6	1	1	0	0
-8	1	0	1	1
-10	1	0	1	0
-12	1	0	0	1
-14	1	0	0	0
-16	0	1	1	1
-18	0	1	1	0
-20	0	1	0	1
-22	0	1	0	0
-24	0	0	1	1
-26	0	0	1	0
-28	0	0	0	1
MUTE	0	0	0	0

*: Default Value

■SOUND GAIN (Select Address : 04H)

SOUND GAIN	04H
	D6
Gain Lo*	0
Gain Hi	1

*: Default Value

■Sound Enhancement Mode (Select Address : 04H)

SOUND MODE	04H	
	D5	D4
OFF*	0	0
ealaTreble	0	1
eala	1	0
eala & ealaTreble	1	1

*: Default Value

■Dynamic Bass Boost Gain (Select Address : 04H)

DBB GAIN	04H	
	D3	D2
OFF*	0	0
Gain 1	0	1
Gain 2	1	0
Gain 3	1	1

*: Default Value

■ Dynamic Bass Boost Sense (Select Address : 04H)

DBB SENSE	04H	
	D1	D0
Sense 1*	0	0
Sense 2	0	1
Sense 3	1	0
Sense 4	1	1

*: Default Value

NJW1201A

■TERMINAL DESCRIPTION

No.	SYMBOL	FUNCTION	EQUIVALENT CIRCUIT	VOLTAGE
2 3 4 36 37 38 40 42 44 47 50 52	IN3A IN2A IN1A IN1B IN2B IN3B IN4B IN5B IN6B IN6A IN5A IN4A	Ach Input3 Ach Input2 Ach Input1 Bch Input1 Bch Input2 Bch Input3 Bch Input4 Bch Input5 Bch Input6 Ach Input6 Ach Input5 Ach Input4		V+ / 2
5 6 13 15 17 22 34 35	MonOutA RecOutA BPF1 BPF3 OutA OutB RecOutB MonOutB	Ach Monitor Output Ach Rec Output Filter 1 for DBB Filter 3 for DBB Ach Output Bch Output Bch Rec Output Bch Monitor Output		V+ / 2
7 33	VOLInA VOLInB	Ach 1 st Volume Input Bch 1 st Volume Input		V+ / 2
8 10 12 28 30 32	TONEHA TONEM2A TONEB2A TONEB2B TONEM2B TONEHB	Ach Treble(Tone) Filter Ach Middle(Tone) Filter 2 Ach Bass(Tone) Filter 2 Bch Bass(Tone) Filter 2 Bch Middle(Tone) Filter 2 Bch Treble(Tone) Filter		V+ / 2

■TERMINAL DESCRIPTION

No.	SYMBOL	FUNCTION	EQUIVALENT CIRCUIT	VOLTAGE
9 11 29 31	TONEM1A TONEB1A TONEB1B TONEM1B	Ach Middle(Tone) Filter 1 Ach Bass(Tone) Filter 1 Bch Bass(Tone) Filter 1 Bch Middle(Tone) Filter 1		V+ / 2
14	BPF2	Filter 2 for DBB		V+ / 2
16 23	VOL2CAPA VOL2CAPB	Ach DC coupling for 2 nd Volume Bch DC coupling for 2 nd Volume		V+ / 2
18	GND	ground	-	0

NJW1201A

■TERMINAL DESCRIPTION

No.	SYMBOL	FUNCTION	EQUIVALENT CIRCUIT	VOLTAGE
19 20	SDA SCL	I2C DATA I2C CLOCK		-
21	V+	Supply Voltage	-	V+
24	ExtSense	AGC Boost Level for DBB		V+ / 2
25	INT	AGC Smoothing Filter for DBB		-

■TERMINAL DESCRIPTION

No.	SYMBOL	FUNCTION	EQUIVALENT CIRCUIT	VOLTAGE
26	SurTC	Filter for Sound Mode		$V+ / 2$
27	SRFil	Filter for Sound Mode		$V+ / 2$
45	VREF	Reference Voltage		$V+ / 2$
46	IN6Diff	Negative Input for Input6		$V+ / 2$

NJW1201A

TEST Circuit

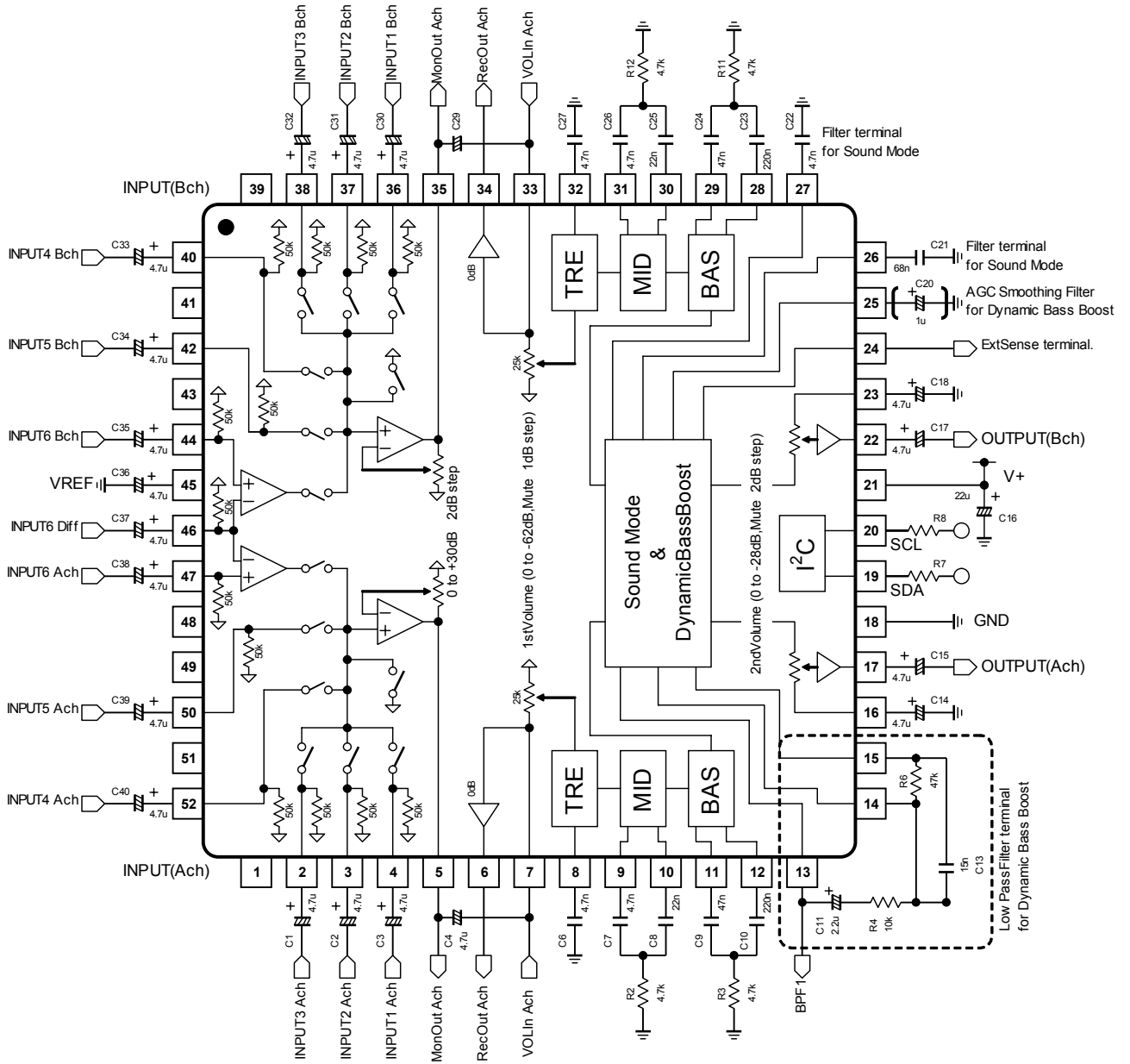

■ Application Circuit

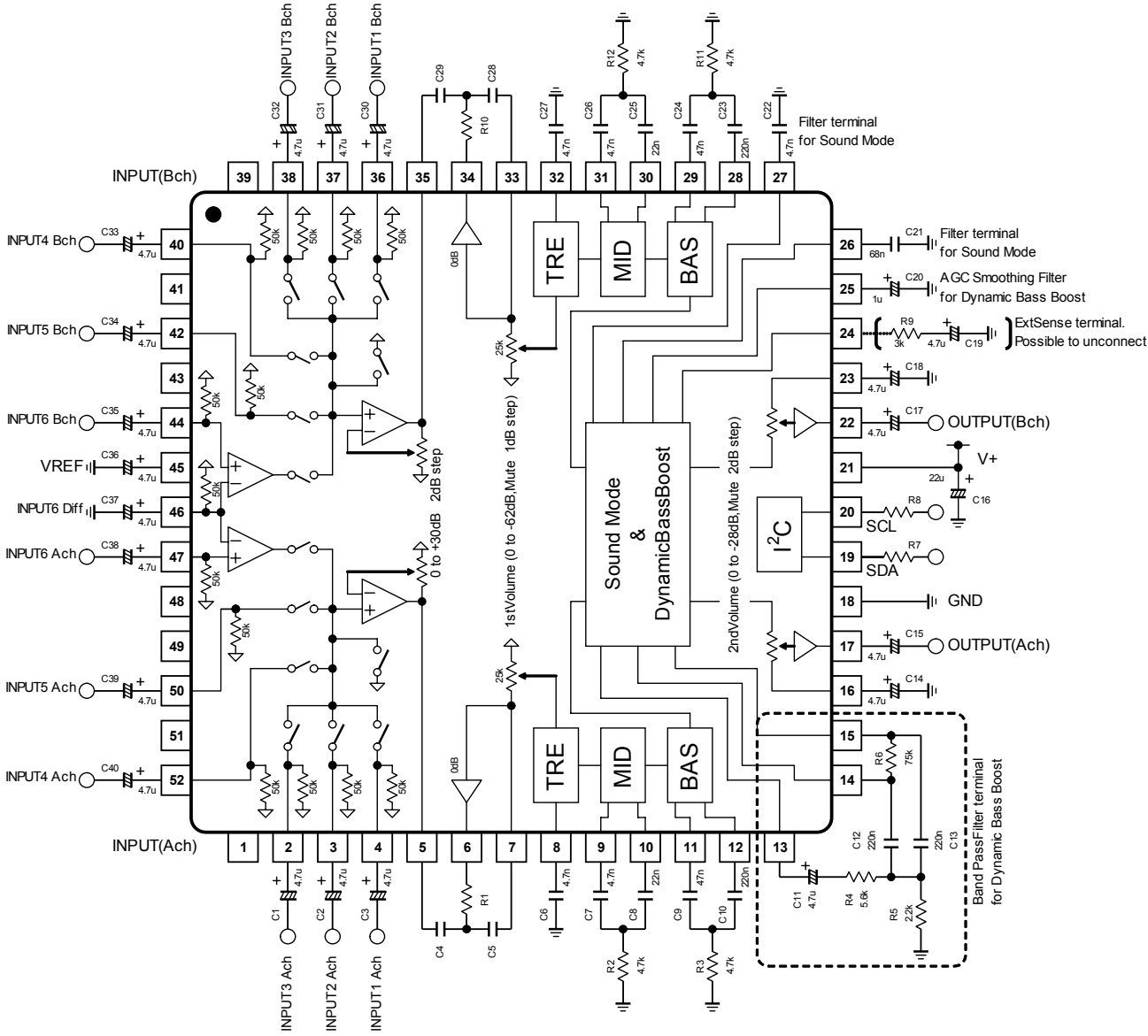

■ APPLICATION NOTE

[1] Input Selector

(1-1) Single ended stereo Inputs

All single ended inputs (pin.2,3,4,36,37,38,40,42,44,47,50,52) have an input impedance of **50kΩ**.

(1-2) Differential Input

In6A(pin.47)/In6B(pin.44) can use as single-ended input or differential input.

In case of differential input, In6A/In6B are positive input have an input impedance of **50kΩ**.

And In6diff(pin.46) is negative input terminal has an input impedance of **50kΩ**.

To improve CMRR at input, please connect the same value of coupling capacitor to In6A/In6B/In6diff.

[2] Monitor out(pin.5,35), Rec out(pin6,34), VOLIn(pin.7,33)

Hi-path filter (Sallen-Key) can be made up with these terminals.

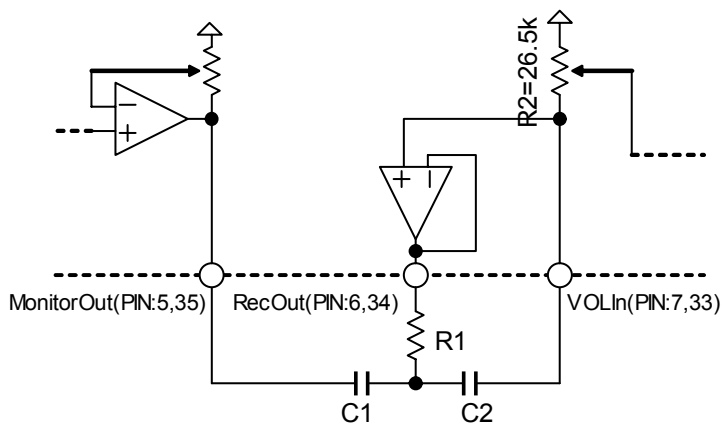

$$f_0 = \frac{1}{2\pi\sqrt{R_1 R_2 C_1 C_2}}$$

$$Q = \frac{C_1 C_2}{C_1 + C_2} \frac{R_2}{\sqrt{R_1 R_2 C_1 C_2}}$$

APPLICATION NOTE

[3] TONE control

(a) Bass

(a-1) Boost

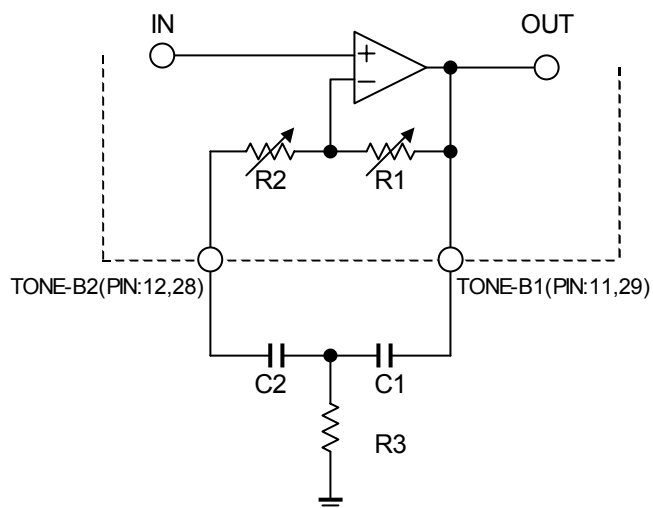

(a-2) Cut

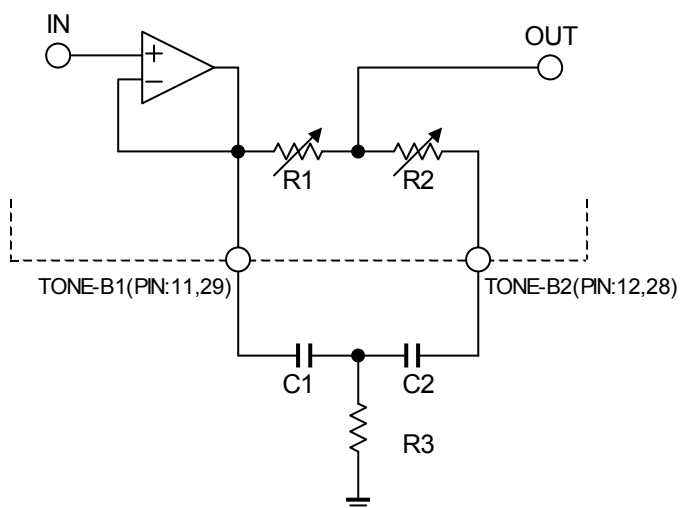

$$f_0 = \frac{1}{2\pi\sqrt{(R1 + R2) * R3 * C1 * C2}} \quad (\text{Hz})$$

$$Q = \frac{\sqrt{(R1 + R2) * R3 * C1 * C2}}{R2 * C2 + R3 * (C1 + C2)}$$

$$G_0 = \pm 20 \text{Log} \frac{(R1 + R2 + R3) * C2 + R3 * C1}{R2 * C2 + R3 * (C1 + C2)} \quad (\text{dB})$$

Table.a-1 : Internal resistance in each Gain.

Gain	R1	R2
±17.5dB	48.3kΩ	1.7kΩ
±15dB	45.8kΩ	4.2kΩ
±12.5dB	42.5kΩ	7.5kΩ
±10dB	38.1kΩ	11.9kΩ
±7.5dB	32.2kΩ	17.8kΩ
±5dB	24.4kΩ	25.6kΩ
±2.5dB	13.9kΩ	36.1kΩ
±0dB	0Ω	50kΩ

(b)Middle
(b-1)Boost

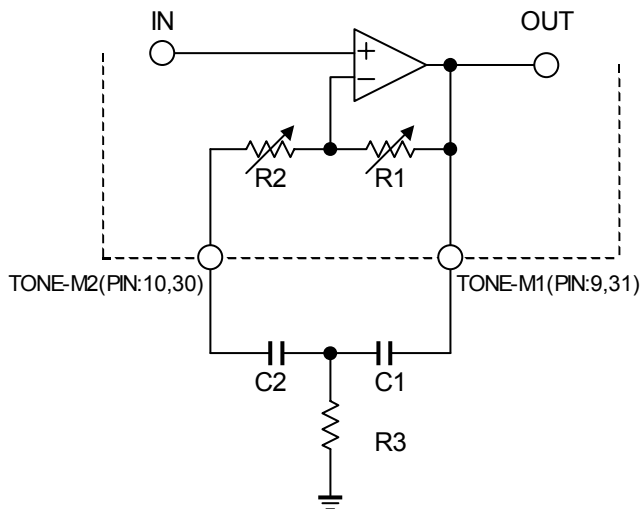

(b-2)Cut

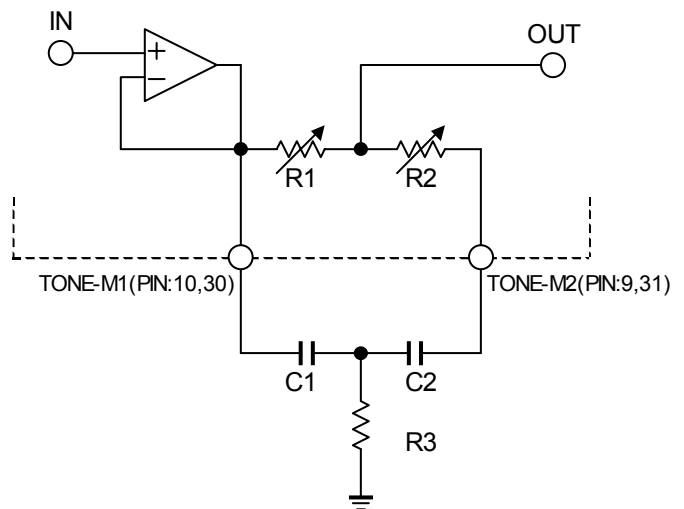

$$f_0 = \frac{1}{2\pi\sqrt{(R1 + R2) * R3 * C1 * C2}} \quad (\text{Hz})$$

$$Q = \frac{\sqrt{(R1 + R2) * R3 * C1 * C2}}{R2 * C2 + R3 * (C1 + C2)}$$

$$G_0 = \pm 20 \text{Log} \frac{(R1 + R2 + R3) * C2 + R3 * C1}{R2 * C2 + R3 * (C1 + C2)} \quad (\text{dB})$$

Table.a-1 : Internal resistance in each Gain.

Gain	R1	R2
±14dB	44.6kΩ	5.4kΩ
±12dB	41.7kΩ	8.3kΩ
±10dB	38.1kΩ	11.9kΩ
±8dB	33.6kΩ	16.4kΩ
±6dB	27.8kΩ	22.2kΩ
±4dB	20.6kΩ	29.4kΩ
±2dB	11.5kΩ	38.5kΩ
±0dB	0Ω	50kΩ

(c)Treble
(c-1)Boost

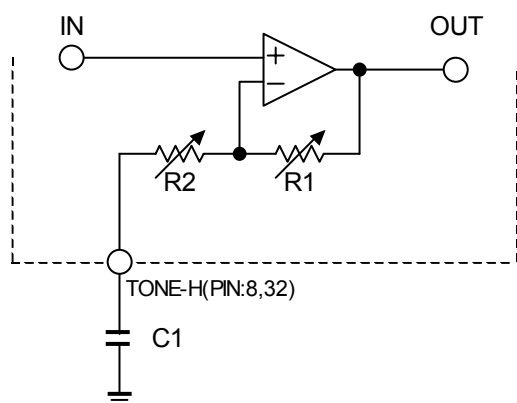

(c-2)Cut

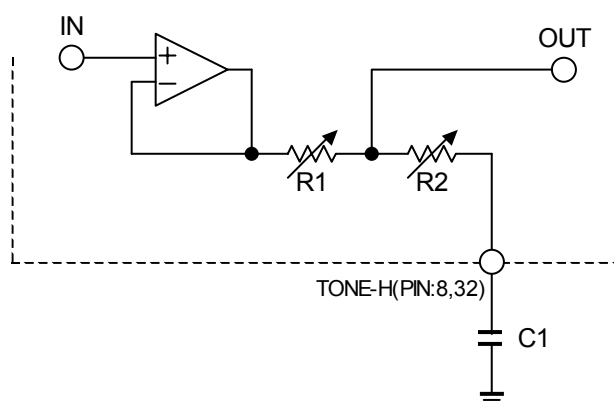

$$G_V = \pm 20 \text{Log} \left[1 + \frac{R1}{R2} \times \frac{1}{\sqrt{1 + (1/(2\pi \times f \times C1 \times R2))^2}} \right] \quad (\text{dB})$$

Table.a-1 : Internal resistance in each Gain.

Gain	R1	R2
±14dB	22kΩ	4kΩ
±12dB	20.2kΩ	5.8kΩ
±10dB	18.4kΩ	7.6kΩ
±8dB	16.1kΩ	9.9kΩ
±6dB	13.3kΩ	12.7kΩ
±4dB	9.8kΩ	16.2kΩ
±2dB	5.5kΩ	20.5kΩ
±0dB	0Ω	26kΩ

APPLICATION NOTE

[4] Sound Mode

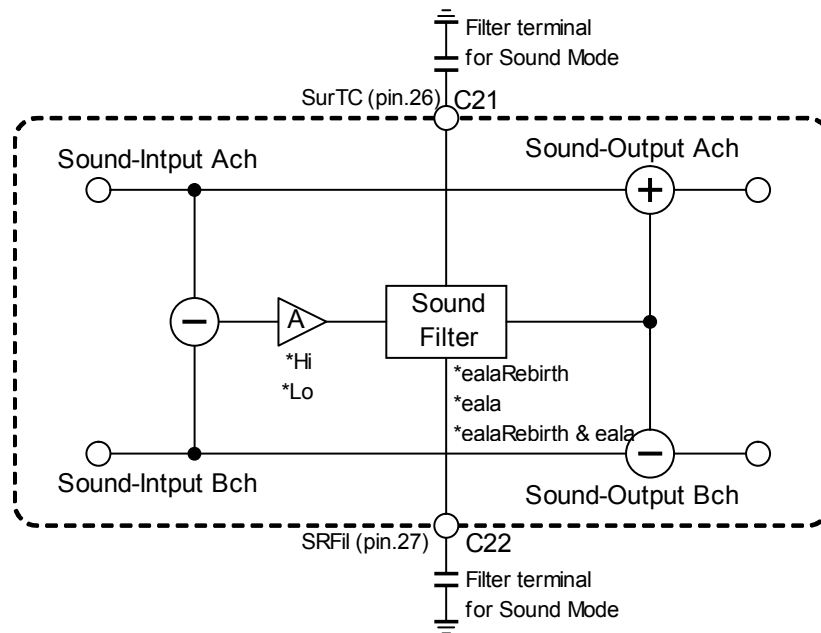

There are 3 sound modes in NJW120A.

- 1) ealaRebirth : This is a sound effect, this is suitable for compressed Audio.
- 2) eala : This is a comfortable surround that makes much of sound location.
- 3) ealaRebirth & eala : This is a sound effect that be suitable for various music.

These sound modes have 2-level gain effects.

Sound modes and 2-level gain are switched by I2C command.

And, Frequency effects of sound mode depends on C21,C22.

Please choose your suitable value of C21,C22 for Audio set.

Recommendation is C21=68nF, C22=4.7nF.

Frequency Response of Sound mode is shown in next page.

Regarding Pop noise reduction when sound mode and sound gain switched NJW1201A doesn't cover about this.

*Notice: About NJW1201

Regarding Pop noise reduction when sound mode and sound gain switched,

*Sound mode switched: Pop noise reduction is cared by capacitor pin.26

*Sound gain switched: Pop noise reduction is not cared

Gain vs Frequency (ealaRebirth)

V+=9V, Vin(Ach)=0.1Vrms, Vo(Ach), Ta=25°C

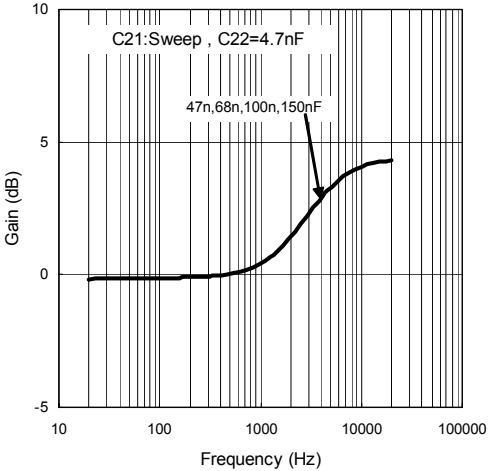

Gain vs Frequency (ealaRebirth)

V+=9V, Vin(Ach)=0.1Vrms, Vo(Ach), Ta=25°C

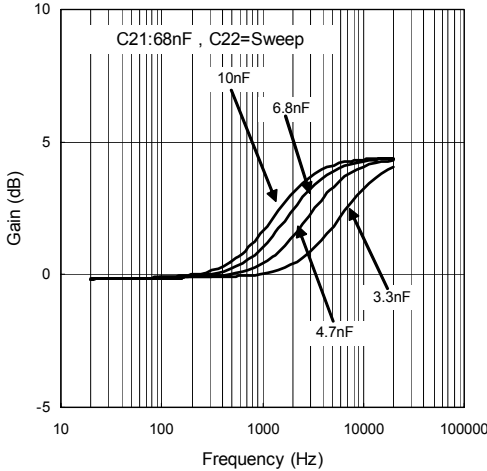

Gain vs Frequency (eala)

V+=9V, Vin(Ach)=0.1Vrms, Vo(Ach), Ta=25°C

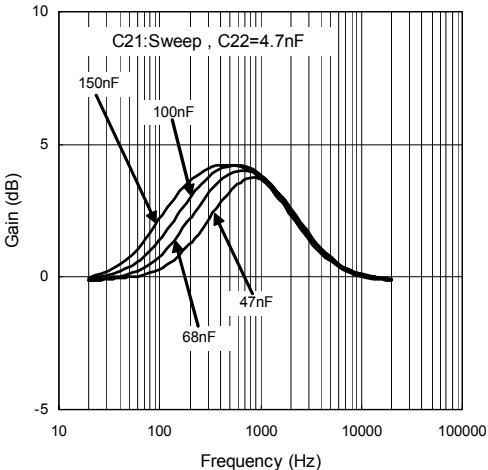

Gain vs Frequency (eala)

V+=9V, Vin(Ach)=0.1Vrms, Vo(Ach), Ta=25°C

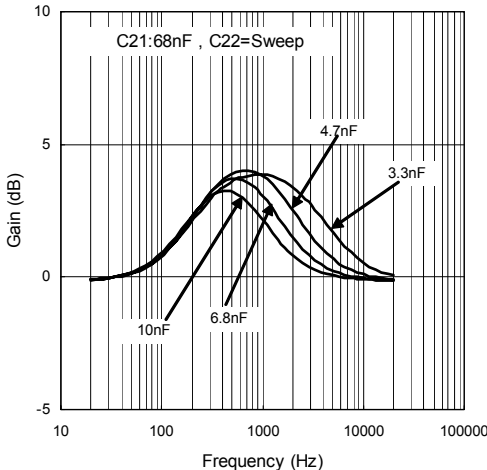

Gain vs Frequency (eala+ealaRebirth)

V+=9V, Vin(Ach)=0.1Vrms, Vo(Ach), Ta=25°C

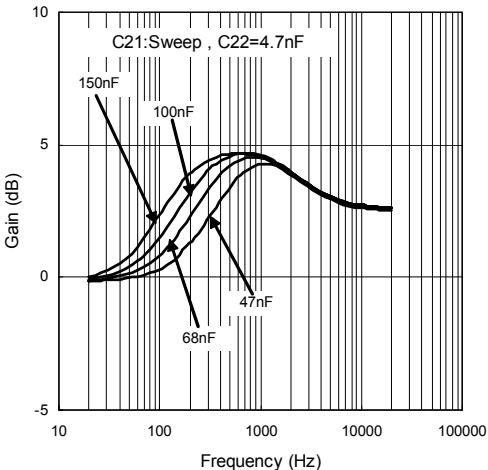

Gain vs Frequency (eala+ealaRebirth)

V+=9V, Vin(Ach)=0.1Vrms, Vo(Ach), Ta=25°C

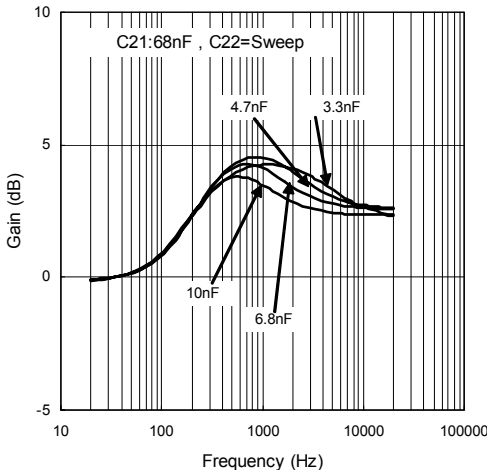

APPLICATION NOTE

[5] Dynamic Bass Boost (DBB)

5-1. Block diagram of DBB

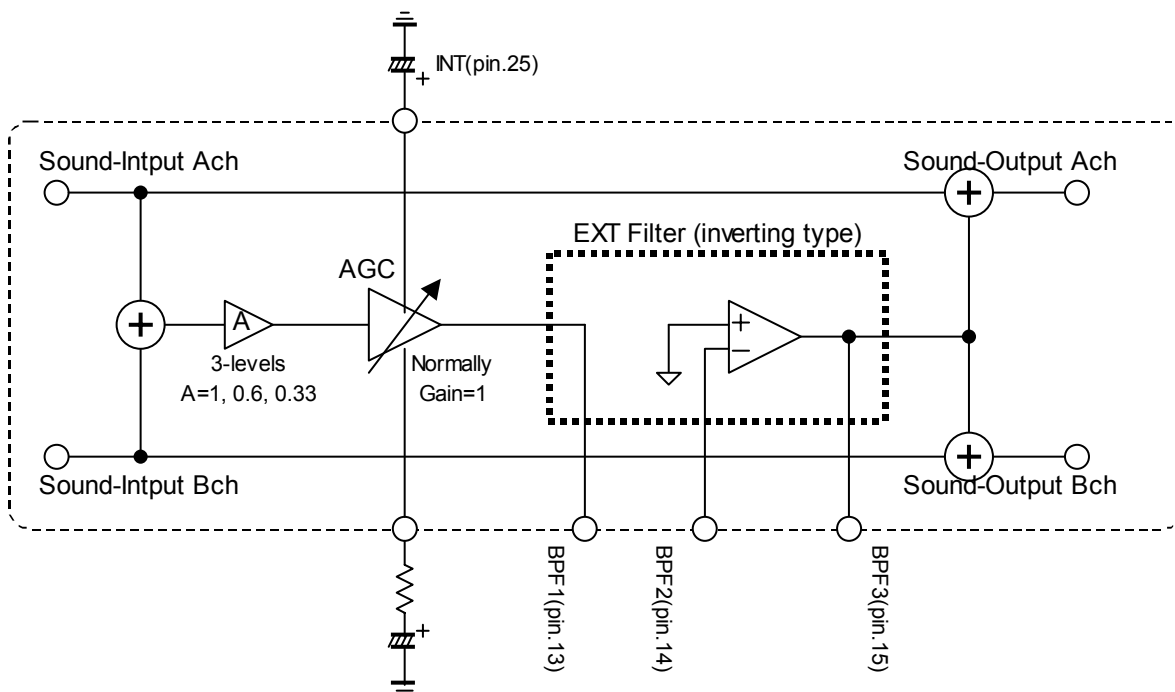

Dynamic Bass Boost (DBB) is a system that changes boost gain by changing of input level. The boost gain has 3-levels, this is controlled by I2C. AGC circuit changes the boost gain by detecting the input signal.

5-2. Setting of EXT Filter

The Frequency Response of DBB can be changed in EXT Filter. EXT Filter is composed of BPF1(pin.13), BPF2(pin.14), BPF3(pin.15). Below are examples of filter structure.

a) BPF

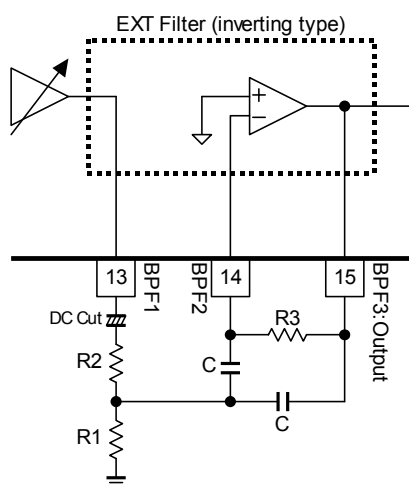

$$G_v = 20 \log \left(\frac{R_3}{2R_2} \right)$$

$$f_c = \frac{1}{2\pi C \sqrt{(R_1 // R_2) R_3}}$$

$$Q = \frac{1}{2} \sqrt{\frac{R_3}{R_1 // R_2}}$$

b) LPF (-6dB/Oct)

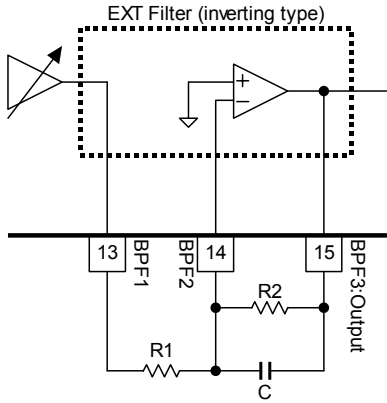

$$G_v = 20 \log \left(\frac{R_2}{R_1} \right)$$

$$f_c = \frac{1}{2\pi C R_2}$$

c) LPF (-12dB/Oct)

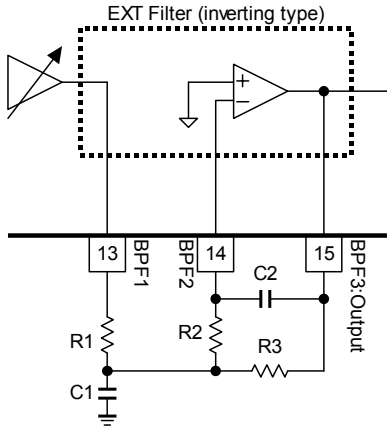

$$G_v = 20 \log \left(\frac{R_3}{R_1} \right)$$

$$f_c = \frac{1}{2\pi \sqrt{C_1 C_2 R_2 R_3}}$$

5-3. DBB INT

external Capacitor connected to pin.25 decides Attack/Recovery time of DBB.

Recovery time (s) = 0.5 X C(uF)

(test condition : Vin(Ach+Bch)=2Vrms, Sense Level = 4)

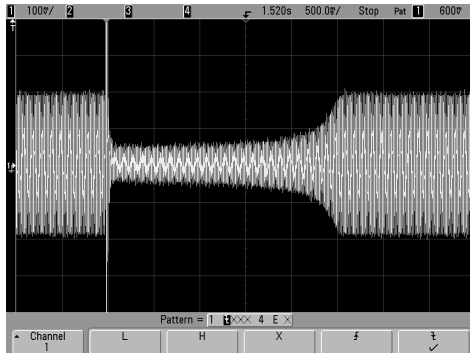

Recovery time (C=4.7uF)
Vin=2 → 0.2Vrms f=70Hz

5-4. Detective level in DBB

Detective level of input signal in DBB is control by I2C or external resistor (Rsense:pin.24).

In case of without external resistor, Detective level is shown in below Fig5-4-1, 5-4-2.

Fig5-4-1 is Output Voltage vs Input Voltage when detective level is changed (Gain setting = 3).

Fig5-4-2 is Output Voltage vs Input Voltage when Gain setting is changed (Sense level = 4).

These figures don't include the external Resistor (Rsense:pin.24).

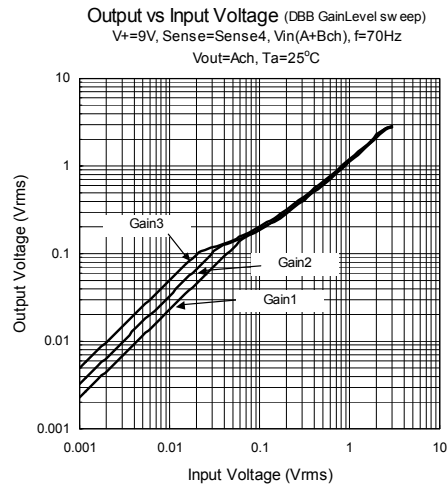
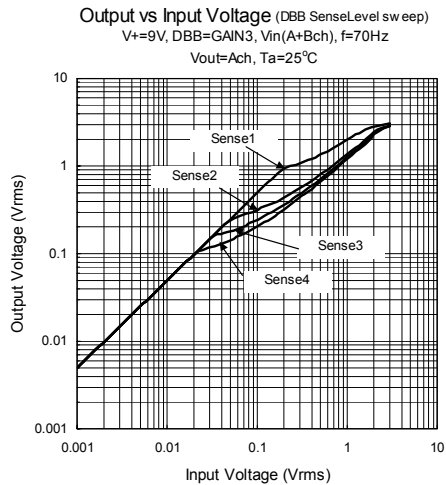

Regarding Detective Level (sense level), internal resistance is switched by I2C.

This resistance decides detective level.

1. Sense 1 = 36kΩ
2. Sense 2 = 9kΩ
3. Sense 3 = 5.2kΩ
4. Sense 4 = 3.6kΩ

And, if connect the external resistor (Rsense:pin.24), Detected level is shown in below equations.

1. Sense 1 = 36kΩ // Rsense
2. Sense 2 = 9kΩ // Rsense
3. Sense 3 = 5.2kΩ // Rsense
4. Sense 4 = 3.6kΩ // Rsense

APPLICATION NOTE

[6] 2nd Volume

2nd Volume range is 0dB to -28dB with -2dB steps.

Frequency response of 2nd Volume depends on capacitor connected to VOL2CAP(pin.16,23).

It shows frequency response of 2nd Volume in Fig.6-1(2nd Volume=-28dB), Fig6-2(2nd Volume=MUTE).

To flat the frequency response, please choose bigger capacitor.

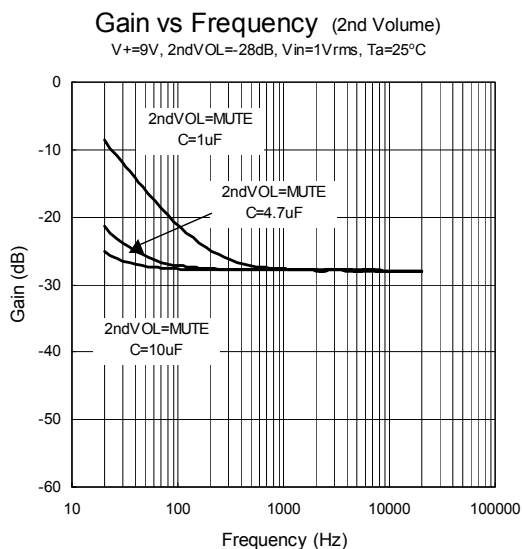

Fig.6-1

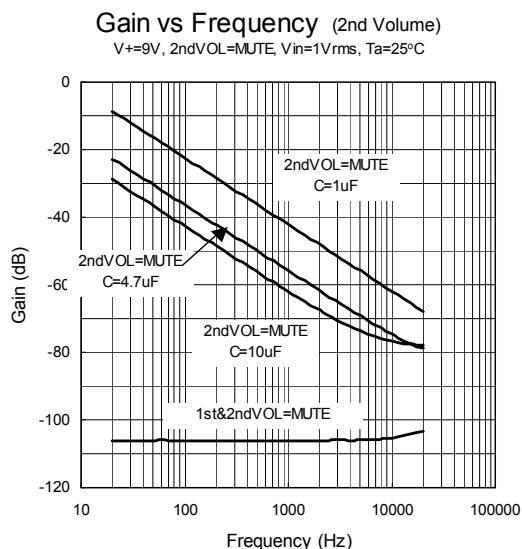

Fig.6-2

But, when power turns on, it takes some charge time to VOL2CAP(pin.16.23)

If 2nd Volume is switched on charge, Pop noise occurs.

The cause of pop noise is gap of Voltage between Vref and VOL2CAP.

To be fast the charge time, connect smaller capacitor to VOL2CAP.

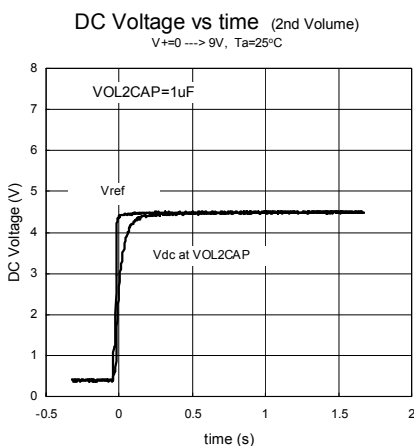

Fig.6-3.VOL2CAP=1uF

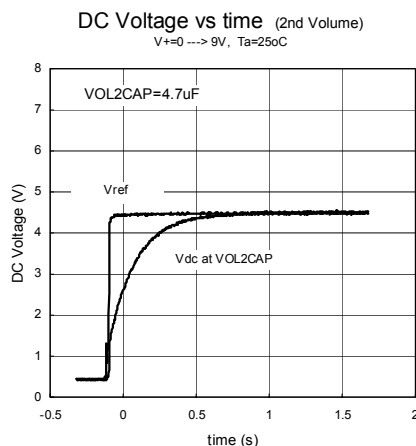

Fig.6-4.VOL2CAP=4.7uF

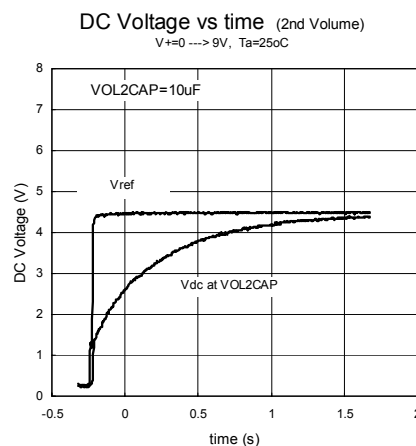

Fig.6-4.VOL2CAP=10uF

[CAUTION]

The specifications on this databook are only given for information, without any guarantee as regards either mistakes or omissions. The application circuits in this databook are described only to show representative usages of the product and not intended for the guarantee or permission of any right including the industrial rights.