

THREE-PHASE DC BRUSHLESS MOTOR CONTROL IC

■ GENERAL DESCRIPTION

The NJW4302 is a three-phase DC brushless motor pre-driver IC for precision applications.

The NJW4302 consists of PWM driver, motor velocity control, FG(Frequency Generator) output, and voltage velocity integration circuit.

The NJW4302 realizes stabilized velocity and it is suitable for printer, FAX, and other DC motor control systems.

■ PACKAGE OUTLINE

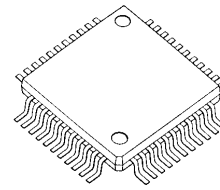

NJW4302FA1

■ FEATURES

- Speed discriminator and PLL speed control circuit
- Direct PWM driver
- CR oscillator
- Lock protection output
- Break circuit (short circuit braking)
- Start/stop switch Start/Stop Switch Circuit
- Current limit circuit
- Thermal shut down/Under voltage lockout circuit
- FG output amplifier/Integrating circuit
- Shunt regulator output : 5V
- Bi-CMOS technology
- PACKAGE OUTLINE QFP44

■ PIN CONFIGURATION

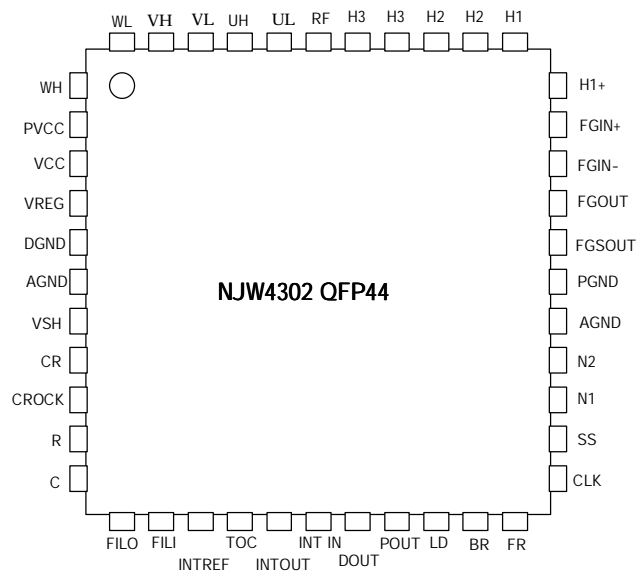

■ BLOCK DIAGRAM

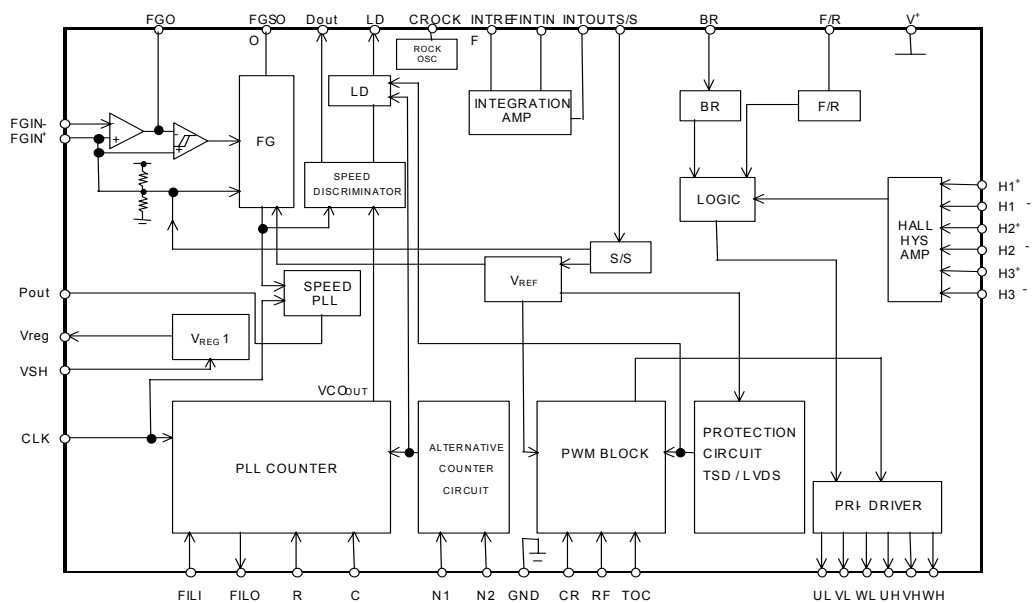

■PIN DESCRIPTION

SYMBOL	PIN No.	DESCRIPTION
H1+,H1-	33, 34	Hall input pins
H2+,H2-	35, 36	Positive input terminal is defined as IN ⁺ ,Negative input terminal as IN ⁻ respectively.
H3+,H3-	37, 38	Positive input is defined as IN ⁺ > IN ⁻ as Negative.
UH	41	Output pins(for fixed current source)
VH	43	
WH	1	
UL	40	Output pins(open collector sink outputs).
VL	42	Duty control implement with PWM signal.
WL	44	
VPCC	2	Power-supply voltage pin
VCC	3	Connect a noise decoupling capacitor between these pins and the ground.
VREG	4	Shunt regulator output pin
PGND.DGND	5,6	Ground pins
AGND	27,28	These pins are all connected internally to the ground(GND).
VSH	7	Shunt regulator ON/OFF output pin "H" or open:ON "L":OFF
CR	8	PWM oscillator frequency setting pin Three blocks use the oscillator: motor constraint detection circuit, clock disconnection protection circuit and others
CROCK	9	Reference clock signal oscillator pin Connect a capacitor between this pin to the ground.This oscillator provides clock signal when motor is locked.
R	10	VCO oscillation frequency setting pin Connect a resistor between this pin and the ground.
C	11	VCO oscillation frequency setting pin Connect a resistor between this pin and ground. Set the value of the capacitor so that the oscillator frequency does not exceed 1MHz.
FILI	13	VCO filter amplifier input pin This pin is connected to VCO PLL output with 10KΩ resistor internally in the IC.
FILO	12	VCO filter amplifier output pin This pin is connected to VCO circuit internally in the IC.
D OUT	18	Speed discriminator output pin Output"L"level for over speed.
P OUT	19	PLL output pin Output the phase comparison result for 1/2fCLK and 1/2fFG.
LD	20	Lock detection output pin Open collector becomes"L"within the speed lock range(±6.25).
INT REF	14	Integrating amplifier forward rotation input(a potential of 1/2V ⁺)
INT IN	17	Negative input for Integration amplifier
INT OUT	16	Output for Integration amplifier
TOC	15	Torque command input pin This pin is normally connected to the INT OUT pin. When the TOC voltage level falls,the UL,VL and WI PWM duties are changed to increase.
FG IN+	32	Input pin for FG amplifier forward rotation (a potential of 1/2V ⁺) Connect a noise decoupling capacitor between V ⁺ terminal and the ground.

FG IN-	31	FG amplifier reverse rotation input.
FGOUT	30	FG amplifier output.
FGSOUT	29	FG amplifier output(after the schmitt) Open collector output.
RF	39	Output current detection Connect a resistor between this pin and GND pin.The output limitation maximum current(IOUT)is set to be $0.5/R_f$.
SS	24	Start:Stop control "L":Start "H"or Open:Stop
FR	22	Forward/reverse rotation control "L":Forward "H"or Open:reverse
BR	21	Brake control (short braking operation) "L":Start "H"or Open:Brake
CLK	23	External clock signal input 10kHz max.
N1	25	Speed discriminator count switching
N2	26	

NJW4302

■ FUNCTIONAL DESCRIPTION

1. VCO circuit

The variable range of PLL circuit is determined by two factors: VCO frequency determined by RC value connected to Pin 15 and Pin 16 and VCO loop filter constants. VCO frequency range must be within 160kHz to 1.0MHz.

The typical external value is as follows:

$$R=20k\Omega, C=100pF.$$

The filter constants are $C=0.47\mu F, R=27k\Omega$.

2. Output drive circuit

The PWM control is made by upper side of external transistor.

3. Speed lock range

The speed lock range is $\pm 6.25\%$ of fixed speed. When the motor speed is within the lock range, the LD pin (an open collector output) goes "L". If the motor speed goes out of the lock range, the LD pin goes "H".

Please be noted that the LD signal may go on during startup.

4. PWM frequency

The PWM frequency is determined by resistor and capacitor value connected to the CR pin.

The PWM frequency is given by expressed as:

$$f_{PWM} = 1 / (0.48CR)$$

When $C=1500pF, R=75K\Omega$, the PWM frequency goes about 19KHz.

5. Lock detection circuit(CLOCK)

Lock detection circuit protects the driver IC and the motor from fatal over current failure when the motor is locked during startup. If the LD output remains "H" (motor lock state) for a certain period (Hold time), all phase of upper side transistors are to be turned off.

The hold time can be programmed by capacitor value attached to the CLOCK pin by the following:

$$\text{Set time(sec)} = 66 \times C(\mu F)$$

With $C=0.068\mu F$, the hold time can be programmed for approximately 4.5 sec.

Once Lock detection circuit is activated, the state remains unchanged unless it is turned off, or stopped.

This function can be disabled when the CLOCK pin is connected to the ground.

6. Forward / Reverse(F/R)Switching

The direction control can be made with the state of the F/R pin. The direction can be changed even during the motor in motion.

7. Brake Switch

NJW4302 uses a short brake method that turns on all phase of upper side transistors for braking. During the time, all lower side transistors are turned off.

8. VREG pin/VSH pin

NJW4302 includes a regulator to generate for +5V regulated IC supply when the motor drive circuit is designed with a single power supply. The VREG pin and V+ pin compose a shunt regulator for $5V \pm 5\%$ output with a external resistor and a transistor. To use the regulator, the VSH pin must be either "H", or Open. Otherwise, the VSH pin must be "L" and the VREG pin is to be opened.

9. Frequency Generator (FG) Amplifier

The internal FG amplifier with few passive components composes a filter amplifier shown in the application. Circuit for noise rejection. The output voltage of the amplifier must be at least 250mA p-p since it feature Schmitt comparator.

The capacitor connected between the FGIN+ pin and the ground is necessary for bias voltage stabilization and initial reset pulse generation for the internal logic. The reset pulse is generated when the FGIN+ pin goes from 0 to approximately 1.25V.

10. Integration Amplifier

The integration amplifier integrates the D-out and P-out and converts them to speed command voltage. During the time, it also sets the control loop gain and frequency characteristics using external components.

11. Speed Control Circuit

NJW4302 features two speed control method; speed discriminator circuit with PLL circuit and phase comparison circuit. The FG pulse frequency is controlled to be the same frequency with a clock frequency input to the CLK pin. Therefore, the motor speed can be controlled by changing the clock frequency.

The motor speed (N) can be expressed as:

$$N = \text{CLK (Hz)} \times (60/\text{FGP}) [\text{RPM}] \quad (\text{FGP: Number of FG pulse per one rotation})$$

Given that the oscillation frequency range is 160kHz~1.0MHz and the number of counts is 1024, the range of clock frequency is 156Hz~960Hz, and therefore the motor speed can be changed from 260rpm to 1600rpm.

NJW4302

■ABSOLUTE MAXIMUM RATING

PARAMETER	SYMBOL	TEST CONDITION	RATINGS	UNIT
Maximum supply voltage	V+		7	V
Maximum input current	Ireg	Vreg pin(5.6V)	10	mA
Output current	Io	UL,VL,WL	30	mA
Operating temperature	Topr		-40~85	°C
Storage temperature	Tstg		-55~150	°C
Power dissipation	Pd		700	mW

■ALLOWABLE MAXIMUM RANGES/Ta=25°C

PARAMETER	SYMBOL	CONDITION	RATINGS	UNIT
Input current range	I _{REG}	V _{REG} pin=5.6V	1.0~5.0	mA
FG Schmitt output applied voltage	V _{FGSO}		0~8	V
FG Schmitt output current	I _{FGSO}		0~5	mA
Lock detection output current	I _{LD}		0~20	mA
Supply voltage	V ⁺		4.5~5.5	V

■ELECTRICAL CHARACTERISTICS / Ta=25°C,V+=5.0V

PARAMETER	SYMBOL	CONDITION	MIN.	TYP.	MAX.	UNIT
Supply current 1	Icc1		-	38	55	mA
Supply current 2	Icc2	in stop mode	-	8	18	mA
Output saturation voltage	Vo(sat)	UL,VL and WL terminal I _o =20mA	-	0.2	0.7	V
Output current	I _o	UH,VH and WH _{terminal} V _{out} =1.4V	-20	-16	-12	mA
Output leakage current	I _o (leak)	UL,VL,WL output	-	-	100	μA
Output off voltage	Vo(off)	UH,VH,WH output	-	-	0.5	V

●HALL AMPLIFIER

PARAMETER	SYMBOL	TEST CONDITION	MIN.	TYP.	MAX.	UNIT
Input bias current	I _{HB} (HA)		-4	-1	-	μA
Common mode input voltage range	V _{ICM}		1.5	-	VCC-1.5	V
Hall input sensitivity	ΔV _{IN} (HA)		-	60	-	mV _{P-P}
Hysteresis	ΔV _{IN} (HA)		17	32	60	mV
Input voltage Low → High	V _{SLH}		8	16	30	mV
Input voltage High →Low	V _{SHL}		-30	-16	-8	mV

●CR OSCILLATOR

PARAMETER	SYMBOL	TEST CONDITION	MIN.	TYP.	MAX.	UNIT
Output high level voltage	V _{OH} (CR)		2.4	2.7	3.0	V
Output low level voltage	V _{OL} (CR)		1.3	1.6	1.9	V
RC oscillation frequency	f(CR)	R=75kΩ,C=1500pF	-	19	-	kHz
RC oscillation voltage	V(CR)		0.9	1.1	1.3	V _{P-P}

●CLOCK OSCILLATOR

PARAMETER	SYMBOL	TEST CONDITION	MIN.	TYP.	MAX.	UNIT
Output high level voltage	V _{OH} (RK)		2.7	3.0	3.3	V
Output low level voltage	V _{OL} (RK)		0.1	0.4	0.7	V
External capacitor charge current	I _{CHG1}		-	-10	-	μA
External capacitor discharge current	I _{CHG2}		-	10	-	μA
Clock oscillation frequency	f(RK)	C=0.068μF	-	35	-	Hz
RC oscillation voltage	V(RK)		2.4	2.6	2.8	V _{P-P}

●VCO OSCILLATOR (PLL COUNTER)

PARAMETER	SYMBOL	TEST CONDITION	MIN.	TYP.	MAX.	UNIT
C-terminal high-level output voltage	V _{OH} (C)		1.15	1.25	1.35	V
C-terminal low-level output voltage	V _{OL} (C)		0.9	1.0	1.1	V
VCO oscillation frequency	f(C)		-	-	1.0	MHz
Amplitude	V(C)		0.15	0.25	0.6	V _{P-P}

●CURRENT LIMITING OPERATION

PARAMETER	SYMBOL	TEST CONDITION	MIN.	TYP.	MAX.	UNIT
Limiter	V_{RF}		0.47	0.52	0.57	V

●FG AMPLIFIER

PARAMETER	SYMBOL	TEST CONDITION	MIN.	TYP.	MAX.	UNIT
Input offset voltage	$V_{IO}(FG)$		-10	0	10	mV
Input bias current	$I_B(FG)$		-1	0	1	μA
Output low-level voltage	$V_{OH}(FG)$		$V^+ - 1.5$	$V^+ - 1.0$	-	V
Output high-level voltage	$V_{OL}(FG)$		-	1	1.5	V
FG input sensitivity	$\Delta V_{IN}(FG)$	GAIN = 40dB	-	3	-	mV
Schmitt amplifier for next stage	$\Delta V_{SH}(FG)$		100	180	250	mV
Operating frequency range	ΔFG		-	16	-	kHz
Open loop gain	$A_V(FG)$	$f(FG) = 2kHz$	-	51	-	dB

●FGSO OUTPUT

PARAMETER	SYMBOL	TEST CONDITION	MIN.	TYP.	MAX.	UNIT
Output saturation voltage	$V_O(FGSO)$	$I_O(FGS) = 2mA$	-	0.1	0.5	V
Output leak current	$I_L(FGSO)$	$V_O = V^+$	-	-	10	μA

●SPEED DISCRIMINATOR OUTPUT (Dout)

PARAMETER	SYMBOL	TEST CONDITION	MIN.	TYP.	MAX.	UNIT
Output high-level voltage	$V_{OH}(D)$		$V^+ - 1.0$	$V^+ - 0.7$	-	V
Output low-level voltage	$V_{OL}(D)$		-	0.4	-	V

●SPEED CONTROL PLL OUTPUT (Pout)

PARAMETER	SYMBOL	TEST CONDITION	MIN.	TYP.	MAX.	UNIT
Output high-level voltage	$V_{OH}(P)$		3.35	3.65	3.95	V
Output low-level voltage	$V_{OL}(P)$		1.35	1.65	1.95	V

●LOCK DETECTION (LD)

PARAMETER	SYMBOL	TEST CONDITION	MIN.	TYP.	MAX.	UNIT
Output saturation voltage	$V_{OL}(LD)$	$I_{LD} = 10mA$	-	0.1	0.5	V
Output leak current	$I_L(LD)$	$V_O = V^+$	-	-	10	μA
Lock range	$\Delta LOCK$	Design target spec	-6.25	-	+6.25	%

●INTEGRATER AMPLIFIER

PARAMETER	SYMBOL	TEST CONDITION	MIN.	TYP.	MAX.	UNIT
Input offset voltage	$V_{IO(INT)}$		-10	-	10	mV
Input bias current	$I_{B(INT)}$		-0.4	-	0.4	μA
Output high-level voltage	$V_{OH(INT)}$		$V^+ - 0.12$	$V^+ - 0.8$	-	V
Output low-level voltage	$V_{OL(INT)}$		-	0.8	1.2	V
Open loop gain	$A_{V(INT)}$		-	60	-	dB
Gain-band width product	$GBW(INT)$		-	1.6	-	MHz
Reference voltage	$V_{B(INT)}$		2.375	2.5	2.625	V

●FILTER AMPLIFIER (PLL COUNTER)

PARAMETER	SYMBOL	TEST CONDITION	MIN.	TYP.	MAX.	UNIT
Input bias current	$I_{B(FIL)}$		-	0.4	-	μA
Output high-level voltage	$V_{OH(FIL)}$		$V^+ - 1.2$	$V^+ - 0.8$	-	V
Output low-level voltage	$V_{OL(FIL)}$		-	0.8	1.2	V
Hysteresis	$V_{B(FIL)}$		2.375	2.5	2.625	V

●S/S AMPLIFIER

PARAMETER	SYMBOL	TEST CONDITION	MIN.	TYP.	MAX.	UNIT
Input high-level voltage	$V_{IH(S/S)}$		3.5	4.2	V^+	V
Input low-level voltage	$V_{IL(S/S)}$		0	0.8	1.0	V
Hysteresis	$\Delta V_{IN(S/S)}$		1.0	1.3	1.6	V
Pull-Up resistance	$R_{U(S/S)}$		60	80	100	$k\Omega$

●F/R AMPLIFIER

PARAMETER	SYMBOL	TEST CONDITION	MIN.	TYP.	MAX.	UNIT
Input high-level voltage	$V_{IH(F/R)}$		3.5	4.2	V^+	V
Input low-level voltage	$V_{IL(F/R)}$		0	0.8	1.0	V
Hysteresis	$\Delta V_{IN(F/R)}$		1.0	1.3	1.6	V
Pull-Up resistance	$R_{U(F/R)}$		60	80	100	$k\Omega$

●BR AMPLIFIER

PARAMETER	SYMBOL	TEST CONDITION	MIN.	TPY.	MAX.	UNIT
Input high-level voltage	$V_{IH(BR)}$		3.5	4.2	V^+	V
Input low-level voltage	$V_{IL(BR)}$		0	0.8	1.0	V
Hysteresis	$\Delta V_{IN(BR)}$		1.0	1.3	1.6	V
Pull-Up resistance	$R_{U(BR)}$		60	80	100	$k\Omega$

NJW4302

•CLK AMPLIFIER

PARAMETER	SYMBOL	TEST CONDITION	MIN.	TPY.	MAX.	UNIT
Input high-level voltage	V _{IH} (CLK)		3.5	4.2	V ⁺	V
Input low-level voltage	V _{IL} (CLK)		0	0.8	1.0	V
Hysteresis	ΔV_{IN} (CLK)		1.0	1.3	1.6	V
Pull-Up resistance	R _U (CLK)		60	80	100	k Ω
Input frequency	f(CLK)		-	16	-	kHz

•N1 AMPLIFIER

PARAMETER	SYMBOL	TEST CONDITION	MIN.	TYP.	MAX.	UNIT
Input high-level voltage	V _{IH} (N1)		3.5	4.2	V ⁺	V
Input low-level voltage	V _{IL} (N1)		0	0.8	1.0	V
Hysteresis	ΔV_{IN} (N1)		1.0	1.3	1.6	V
Pull-Up resistance	R _U (N1)		60	80	100	k Ω

•N2 AMPLIFIER

PARAMETER	SYMBOL	TEST CONDITION	MIN.	TYP.	MAX.	UNIT
Input high-level voltage	V _{IH} (N2)		3.5	4.2	V ⁺	V
Input low-level voltage	V _{IL} (N2)		0	0.8	1.0	V
Hysteresis	ΔV_{IN} (N2)		1.0	1.3	1.6	V
Pull-Up resistance	R _U (N2)		60	80	100	k Ω

•UNDER VOLTAGE LOCKOUT

PARAMETER	SYMBOL	TEST CONDITION	MIN.	TYP.	MAX.	UNIT
Operating voltage	V _{SDL}		-	3.75	-	V
Release voltage	V _{SDH}		-	4.0	-	V
Hysteresis	ΔV_{SD}		0.15	0.25	0.35	V

•SHUNT REGULATOR

PARAMETER	SYMBOL	TEST CONDITION	MIN.	TYP.	MAX.	UNIT
Output voltage	V _O (V _{SH})		4.75	5.0	5.25	V

•VSH AMPLIFIER

PARAMETER	SYMBOL	TEST CONDITION	MIN.	TYP.	MAX.	UNIT
Input high-level voltage	V _{IH} (VSH)		3.5	4.2	V ⁺	V
Input low-level voltage	V _{IL} (VSH)		0	0.8	1.0	V
Hysteresis	ΔV_{IN} (VSH)		1.0	1.3	1.6	V
Pull-Up resistance	R _U (VSH)		60	80	100	k Ω

■ SPEED DISCRIMINATOR COUNT TABLE

N1	N2	NUMBER OF COUNTS
High or Open	High or Open	128
High or Open	Low	512
Low	High or Open	256
Low	Low	1024

■ THREE PHASE LOGIC TRUTH TABLE

	F/R=L			F/R=H			OUTPUTS	
	H 1	H 2	H 3	H 1	H 2	H 3	Source	Sink
1	H	L	H	L	H	L	VH	UL
2	H	L	L	L	H	H	WH	UL
3	H	H	L	L	L	H	WH	VL
4	L	H	L	H	L	H	UH	VL
5	L	H	H	H	L	L	UH	WL
6	L	L	H	H	H	L	VH	WL

■ S/S TERMINAL

High or Open	Stop
Low	Start

■ BRAKE TERMINAL

High or Open	Brake
Low	Release

NJW4302

■ TYPICAL APPLICATION

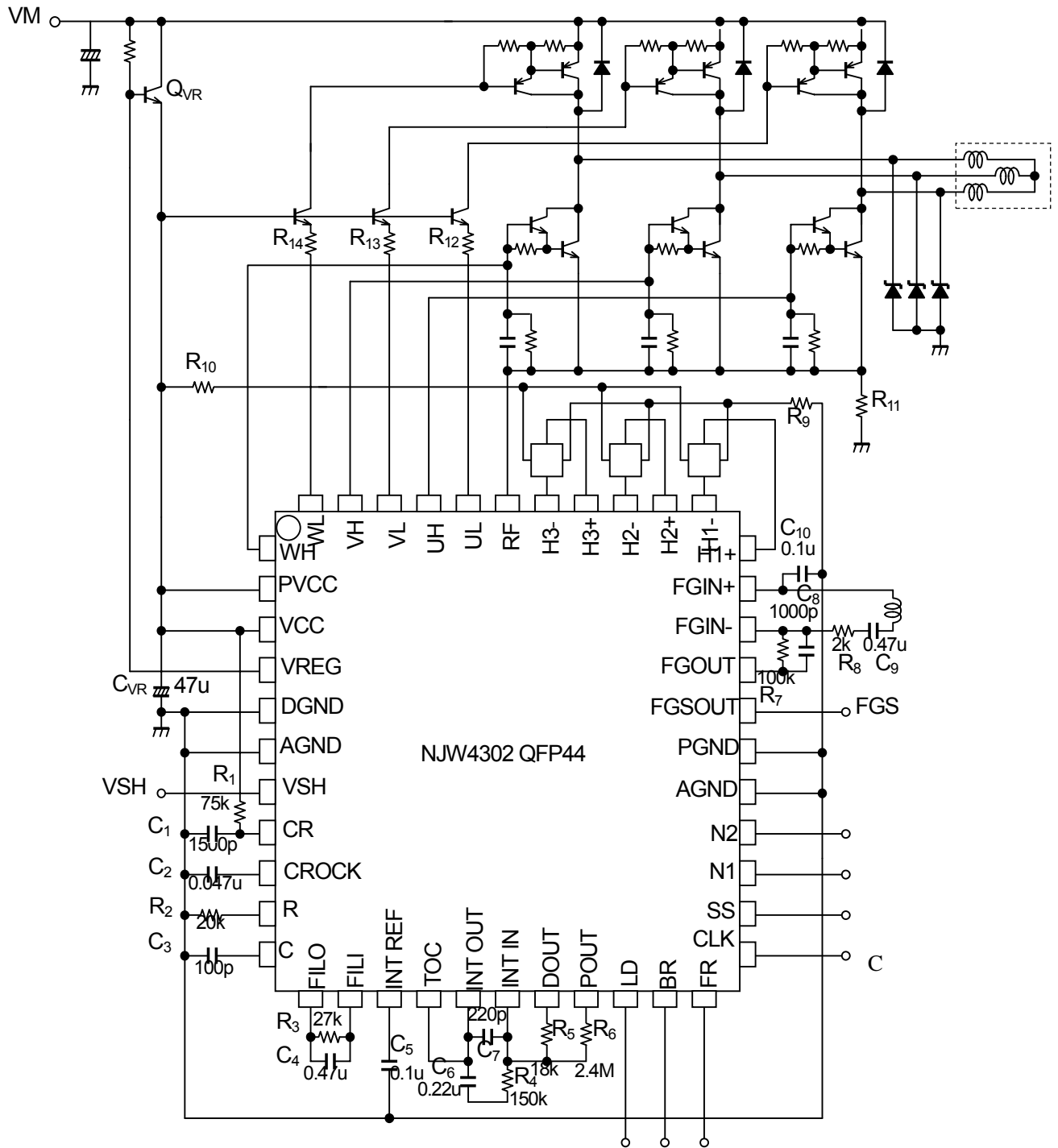

■ TYPICAL CHARACTERISTICS

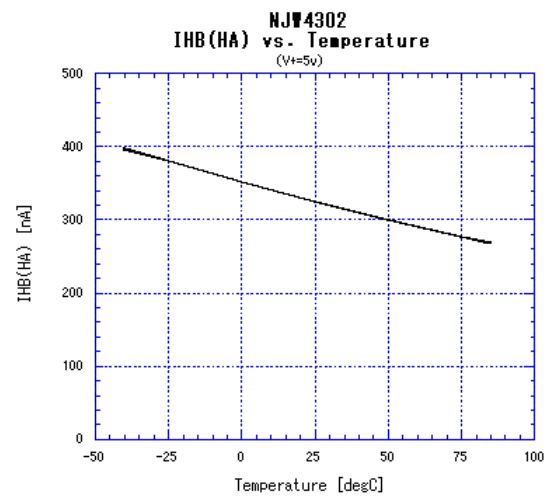
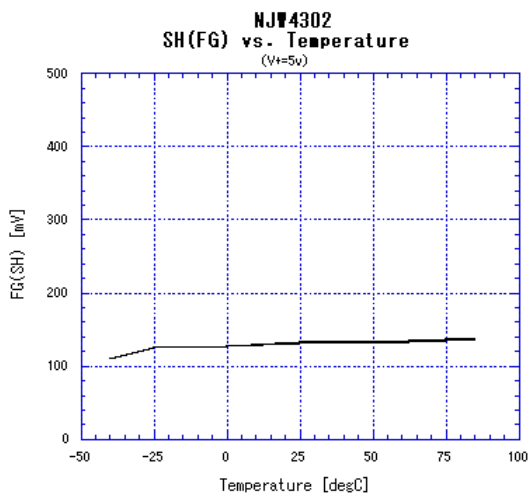
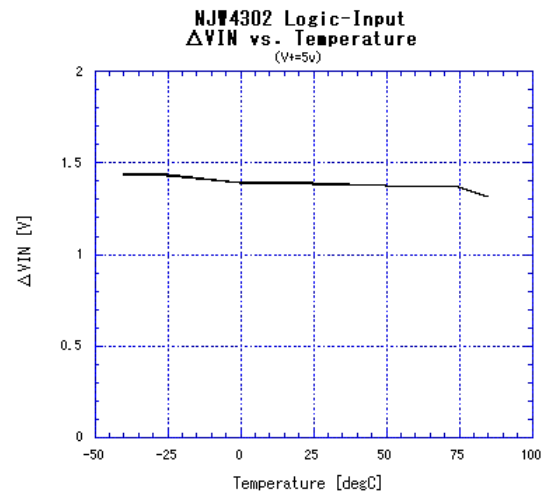
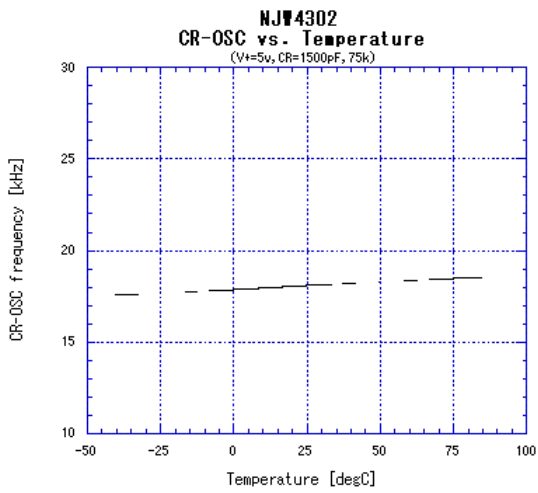
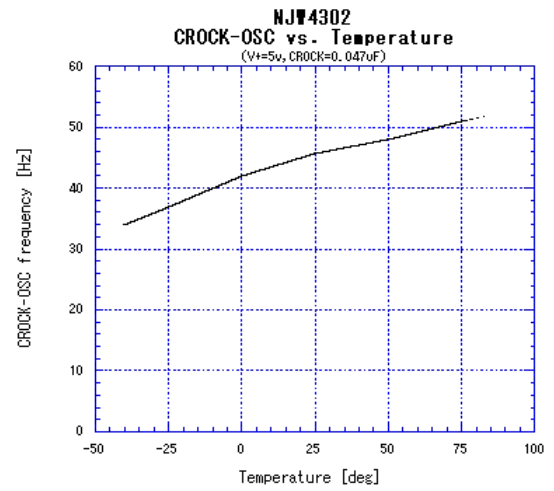
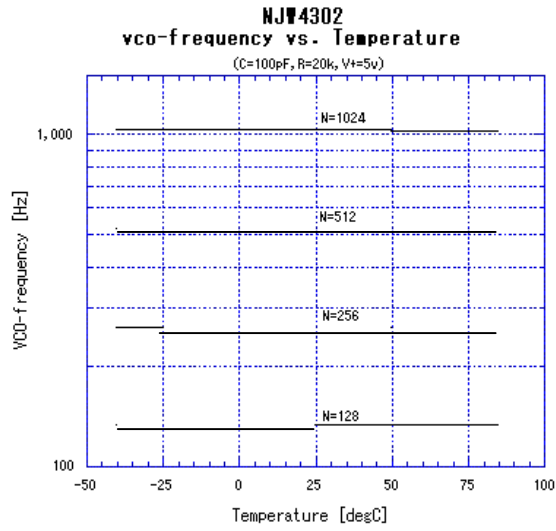

TYPICAL CHARACTERISTICS

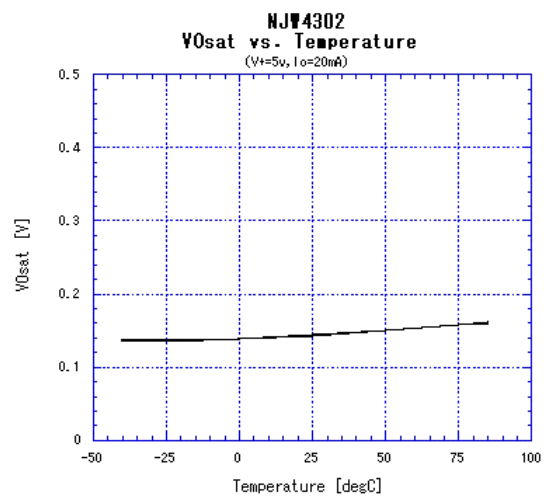
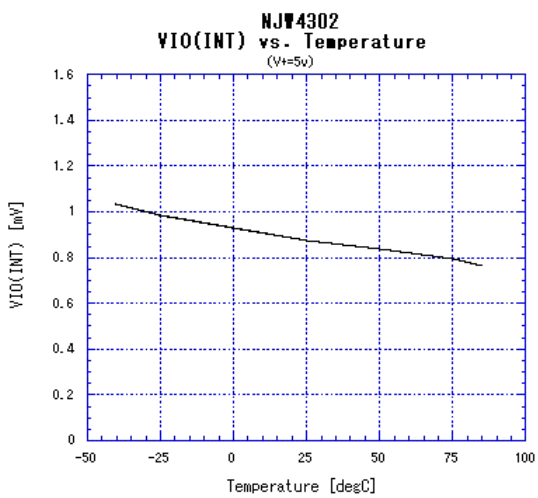
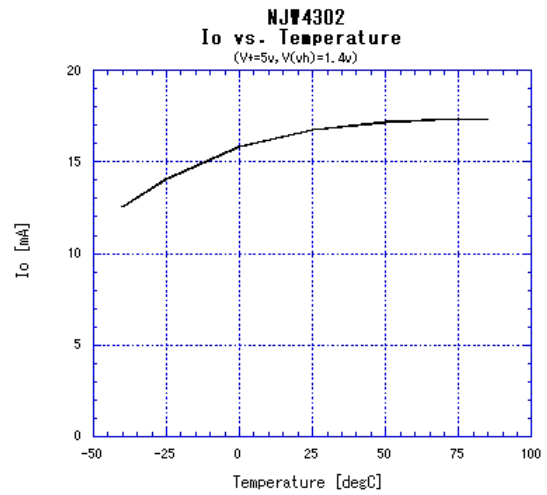
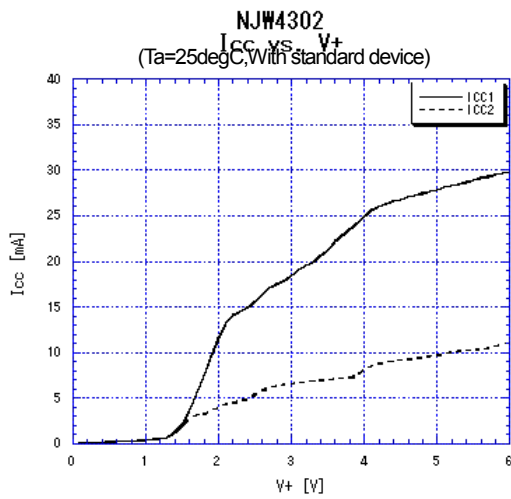
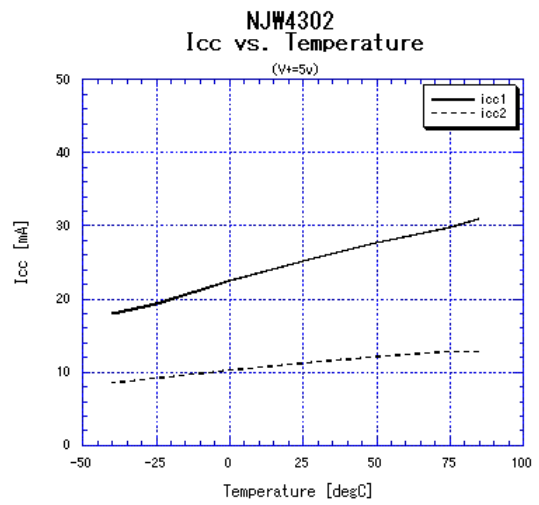
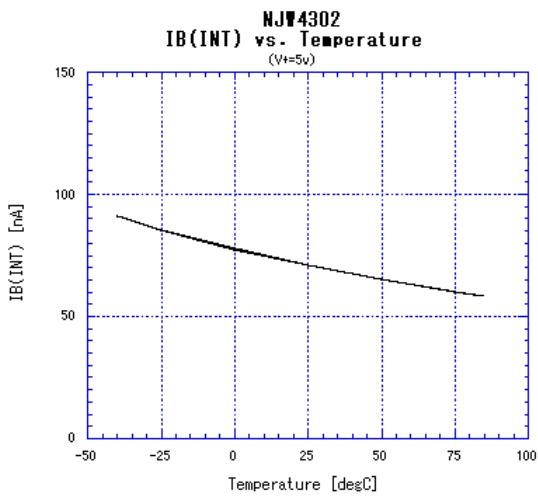

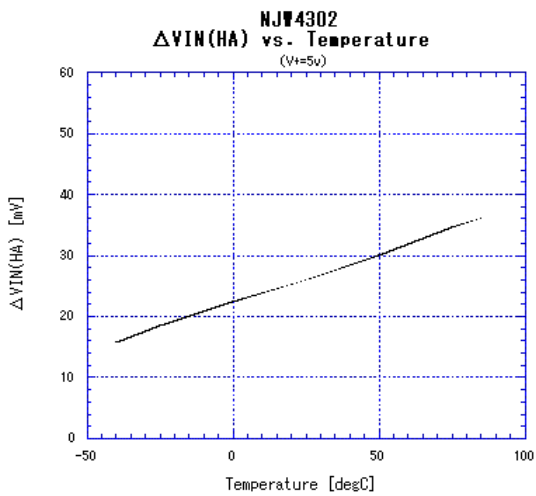

APPLICATION NOTE

•FG Amplifier

FG Amplifier consists of input differential amplifier and output Schmitt-trigger comparator. Input amplifier is constructed as low-pass filter with external resistors and capacitors to reduce noise. The amplifier output level should be over 250mVp-p to adjust gain by external resistors, due to hysteresis of Schmitt-trigger comparator.

FG+ input is biased internally to the half level of V_{cc} . This DC bias voltage is also used to RESET the internal logic circuit. For stable RESET operation, it a capacitor, requires a 0.1 μ F capacitor connected to FG+ terminal. RESET is enable a during 0V to 1.25V of the voltage at the FG+.

FG Sensor Amplifier Application Circuit

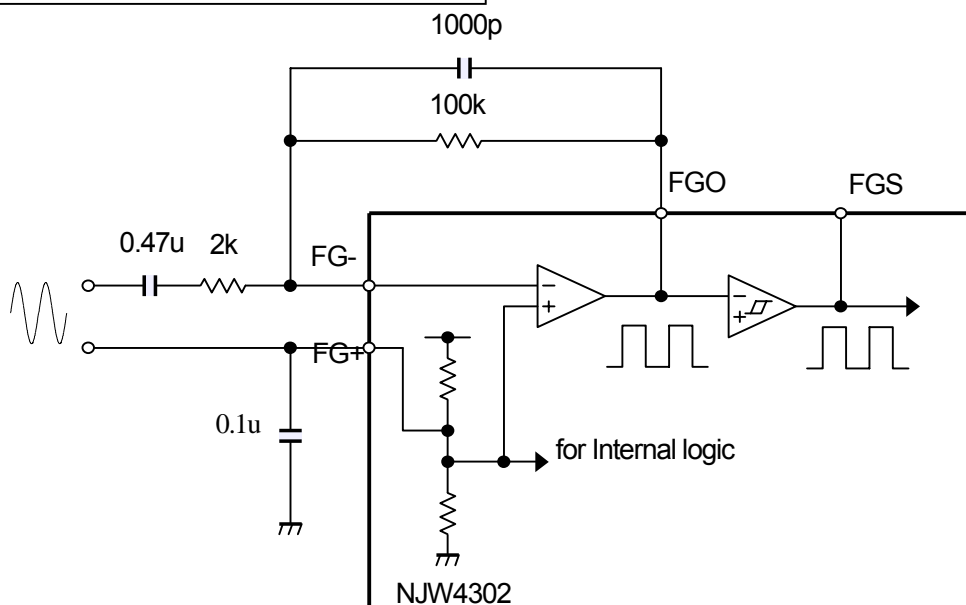

NJW4302

- **FG interfaz for logic output device**

The circuit below is a FG interface for logic output device (i.e. Hall IC and optical encoder). Two external resistors are required to adjust the input voltage within the common mode input voltage range, 0 to Vcc-1.5V.

FG interface for logic level input

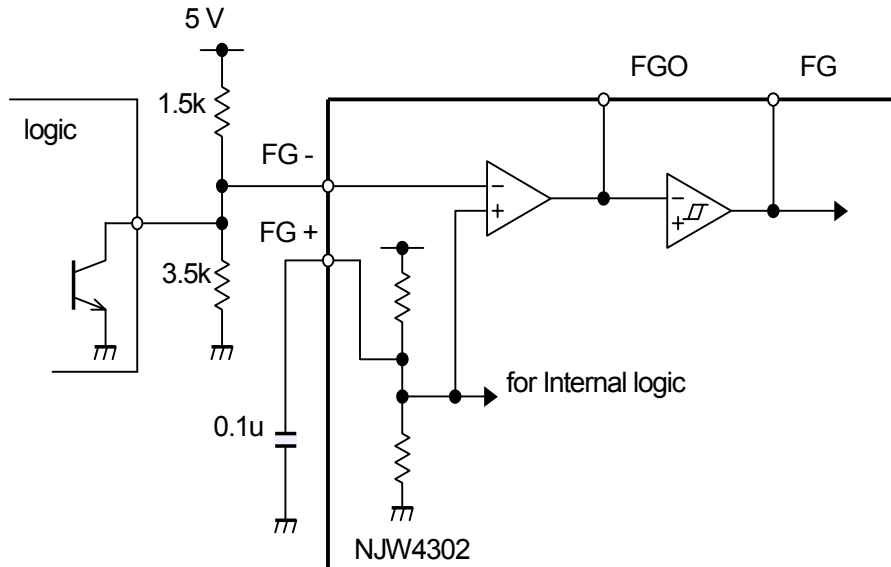

- **Power supply generating from Vref**

To supply for NJM4302, Hall sensor and Power stage, QR1 should have 100mA current capacity. It needs 47 microfarad capacitor on V+ of NJW4302 for ripple filtering.

- **Hall sensor biasing**

Hall biasing is determined by Hall signal amplitude. Hall signal amplitude must be larger than input sensitivity of NJW4302.

- **FG Input**

Internal FG Amplifier is a differential amplifier which inputs and output are pin-outed. The DC gain of this amplifier, A_{FG} , is:

$$A_{FG} = \frac{R7}{R8}$$

C8 is for noise reduction, C9 is for DC cut. Typical value of C10 is 0.1 microfarad. The inductor symbol connected FGIN is FG sensing copper pattern on PC board.

- **Power supply generating from Vref**

To supply for NJM4302, Hall sensor and Power stage, QR1 should have 100mA current capacity. It needs 47 microfarad capacitor on V+ of NJW4302 for ripple filtering.

- **Hall sensor biasing**

Hall biasing is determined by Hall signal amplitude. Hall signal amplitude must be larger than input sensitivity of NJW4302.

• FG Input

Internal FG Amplifier is a differential amplifier and both inputs and output are connected to the pin. The DC gain of this amplifier, A_{FG} , is:

$$A_{FG} = \frac{R7}{R8}$$

C8 is for compensation or noise reduction, C9 is for DC cut. Typical value of C10 is 0.1 microfarad. The inductor symbol connected FGIN is FG sensing copper pattern on PC board.

• PWM Frequency

PWM clock generates by CR oscillator. The frequency is:

$$f_{PWM} = \frac{1}{0.48 \cdot R1 \cdot C1}$$

In fig.x*, f_{PWM} is about 19kHz. If f_{PWM} is about 20kHz, it could reduce audible noise.

• Variable range of VCO frequency

VCO frequency in typical value is recommend 160kHz to 1MHz. External constants is:

$$R2 = 20k \text{ ohm}, \quad C3 = 100pF, \quad R3 = 27k \text{ ohm}, \quad C4 = 0.47 \text{ uF}$$

If it can not be settled into this range, change the division of speed discriminator.

• Detecting time of rock protection

Detecting time is settled by C2 as follow:

$$t_{ROCK} = 66 \cdot C2$$

In fig.x*, t_{rock} is about 3.1 sec.

• Integration Amplifier

Both speed discriminator output and PLL output should be mixed via two resistors before input to INTIN of Integration Amplifier. Mixing resistor, Timing resistors and capacitors are necessary for good system operation. C6 is need for non-polar type capacitor for good stability.

• Upper power transistor

To reduce ripple of power line, Upper output transistor is connect NJM4302 via common-base NPN transistors. Minimum output current is 12mA, it is able to drive 1A class transistor. If more current is needed, change the output transistor to Darlington type. Re-circulating diodes is needed on between collector and emitter of output transistor.

• Lower power transistor

Lower output could drive external power transistor directly to about 1.5A. If more current is needed, change the output transistor to Darlington type. The resistor connected between base and emitter of power transistor is necessary on PWM operation for sharp cut-off of power transistor. When your system have any noise, attach a capacitor in parallel the resistor.

Re-circulating diodes is needed on between collector and emitter of output transistor. R11 is a current sensing resistor and settled by following:

$$R11 = \frac{V_{RE}}{I_o}$$

When VRF is sensing voltage, I_o is sensing current. Take care of power dissipation of R11, also.

- **Recirculation Diodes**

Recirculation diodes are recommend to use Schottky-barrier type. Forward voltage “VF” and reverse returning time “tr” are contributed for power dissipation.

[CAUTION]
The specifications on this databook are only given for information , without any guarantee as regards either mistakes or omissions. The application circuits in this databook are described only to show representative usages of the product and not intended for the guarantee or permission of any right including the industrial rights.