

DUAL H BRIDGE DRIVER

GENERAL DESCRIPTION

The NJW4371 is a general purpose dual H Bridge driver IC. It consists of a pair of Nch DMOS H bridges, gate driving charge pump circuit, thermal shut down and UVLO circuit. Each H bridge can individually be controlled with TTL/CMOS compatible signal. Therefore, it is applicable for a wide range of applications such as driving a two phase stepping motor, two DC brushless motors, solenoids, lamps and other high voltage switching needs using micro controller.

PACKAGE OUTLINE

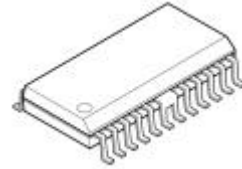

NJW4371E3

FEATURES

- Wide Voltage Range $V_{MM}=10$ to $27V$
- Low ON Resistance $R_{ON}=1.65\Omega$ typ. @ $I_o=\pm 1000mA$
- Low Quiescent Current $I_{MM}=10mA$ typ.
- PWM Control Available
- Under Voltage Lock Out (UVLO)
- Thermal Shutdown Circuit
- BCD Process Technology
- Package Outline EMP24

PIN CONFIGURATIONS

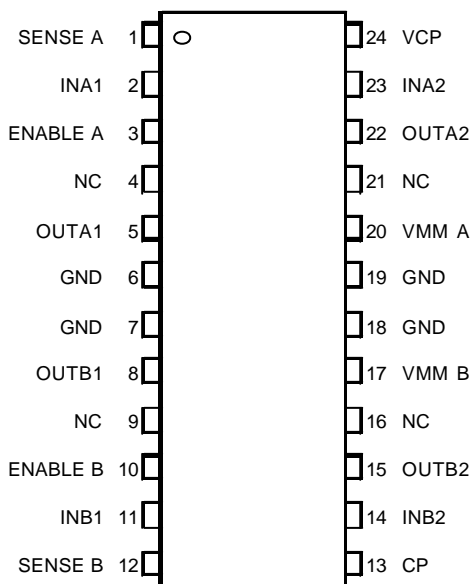

ABSOLUTE MAXIMUM RATINGS

(Ta=25°C)

PARAMETER	RATINGS	SYMBOL (unit)	NOTE
Maximum supply voltage	31	V _S (V)	
Charge pump output voltage	40	V _{CP} (V)	
Output current	0.8	I _O (A)	
Output current (peak)	1.5	I _O (A)	
Operating temperature	-40 ~ +85	T _{opr} (°C)	
Storage temperature	-50 ~ +150	T _{stg} (°C)	
Total power dissipation (EMP)	5.0	P _D (W)	T _{GND} =25°C
	2.0		T _{GND} =125°C

OPERATING CONDITIONS

(Ta=25°C)

PARAMETER	SYMBOL	TEST CONDITION	MIN.	TYP.	MAX.	UNIT
Supply voltage	V _{MM}		10	-	27	V
Junction temperature range	T _j		-40	-	125	°C
Output current	I _O		-	-	0.7	A

ELECTRICAL CHARACTERISTICS

(V_{MM}=24V, Ta=25°C)

PARAMETER	SYMBOL	TEST CONDITION	MIN.	TYP.	MAX.	UNIT
□ GENERAL						
Quiescent current	I _{MM}	INA1=INB1=H, INA2=INB2=L	-	10	15	mA
Under voltage lockout	UVLO		6.3	6.8	7.3	V
Hysteresis voltage	dUVLO		0.25	0.35	0.45	V
Thermal shutdown	T _{SD}		-	180	-	°C
Thermal shutdown hysteresis	T _{HYS}		-	50	-	°C
□ LOGIC						
Input high voltage	V _{IH}		2	-	-	V
Input low voltage	V _{IL}		-	-	0.8	V
H level Input current	I _{IH}	V _i =2.0V	-	-	1	μA
L level input current	I _{IL}	V _i =0.8V	-1	-	-	μA
□ CHARGE PUMP						
CP output voltage	V _{CP}	C _{CP} =10nF, C _{vcP} =100nF	-	V _{MM} +8	-	V
Oscillation frequency	f _{osc}	C _{CP} =10nF, C _{vcP} =100nF	-	500	-	kHz
□ OUTPUT						
Output ON resistance	R _{ONH}	I _O = +1000mA	-	0.85	1.35	Ω
	R _{ONL}	I _O = -1000mA	-	0.80	1.30	
Leak current	I _{Leak}	ENABLE=L	-	-	0.5	mA
Dead recovery time	t _d		-	500	-	ns
Delay time	t _{pd}		-	200	-	ns

TRUTHTABLE

INPUT (L=Low,H=High,X=Don't care)			OUTPUT (H=Source,L=Sink)		OUTPUT mode
ENABLE A=H ENABLE B=H	INA1 INB1	INA2 INB2	OUTA1 OUTB1	OUTA2 OUTB2	
	L	L	L	L	short break 1
	L	H	L	H	CW
	H	L	H	L	CCW
	H	H	H	H	short break 2
ENABLE A=L ENABLE B=L	X	X	All Transistor turend OFF		

TIMING CONDITION

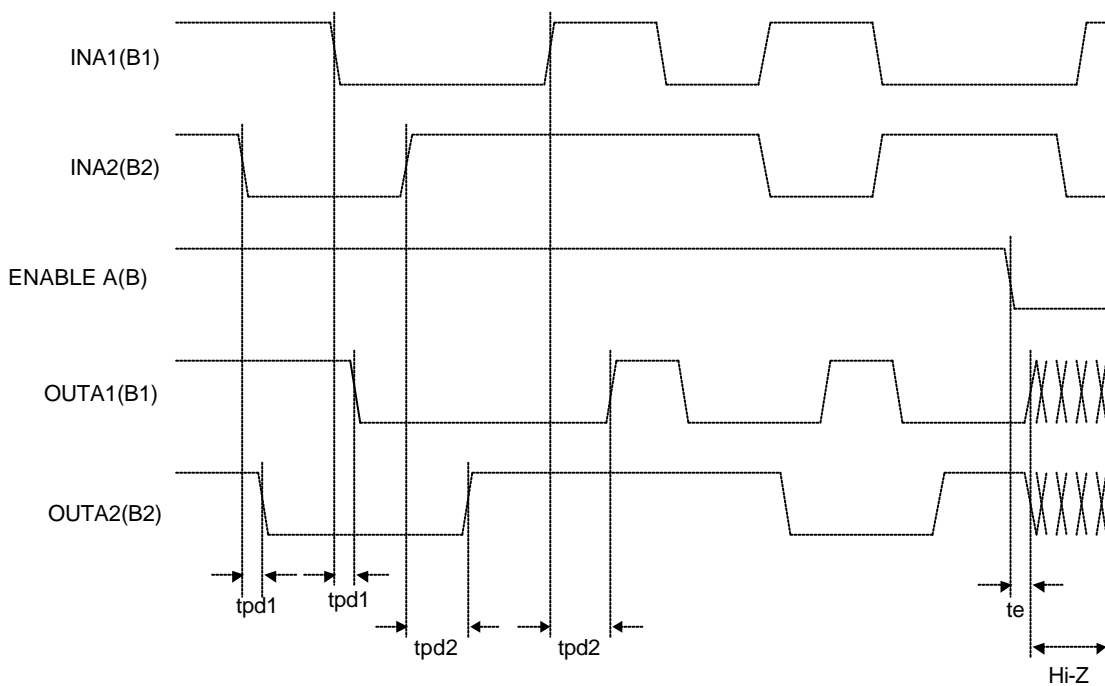

BLOCK DIAGLAM

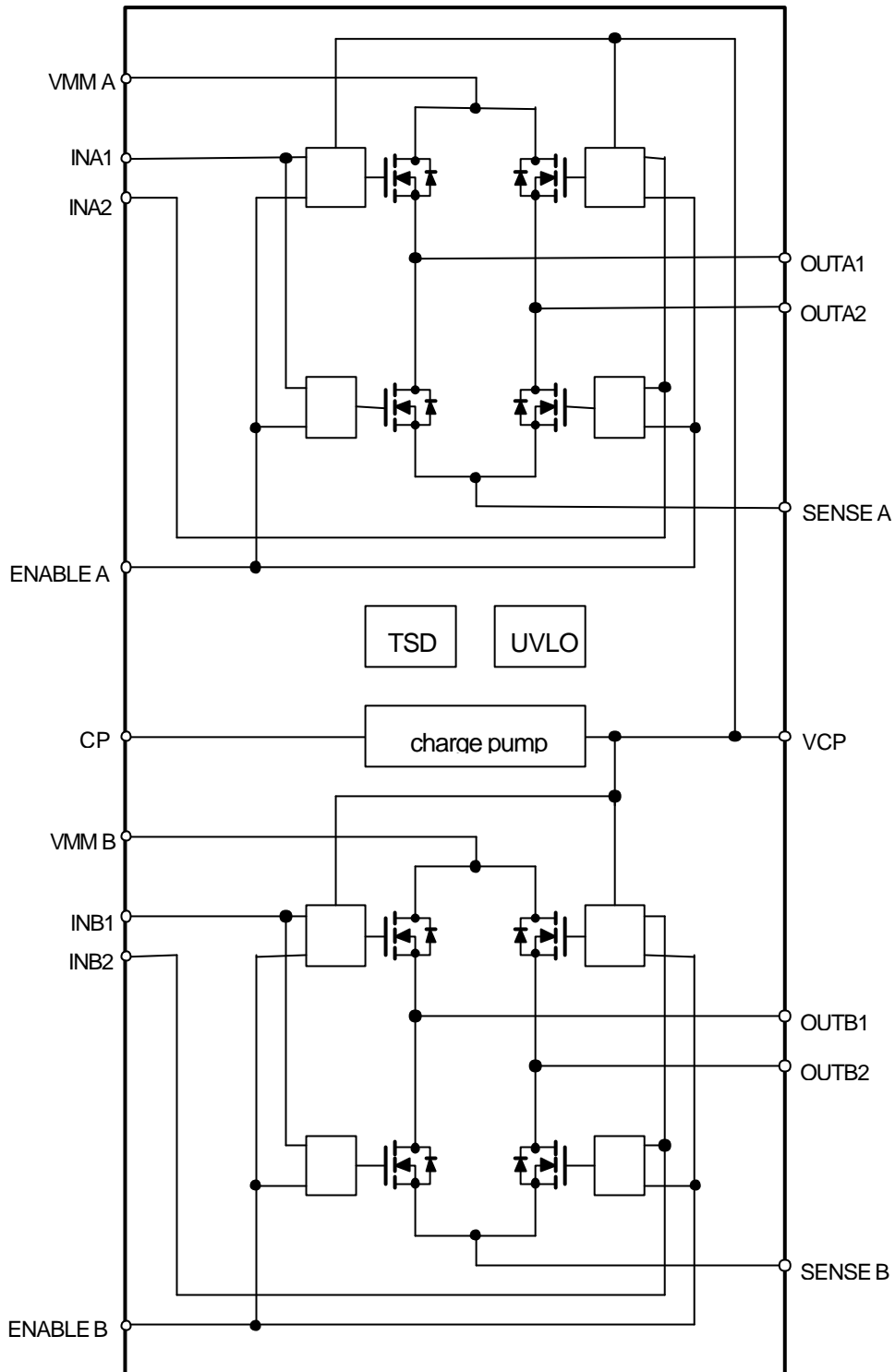

APPLICATION CIRCUIT

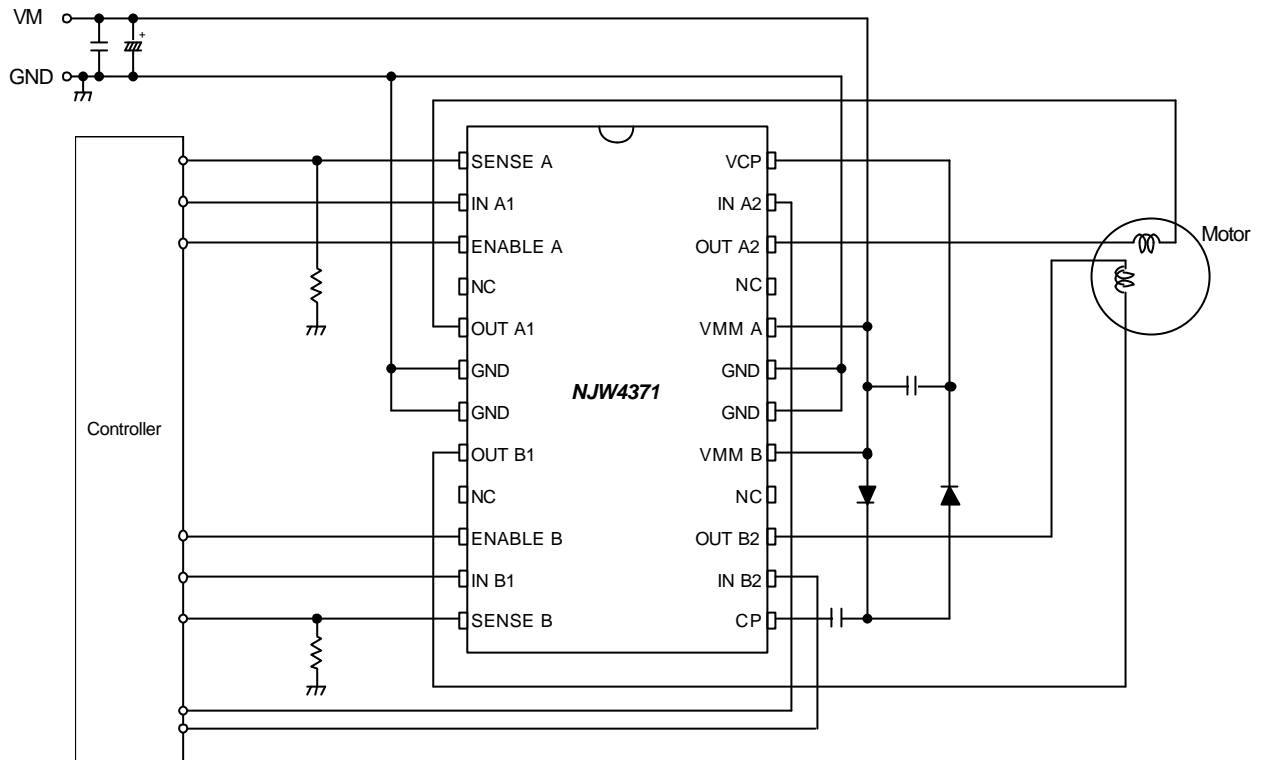

TYPICAL CHARACTERISTICS

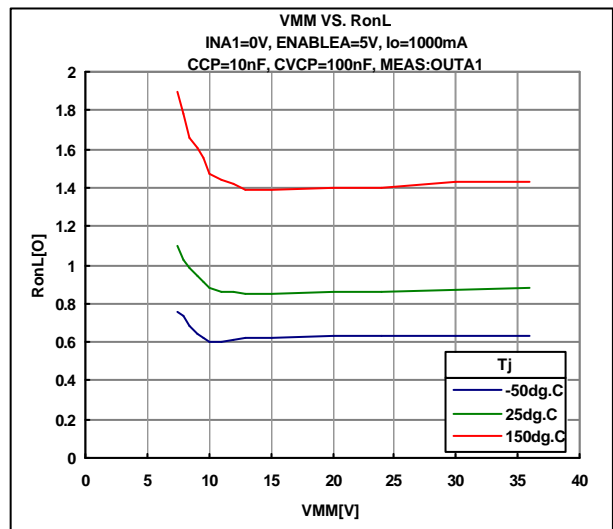
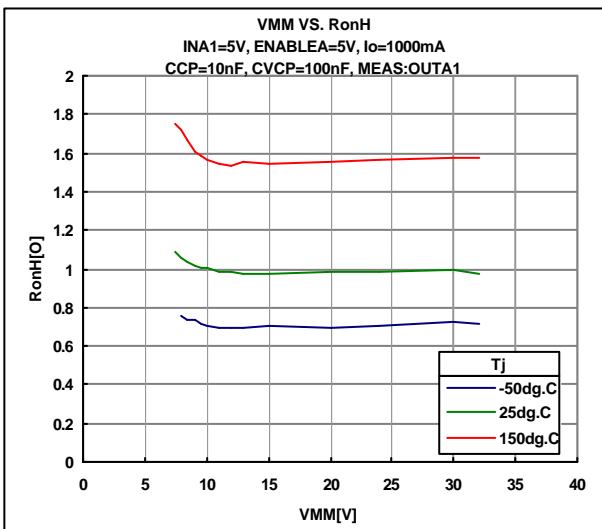
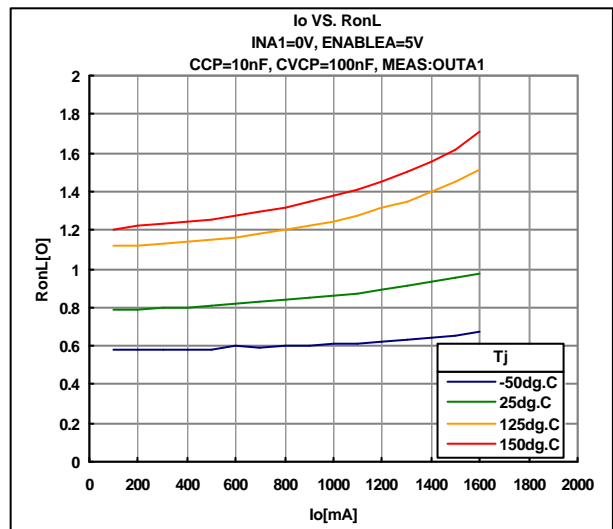
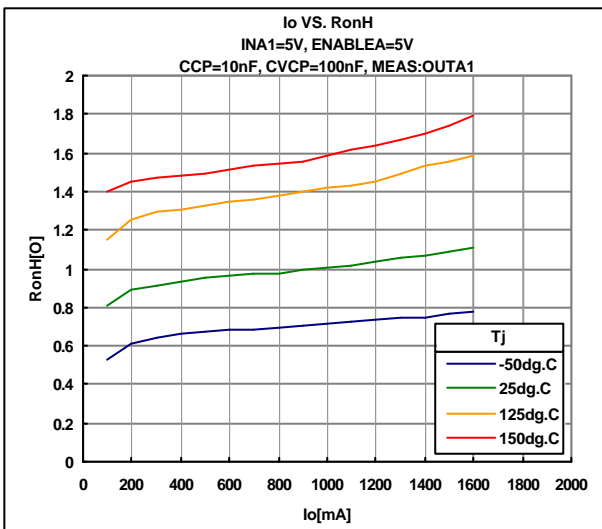
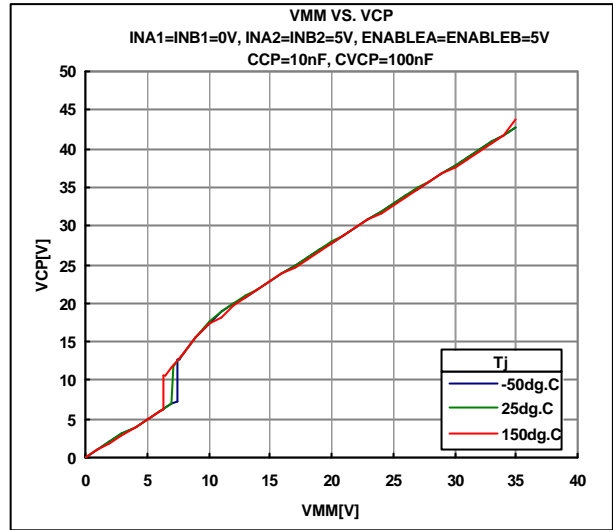
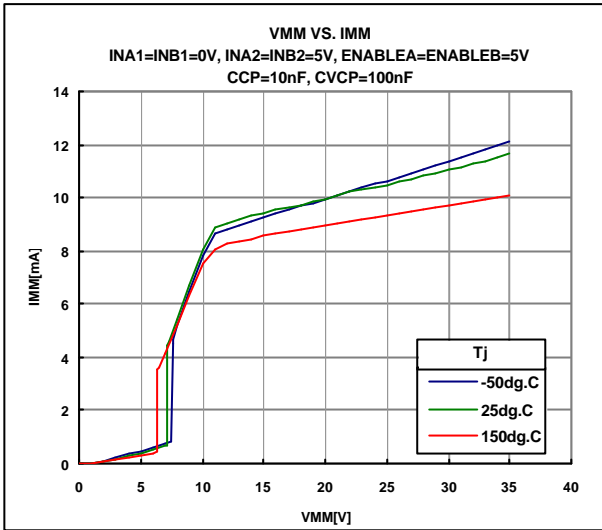

[CAUTION]

The specifications on this databook are only given for information, without any guarantee as regards either mistakes or omissions. The application circuits in this databook are described only to show representative usages of the product and not intended for the guarantee or permission of any right including the industrial rights.