

**NEC** NEC LCD Technologies, Ltd.

## TFT COLOR LCD MODULE

**NL128102BC29-01B**

**NL128102BC29-01C**

**48.0 cm (19.0 Type)**

**SXGA**

**LVDS interface (2port)**

**DATA SHEET**

**DOD-PD-0744 (1st edition)**

**All information is subject to change without notice.  
Please confirm the sales representative before  
starting to design your system.**

## INTRODUCTION

No part of this document shall be copied in any form or by any means without the prior written consent of NEC LCD Technologies, Ltd. (hereinafter called "NEC").

NEC does not assume any liability for infringement of patents, copyrights or other intellectual property rights of third parties by or arising from use of a product described herein or any other liability arising from use of such application. No license, express, implied or otherwise, is granted under any patents, copyrights or other intellectual property rights of NEC or of others.

While NEC has been making continuous effort to enhance the reliability of its products, the possibility of failures cannot be eliminated entirely. To minimize risks of damage to property or injury to person arising from a failure in an NEC product, customers must incorporate sufficient safety measures in their design, such as redundancy, fire-containment and anti-failure features.

NEC products are classified into the following three quality grades:

**"Standard", "Special", "Specific"**

The **"Specific"** quality grade applies only to applications developed based on a customer designated "quality assurance program" for a specific application. The recommended applications of a product depend on its quality grade, as indicated below. Customers must check the quality grade of each application before using it in a particular application.

**Standard:** Computers, office equipment, communications equipment, test and measurement equipment, audio and visual equipment, home electronic appliances, machine tools, personal electronic equipment and industrial robots

**Special:** Transportation equipment (automobiles, trains, ships, etc.), traffic control systems, anti-disaster systems, anti-crime systems, safety equipment and medical equipment (not specifically designed for life support)

**Specific:** Military systems, aircraft, aerospace equipment, submersible repeaters, nuclear reactor control systems, life support systems (medical equipment, etc.) and any other equipment

The quality grade of this product is **"Standard"** unless otherwise specified in this document. If customers intend to use this product for applications other than those specified for **"Standard"** quality grade, they should contact NEC sales representative in advance.

## CONTENTS

<b>INTRODUCTION .....</b>	<b>2</b>
<b>1. OUTLINE.....</b>	<b>4</b>
1.1 STRUCTURE AND PRINCIPLE.....	4
1.2 APPLICATION.....	4
1.3 FEATURES.....	4
<b>2. GENERAL SPECIFICATIONS .....</b>	<b>5</b>
<b>3. BLOCK DIAGRAM.....</b>	<b>6</b>
<b>4. DETAILED SPECIFICATIONS .....</b>	<b>7</b>
4.1 MECHANICAL SPECIFICATIONS.....	7
4.2 ABSOLUTE MAXIMUM RATINGS .....	7
4.3 ELECTRICAL CHARACTERISTICS.....	8
4.3.1 LCD panel signal processing board .....	8
4.3.2 Backlight lamp.....	9
4.3.3 Power supply voltage ripple.....	10
4.3.4 Fuse.....	10
4.4 POWER SUPPLY VOLTAGE SEQUENCE .....	11
4.5 CONNECTIONS AND FUNCTIONS FOR INTERFACE PINS.....	12
4.5.1 LCD panel signal processing board .....	12
4.5.2 Backlight lamp.....	13
4.5.3 Positions of plugs and socket.....	15
4.6 SELECTION OF LVDS DATA INPUT MAP .....	16
4.6.1 Mode A .....	16
4.6.2 Mode B .....	17
4.7 DISPLAY COLORS AND INPUT DATA SIGNALS .....	18
4.8 DISPLAY POSITION.....	19
4.9 INPUT SIGNAL TIMINGS.....	19
4.9.1 Timing characteristics.....	19
4.9.2 Input signal timing chart.....	20
4.10 OPTICS.....	21
4.10.1 Optical characteristics.....	21
4.10.2 Definition of contrast ratio.....	23
4.10.3 Definition of luminance uniformity .....	23
4.10.4 Definition of response times .....	23
4.10.5 Definition of viewing angles.....	23
<b>5. RELIABILITY TESTS.....</b>	<b>24</b>
<b>6. PRECAUTIONS .....</b>	<b>25</b>
6.1 MEANING OF CAUTION SIGNS .....	25
6.2 CAUTIONS .....	25
6.3 ATTENTIONS .....	25
6.3.1 Handling of the product .....	25
6.3.2 Environment.....	26
6.3.3 Characteristics.....	26
6.3.4 Other .....	26
<b>7. OUTLINE DRAWINGS .....</b>	<b>27</b>
7.1 FRONT VIEW .....	27
7.2 REAR VIEW .....	28

## 1. OUTLINE

### 1.1 STRUCTURE AND PRINCIPLE

Color LCD module NL128102BC29-01B and NL128102BC29-01C are composed of the amorphous silicon thin film transistor liquid crystal display (a-Si TFT LCD) panel structure with driver LSIs for driving the TFT (Thin Film Transistor) array and a backlight.

The a-Si TFT LCD panel structure is injected liquid crystal material into a narrow gap between the TFT array glass substrate and a monochrome-filter glass substrate.

Color (Red, Green, Blue) data signals from a host system (e.g. PC, signal generator, etc.) are modulated into best form for active matrix system by a signal processing board, and sent to the driver LSIs which drive the individual TFT arrays.

The TFT array as an electro-optical switch regulates the amount of transmitted light from the backlight assembly, when it is controlled by data signals. Color images are created by regulating the amount of transmitted light through the TFT array of red, green and blue dots.

### 1.2 APPLICATION

- Monitor for PC

### 1.3 FEATURES

- Ultra-wide viewing angle (Adoption of Super Advanced-Super Fine TFT (SA-SFT))
- Wide color gamut
- High contrast
- LVDS interface
- Selectable LVDS data input map
- Edge light type (without inverter)
- Acquisition product for UL60950-1 1st edition/CSA-C22.2 No.60950-1-03 (File number: E170632)
- Difference between NL128102BC29-01B and NL128102BC29-01C

Item	NL128102BC29-01B	NL128102BC29-01C
Luminance	280cd/m <sup>2</sup> (typ.)	270cd/m <sup>2</sup> (typ.)
White chromaticity	W <sub>x</sub> , W <sub>y</sub> = (0.313, 0.329) (typ.)	W <sub>x</sub> , W <sub>y</sub> = (0.300, 0.315) (typ.)
Cable color of backlight lamps	See " <b>4.5.2 Backlight lamp</b> ".	

## 2. GENERAL SPECIFICATIONS

<b>Display area</b>	376.32 (H) × 301.056 (V) mm	
<b>Diagonal size of display</b>	48.0 cm (19.0 inches)	
<b>Drive system</b>	a-Si TFT active matrix	
<b>Display color</b>	16,777,216 colors	
<b>Pixel</b>	1,280 (H) × 1,024 (V) pixels	
<b>Pixel arrangement</b>	RGB (Red dot, Green dot, Blue dot) vertical stripe	
<b>Dot pitch</b>	0.098 (H) × 0.294 (V) mm	
<b>Pixel pitch</b>	0.294 (H) × 0.294 (V) mm	
<b>Module size</b>	404.2 (W) × 330.0 (H) × 22.0 (D) mm (typ.)	
<b>Weight</b>	2,900 g (typ.)	
<b>Contrast ratio</b>	450:1 (typ.)	
<b>Viewing angle</b>	<i>At the contrast ratio ≥10:1</i> <ul style="list-style-type: none"> <li>• Horizontal: Right side 85° (typ.), Left side 85° (typ.)</li> <li>• Vertical: Up side 85° (typ.), Down side 85° (typ.)</li> </ul>	
<b>Designed viewing direction</b>	Viewing angle with optimum grayscale ( $\gamma=2.2$ ): normal axis	
<b>Polarizer surface</b>	Antiglare	
<b>Polarizer pencil-hardness</b>	2H (min.) [by JIS K5400]	
<b>Color gamut</b>	<i>At LCD panel center</i> 72 % (typ.) [against NTSC color space]	
<b>Response time</b>	<i>Ton+Toff (10%←→90%)</i> 20 ms (typ.)	
<b>Luminance</b>	NL128102BC29-01B	<i>At IBL=6.0mArms / lamp</i> 280cd/m <sup>2</sup> (typ.)
	NL128102BC29-01C	<i>At IBL=6.0mArms / lamp</i> 270cd/m <sup>2</sup> (typ.)
<b>White chromaticity</b>	NL128102BC29-01B	W <sub>x</sub> , W <sub>y</sub> = (0.313, 0.329) (typ.)
	NL128102BC29-01C	W <sub>x</sub> , W <sub>y</sub> = (0.300, 0.315) (typ.)
<b>Signal system</b>	LVDS 2 port 8bit digital signals for data of RGB colors, Dot clock (CLK), Data enable (DE)	
<b>Power supply voltage</b>	LCD panel signal processing board: 5.0V	
<b>Backlight</b>	Edge light type: 6 cold cathode fluorescent lamps (without inverter)	
<b>Power consumption</b>	<i>At IBL=6.0mArms / lamp and checkered flag pattern</i> 26.8 W (typ., Power dissipation of the inverter is not included.)	

**3. BLOCK DIAGRAM**

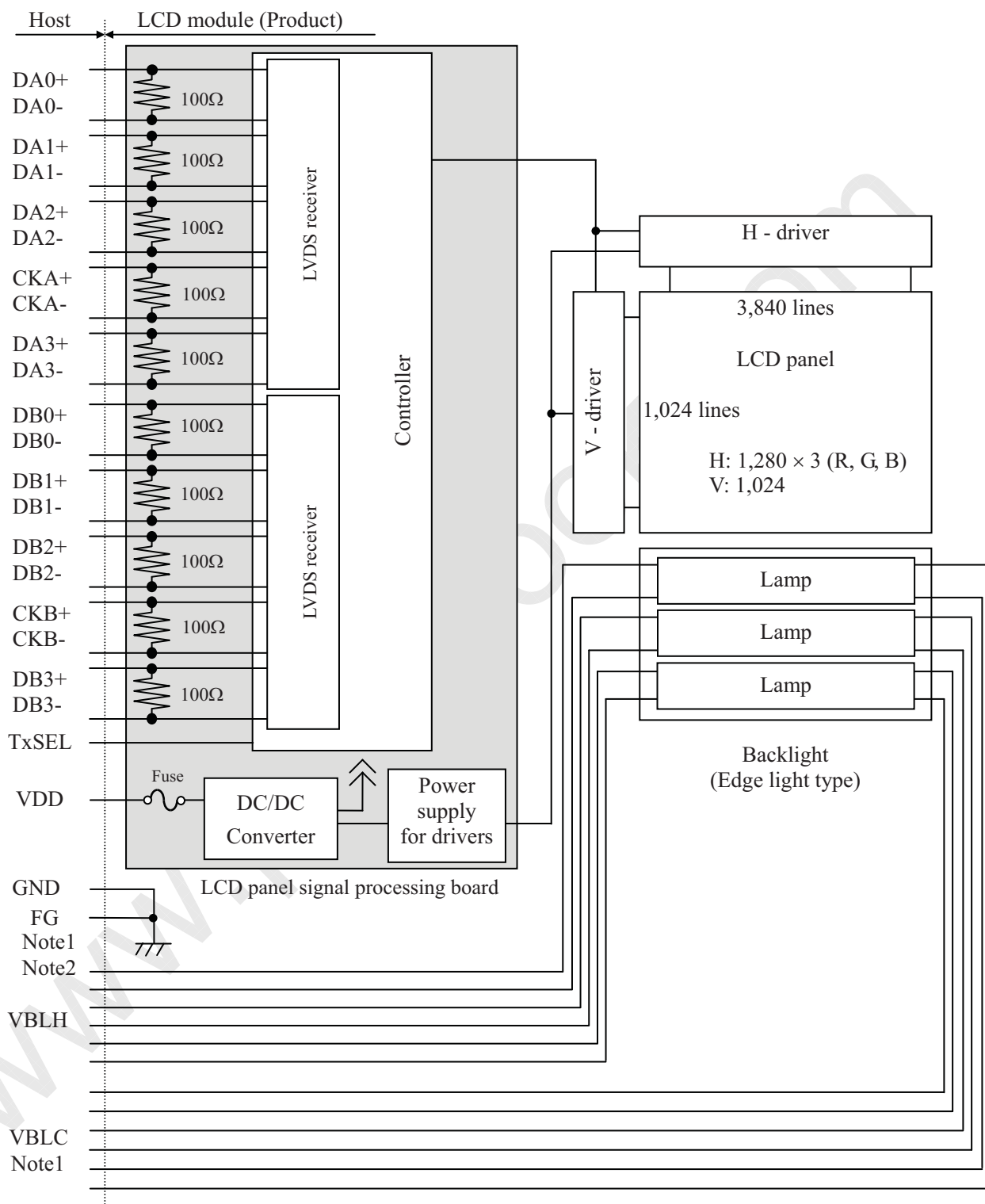

Note1: Connections between GND (Signal ground), FG (Frame ground) and VBLC (Lamp low voltage terminal) in the LCD module

GND - FG	Connected
GND - VBLC	Not connected
FG - VBLC	Not connected

Note2: GND and FG must be connected to customer equipment's ground, and it is recommended that GND, FG and customer inverter ground are connected together in customer equipment.

## 4. DETAILED SPECIFICATIONS

## 4.1 MECHANICAL SPECIFICATIONS

Parameter	Specification	Unit
Module size	404.2 ± 0.5 (W) × 330.0 ± 0.5 (H) × 22.0 ± 0.3 (D) Note1	Note2 mm
Display area	376.32 (H) × 301.056 (V)	Note2 mm
Weight	2,900 (typ.), 3,100 (max.)	g

Note1: Excluding lamp cable, cable clamp and projections.

Note2: See "7. OUTLINE DRAWINGS".

## 4.2 ABSOLUTE MAXIMUM RATINGS

Parameter		Symbol	Rating	Unit	Remarks
Power supply voltage	LCD panel signal processing board	VDD	-0.3 to +6.0	V	Ta = 25°C
	Lamp voltage	VBLH	2,000	Vrms	
Input voltage for signals	Display signals Note1	VD	-0.3 to +2.8	V	Ta = 25°C VDD = 5.0V
	Function signal Note2	VF		V	
Storage temperature		Tst	-20 to +60	°C	-
Operating temperature	Front surface	TopF	0 to +55	°C	Note3
	Rear surface	TopR	0 to +60	°C	Note4
Relative humidity Note5	RH	≤ 95	%	Ta ≤ 40°C	
		≤ 85	%	40 < Ta ≤ 50°C	
		≤ 70	%	50 < Ta ≤ 55°C	
Absolute humidity Note5	AH	≤ 73 Note6	g/m <sup>3</sup>	Ta > 55°C	
Operating altitude	-	≤ 4,850	m	0°C ≤ Ta ≤ 55°C	
Storage altitude	-	≤ 13,600	m	-20°C ≤ Ta ≤ 60°C	

Note1: DA0+/-, DA1+/-, DA2+/-, DA3+/-, CKA+/-, DB0+/-, DB1+/-, DB2+/-, DB3+/-, CKB+/-

Note2: TxSEL

Note3: Measured at center of LCD panel surface (including self-heat)

Note4: Measured at center of LCD module's rear shield surface (including self-heat)

Note5: No condensation

Note6: Water amount at Ta = 55°C and RH = 70%

## 4.3 ELECTRICAL CHARACTERISTICS

## 4.3.1 LCD panel signal processing board

(Ta = 25°C)

Parameter	Symbol	min.	typ.	max.	Unit	Remarks	
Power supply voltage	VDD	4.5	5.0	5.5	V	-	
Power supply current	IDD	-	680 Note1	1,400 Note2	mA	at VDD = 5.0V	
Permissible ripple voltage	VRP	-	-	100	mVp-p	for VDD	
Differential input threshold voltage for LVDS receiver	High	VTH	-	-	+100	mV	at VCM=1.2V Note3
	Low	VTL	-100	-	-	mV	
Terminating resistance	RT	-	100	-	Ω	-	
Input voltage for TxSEL signal	High	VFH	High must be Open.			-	TxSEL Note4
	Low	VFL	-	-	0.5	V	
Input current for TxSEL signal	IFL	-80	-	-35	μA		

Note1: Checkered flag pattern [by EIAJ ED-2522]

Note2: Pattern for maximum current

Note3: Common mode voltage for LVDS receiver

Note4: TxSEL is pulled-up in the product. (Pull-up resistance: 50kΩ)



## 4.3.2 Backlight lamp

(Ta=25°C, Note1)

Parameter	Symbol	min.	typ.	max.	Unit	Remarks
Lamp current	IBL	3.5	6.0	7.0	mArms	at IBL=6.0mArms: NL128102BC29-01B 280cd/m <sup>2</sup> NL128102BC29-01C 270cd/m <sup>2</sup> Note3
Lamp voltage	VBLH	-	650	-	Vrms	Note2, Note3
Lamp starting voltage	VS	1,350	-	-	Vrms	Ta = 25°C Note2, Note3
		1,550	-	-	Vrms	Ta = 0°C Note2, Note3
Lamp oscillation frequency	FO	40	48	55	kHz	Note4

Note1: This product consists of 6 backlight lamps, and these specifications are for each lamp.

Note2: The lamp voltage cycle between lamps should be kept on a same phase. "VS" and "VBLH" are the voltage value between low voltage side (Cold) and high voltage side (Hot).

Note3: The asymmetric ratio of working waveform for lamps (Power supply voltage peak ratio, power supply current peak ratio and waveform space ratio) should be less than 5 % (See the following figure.). If the waveform is asymmetric, DC (Direct current) element apply into the lamp. In this case, a lamp lifetime may be shortened, because a distribution of a lamp enclosure substance inclines toward one side between low voltage terminal (Cold terminal) and high voltage terminal (Hot terminal). When designing the inverter, evaluate asymmetric of lamp working waveform sufficiently.

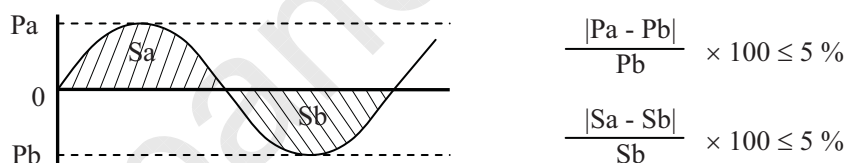

Pa: Supply voltage/current peak for positive, Pb: Supply voltage/current peak for negative  
Sa: Waveform space for positive part, Sb: Waveform space for negative part

Note4: In case "FO" is not the recommended value, beat noise may display on the screen, because of interference between "FO" and "1/th". Recommended value of "FO" is as following.

$$FO = \frac{1}{4} \times \frac{1}{th} \times (2n-1)$$

th: Horizontal cycle (See "4.9.1 Timing characteristics".)

n: Natural number (1, 2, 3 .....)

Note5: Method of lamp cable installation may invite fluctuation of lamp current and voltage or asymmetric of lamp working waveform. When designing method of lamp cable installation, evaluate the fluctuation of lamp current, voltage and working waveform sufficiently.

## 4.3.3 Power supply voltage ripple

This product works, even if the ripple voltage levels are beyond the permissible values as following the table, but there might be noise on the display image.

Power supply voltage		Ripple voltage (Measure at input terminal of power supply)	Unit
VDD	5.0V	≤ 100	mVp-p

Note1: The permissible ripple voltage includes spike noise.

## 4.3.4 Fuse

Parameter	Fuse		Rating	Fusing current	Remarks
	Type	Supplier			
VDD	KAB2402 402	Matsuo Electric Co., Ltd.	4.0 A	8 A, 1min. max.	Note1
			24 V		

Note1: The power supply capacity should be more than the fusing current. If the power supply capacity is less than the fusing current, the fuse may not blow for a short time, and then nasty smell, smoking and so on may occur.

## 4.4 POWER SUPPLY VOLTAGE SEQUENCE

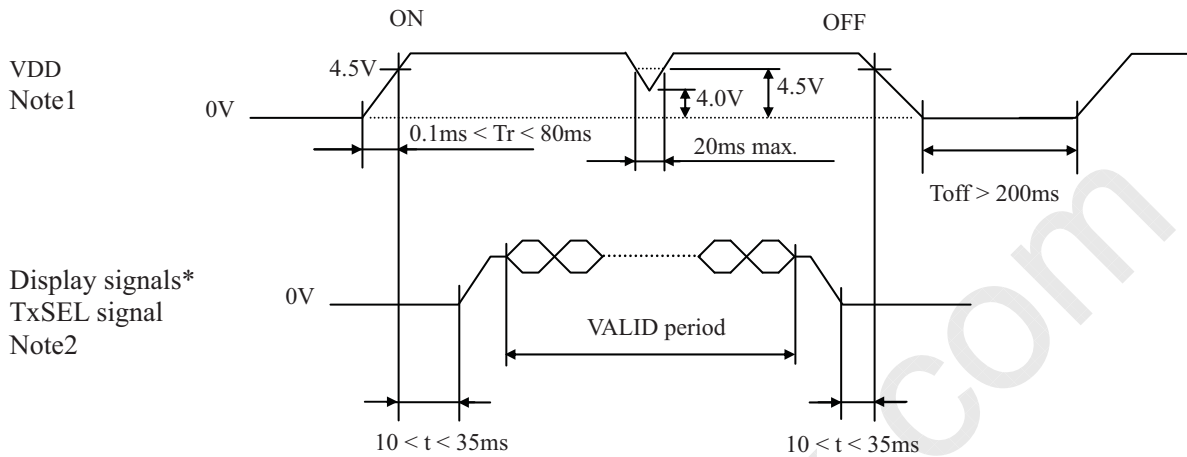

\* These signals should be measured at the terminal of 100Ω resistance.

Note1: In terms of voltage variation (voltage drop) while VDD rising edge is below 4.5V, a protection circuit may work, and then this product may not work.

Note2: Display signals (DA0+/-, DA1+/-, DA2+/-, DA3+/-, CKA+/-, DB0+/-, DB1+/-, DB2+/-, DB3+/-, CKB+/-) and TxSEL signal must be "0" voltage, exclude the VALID period (See above sequence diagram). If these signals are higher than 0.3V, the internal circuit is damaged. If some of display and function signals of this product are cut while this product is working, even if the signal input to it once again, it might not work normally. If customer stops the display and function signals, they should be cut VDD.

Note3: VDD should be 4.5V or more while VDD ON period.

Note4: The backlight power supply voltage should be inputted within the valid period of display and function signals, in order to avoid unstable data display.

## 4.5 CONNECTIONS AND FUNCTIONS FOR INTERFACE PINS

## 4.5.1 LCD panel signal processing board

CN1 socket (LCD module side): FI-X30SSL-HF (Japan Aviation Electronics Industry Limited (JAE))

Adaptable plug: FI-X30C series/ FI-X30H series/ FI-X30M series

(Japan Aviation Electronics Industry Limited (JAE))

Pin No.	Symbol	Signal	Remarks
1	DA0-	Odd pixel data 0	Note1
2	DA0+		
3	DA1-	Odd pixel data 1	Note1
4	DA1+		
5	DA2-	Odd pixel data 2	Note1
6	DA2+		
7	GND	Ground	Note2
8	CKA-	Odd pixel clock	Note1
9	CKA+		
10	DA3-	Odd pixel data 3	Note1
11	DA3+		
12	DB0-	Even pixel data 0	Note1
13	DB0+		
14	GND	Ground	Note2
15	DB1-	Even pixel data 1	Note1
16	DB1+		
17	GND	Ground	Note2
18	DB2-	Even pixel data 2	Note1
19	DB2+		
20	CKB-	Even pixel clock	Note1
21	CKB+		
22	DB3-	Even pixel data 3	Note1
23	DB3+		
24	GND	Ground	Note2
25	TxSEL	Selection of LVDS data input map	Open: Mode A Low: Mode B Note3, Note4
26	RSVD	-	Keep this pin Open.
27	N.C.	-	Keep this pin Open.
28	VDD	Power supply	Note2
29			
30			

Note1: Twist pair wires with 100Ω (Characteristic impedance) should be connected between LCD panel signal processing board and LVDS transmitter.

Note2: All GND and VDD terminals should be used without any non-connected lines.

Note3: TxSEL is pulled-up in the product. (Pull-up resistance: 50kΩ)

Note4: See "4.6 SELECTION OF LVDS DATA INPUT MAP".

## 4.5.2 Backlight lamp

**Attention: VBLH and VBLC must be connected correctly. If customer connects wrongly, customer will be hurt and the module will be broken.**

## (1) NL128102BC29-01B

CN201 plug (LCD module side): BHSR-02VS-1 (J.S.T Mfg. Co., Ltd.)

Adaptable socket: SM02B-BHSS-1-TB (J.S.T Mfg. Co., Ltd.)

Pin No.	Symbol	Signal	Remarks
1	VBLH	High voltage (Hot)	Cable color: Pink
2	VBLC	Low voltage (Cold)	Cable color: Gray

CN202 plug (LCD module side): BHSR-02VS-1 (J.S.T Mfg. Co., Ltd.)

Adaptable socket: SM02B-BHSS-1-TB (J.S.T Mfg. Co., Ltd.)

Pin No.	Symbol	Signal	Remarks
1	VBLH	High voltage (Hot)	Cable color: White
2	VBLC	Low voltage (Cold)	Cable color: Gray

CN203 plug (LCD module side): BHSR-02VS-1 (J.S.T Mfg. Co., Ltd.)

Adaptable socket: SM02B-BHSS-1-TB (J.S.T Mfg. Co., Ltd.)

Pin No.	Symbol	Signal	Remarks
1	VBLH	High voltage (Hot)	Cable color: Red
2	VBLC	Low voltage (Cold)	Cable color: Gray

CN204 plug (LCD module side): BHSR-02VS-1 (J.S.T Mfg. Co., Ltd.)

Adaptable socket: SM02B-BHSS-1-TB (J.S.T Mfg. Co., Ltd.)

Pin No.	Symbol	Signal	Remarks
1	VBLH	High voltage (Hot)	Cable color: Pink
2	VBLC	Low voltage (Cold)	Cable color: Gray

CN205 plug (LCD module side): BHSR-02VS-1 (J.S.T Mfg. Co., Ltd.)

Adaptable socket: SM02B-BHSS-1-TB (J.S.T Mfg. Co., Ltd.)

Pin No.	Symbol	Signal	Remarks
1	VBLH	High voltage (Hot)	Cable color: White
2	VBLC	Low voltage (Cold)	Cable color: Gray

CN206 plug (LCD module side): BHSR-02VS-1 (J.S.T Mfg. Co., Ltd.)

Adaptable socket: SM02B-BHSS-1-TB (J.S.T Mfg. Co., Ltd.)

Pin No.	Symbol	Signal	Remarks
1	VBLH	High voltage (Hot)	Cable color: Red
2	VBLC	Low voltage (Cold)	Cable color: Gray

**NEC** NEC LCD Technologies, Ltd.**NL128102BC29-01B/01C**

(2) NL128102BC29-01C

CN201 plug (LCD module side): BHSR-02VS-1 (J.S.T Mfg. Co., Ltd.)

Adaptable socket: SM02B-BHSS-1-TB (J.S.T Mfg. Co., Ltd.)

Pin No.	Symbol	Signal	Remarks
1	VBLH	High voltage (Hot)	Cable color: Pink
2	VBLC	Low voltage (Cold)	Cable color: White

CN202 plug (LCD module side): BHSR-02VS-1 (J.S.T Mfg. Co., Ltd.)

Adaptable socket: SM02B-BHSS-1-TB (J.S.T Mfg. Co., Ltd.)

Pin No.	Symbol	Signal	Remarks
1	VBLH	High voltage (Hot)	Cable color: White
2	VBLC	Low voltage (Cold)	Cable color: White

CN203 plug (LCD module side): BHSR-02VS-1 (J.S.T Mfg. Co., Ltd.)

Adaptable socket: SM02B-BHSS-1-TB (J.S.T Mfg. Co., Ltd.)

Pin No.	Symbol	Signal	Remarks
1	VBLH	High voltage (Hot)	Cable color: Red
2	VBLC	Low voltage (Cold)	Cable color: White

CN204 plug (LCD module side): BHSR-02VS-1 (J.S.T Mfg. Co., Ltd.)

Adaptable socket: SM02B-BHSS-1-TB (J.S.T Mfg. Co., Ltd.)

Pin No.	Symbol	Signal	Remarks
1	VBLH	High voltage (Hot)	Cable color: Pink
2	VBLC	Low voltage (Cold)	Cable color: White

CN205 plug (LCD module side): BHSR-02VS-1 (J.S.T Mfg. Co., Ltd.)

Adaptable socket: SM02B-BHSS-1-TB (J.S.T Mfg. Co., Ltd.)

Pin No.	Symbol	Signal	Remarks
1	VBLH	High voltage (Hot)	Cable color: White
2	VBLC	Low voltage (Cold)	Cable color: White

CN206 plug (LCD module side): BHSR-02VS-1 (J.S.T Mfg. Co., Ltd.)

Adaptable socket: SM02B-BHSS-1-TB (J.S.T Mfg. Co., Ltd.)

Pin No.	Symbol	Signal	Remarks
1	VBLH	High voltage (Hot)	Cable color: Red
2	VBLC	Low voltage (Cold)	Cable color: White

## 4.5.3 Positions of plugs and socket

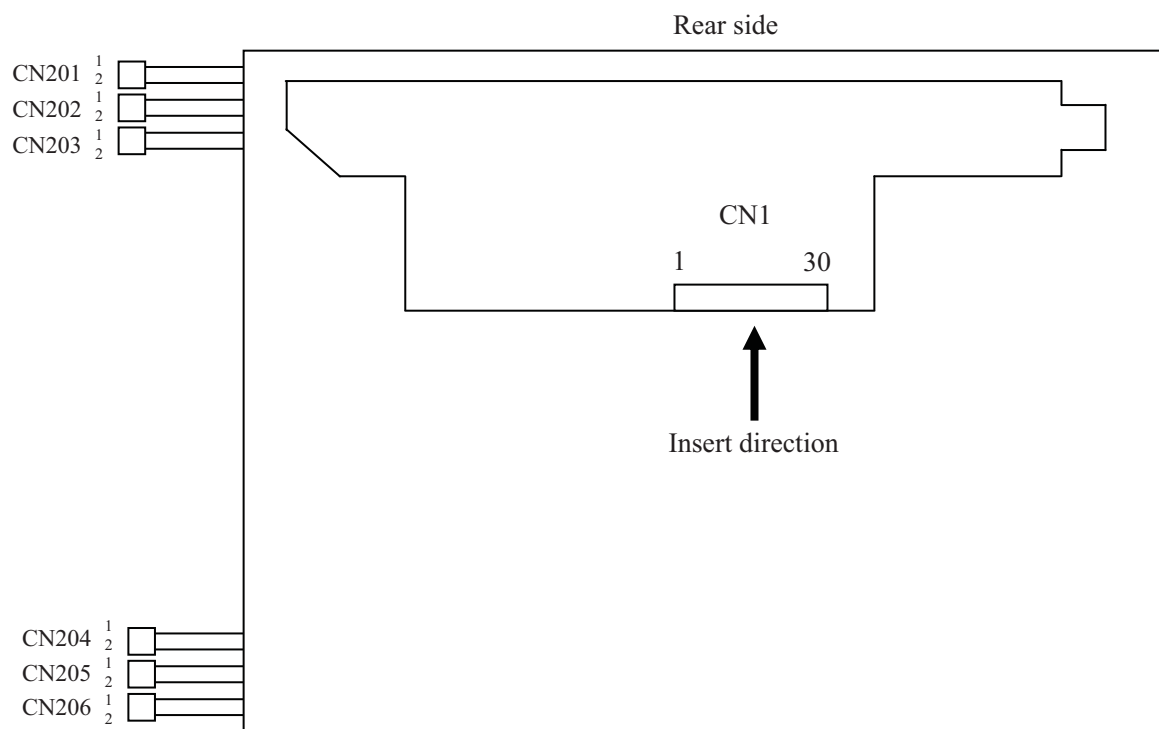

4.6 SELECTION OF LVDS DATA INPUT MAP

4.6.1 Mode A

Input data		Note1	Transmitter		CN1		
			Pin	DS90CF383, C385 or equivalent	Pin Symbol		
Odd pixel data and control signal	RA0	→	51	TXIN0			
	RA1	→	52	TXIN1	TA1-	→ 1 DA0-	
	RA2	→	54	TXIN2	TA1+	→ 2 DA0+	
	RA3	→	55	TXIN3			
	RA4	→	56	TXIN4	TB1-	→ 3 DA1-	
	RA5	→	3	TXIN6	TB1+	→ 4 DA1+	
	GA0	→	4	TXIN7			
	GA1	→	6	TXIN8	TC1-	→ 5 DA2-	
	GA2	→	7	TXIN9	TC1+	→ 6 DA2+	
	GA3	→	11	TXIN12		→ 7 GND	
	GA4	→	12	TXIN13	TCLK1-	→ 8 CKA-	
	GA5	→	14	TXIN14	TCLK1+	→ 9 CKA+	
	BA0	→	15	TXIN15			
	BA1	→	19	TXIN18	TD1-	→ 10 DA3-	
	BA2	→	20	TXIN19	TD1+	→ 11 DA3+	
	BA3	→	22	TXIN20			
	BA4	→	23	TXIN21			
	BA5	→	24	TXIN22			
	Note3	RSVD	→	27	TXIN24		
	Note3	RSVD	→	28	TXIN25		
		DE	→	30	TXIN26		
		RA6	→	50	TXIN27		
		RA7	→	2	TXIN5		
		GA6	→	8	TXIN10		
		GA7	→	10	TXIN11		
		BA6	→	16	TXIN16		
		BA7	→	18	TXIN17		
	Note3	RSVD	→	25	TXIN23		
		CLK	→	31	CLKIN		
	Even pixel data	RB0	→	51	TXIN0		
		RB1	→	52	TXIN1	TA2-	→ 12 DB0-
RB2		→	54	TXIN2	TA2+	→ 13 DB0+	
RB3		→	55	TXIN3		→ 14 GND	
RB4		→	56	TXIN4	TB2-	→ 15 DB1-	
RB5		→	3	TXIN6	TB2+	→ 16 DB1+	
GB0		→	4	TXIN7		→ 17 GND	
GB1		→	6	TXIN8	TC2-	→ 18 DB2-	
GB2		→	7	TXIN9	TC2+	→ 19 DB2+	
GB3		→	11	TXIN12			
GB4		→	12	TXIN13	TCLK2-	→ 20 CKB-	
GB5		→	14	TXIN14	TCLK2+	→ 21 CKB+	
BB0		→	15	TXIN15			
BB1		→	19	TXIN18	TD2-	→ 22 DB3-	
BB2		→	20	TXIN19	TD2+	→ 23 DB3+	
BB3		→	22	TXIN20		→ 24 GND	
BB4		→	23	TXIN21		→ 25 TxSEL	
BB5		→	24	TXIN22		→ 26 RSVD	
Note3		RSVD	→	27	TXIN24		→ 27 N.C.
Note3		RSVD	→	28	TXIN25		→ 28 VDD
Note3		RSVD	→	30	TXIN26		→ 29 VDD
		RB6	→	50	TXIN27		→ 30 VDD
		RB7	→	2	TXIN5		
		GB6	→	8	TXIN10		
		GB7	→	10	TXIN11		
		BB6	→	16	TXIN16		
		BB7	→	18	TXIN18		
Note3		RSVD	→	25	TXIN23		
		CLK	→	31	CLKIN		



NEC LCD Technologies, Ltd.

NL128102BC29-01B/01C

4.6.2 Mode B

Input data		Note1		Transmitter				Note2		CN1		
				Pin	THC63LVDF83A/R or equivalent	Pin	THC63LVD823 or equivalent			Pin	Symbol	
Odd pixel data and control signal	RA2	→	51	TA0	53	R12		→	1	DA0-		
	RA3	→	52	TA1	54	R13	TA1-	→	2	DA0+		
	RA4	→	54	TA2	57	R14	TA1+	→				
	RA5	→	55	TA3	58	R15						
	RA6	→	56	TA4	59	R16	TB1-	→	3	DA1-		
	RA7	→	3	TA5	60	R17	TB1+	→	4	DA1+		
	GA2	→	4	TA6	63	G12						
	GA3	→	6	TB0	64	G13	TC1-	→	5	DA2-		
	GA4	→	7	TB1	65	G14	TC1+	→	6	DA2+		
	GA5	→	11	TB2	66	G15				7	GND	
	GA6	→	12	TB3	67	G16	TCLK1-	→	8	CKA-		
	GA7	→	14	TB4	68	G17	TCLK1+	→	9	CKA+		
	BA2	→	15	TB5	73	B12						
	BA3	→	19	TB6	74	B13						
	BA4	→	20	TC0	75	B14	TD1-	→	10	DA3-		
	BA5	→	22	TC1	76	B15	TD1+	→	11	DA3+		
	BA6	→	23	TC2	77	B16						
	BA7	→	24	TC3	78	B17						
	Note3	RSVD	→	27	TC4	7	RSVD					
	Note3	RSVD	→	28	TC5	8	RSVD					
		DE	→	30	TC6	9	DE					
		RA0	→	50	TD0	51	R10					
		RA1	→	2	TD1	52	R11					
		GA0	→	8	TD2	61	G10					
		GA1	→	10	TD3	62	G11					
		BA0	→	16	TD4	69	B10					
	Note3	BA1	→	18	TD5	70	B11					
	Note3	RSVD	→	25	TD6	-						
		CLK	→	31	CLKIN	10	CLK					
	Even pixel data	RB2	→	51	TA0	81	R22					
		RB3	→	52	TA1	82	R23	TA2-	→	12	DB0-	
RB4		→	54	TA2	83	R24	TA2+	→	13	DB0+		
RB5		→	55	TA3	84	R25				14	GND	
RB6		→	56	TA4	85	R26	TB2-	→	15	DB1-		
RB7		→	3	TA5	86	R27	TB2+	→	16	DB1+		
GB2		→	4	TA6	91	G22						
GB3		→	6	TB0	92	G23	TC2-	→	17	GND		
GB4		→	7	TB1	93	G24	TC2+	→	18	DB2-		
GB5		→	11	TB2	94	G25						
GB6		→	12	TB3	95	G26	TCLK2-	→	19	DB2+		
GB7		→	14	TB4	96	G27	TCLK2+	→	20	CKB-		
BB2		→	15	TB5	99	B22						
BB3		→	19	TB6	100	B23						
BB4		→	20	TC0	1	B24	TD2-	→	21	CKB+		
BB5		→	22	TC1	2	B25	TD2+	→	22	DB3-		
BB6		→	23	TC2	5	B26						
BB7		→	24	TC3	6	B27						
Note3		RSVD	→	27	TC4	-					23	DB3+
Note3		RSVD	→	28	TC5	-					24	GND
Note3		RSVD	→	30	TC6	-					25	TxSEL
		RB0	→	50	TD0	79	R20				26	RSVD
		RB1	→	2	TD1	80	R21				27	N.C.
		GB0	→	8	TD2	89	G20				28	VDD
		GB1	→	10	TD3	90	G21				29	VDD
		BB0	→	16	TD4	97	B20				30	VDD
		BB1	→	18	TD5	98	B21					
Note3		RSVD	→	25	TD6	-						
		CLK	→	31	CLKIN	-						

Note1: LSB (Least Significant Bit) – RA0, GA0, BA0, RB0, GB0, BB0

MSB (Most Significant Bit) – RA7, GA7, BA7, RB7, GB7, BB7

Note2: Twist pair wires with 100Ω (Characteristic impedance) should be connected between LCD panel signal processing board and LVDS transmitter.

Note3: Input signal RSVD is not used inside the product, but do not keep pin open to avoid noise problem.

4.7 DISPLAY COLORS AND INPUT DATA SIGNALS

This product can display in equivalent to 16,777,216 colors in 256 gray scales. Also the relation between display colors and input data signals is as the following table.

Display colors		Data signal (0: Low level, 1: High level)																							
		RA7	RA6	RA5	RA4	RA3	RA2	RA1	RA0	GA7	GA6	GA5	GA4	GA3	GA2	GA1	GA0	BA7	BA6	BA5	BA4	BA3	BA2	BA1	BA0
		RB7	RB6	RB5	RB4	RB3	RB2	RB1	RB0	GB7	GB6	GB5	GB4	GB3	GB2	GB1	GB0	BB7	BB6	BB5	BB4	BB3	BB2	BB1	BB0
Basic Colors	Black	0	0	0	0	0	0	0	0	0	0	0	0	0	0	0	0	0	0	0	0	0	0	0	0
	Blue	0	0	0	0	0	0	0	0	0	0	0	0	0	0	0	0	1	1	1	1	1	1	1	1
	Red	1	1	1	1	1	1	1	1	0	0	0	0	0	0	0	0	0	0	0	0	0	0	0	0
	Magenta	1	1	1	1	1	1	1	1	0	0	0	0	0	0	0	0	1	1	1	1	1	1	1	1
	Green	0	0	0	0	0	0	0	0	1	1	1	1	1	1	1	1	0	0	0	0	0	0	0	0
	Cyan	0	0	0	0	0	0	0	0	1	1	1	1	1	1	1	1	1	1	1	1	1	1	1	1
	Yellow	1	1	1	1	1	1	1	1	1	1	1	1	1	1	1	1	0	0	0	0	0	0	0	0
	White	1	1	1	1	1	1	1	1	1	1	1	1	1	1	1	1	1	1	1	1	1	1	1	1
Red gray scale	Black	0	0	0	0	0	0	0	0	0	0	0	0	0	0	0	0	0	0	0	0	0	0	0	0
		0	0	0	0	0	0	0	1	0	0	0	0	0	0	0	0	0	0	0	0	0	0	0	0
	dark	0	0	0	0	0	0	1	0	0	0	0	0	0	0	0	0	0	0	0	0	0	0	0	0
	↑																								
	↓																								
bright	1	1	1	1	1	1	0	1	0	0	0	0	0	0	0	0	0	0	0	0	0	0	0	0	
Red	1	1	1	1	1	1	1	0	0	0	0	0	0	0	0	0	0	0	0	0	0	0	0	0	
Red	1	1	1	1	1	1	1	1	0	0	0	0	0	0	0	0	0	0	0	0	0	0	0	0	
Green gray scale	Black	0	0	0	0	0	0	0	0	0	0	0	0	0	0	0	0	0	0	0	0	0	0	0	0
		0	0	0	0	0	0	0	0	0	0	0	0	0	0	0	1	0	0	0	0	0	0	0	0
	dark	0	0	0	0	0	0	0	0	0	0	0	0	0	0	1	0	0	0	0	0	0	0	0	0
	↑																								
	↓																								
bright	0	0	0	0	0	0	0	0	1	1	1	1	1	1	0	1	0	0	0	0	0	0	0	0	
Green	0	0	0	0	0	0	0	0	1	1	1	1	1	1	1	1	0	0	0	0	0	0	0	0	
Green	0	0	0	0	0	0	0	0	1	1	1	1	1	1	1	1	0	0	0	0	0	0	0	0	
Blue gray scale	Black	0	0	0	0	0	0	0	0	0	0	0	0	0	0	0	0	0	0	0	0	0	0	0	0
		0	0	0	0	0	0	0	0	0	0	0	0	0	0	0	0	0	0	0	0	0	0	0	1
	dark	0	0	0	0	0	0	0	0	0	0	0	0	0	0	0	0	0	0	0	0	0	0	1	0
	↑																								
	↓																								
bright	0	0	0	0	0	0	0	0	0	0	0	0	0	0	0	0	1	1	1	1	1	1	0	1	
Blue	0	0	0	0	0	0	0	0	0	0	0	0	0	0	0	0	1	1	1	1	1	1	1	0	
Blue	0	0	0	0	0	0	0	0	0	0	0	0	0	0	0	0	1	1	1	1	1	1	1	1	

## 4.8 DISPLAY POSITION

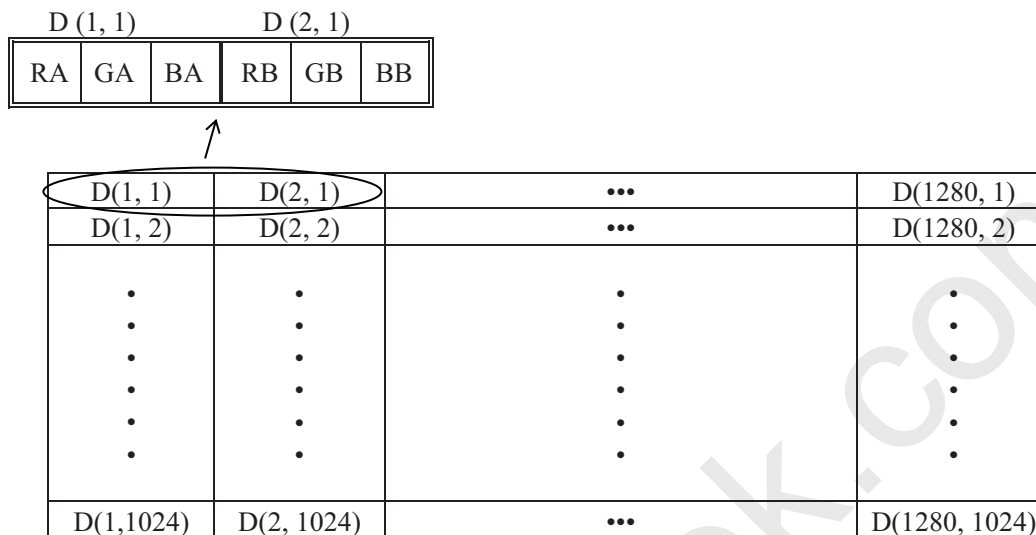

## 4.9 INPUT SIGNAL TIMINGS

## 4.9.1 Timing characteristics

Parameter		Symbol	min.	typ.	max.	Unit	Remarks	
CLK	Frequency	1/tc	49	54	59	MHz	18.52 ns (typ.)	
	Duty	-				-	Note2	
	Rise time, Fall time	-				ns		
DATA	CLK-DATA	Setup time				ns	Note2	
		Hold time				ns		
	Rise time, Fall time	-				ns		
DE	Horizontal	Cycle	th	12.3	15.63	20.59	μs	64.0 kHz (typ.) Note1, Note2, Note3
		Display period	thd	660	844	1,024	CLK	
				640			CLK	
	Vertical (One frame)	Cycle	tv	13.1	16.6	17.5	ms	60.0 Hz (typ.) Note1
		Display period	tvd	1,030	1,066	1,422	H	
				1,024			H	
CLK-DE	Setup time	-				ns	Note2	
	Hold time	-				ns		
	Rise time, Fall time	-				ns		

Note1: Definition of parameters is as follows.

tc = 1CLK, th = 1H

Note2: See the data sheet of LVDS transmitter.

Note3: "th" must keep the fluctuation within  $\pm 1$  CLK, because of avoidance of image sticking.

## 4.9.2 Input signal timing chart

## Horizontal timing

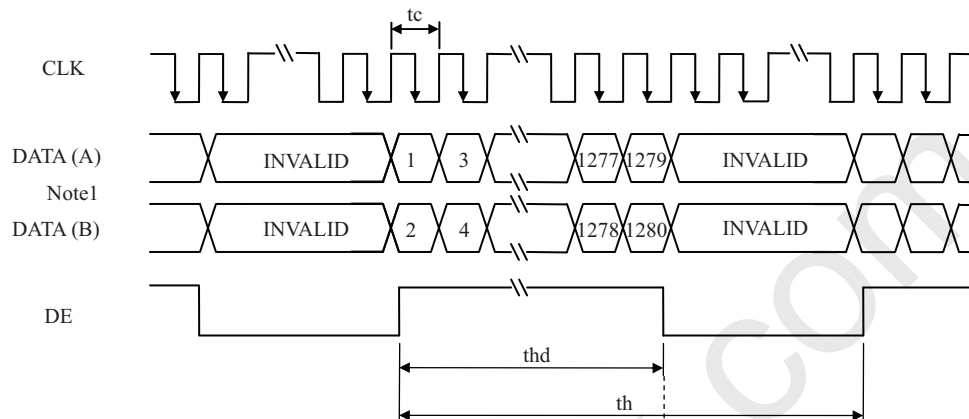

## Vertical timing

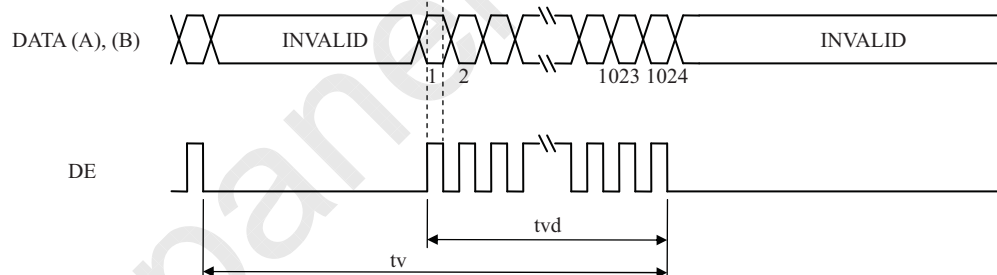

Note1: DATA (A) = RA0-RA7, GA0-GA7, BA0-BA7  
DATA (B) = RB0-RB7, GB0-GB7, BB0-BB7

**NEC** NEC LCD Technologies, Ltd.

**NL128102BC29-01B/01C**

#### 4.10 OPTICS

##### 4.10.1 Optical characteristics

###### (1) NL128102BC29-01B

(Note1, Note2)

Parameter	Condition	Symbol	min.	typ.	max.	Unit	Measuring instrument	Remarks	
Luminance	White at center $\theta R = 0^\circ, \theta L = 0^\circ, \theta U = 0^\circ, \theta D = 0^\circ$	L	220	280	-	cd/m <sup>2</sup>	BM5A or SR-3	-	
Contrast ratio	White/Black at center $\theta R = 0^\circ, \theta L = 0^\circ, \theta U = 0^\circ, \theta D = 0^\circ$	CR	300	450	-	-	BM5A or SR-3	Note3	
Luminance uniformity	White $\theta R = 0^\circ, \theta L = 0^\circ, \theta U = 0^\circ, \theta D = 0^\circ$	LU	-	1.1	1.25	-	BM-5A	Note4	
Chromaticity	White	x coordinate	Wx	0.283	0.313	0.343	-	SR-3	Note5
		y coordinate	Wy	0.299	0.329	0.359	-		
	Red	x coordinate	Rx	0.62	0.65	0.68	-		
		y coordinate	Ry	0.30	0.33	0.36	-		
	Green	x coordinate	Gx	0.26	0.29	0.32	-		
		y coordinate	Gy	0.59	0.62	0.65	-		
Blue	x coordinate	Bx	0.11	0.14	0.17	-			
	y coordinate	By	0.05	0.08	0.11	-			
Color gamut	$\theta R = 0^\circ, \theta L = 0^\circ, \theta U = 0^\circ, \theta D = 0^\circ$ at center, against NTSC color space	C	65	72	-	%			
Response time	Black to white	Ton	-	10	20	ms	BM-5A	Note6	
	White to black	Toff	-	10	20	ms		Note7	
Viewing angle	Right	$\theta U = 0^\circ, \theta D = 0^\circ, CR \geq 10$	$\theta R$	70	85	-	BM-5A	Note8	
	Left	$\theta U = 0^\circ, \theta D = 0^\circ, CR \geq 10$	$\theta L$	70	85	-			
	Up	$\theta R = 0^\circ, \theta L = 0^\circ, CR \geq 10$	$\theta U$	70	85	-			
	Down	$\theta R = 0^\circ, \theta L = 0^\circ, CR \geq 10$	$\theta D$	70	85	-			

###### (2) NL128102BC29-01C

(Note1, Note2)

Parameter	Condition	Symbol	min.	typ.	max.	Unit	Measuring instrument	Remarks	
Luminance	White at center $\theta R = 0^\circ, \theta L = 0^\circ, \theta U = 0^\circ, \theta D = 0^\circ$	L	220	270	-	cd/m <sup>2</sup>	BM5A or SR-3	-	
Contrast ratio	White/Black at center $\theta R = 0^\circ, \theta L = 0^\circ, \theta U = 0^\circ, \theta D = 0^\circ$	CR	300	450	-	-	BM5A or SR-3	Note3	
Luminance uniformity	White $\theta R = 0^\circ, \theta L = 0^\circ, \theta U = 0^\circ, \theta D = 0^\circ$	LU	-	1.1	1.25	-	BM-5A	Note4	
Chromaticity	White	x coordinate	Wx	0.270	0.300	0.330	-	SR-3	Note5
		y coordinate	Wy	0.285	0.315	0.345	-		
	Red	x coordinate	Rx	0.62	0.65	0.68	-		
		y coordinate	Ry	0.30	0.33	0.36	-		
	Green	x coordinate	Gx	0.26	0.29	0.32	-		
		y coordinate	Gy	0.59	0.62	0.65	-		
Blue	x coordinate	Bx	0.11	0.14	0.17	-			
	y coordinate	By	0.05	0.08	0.11	-			
Color gamut	$\theta R = 0^\circ, \theta L = 0^\circ, \theta U = 0^\circ, \theta D = 0^\circ$ at center, against NTSC color space	C	65	72	-	%			
Response time	Black to white	Ton	-	10	20	ms	BM-5A	Note6	
	White to black	Toff	-	10	20	ms		Note7	
Viewing angle	Right	$\theta U = 0^\circ, \theta D = 0^\circ, CR \geq 10$	$\theta R$	70	85	-	BM-5A	Note8	
	Left	$\theta U = 0^\circ, \theta D = 0^\circ, CR \geq 10$	$\theta L$	70	85	-			
	Up	$\theta R = 0^\circ, \theta L = 0^\circ, CR \geq 10$	$\theta U$	70	85	-			
	Down	$\theta R = 0^\circ, \theta L = 0^\circ, CR \geq 10$	$\theta D$	70	85	-			

Note1: These are initial characteristics.

Note2: Measurement conditions are as follows.

$T_a = 25^\circ\text{C}$ ,  $V_{DD} = 5.0\text{V}$ ,  $I_{BL} = 6.0\text{mA}$  rms/lamp, Display mode: SXGA, Horizontal cycle = 64.0kHz, Vertical cycle = 60.0Hz

Optical characteristics are measured after 20 minutes from working the product, in the dark room. Also measurement method for luminance is as follows.

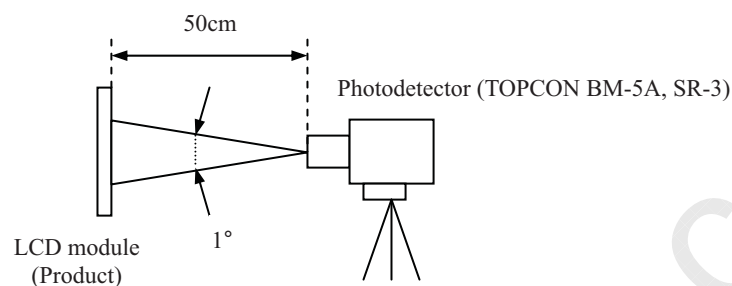

Note3: See "4.10.2 Definition of contrast ratio".

Note4: See "4.10.3 Definition of luminance uniformity".

Note5: These coordinates are found on CIE 1931 chromaticity diagram.

Note6: Product surface temperature: TopF = 35°C

Note7: See "4.10.4 Definition of response times".

Note8: See "4.10.5 Definition of viewing angles".

## 4.10.2 Definition of contrast ratio

The contrast ratio is calculated by using the following formula.

$$\text{Contrast ratio (CR)} = \frac{\text{Luminance of white screen}}{\text{Luminance of black screen}}$$

## 4.10.3 Definition of luminance uniformity

The luminance uniformity is calculated by using following formula.

$$\text{Luminance uniformity (LU)} = \frac{\text{Maximum luminance from ① to ⑤}}{\text{Minimum luminance from ① to ⑤}}$$

The luminance is measured at near the 5 points shown below.

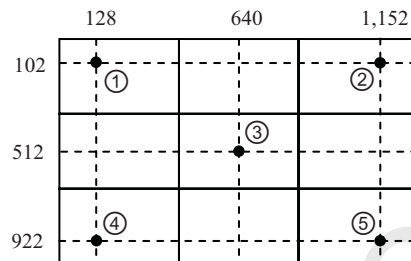

## 4.10.4 Definition of response times

Response time is measured, the luminance changes from "black" to "white", or "white" to "black" on the same screen point, by photo-detector. Ton is the time it takes the luminance change from 10% up to 90%. Also Toff is the time it takes the luminance change from 90% down to 10% (See the following diagram.).

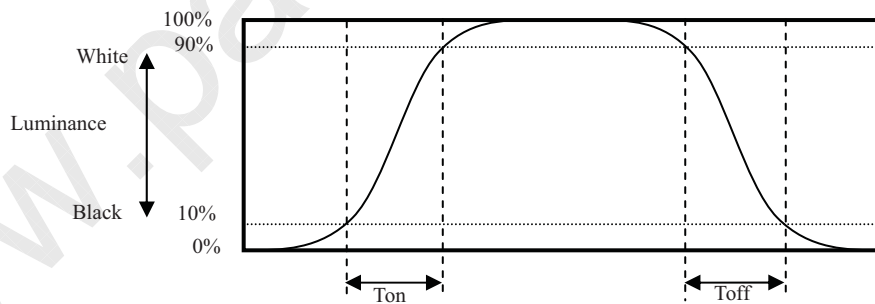

## 4.10.5 Definition of viewing angles

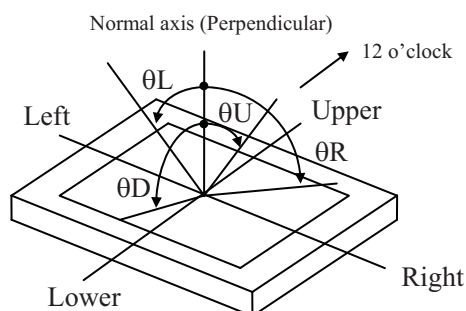

## 5. RELIABILITY TESTS

Test item		Condition	Judgment	Note1
High temperature and humidity (Operation)		① $60 \pm 2^{\circ}\text{C}$ , RH = 60%, 240hours ② Display data is white.	No display malfunctions	
Heat cycle (Operation)		① $0 \pm 3^{\circ}\text{C}$ ...1hour $55 \pm 3^{\circ}\text{C}$ ...1hour ② 50cycles, 4hours/cycle ③ Display data is white.		
Thermal shock (Non operation)		① $-20 \pm 3^{\circ}\text{C}$ ...30minutes $60 \pm 3^{\circ}\text{C}$ ...30minutes ② 100cycles, 1hour/cycle ③ Temperature transition time is within 5 minutes.		
Vibration (Non operation)		① 5 to 100Hz, $11.76\text{m/s}^2$ ② 1 minute/cycle ③ X, Y, Z direction ④ 10 times each directions	No display malfunctions No physical damages	
Mechanical shock (Non operation)		① $294\text{m/s}^2$ , 11ms ② X, Y, Z direction ③ 3 times each directions		
ESD (Operation)		① 150pF, 150 $\Omega$ , $\pm 10\text{kV}$ ② 9 places on a panel surface Note2 ③ 10 times each places at 1 sec interval	No display malfunctions	
Dust (Operation)		① Sample dust: No.15 (by JIS-Z8901) ② 15 seconds stir ③ 8 times repeat at 1 hour interval		
Low pressure	Operation	① 53.3 kPa ② $0^{\circ}\text{C} \pm 3^{\circ}\text{C}$ ...24 hours ③ $55^{\circ}\text{C} \pm 3^{\circ}\text{C}$ ...24 hours		
	Non-operation	① 15 kPa ② $-20^{\circ}\text{C} \pm 3^{\circ}\text{C}$ ...24 hours ③ $60^{\circ}\text{C} \pm 3^{\circ}\text{C}$ ...24 hours		

Note1: Display functions are checked under the same conditions as product inspection.

Note2: See the following figure for discharge points

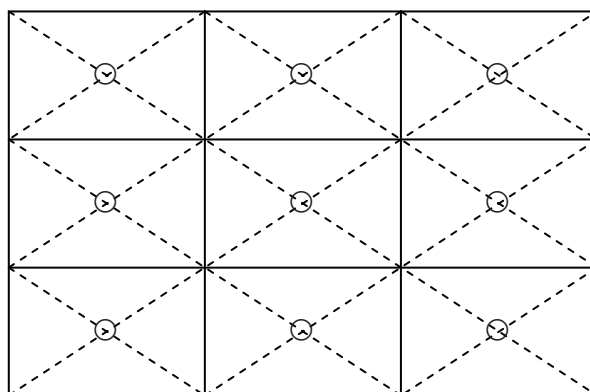



## 6. PRECAUTIONS

### 6.1 MEANING OF CAUTION SIGNS

The following caution signs have very important meaning. **Be sure to read "6.2 CAUTIONS" and "6.3 ATTENTIONS", after understanding these contents!**



This sign has the meaning that customer will be injured by himself or the product will sustain a damage, if customer has wrong operations.



This sign has the meaning that customer will get an electrical shock, if customer has wrong operations.



This sign has the meaning that customer will be injured by himself, if customer has wrong operations.

### 6.2 CAUTIONS



**\* Do not touch the working backlight. Customer will be in danger of an electric shock.**



**\* Do not touch the working backlight. Customer will be in danger of burn injury.  
\* Do not shock and press the LCD panel and the backlight! There is a danger of breaking, because they are made of glass. (Shock: To be not greater 294m/s<sup>2</sup> and to be not greater 11ms, Pressure: To be not greater 19.6 N)**

### 6.3 ATTENTIONS



#### 6.3.1 Handling of the product

- ① Take hold of both ends without touch the circuit board cover when customer pulls out products (LCD modules) from inner packing box. If customer touches it, products may be broken down or out of adjustment, because of stress to mounting parts.
- ② Do not hook cables nor pull connection cables such as lamp cable and so on, for fear of damage.
- ③ If customer puts down the product temporarily, the product puts on flat subsoil as a display side turns down.
- ④ Take the measures of electrostatic discharge such as earth band, ionic shower and so on, when customer handles the product, because products may be damaged by electrostatic.
- ⑤ The torque for mounting screws must never exceed 0.67N·m. Higher torque values might result in distortion of the bezel. And the screw length must be 4.0mm to 7.0mm.
- ⑥ The product must be installed using mounting holes without undue stress such as bends or twist (See outline drawings). And do not add undue stress to any portion (such as bezel flat area) except mounting hole portion.  
Bends or twist described above and undue stress to any portion except mounting hole portion may cause display un-uniformity.
- ⑦ Do not press or rub on the sensitive display surface. If customer clean on the panel surface, NEC recommends using the cloth with ethanolic liquid such as screen cleaner for LCD.
- ⑧ Do not push-pull the interface connectors while the product is working, because wrong power sequence may break down the product.

- ⑨ When installing the lamp cable, do not attach the lamp cable on the metal part of the LCD module directly. This may cause leakage high frequency current to the metal part, then the brightness may decrease or the lamp may not light.
- ⑩ When installing the lamp cable, do not locate the lamp cable on the signal processing board. A noise may occur on the display image.
- ⑪ When customer handles the product, use of an original protection sheet on the product surface (polarizer) is recommended for protection of product surface. Adhesive type protection sheet may change color or properties of the polarizer.

### 6.3.2 Environment

- ① Do not operate or store in high temperature, high humidity, dewdrop atmosphere or corrosive gases. Keep the product in antistatic pouch in room temperature, because of avoidance for dusts and sunlight, if customer stores the product.
- ② In order to prevent dew condensation occurring by temperature difference, the product packing box must be opened after leave under the environment of an unpacking room temperature enough. Because a situation of dew condensation occurring is changed by the environmental temperature and humidity, evaluate the leaving time sufficiently. (Recommendation leaving time: 6 hour or more with packing state)
- ③ Do not operate in high magnetic field. Circuit boards may be broken down by it.
- ④ This product is not designed as radiation hardened.

### 6.3.3 Characteristics

**The following items are neither defects nor failures.**

- ① Response time, luminance and color may be changed by ambient temperature.
- ② The LCD may be seemed luminance non-uniformity, flicker, vertical seam or small spot by display patterns.
- ③ Optical characteristics (e.g. luminance, display uniformity, etc.) gradually is going to change depending on operating time, and especially low temperature, because the LCD has cold cathode fluorescent lamps.
- ④ Do not display the fixed pattern for a long time because it may cause image sticking. Use a screen saver, if the fixed pattern is displayed on the screen.
- ⑤ The display color may be changed by viewing angle because of the use of condenser sheet in the backlight.
- ⑥ Optical characteristics may be changed by input signal timings.
- ⑦ The interference noise of input signal frequency for this product's signal processing board and luminance control frequency of customer's backlight inverter may appear on a display. Set up luminance control frequency of backlight inverter so that the interference noise does not appear.

### 6.3.4 Other

- ① All GND and VDD terminals should be used without any non-connected lines.
- ② Do not disassemble a product or adjust variable resistors without permission of NEC.
- ③ Pay attention not to insert waste materials inside of products, if customer uses screwdrivers.
- ④ Pack the product with original shipping package, because of avoidance of some damages during transportation, when customer returns it to NEC for repair and so on.
- ⑤ The LCD module by itself or integrated into end product should be packed and transported with display in the vertically position. Otherwise the display characteristics may be impaired.

7. OUTLINE DRAWINGS  
7.1 FRONT VIEW

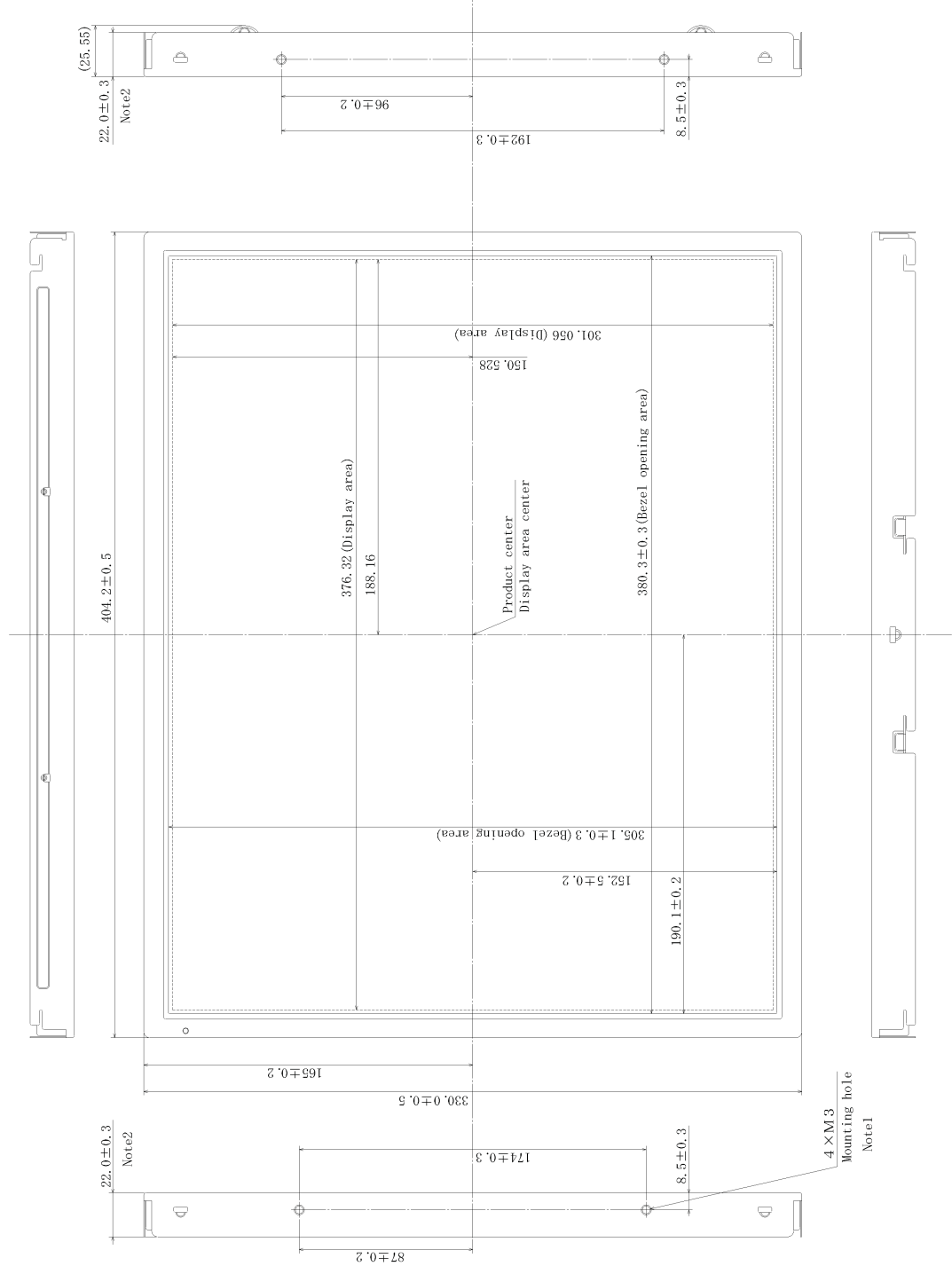

Note1: The torque for mounting screws must never exceed 0.67N-m. And the screw length must be 4.0mm to 7.0mm.  
Note2: Excluding lamp cable, cable clamp and projections.

Unit: mm

7.2 REAR VIEW

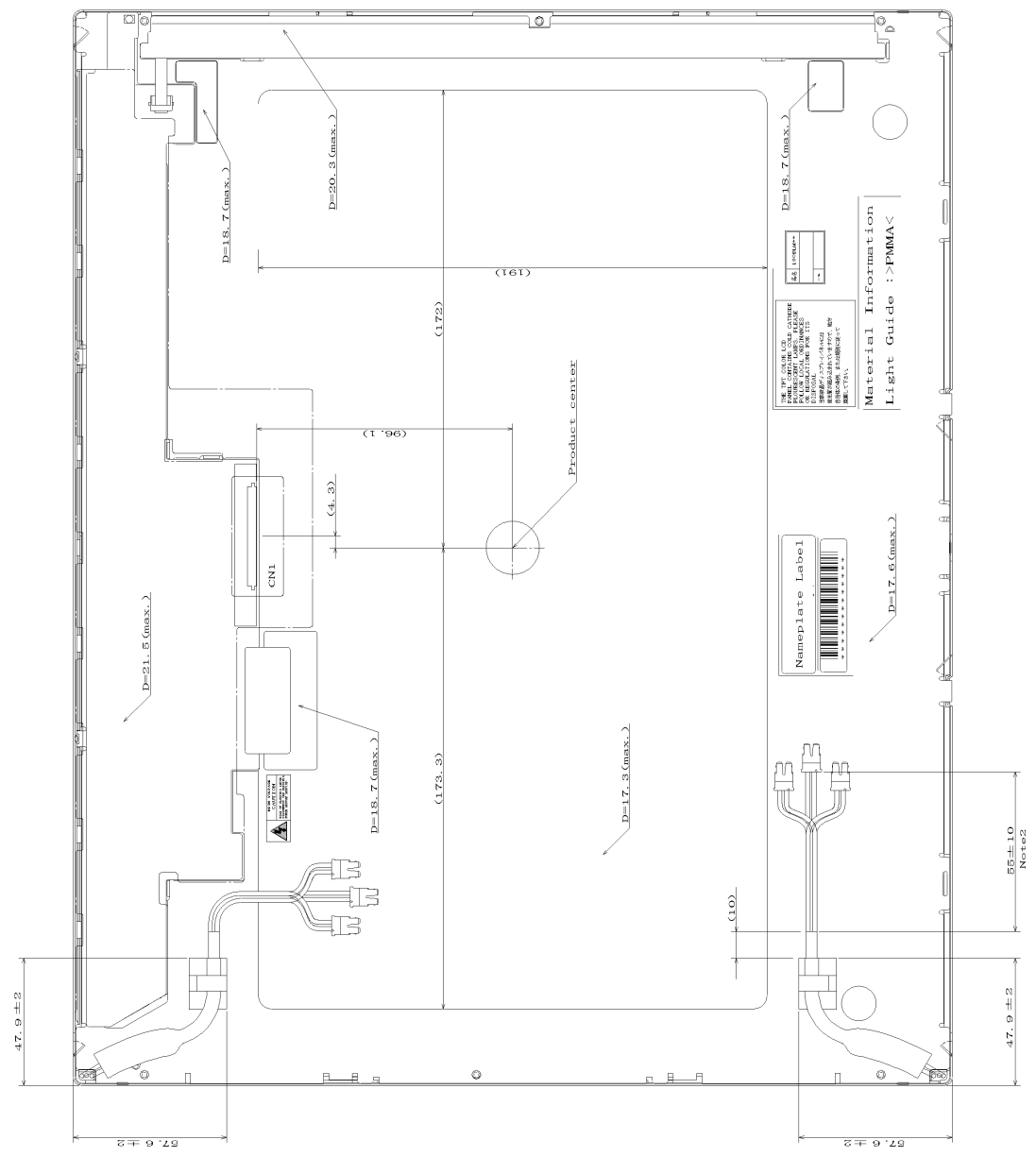

Note1: The values in parentheses are for reference.  
 Note2: The cable of up side and down side is the same length.

Unit: mm