

NEC NEC LCD Technologies, Ltd.

TFT COLOR LCD MODULE

NL160120BC27-14

54cm (21.3 Type)

UXGA

LVDS Interface (2 ports)

DATA SHEET 

DOD-PD-1335 (1st edition)

**All information is subject to change without notice.
Please confirm the sales representative before
starting to design your system.**

INTRODUCTION

The Copyright to this document belongs to NEC LCD Technologies, Ltd. (hereinafter called "NEC"). No part of this document will be used, reproduced or copied without prior written consent of NEC.

NEC does and will not assume any liability for infringement of patents, copyrights or other intellectual property rights of any third party arising out of or in connection with application of the products described herein except for that directly attributable to mechanisms and workmanship thereof. No license, express or implied, is granted under any patent, copyright or other intellectual property right of NEC.

Some electronic parts/components would fail or malfunction at a certain rate. In spite of every effort to enhance reliability of products by NEC, the possibility of failures and malfunction might not be avoided entirely. To prevent the risks of damage to death, human bodily injury or other property arising out thereof or in connection therewith, each customer is required to take sufficient measures in its safety designs and plans including, but not limited to, redundant system, fire-containment and anti-failure.

The products are classified into three quality grades: "**Standard**", "**Special**", and "**Specific**" of the highest grade of a quality assurance program at the choice of a customer. Each quality grade is designed for applications described below. Any customer who intends to use a product for application other than that of Standard quality grade is required to contact an NEC sales representative in advance.

The **Standard** quality grade applies to the products developed, designed and manufactured in accordance with the NEC standard quality assurance program, which are designed for such application as any failure or malfunction of the products (sets) or parts/components incorporated therein a customer uses are, directly or indirectly, free of any damage to death, human bodily injury or other property, like general electronic devices.

Examples: Computers, office automation equipment, communications equipment, test and measurement equipment, audio and visual equipment, home electronic appliances, machine tools, personal electronic equipment, industrial robots, etc.

The **Special** quality grade applies to the products developed, designed and manufactured in accordance with an NEC quality assurance program stricter than the standard one, which are designed for such application as any failure or malfunction of the products (sets) or parts/components incorporated therein a customer uses might directly cause any damage to death, human bodily injury or other property, or such application under more severe condition than that defined in the Standard quality grade without such direct damage.

Examples: Control systems for transportation equipment (automobiles, trains, ships, etc.), traffic control systems, anti-disaster systems, anti-crime systems, medical equipment not specifically designed for life support, safety equipment, etc.

The **Specific** quality grade applies to the products developed, designed and manufactured in accordance with the standards or quality assurance program designated by a customer who requires an extremely higher level of reliability and quality for such products.

Examples: Military systems, aircraft control equipment, aerospace equipment, nuclear reactor control systems, medical equipment/devices/systems for life support, etc.

The quality grade of this product is the "**Standard**" unless otherwise specified in this document.

CONTENTS

INTRODUCTION 2

1. OUTLINE..... 4

 1.1 STRUCTURE AND PRINCIPLE..... 4

 1.2 APPLICATION..... 4

 1.3 FEATURES..... 4

2. GENERAL SPECIFICATIONS 5

3. BLOCK DIAGRAM..... 6

4. DETAILED SPECIFICATIONS 7

 4.1 MECHANICAL SPECIFICATIONS..... 7

 4.2 ABSOLUTE MAXIMUM RATINGS 7

 4.3 ELECTRICAL CHARACTERISTICS..... 8

 4.3.1 LCD panel signal processing board 8

 4.3.2 Backlight lamp..... 9

 4.3.3 Power supply voltage ripple..... 10

 4.3.4 Fuse..... 10

 4.4 POWER SUPPLY VOLTAGE SEQUENCE 11

 4.5 CONNECTIONS AND FUNCTIONS FOR INTERFACE PINS..... 12

 4.5.1 LCD panel signal processing board 12

 4.5.2 Backlight lamp..... 14

 4.5.3 Positions of plug and socket 15

 4.6 LVDS DATA INPUT MAP 16

 4.6.1 Mode A 16

 4.6.2 Mode B 17

 4.6.3 Mode C 18

 4.7 DISPLAY COLORS AND INPUT DATA SIGNALS 19

 4.8 INPUT SIGNAL TIMINGS 20

 4.8.1 Timing characteristics 20

 4.8.2 Input signal timing chart 20

 4.9 DISPLAY POSITIONS..... 21

 4.10 TEN-bit LOOK UP TABLE FOR GAMMA ADJUSTMENT 22

 4.11 LUT SERIAL COMMUCATION TIMINGS 25

 4.11.1 Timing Chart 25

 4.11.2 Timing specifications 26

 4.12 OPTICS..... 27

 4.12.1 Optical characteristics 27

 4.12.2 Definition of contrast ratio 28

 4.12.3 Definition of luminance uniformity 28

 4.12.4 Definition of response times 28

 4.12.5 Definition of viewing angles..... 28

5. RELIABILITY TESTS..... 29

6. PRECAUTIONS 30

 6.1 MEANING OF CAUTION SIGNS 30

 6.2 CAUTIONS 30

 6.3 ATTENTIONS 30

 6.3.1 Handling of the product 30

 6.3.2 Environment..... 31

 6.3.3 Characteristics..... 32

 6.3.4 Other 32

7. OUTLINE DRAWINGS 33

 7.1 FRONT VIEW 33

 7.2 REAR VIEW 34

1. OUTLINE

1.1 STRUCTURE AND PRINCIPLE

Color LCD module NL160120BC27-14 module is composed of the amorphous silicon thin film transistor liquid crystal display (a-Si TFT LCD) panel structure with driver LSIs for driving the TFT (Thin Film Transistor) array and a backlight.

The a-Si TFT LCD panel structure is injected liquid crystal material into a narrow gap between the TFT array glass substrate and a color-filter glass substrate.

Color (Red, Green, Blue) data signals from a host system (e.g. signal generator, etc.) are modulated into best form for active matrix system by a signal processing board, and sent to the driver LSIs which drive the individual TFT arrays.

The TFT array as an electro-optical switch regulates the amount of transmitted light from the backlight assembly, when it is controlled by data signals. Color images are created by regulating the amount of transmitted light through the TFT array of red, green and blue dots.

1.2 APPLICATION

- Monitor for PC

1.3 FEATURES

- Ultra-wide viewing angle (Adoption of Super-Advanced Super Fine TFT (SA-SFT))
- Wide color gamut
- High resolution
- LVDS interface
- Adjustable gamma characteristics by using built-in 10-bit LUT (look up table)
- Selectable LVDS data input map
- Small foot print
- Incorporated edge light type backlight (without inverter)
- Acquisition product for UL60950-1/CSA C22.2 No.60950-1-03 (File number: E170632)

2. GENERAL SPECIFICATIONS

Display area	432.0 (H) × 324.0 (V) mm
Diagonal size of display	54cm (21.3 inches)
Drive system	a-Si TFT active matrix
Display color	16,777,216 colors
Pixel	1,600 (H) × 1,200 (V) pixels
Pixel arrangement	RGB (Red dot, Green dot, Blue dot) vertical stripe
Dot pitch	0.090 (H) × 0.270 (V) mm
Pixel pitch	0.270 (H) × 0.270 (V) mm
Module size	457.0 (W) × 350.0 (H) × 25.0 (D) mm (typ.)
Weight	3,750g (typ.)
Contrast ratio	550:1 (typ.)
Viewing angle	At the contrast ratio ≥ 10:1 <ul style="list-style-type: none"> • Horizontal: Right side 85° (typ.), Left side 85° (typ.) • Vertical: Up side 85° (typ.), Down side 85° (typ.)
Designed viewing direction	Viewing angle with optimum grayscale ($\gamma=2.2$): Normal axis (Perpendicular)
Polarizer surface	Antiglare
Polarizer pencil-hardness	2H (min.) [by JIS K5400]
Color gamut	At LCD panel center 72% (typ.) [against NTSC color space]
Response time	$T_{on} + T_{off}$ (10% ← → 90%) 20ms (typ.)
Luminance	At $IBL = 6.0mArms / lamp$ 250cd/m ² (typ.)
Signal system	2 ports LVDS interface (THC63LV824 THine Electronics, Inc. or equivalent) [RGB 8-bit signals, Data enable signal (DE), Dot clock (CLK)]
Power supply voltage	LCD panel signal processing board: 12.0V
Backlight	Edge light type: 6 cold cathode fluorescent lamps (without inverter)
Power consumption	At $IBL = 6.0mArms / lamp$, Checkered flag pattern 30.7W (typ., Power dissipation of the inverter is not included.)

3. BLOCK DIAGRAM

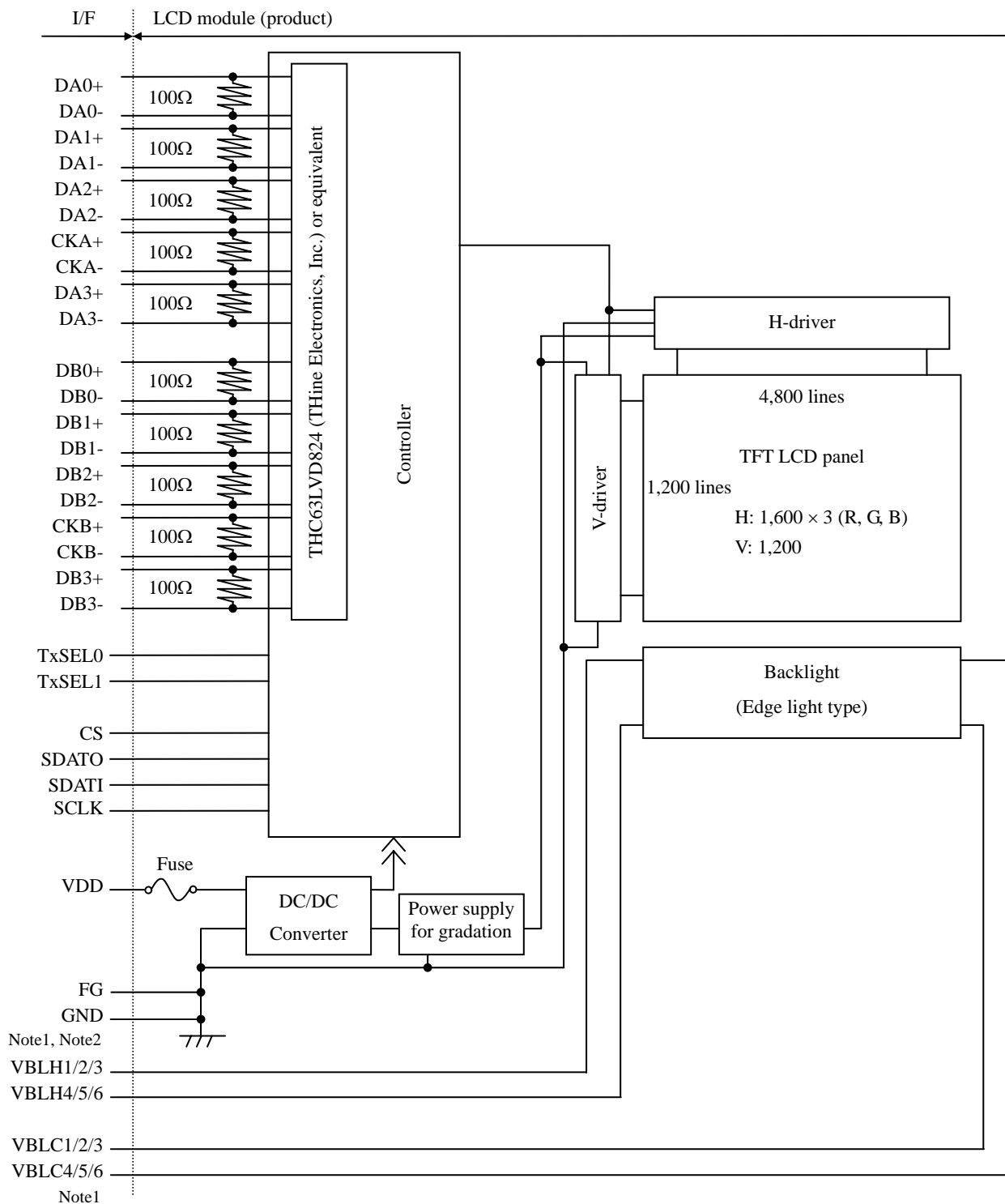

Note1: Connections between GND (Signal ground), FG (Frame ground) and VBLC (Lamp low voltage terminal) in the LCD module

GND - FG	Connected
GND - VBLC	Not connected
FG - VBLC	Not connected

Note2: GND and FG must be connected to customer equipment's ground, and it is recommended that GND, FG and customer inverter ground are connected together in customer equipment.

4. DETAILED SPECIFICATIONS

4.1 MECHANICAL SPECIFICATIONS

Parameter	Specification	Unit
Module size	457.0 +0.4/-0.3 (W) × 350.0 +0.4/-0.3 (H) × 25.0 ± 0.3 (D) Note1, Note2	mm
Display area	432.0 (H) × 324.0 (V) Note1	mm
Weight	3,750 (typ.), 4,000 (max.)	g

Note1: Excluding warpage of the signal processing board cover and the connection board cover

Note2: See "7. OUTLINE DRAWINGS".

4.2 ABSOLUTE MAXIMUM RATINGS

Parameter		Symbol	Rating	Unit	Remarks
Power supply voltage	LCD panel signal processing board	VDD	-0.3 to +14.0	V	-
	Lamp voltage	VBLH	3,000	Vrms	
Input signal voltage Note1		Vi	-0.3 to +2.8	V	VDD= 12.0V
Storage temperature		Tst	-20 to +60	°C	-
Operating temperature	Front surface	TopF	0 to +55	°C	Note2
	Rear surface	TopR	0 to +65	°C	Note3
Relative humidity Note4	RH	≤ 95	%	Ta ≤ 40°C	
		≤ 85	%	40°C < Ta ≤ 50°C	
		≤ 70	%	50°C < Ta ≤ 55°C	
Absolute humidity Note4		AH	≤ 73 Note5	g/m ³	Ta > 55°C
Operating altitude		-	≤ 4,850	m	0°C ≤ Ta ≤ 55°C
Storage altitude		-	≤ 13,600	m	-20°C ≤ Ta ≤ 60°C

Note1: DA0+/-, DA1+/-, DA2+/-, DA3+/-, CKA+/-, DB0+/-, DB1+/-, DB2+/-, DB3+/-, CKB+/-
CS, SDAT1, SCLK, TxSEL0, TxSEL1

Note2: Measured at center of LCD panel surface (including self-heat)

Note3: Measured at center of LCD module's rear shield surface (including self-heat)

Note4: No condensation

Note5: Water amount at Ta= 55°C and RH= 70%

4.3 ELECTRICAL CHARACTERISTICS

4.3.1 LCD panel signal processing board

(Ta= 25°C)

Parameter		Symbol	min.	typ.	max.	Unit	Remarks
Supply voltage		VDD	10.8	12.0	13.2	V	-
Supply current		IDD	-	310 Note1	700 Note2	mA	at VDD= 12.0V
Ripple voltage		VRP	-	-	100	mVp-p	for VDD
Differential input Threshold voltage	High	VTH	-	-	+100	mV	at VCM= 1.2V Note3, Note4
	Low	VTL	-100	-	-	mV	
Input voltage swing		VI	0	-	2.4	V	Note4
Terminating resistance		RT	-	100	-	Ω	-
Control signal input threshold voltage	High	VIH	Keep this pin open.			-	Note5
	Low	VIL	0	-	0.5	V	
Control signal input current	Low	IIL	-10	-	10	μA	
Serial communication signal input threshold voltage	High	V+	-	1.4	1.9	V	Note6
	Low	V-	0.4	0.7	-	V	
	Hysteresis	VH	0.3	-	-	V	
Output signal threshold voltage	High	VOH	1.9	-	-	V	Note7
	Low	VOL	-	-	0.4	V	
Output signal current	High	IOH	-4	-	-	mA	
	Low	IOL	-	-	4	mA	

Note1: Checkered flag pattern (by EIAJ ED-2522)

Note2: Pattern for maximum current

Note3: Common mode voltage for LVDS driver

Note4: DA0+/-, DA1+/-, DA2+/-, DA3+/-, CKA+/-, DB0+/-, DB1+/-, DB2+/-, DB3+/-, CKB+/-

Note5: TxSEL0, TxSEL1

Note6: CS, SDATI, SCLK

Note7: SDATO

4.3.2 Backlight lamp

(Ta= 25°C, Note1)

Parameter	Symbol	min.	typ.	max.	Unit	Remarks
Lamp current	IBL	3.0	6.0	7.0	mArms	at IBL= 6.0mArms: L= 250cd/m ² (typ.) Note3
Lamp voltage	VBLH	-	750	-	Vrms	Note2, Note3
Lamp starting voltage	VS	1,220	-	-	Vrms	Ta= 25°C Note2, Note3, Note4
		1,460	-	-	Vrms	Ta= 0°C Note2, Note3, Note4
Lamp oscillation frequency	FO	50	56	60	kHz	Note5

Note1: This product consists of 6 backlight lamps, and these specifications are for each lamp.

Note2: The lamp voltage cycle between lamps should be kept on a same phase. "VS" and "VBLH" are the voltage value between low voltage side (Cold) and high voltage side (Hot).

Note3: The asymmetric ratio of working waveform for lamps (Lamp voltage peak ratio, Lamp current peak ratio and waveform space ratio) should be less than 5 % (See the following figure.). If the waveform is asymmetric, DC (Direct current) element apply into the lamp. In this case, a lamp lifetime may be shortened, because a distribution of a lamp enclosure substance inclines toward one side between low voltage terminal (Cold terminal) and high voltage terminal (Hot terminal). When designing the inverter, evaluate asymmetric of lamp working waveform sufficiently.

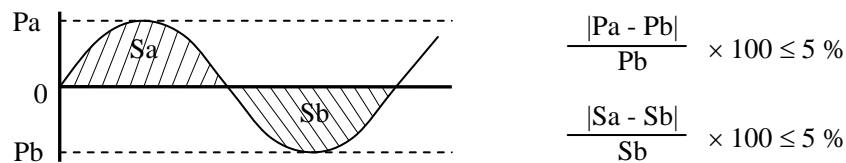

Pa: Supply voltage/current peak for positive, Pb: Supply voltage/current peak for negative
 Sa: Waveform space for positive part, Sb: Waveform space for negative part

Note4: The inverter should be designed so that the lamp starting voltage can be maintained for more than 1 second. Otherwise the lamp may not be turned on.

Note5: In case "FO" is not the recommended value, beat noise may display on the screen, because of interference between "FO" and "1/th". Recommended value of "FO" is as following.

$$FO = \frac{1}{4} \times \frac{1}{th} \times (2n-1)$$

th: Horizontal cycle period (See "4.8.1 Timing characteristics".)

n: Natural number (1, 2, 3)

Note6: Method of lamp cable installation may invite fluctuation of lamp current and voltage or asymmetric of lamp working waveform. When designing method of lamp cable installation, evaluate the fluctuation of lamp current, voltage and working waveform sufficiently.

4.3.3 Power supply voltage ripple

This product works, even if the ripple voltage levels are beyond the permissible values as following the table, but there might be noise on the display image.

Power supply voltage		Ripple voltage (Measure at input terminal of power supply)	Note1	Unit
VDD	12.0V	≤ 100		mVp-p

Note1: The permissible ripple voltage includes spike noise.

4.3.4 Fuse

Parameter	Fuse		Rating	Fusing current	Remarks
	Type	Supplier			
VDD	FCC16132AB	KAMAYA ELECTRIC Co., Ltd.	1.25A	2.5A, 5 seconds maximum	Note1
			32V		

Note1: The power supply capacity should be more than the fusing current. If it is less than the fusing current, the fuse may not blow in a short time, and then nasty smell, smoke and so on may occur.

4.5 CONNECTIONS AND FUNCTIONS FOR INTERFACE PINS

4.5.1 LCD panel signal processing board

(1) CN1

Socket (LCD module side): DF19G-30P-1H (56) (Hirose Electric Co., Ltd. (HRS))

Adaptable plug: DF19-30S-1C (Hirose Electric Co., Ltd. (HRS))

Pin No.	Symbol	Signal	Remarks			
1	DA0-	Pixel data A0	Odd pixel data Input (LVDS differential signal) Note1			
2	DA0+					
3	DA1-	Pixel data A1	Odd pixel data Input (LVDS differential signal) Note1			
4	DA1+					
5	DA2-	Pixel data A2	Odd pixel data Input (LVDS differential signal) Note1			
6	DA2+					
7	GND	Ground	Signal ground Note2			
8	CKA-	Pixel clock	Odd pixel clock Input (LVDS differential signal) Note1			
9	CKA+					
10	DA3-	Pixel data A3	Odd pixel data Input (LVDS differential signal) Note1			
11	DA3+					
12	DB0-	Pixel data B0	Even pixel data Input (LVDS differential signal) Note1			
13	DB0+					
14	GND	Ground	Signal ground Note2			
15	DB1-	Pixel data B1	Even pixel data Input (LVDS differential signal) Note1			
16	DB1+					
17	GND	Ground	Signal ground Note2			
18	DB2-	Pixel data B2	Even pixel data Input (LVDS differential signal) Note1			
19	DB2+					
20	CKB-	Pixel clock	Even pixel clock Input (LVDS differential signal) Note1			
21	CKB+					
22	DB3-	Pixel data B3	Even pixel data Input (LVDS differential signal) Note1			
23	DB3+					
24	GND	Ground	Signal ground Note2			
25	TxSEL0	Selection of LVDS data input map	Note3, Note4	TxSEL1	TxSEL0	Mode
26	TxSEL1			Open	Open	A
				Open	Low	B
				Low	Open	C
		Low	Low	A		
27	GND	Ground	Signal ground Note2			
28	VDD	Power supply	12V Note2			
29	VDD					
30	VDD					

Note1: Twist pair wires with 100Ω (Characteristic impedance) should be used between LCD panel signal processing board and LVDS transmitter.

Note2: All GND and VDD terminals should be used without any non-connected lines.

Note3: This terminal is pulled-up in the product. (Pull-up resistance: 50kΩ)

Note4: See "4.6 LVDS DATA INPUT MAP".

(2) CN3

Socket (LCD module side): SM10B-SRSS-TB(LF)(SN) (J.S.T. Mfg Co., Ltd.)

Adaptable plug: SHR-10V-S, SHR-10V-S-B or 10SR-3S (J.S.T. Mfg Co., Ltd.)

Pin No.	Symbol	Signal	Remarks
1	RSVD	Reserved	Keep these pins open.
2	RSVD		
3	RSVD		
4	GND	Ground	Signal ground Note1
5	CS	Chip selection	For LUT communication control Note2
6	SDATO	Serial data output	For LUT output signal
7	SDATI	Serial data input	For LUT communication control Note3
8	SCLK	Serial clock	For LUT communication control Note3
9	GND	Ground	Signal ground Note1
10	RSVD	Reserved	Keep this pin open.

Note1: All GND terminals should be used without any non-connected lines.

Note2: This terminal is pulled-up in the product. (Pull-up resistance: 50kΩ)

Note3: These terminals are pulled-down in the product. (Pull-down resistance: 50kΩ)

4.5.2 Backlight lamp

Attention: VBLH and VBLC must be connected correctly. Wrong connections will cause electric shock and also break down of the product.

CN201 plug (LCD module side): BHSR-02VS-1 (J.S.T. Mfg Co., Ltd.)
 Adaptable socket: SM02B-BHSS-1-TB(LF)(SN)
 SM02B-BHSS-1-TB (J.S.T. Mfg Co., Ltd.)

Pin No.	Symbol	Function	Remarks
1	VBLH1	Upper side lamp, High voltage (Hot)	Cable color: Pink
2	VBLC1	Upper side lamp, Low voltage (Cold)	Cable color: Gray

CN202 plug (LCD module side): BHSR-02VS-1 (J.S.T. Mfg Co., Ltd.)
 Adaptable socket: SM02B-BHSS-1-TB(LF)(SN)
 SM02B-BHSS-1-TB (J.S.T. Mfg Co., Ltd.)

Pin No.	Symbol	Function	Remarks
1	VBLH2	Upper side lamp, High voltage (Hot)	Cable color: White
2	VBLC2	Upper side lamp, Low voltage (Cold)	Cable color: Gray

CN203 plug (LCD module side): BHSR-02VS-1 (J.S.T. Mfg Co., Ltd.)
 Adaptable socket: SM02B-BHSS-1-TB(LF)(SN)
 SM02B-BHSS-1-TB (J.S.T. Mfg Co., Ltd.)

Pin No.	Symbol	Function	Remarks
1	VBLH3	Upper side lamp, High voltage (Hot)	Cable color: Red
2	VBLC3	Upper side lamp, Low voltage (Cold)	Cable color: Gray

CN204 plug (LCD module side): BHSR-02VS-1 (J.S.T. Mfg Co., Ltd.)
 Adaptable socket: SM02B-BHSS-1-TB(LF)(SN)
 SM02B-BHSS-1-TB (J.S.T. Mfg Co., Ltd.)

Pin No.	Symbol	Function	Remarks
1	VBLH4	Lower side lamp, High voltage (Hot)	Cable color: Pink
2	VBLC4	Lower side lamp, Low voltage (Cold)	Cable color: Gray

CN205 plug (LCD module side): BHSR-02VS-1 (J.S.T. Mfg Co., Ltd.)
 Adaptable socket: SM02B-BHSS-1-TB(LF)(SN)
 SM02B-BHSS-1-TB (J.S.T. Mfg Co., Ltd.)

Pin No.	Symbol	Function	Remarks
1	VBLH5	Lower side lamp, High voltage (Hot)	Cable color: White
2	VBLC5	Lower side lamp, Low voltage (Cold)	Cable color: Gray

CN206 plug (LCD module side): BHSR-02VS-1 (J.S.T. Mfg Co., Ltd.)
 Adaptable socket: SM02B-BHSS-1-TB(LF)(SN)
 SM02B-BHSS-1-TB (J.S.T. Mfg Co., Ltd.)

Pin No.	Symbol	Function	Remarks
1	VBLH6	Lower side lamp, High voltage (Hot)	Cable color: Red
2	VBLC6	Lower side lamp, Low voltage (Cold)	Cable color: Gray

4.5.3 Positions of plug and socket

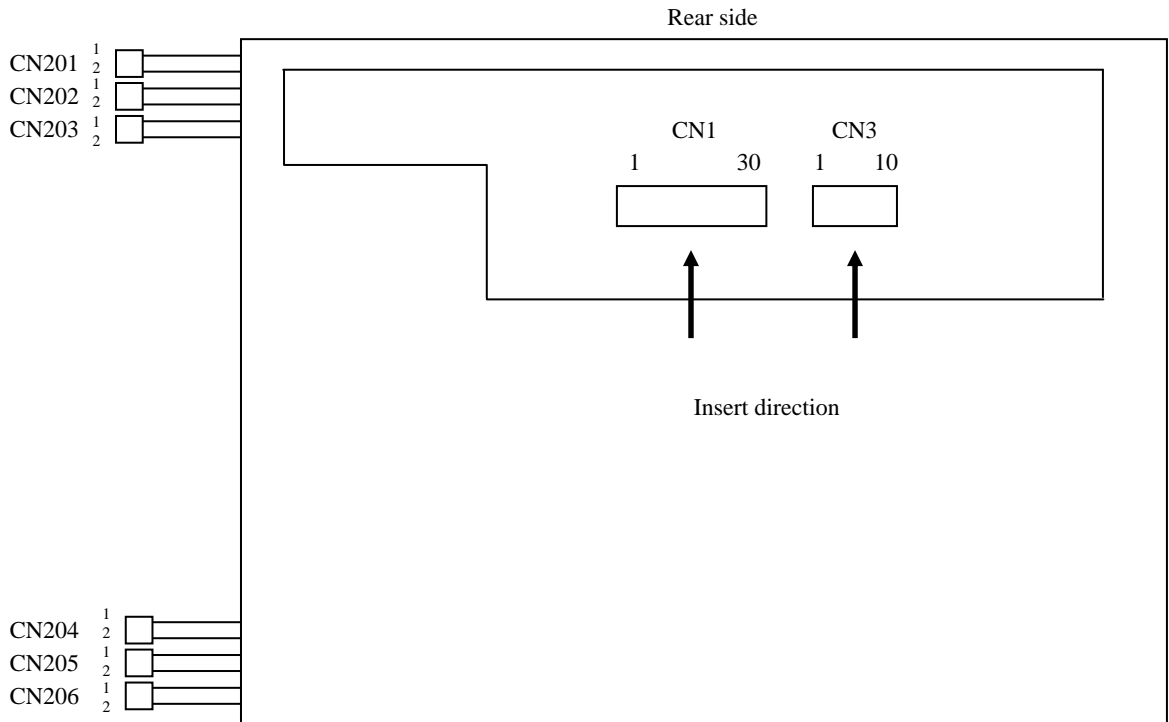

4.6 LVDS DATA INPUT MAP

4.6.1 Mode A

Input data		Note1	Transmitter				CN1			
			Pin	THC63LVDF83A	Pin	THC63LVD823				
Odd pixel data and control signal	RA2	→	51	TA0	53	R12	Note2 TA1- → TA1+ → TB1- → TB1+ → TC1- → TC1+ → TCLK1- → TCLK1+ → TD1- → TD1+ →	Pin	Symbol	
	RA3	→	52	TA1	54	R13		1	DA0-	
	RA4	→	54	TA2	57	R14		2	DA0+	
	RA5	→	55	TA3	58	R15				
	RA6	→	56	TA4	59	R16		3	DA1-	
	RA7	→	3	TA5	60	R17		4	DA1+	
	GA2	→	4	TA6	63	G12				
	GA3	→	6	TB0	64	G13		5	DA2-	
	GA4	→	7	TB1	65	G14		6	DA2+	
	GA5	→	11	TB2	66	G15		7	GND	
	GA6	→	12	TB3	67	G16		8	CKA-	
	GA7	→	14	TB4	68	G17	9	CKA+		
	BA2	→	15	TB5	73	B12				
	BA3	→	19	TB6	74	B13				
	BA4	→	20	TC0	75	B14				
	BA5	→	22	TC1	76	B15				
	BA6	→	23	TC2	77	B16				
	BA7	→	24	TC3	78	B17				
	Note3	RSVD	→	27	TC4	7	RSVD			
	Note3	RSVD	→	28	TC5	8	RSVD			
		DE	→	30	TC6	9	DE			
		RA0	→	50	TD0	51	R10			
		RA1	→	2	TD1	52	R11			
		GA0	→	8	TD2	61	G10			
		GA1	→	10	TD3	62	G11			
		BA0	→	16	TD4	69	B10			
		BA1	→	18	TD5	70	B11			
	Note3	RSVD	→	25	TD6	-	-			
		CLK	→	31	CLKIN	10	CLK			
	Even pixel data	RB2	→	51	TA0	81	R22	Note2 TA2- → TA2+ → TB2- → TB2+ → TC2- → TC2+ → TCLK2- → TCLK2+ → TD2- → TD2+ →	Pin	Symbol
		RB3	→	52	TA1	82	R23		12	DB0-
RB4		→	54	TA2	83	R24	13		DB0+	
RB5		→	55	TA3	84	R25	14		GND	
RB6		→	56	TA4	85	R26	15		DB1-	
RB7		→	3	TA5	86	R27	16		DB1+	
GB2		→	4	TA6	91	G22	17		GND	
GB3		→	6	TB0	92	G23	18		DB2-	
GB4		→	7	TB1	93	G24	19		DB2+	
GB5		→	11	TB2	94	G25				
GB6		→	12	TB3	95	G26	20		CKB-	
GB7		→	14	TB4	96	G27	21	CKB+		
BB2		→	15	TB5	99	B22				
BB3		→	19	TB6	100	B23	22	DB3-		
BB4		→	20	TC0	1	B24	23	DB3+		
BB5		→	22	TC1	2	B25	24	GND		
BB6		→	23	TC2	5	B26	25	TxSEL0		
BB7		→	24	TC3	6	B27	26	TxSEL1		
Note3		RSVD	→	27	TC4	-	-	27	GND	
Note3		RSVD	→	28	TC5	-	-	28	VDD	
Note3		RSVD	→	30	TC6	-	-	29	VDD	
		RB0	→	50	TD0	79	R20	30	VDD	
		RB1	→	2	TD1	80	R21			
		GB0	→	8	TD2	89	G20			
		GB1	→	10	TD3	90	G21			
		BB0	→	16	TD4	97	B20			
		BB1	→	18	TD5	98	B21			
Note3		RSVD	→	25	TD6	-	-			
		CLK	→	31	CLKIN	-	-			

4.6.2 Mode B

Input data		Transmitter		CNI		
Note1		Pin	DS90CF383, C385	Note2		
Odd pixel data and control signal	RA7	→ 51	TXIN0			
	RA6	→ 52	TXIN1	TA1-	→ 1 DA0-	
	RA5	→ 54	TXIN2	TA1+	→ 2 DA0+	
	RA4	→ 55	TXIN3			
	RA3	→ 56	TXIN4	TB1-	→ 3 DA1-	
	RA2	→ 3	TXIN6	TB1+	→ 4 DA1+	
	GA7	→ 4	TXIN7			
	GA6	→ 6	TXIN8	TC1-	→ 5 DA2-	
	GA5	→ 7	TXIN9	TC1+	→ 6 DA2+	
	GA4	→ 11	TXIN12			
	GA3	→ 12	TXIN13	TCLK1-	→ 8 CKA-	
	GA2	→ 14	TXIN14	TCLK1+	→ 9 CKA+	
	BA7	→ 15	TXIN15			
	BA6	→ 19	TXIN18	TD1-	→ 10 DA3-	
	BA5	→ 20	TXIN19	TD1+	→ 11 DA3+	
	BA4	→ 22	TXIN20			
	BA3	→ 23	TXIN21			
	BA2	→ 24	TXIN22			
	Note3 RSVD	→ 27	TXIN24			
	Note3 RSVD	→ 28	TXIN25			
	DE	→ 30	TXIN26			
	RA1	→ 50	TXIN27			
	RA0	→ 2	TXIN5			
	GA1	→ 8	TXIN10			
	GA0	→ 10	TXIN11			
	BA1	→ 16	TXIN16			
	BA0	→ 18	TXIN17			
	Note3 RSVD	→ 25	TXIN23			
	CLK	→ 31	CLKIN			
	Even pixel data	RB7	→ 51	TXIN0		
		RB6	→ 52	TXIN1	TA2-	→ 12 DB0-
RB5		→ 54	TXIN2	TA2+	→ 13 DB0+	
RB4		→ 55	TXIN3			
RB3		→ 56	TXIN4	TB2-	→ 15 DB1-	
RB2		→ 3	TXIN6	TB2+	→ 16 DB1+	
GB7		→ 4	TXIN7			
GB6		→ 6	TXIN8	TC2-	→ 18 DB2-	
GB5		→ 7	TXIN9	TC2+	→ 19 DB2+	
GB4		→ 11	TXIN12			
GB3		→ 12	TXIN13	TCLK2-	→ 20 CKB-	
GB2		→ 14	TXIN14	TCLK2+	→ 21 CKB+	
BB7		→ 15	TXIN15			
BB6		→ 19	TXIN18	TD2-	→ 22 DB3-	
BB5		→ 20	TXIN19	TD2+	→ 23 DB3+	
BB4		→ 22	TXIN20			
BB3		→ 23	TXIN21			
BB2		→ 24	TXIN22			
Note3 RSVD		→ 27	TXIN24			
Note3 RSVD		→ 28	TXIN25			
Note3 RSVD		→ 30	TXIN26			
RB1		→ 50	TXIN27			
RB0		→ 2	TXIN5			
GB1		→ 8	TXIN10			
GB0		→ 10	TXIN11			
BB1		→ 16	TXIN16			
BB0		→ 18	TXIN17			
Note3 RSVD		→ 25	TXIN23			
CLK		→ 31	CLKIN			

4.6.3 Mode C

Input data		Note1	Transmitter		CN1			
			Pin	DS90CF383, C385		Pin Symbol		
Odd pixel data and control signal	RA0	→	51	TXIN0	Note2	1	DA0-	
	RA1	→	52	TXIN1		TA1- →	2	DA0+
	RA2	→	54	TXIN2		TA1+ →		
	RA3	→	55	TXIN3				
	RA4	→	56	TXIN4		TB1- →	3	DA1-
	RA5	→	3	TXIN6		TB1+ →	4	DA1+
	GA0	→	4	TXIN7				
	GA1	→	6	TXIN8		TC1- →	5	DA2-
	GA2	→	7	TXIN9		TC1+ →	6	DA2+
	GA3	→	11	TXIN12			7	GND
	GA4	→	12	TXIN13		TCLK1- →	8	CKA-
	GA5	→	14	TXIN14	TCLK1+ →	9	CKA+	
	BA0	→	15	TXIN15				
	BA1	→	19	TXIN18	TD1- →	10	DA3-	
	BA2	→	20	TXIN19	TD1+ →	11	DA3+	
	BA3	→	22	TXIN20				
	BA4	→	23	TXIN21				
	BA5	→	24	TXIN22				
	Note3	RSVD	→	27	TXIN24			
	Note3	RSVD	→	28	TXIN25			
		DE	→	30	TXIN26			
		RA6	→	50	TXIN27			
		RA7	→	2	TXIN5			
		GA6	→	8	TXIN10			
		GA7	→	10	TXIN11			
		BA6	→	16	TXIN16			
	Note3	BA7	→	18	TXIN17			
	Note3	RSVD	→	25	TXIN23			
		CLK	→	31	CLKIN			
	Even pixel data	RB0	→	51	TXIN0	Note2	12	DB0-
		RB1	→	52	TXIN1		TA2- →	13
RB2		→	54	TXIN2	TA2+ →		14	GND
RB3		→	55	TXIN3				
RB4		→	56	TXIN4	TB2- →		15	DB1-
RB5		→	3	TXIN6	TB2+ →		16	DB1+
GB0		→	4	TXIN7			17	GND
GB1		→	6	TXIN8	TC2- →		18	DB2-
GB2		→	7	TXIN9	TC2+ →		19	DB2+
GB3		→	11	TXIN12				
GB4		→	12	TXIN13	TCLK2- →		20	CKB-
GB5		→	14	TXIN14	TCLK2+ →	21	CKB+	
BB0		→	15	TXIN15				
BB1		→	19	TXIN18	TD2- →	22	DB3-	
BB2		→	20	TXIN19	TD2+ →	23	DB3+	
BB3		→	22	TXIN20		24	GND	
BB4		→	23	TXIN21		25	TxSELO	
BB5		→	24	TXIN22		26	TxSEL1	
Note3		RSVD	→	27	TXIN24		27	GND
Note3		RSVD	→	28	TXIN25		28	VDD
Note3		RSVD	→	30	TXIN26		29	VDD
		RB6	→	50	TXIN27		30	VDD
		RB7	→	2	TXIN5			
		GB6	→	8	TXIN10			
		GB7	→	10	TXIN11			
		BB6	→	16	TXIN16			
		BB7	→	18	TXIN17			
Note3		RSVD	→	25	TXIN23			
		CLK	→	31	CLKIN			

Note1: LSB (Least Significant Bit) – RA0, GA0, BA0, RB0, GB0, BB0
 MSB (Most Significant Bit) – RA7, GA7, BA7, RB7, GB7, BB7

Note2: Twist pair wires with 100Ω (Characteristic impedance) should be used between LCD panel signal processing board and LVDS transmitter.

Note3: Input signal RSVD is not used inside the product, but do not keep this pin open to avoid noise problem.

4.7 DISPLAY COLORS AND INPUT DATA SIGNALS

This product can display in equivalent to 16,777,216 colors in 256 gray scales. Also the relation between display colors and input data signals is as the following table.

Display colors		Data signal (0: Low level, 1: High level)																							
		RA7 RA6 RA5 RA4 RA3 RA2 RA1 RA0								GA7 GA6 GA5 GA4 GA3 GA2 GA1 GA0								BA7 BA6 BA5 BA4 BA3 BA2 BA1 BA0							
		RB7	RB6	RB5	RB4	RB3	RB2	RB1	RB0	GB7	GB6	GB5	GB4	GB3	GB2	GB1	GB0	BB7	BB6	BB5	BB4	BB3	BB2	BB1	BB0
Basic Colors	Black	0	0	0	0	0	0	0	0	0	0	0	0	0	0	0	0	0	0	0	0	0	0	0	0
	Blue	0	0	0	0	0	0	0	0	0	0	0	0	0	0	0	0	1	1	1	1	1	1	1	1
	Red	1	1	1	1	1	1	1	1	0	0	0	0	0	0	0	0	0	0	0	0	0	0	0	0
	Magenta	1	1	1	1	1	1	1	1	0	0	0	0	0	0	0	0	1	1	1	1	1	1	1	1
	Green	0	0	0	0	0	0	0	0	1	1	1	1	1	1	1	1	0	0	0	0	0	0	0	0
	Cyan	0	0	0	0	0	0	0	0	1	1	1	1	1	1	1	1	1	1	1	1	1	1	1	1
	Yellow	1	1	1	1	1	1	1	1	1	1	1	1	1	1	1	1	0	0	0	0	0	0	0	0
	White	1	1	1	1	1	1	1	1	1	1	1	1	1	1	1	1	1	1	1	1	1	1	1	1
Red gray scale	Black	0	0	0	0	0	0	0	0	0	0	0	0	0	0	0	0	0	0	0	0	0	0	0	0
		0	0	0	0	0	0	0	1	0	0	0	0	0	0	0	0	0	0	0	0	0	0	0	0
	dark	0	0	0	0	0	0	1	0	0	0	0	0	0	0	0	0	0	0	0	0	0	0	0	0
	↑					:																			
	↓					:																			
bright	1	1	1	1	1	1	0	1	0	0	0	0	0	0	0	0	0	0	0	0	0	0	0	0	
Red	1	1	1	1	1	1	1	0	0	0	0	0	0	0	0	0	0	0	0	0	0	0	0	0	
Red	1	1	1	1	1	1	1	1	0	0	0	0	0	0	0	0	0	0	0	0	0	0	0	0	
Green gray scale	Black	0	0	0	0	0	0	0	0	0	0	0	0	0	0	0	0	0	0	0	0	0	0	0	0
		0	0	0	0	0	0	0	0	0	0	0	0	0	0	0	1	0	0	0	0	0	0	0	0
	dark	0	0	0	0	0	0	0	0	0	0	0	0	0	0	1	0	0	0	0	0	0	0	0	0
	↑					:																			
	↓					:																			
bright	0	0	0	0	0	0	0	0	1	1	1	1	1	1	0	1	0	0	0	0	0	0	0	0	
Green	0	0	0	0	0	0	0	0	1	1	1	1	1	1	1	0	0	0	0	0	0	0	0	0	
Green	0	0	0	0	0	0	0	0	1	1	1	1	1	1	1	1	0	0	0	0	0	0	0	0	
Blue gray scale	Black	0	0	0	0	0	0	0	0	0	0	0	0	0	0	0	0	0	0	0	0	0	0	0	0
		0	0	0	0	0	0	0	0	0	0	0	0	0	0	0	0	0	0	0	0	0	0	0	1
	dark	0	0	0	0	0	0	0	0	0	0	0	0	0	0	0	0	0	0	0	0	0	0	1	0
	↑					:																			
	↓					:																			
bright	0	0	0	0	0	0	0	0	0	0	0	0	0	0	0	0	1	1	1	1	1	1	0	1	
Blue	0	0	0	0	0	0	0	0	0	0	0	0	0	0	0	0	1	1	1	1	1	1	1	0	
Blue	0	0	0	0	0	0	0	0	0	0	0	0	0	0	0	0	1	1	1	1	1	1	1	1	

4.8 INPUT SIGNAL TIMINGS

4.8.1 Timing characteristics

Parameter	Symbol	min.	typ.	max.	Unit	Remarks		
CLK	Frequency	1/ tc	60.0	64.5	67.0	MHz	LVDS transmitter input	
	Pulse width	tc	14.9	15.5	-	ns		
	Duty	-	See the data sheet of LVDS transmitter.			-		-
	Rise, fall	-				ns		
Horizontal	Cycle period	th	13.1	13.3	19.2	μ s	-	
			848	860	1,156	CLK		
	Display period	thd	800			CLK	-	
Vertical	Cycle period	1/tv	59	60	61	Hz	-	
		tv	1,206	1,250	-	H		
	Display period	tvd	1,200			H	-	
DE, DATA	Setup time	-	See the data sheet of LVDS transmitter.			ns	-	
	Hold time	-				ns		
	Rise, fall	-				ns		

4.8.2 Input signal timing chart

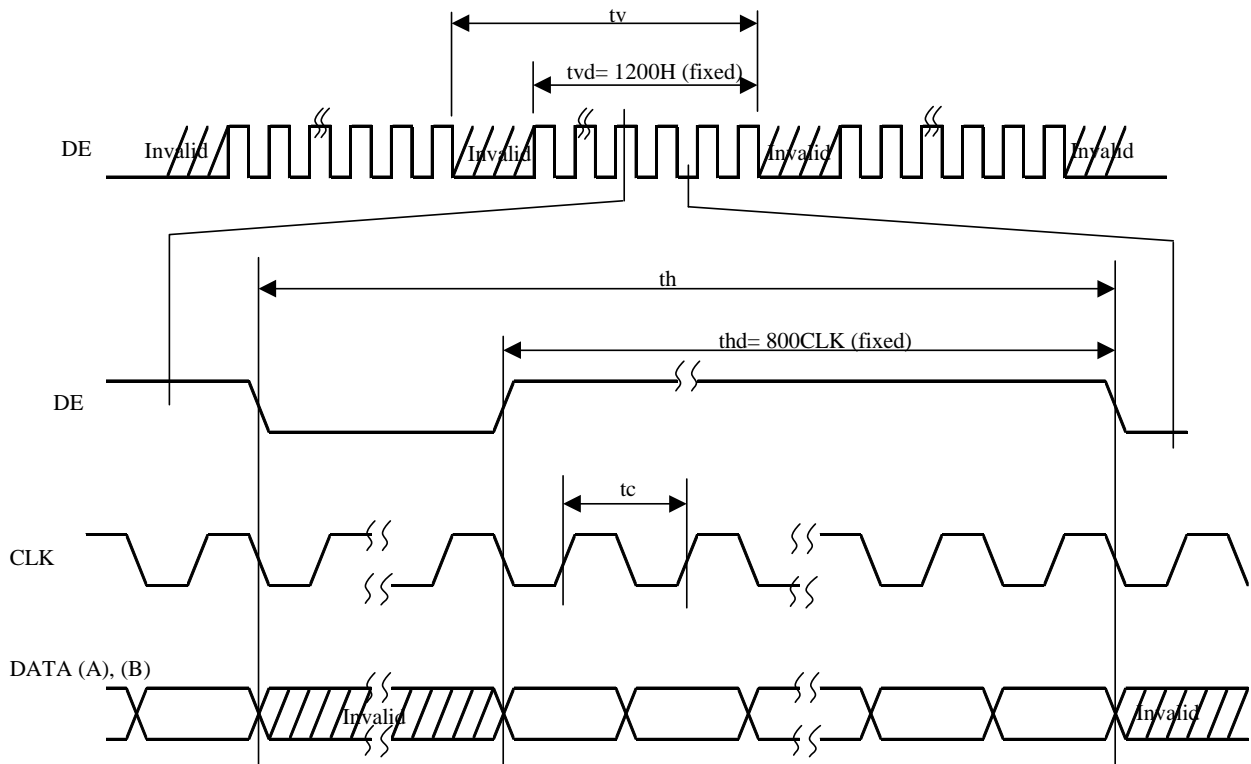

4.9 DISPLAY POSITIONS

The following table is the coordinates per pixel

Odd pixel: RA= Red data Even pixel: RB= Red data
 GA= Green data GB= Green data
 BA= Blue data BB= Blue data

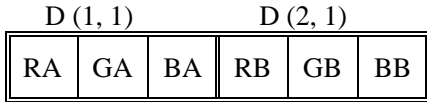

D(1, 1)	D(2, 1)	...	D(X, 1)	...	D(1599, 1)	D(1600, 1)
D(1, 2)	D(2, 2)	...	D(X, 2)	...	D(1599, 2)	D(1600, 2)
•	•	•	•	•	•	•
•	•	•••	•	•••	•	•••
•	•	•	•	•	•	•
D(1, Y)	D(2, Y)	...	D(X, Y)	...	D(1599, Y)	D(1600, Y)
•	•	•	•	•	•	•
•	•	•••	•	•••	•	•
•	•	•	•	•	•	•
D(1, 1199)	D(2, 1199)	...	D(X, 1199)	...	D(1599, 1199)	D(1600, 1199)
D(1, 1200)	D(2, 1200)	...	D(X, 1200)	...	D(1599, 1200)	D(1600, 1200)

4.10 TEN-bit LOOK UP TABLE FOR GAMMA ADJUSTMENT

Adjustment of gamma characteristics for each 8-bit RGB color data is possible by using built-in 10-bit LUT (look up table) for Gamma characteristics.

The LUT is set with the serial data. The combination of the control command determines the R/W actions.: READ, Random/Sequential Address WRITE and Individual/Simultaneous RGB setting.

The serial data is composed as Table 1.

Table1: Serial data Composition

DATA	DATA name	Function	Remarks
D31	CMD5	Control Command	See Table2 and 3.
D30	CMD4	Control Command	
D29	CMD3	Control Command	
D28	CMD2	Control Command	
D27	CMD1	Control Command	
D26	CMD0	Control Command	
D25	ADD9	LUT Address (MSB)	See Table4.
D24	ADD8	LUT Address	
D23	ADD7	LUT Address	
D22	ADD6	LUT Address	
D21	ADD5	LUT Address	
D20	ADD4	LUT Address	
D19	ADD3	LUT Address	
D18	ADD2	LUT Address	
D17	ADD1	LUT Address	
D16	ADD0	LUT Address (LSB)	
D15	Dummy	Dummy Data "0"	See Table5.
D14	Dummy	Dummy Data "0"	
D13	Dummy	Dummy Data "0"	
D12	Dummy	Dummy Data "0"	
D11	Dummy	Dummy Data "0"	
D10	Dummy	Dummy Data "0"	
D9	DATA9	LUT Data (MSB)	
D8	DATA8	LUT Data	
D7	DATA7	LUT Data	
D6	DATA6	LUT Data	
D5	DATA5	LUT Data	
D4	DATA4	LUT Data	
D3	DATA3	LUT Data	
D2	DATA2	LUT Data	
D1	DATA1	LUT Data	
D0	DATA0	LUT Data (LSB)	

Table2: Command table (CMD5 to CMD0: 6-bit)

DATA name	Parameter	Remarks
CMD5	Selection of WRITE/READ mode "1": WRITE mode "0": READ mode	In case of "0", must be set as follows. CMD4: "1", CMD3: "0", CMD2: "1" CMD1: "0", CMD0: "0"
CMD4	Must be set to "1".	-
CMD3	Selection of Random/Sequential Address WRITE "1": Random Address WRITE "0": Sequential Address WRITE	-
CMD2	Must be set to "1".	-
CMD1	Selection of Individual/Simultaneous RGB setting "1": Individual RGB setting "0": Simultaneous RGB setting	"1": Select the color by using ADD9 and ADD8. (See Table4.) "0": ADD9 and ADD8 are invalid.
CMD0	Must be set to "0".	-

Table3: Command Combination table (CMD5 to CMD0: 6-bit)

CMD5	CMD4	CMD3	CMD2	CMD1	CMD0	Mode
1	1	1	1	1	0	Random Address WRITE, Individual RGB setting
1	1	1	1	0	0	Random Address WRITE, Simultaneous RGB setting
1	1	0	1	1	0	Sequential Address WRITE, Individual RGB setting
1	1	0	1	0	0	Sequential Address WRITE, Simultaneous RGB setting
0	1	0	1	0	0	READ mode

*Other combinations are prohibited, and may cause function error.

Table4: Address table (ADD9 to ADD0: 10-bit)

DATA name	Parameter	Remarks
ADD9	Color Selection ADD[9:8]= 0:0 Red 0:1 Green 1:0 Blue 1:1 ON/OFF selection of Gamma Correction	When "ADD[9:8]=1:1", ON/OFF of Gamma correction can select according to the GMA[2:0]. (See Table6 and Table7.)
ADD8		
ADD7		
ADD6		
ADD5	LUT Address 256 address = 00h - FFh	When ADD[9:8] = 1:1, ADD[7:0] must be set to 00h.
ADD4		
ADD3		
ADD2		
ADD1		
ADD0		

Table5: Data table (DATA15 to DATA0: 16-bit)

DATA	DATA name	Parameter	Remarks
DATA15	Dummy	Dummy Data Must be set to "0".	-
DATA14	Dummy		
DATA13	Dummy		
DATA12	Dummy		
DATA11	Dummy		
DATA10	Dummy		
DATA9	DATA9	[MSB]	-
DATA8	DATA8	10-bit LUT Data 000h - 3FFh	
DATA7	DATA7		
DATA6	DATA6		
DATA5	DATA5		
DATA4	DATA4		
DATA3	DATA3		
DATA2	DATA2		
DATA1	DATA1		
DATA0	DATA0	[LSB]	

Table6: Gamma correction table (DATA15 to DATA0: 16bit)

DATA	DATA name	Parameter	Remarks
DATA15	Dummy	Dummy Data Must be set to "0".	-
DATA14	Dummy		
DATA13	Dummy		
DATA12	Dummy		
DATA11	Dummy		
DATA10	Dummy		
DATA9	Dummy		
DATA8	Dummy		
DATA7	Dummy		
DATA6	Dummy		
DATA5	Dummy		
DATA4	Dummy		
DATA3	Dummy	[MSB] GMA Data	See Table7.
DATA2	GMA2		
DATA1	GMA1		
DATA0	GMA0	[LSB]	

Table7: Control code GMA[2:0]

GMA2	GMA1	GMA0	Function
0	0	0	No correction (Initial setting)
0	0	1	Correction according to the LUT Data. Note1

*Other combinations are prohibited, and may cause function error.

Note1: Initial setting of the LUT is undefined data. The LUT should be enabled by setting of the GMA after writing the LUT data in all the 256 addresses, in order to avoid undefined data display.

Note2: Transfer the data every power-on, because the LUT data isn't stored in the LCD module.

Note3: As writing and reading the LUT data, a noise may appear on the display image. In order to prevent the noise appearing on the display, following measures should be performed.

(1) The LUT data should be rewritten during invalid period of pixel data (See "4.8 INPUT SIGNAL TIMINGS").

(2) The LUT data should be rewritten when the Gamma Correction is OFF (GMA[2:0]= 000).

4.11 LUT SERIAL COMMUNICATION TIMINGS

4.11.1 Timing Chart

(1) READ Timing Chart

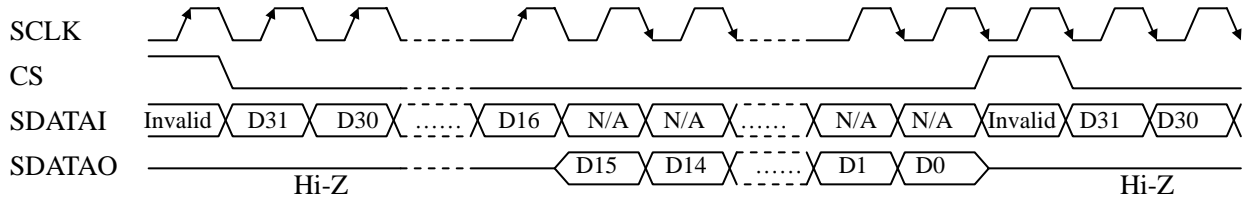

(2) Random Address WRITE Timing Chart

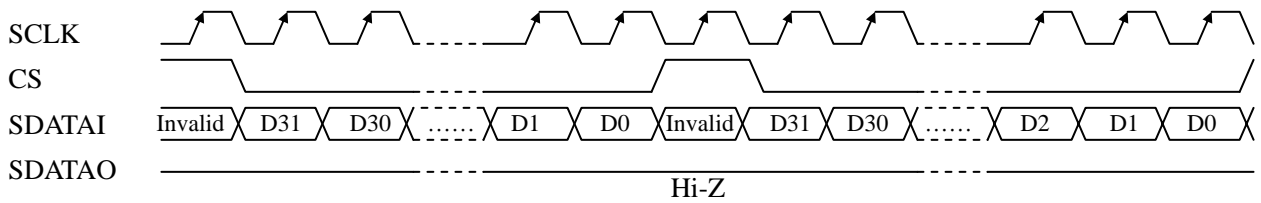

(3) Sequential Address WRITE Timing Chart

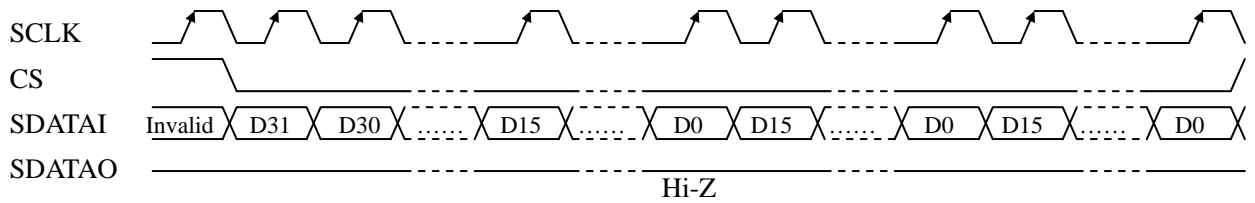

4.11.2 Timing specifications

Parameter	Symbol	min.	typ.	max.	Unit	Remarks
SCLK Frequency	1/Tsck	-	-	5	MHz	-
SCLK Pulse Width (WRITE)	Twscck	50	-	-	ns	-
SCLK Pulse Width (READ)	Twscck	5	-	-	tc	Note1
SDATI-SCLK Setup Time	Tds	50	-	-	ns	-
SDATI-SCLK Hold Time	Tdh	50	-	-	ns	-
CS-SCLK Setup Time	Tcs	50	-	-	ns	-
CS-SCLK Hold Time	Tch	50	-	-	ns	-

Note1: At the READ of the serial communication mode, the SCLK Pulse Width (Twscck) must be greater than 5CLK (5 tc's). (See "4.8.1 Timing characteristics".)

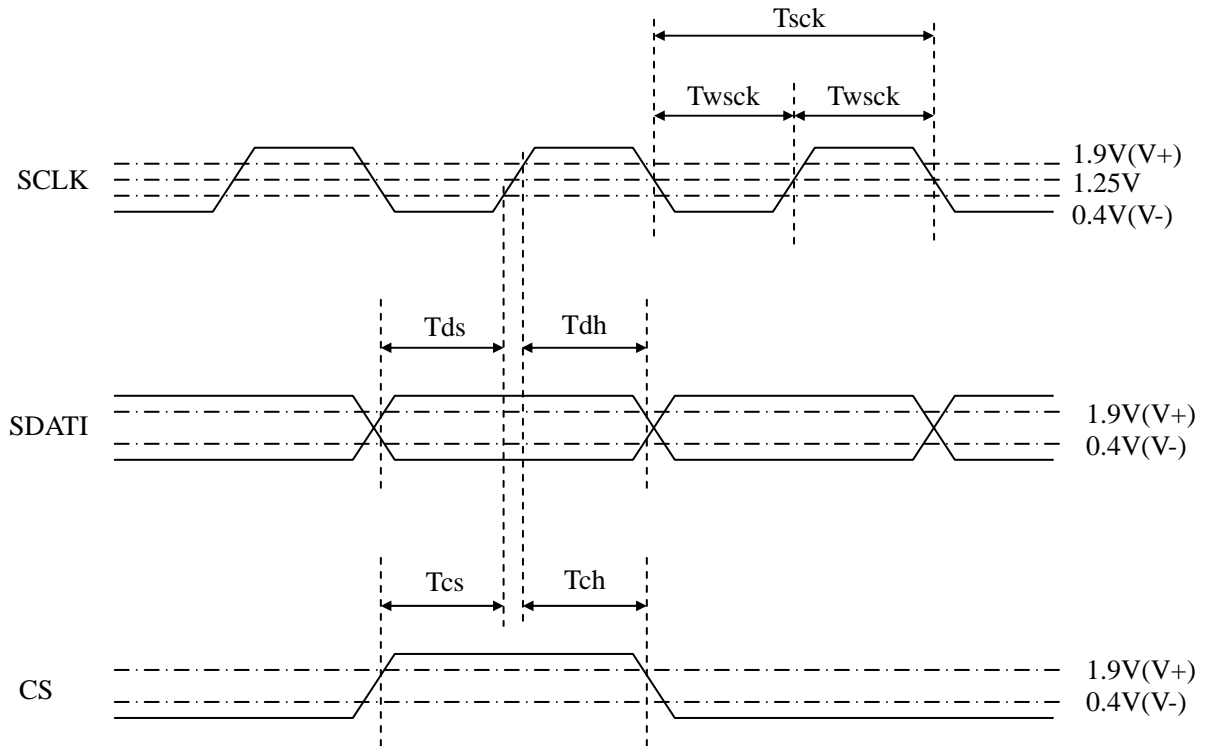

Note2: During the serial communication mode, the display noise may appear because of rewriting the data. To avoid this, rewrite the LUT data when the pixel data is invalid or the Gamma Correction is OFF ($GMA[2:0] = 000$). The external noise may cause the data change, refresh the data regularly according to need.

4.12 OPTICS

4.12.1 Optical characteristics

(Note1, Note2)

Parameter	Condition	Symbol	min.	typ.	max.	Unit	Measuring instrument	Remarks	
Luminance	White at center $\theta_R = 0^\circ, \theta_L = 0^\circ, \theta_U = 0^\circ, \theta_D = 0^\circ$	L	200	250	-	cd/m ²	BM-5A or SR-3	-	
Contrast ratio	White/Black at center $\theta_R = 0^\circ, \theta_L = 0^\circ, \theta_U = 0^\circ, \theta_D = 0^\circ$	CR	400	550	-	-	BM-5A or SR-3	Note3	
Luminance uniformity	White $\theta_R = 0^\circ, \theta_L = 0^\circ, \theta_U = 0^\circ, \theta_D = 0^\circ$	LU	-	1.15	1.3	-	BM-5A	Note4	
Chromaticity	White	x coordinate	Wx	-	0.313	-	-	SR-3	Note5
		y coordinate	Wy	-	0.329	-	-		
	Red	x coordinate	Rx	-	0.65	-	-		
		y coordinate	Ry	-	0.33	-	-		
	Green	x coordinate	Gx	-	0.29	-	-		
		y coordinate	Gy	-	0.61	-	-		
Blue	x coordinate	Bx	-	0.14	-	-			
	y coordinate	By	-	0.079	-	-			
Color gamut	$\theta_R = 0^\circ, \theta_L = 0^\circ, \theta_U = 0^\circ, \theta_D = 0^\circ$ at center, against NTSC color space	C	65	72	-	%			
Response time	Black to White	Ton	-	11	20	ms	BM-5A	Note6	
	White to Black	Toff	-	9	20	ms		Note7	
Viewing angle	Right	$\theta_U = 0^\circ, \theta_D = 0^\circ, CR \geq 10$	θ_R	70	85	-	BM-5A	Note8	
	Left	$\theta_U = 0^\circ, \theta_D = 0^\circ, CR \geq 10$	θ_L	70	85	-			
	Up	$\theta_R = 0^\circ, \theta_L = 0^\circ, CR \geq 10$	θ_U	70	85	-			
	Down	$\theta_R = 0^\circ, \theta_L = 0^\circ, CR \geq 10$	θ_D	70	85	-			

Note1: These are initial characteristics.

Note2: Measurement conditions are as follows.

Ta= 25°C, VDD= 12.0V, IBL= 6.0mArms/lamp, Display mode: UXGA,
Horizontal cycle= 1/75.19kHz, Vertical cycle= 1/60.0Hz

Optical characteristics are measured at luminance saturation after 20 minutes from working the product, in the dark room. Also measurement methods are as follows.

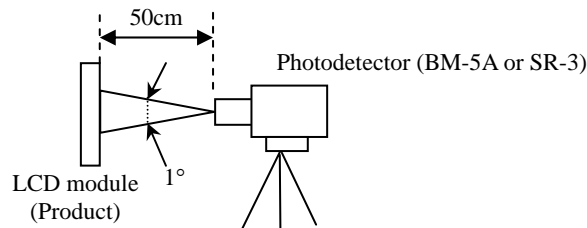

Note3: See "4.12.2 Definition of contrast ratio".

Note4: See "4.12.3 Definition of luminance uniformity".

Note5: These coordinates are found on CIE 1931 chromaticity diagram.

Note6: Product surface temperature: TopF= 35°C

Note7: See "4.12.4 Definition of response times".

Note8: See "4.12.5 Definition of viewing angles".

4.12.2 Definition of contrast ratio

The contrast ratio is calculated by using the following formula.

$$\text{Contrast ratio (CR)} = \frac{\text{Luminance of white screen}}{\text{Luminance of black screen}}$$

4.12.3 Definition of luminance uniformity

The luminance uniformity is calculated by using following formula.

$$\text{Luminance uniformity (LU)} = \frac{\text{Maximum luminance from ① to ⑤}}{\text{Minimum luminance from ① to ⑤}}$$

The luminance is measured at near the 5 points shown below.

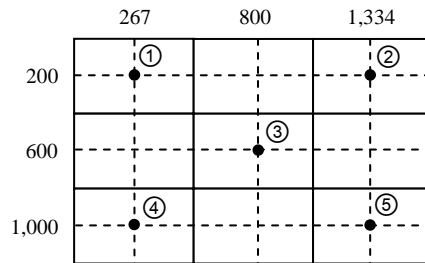

4.12.4 Definition of response times

Response time is measured, the luminance changes from "black" to "white", or "white" to "black" on the same screen point, by photo-detector. Ton is the time it takes the luminance change from 10% up to 90%. Also Toff is the time it takes the luminance change from 90% down to 10% (See the following diagram.).

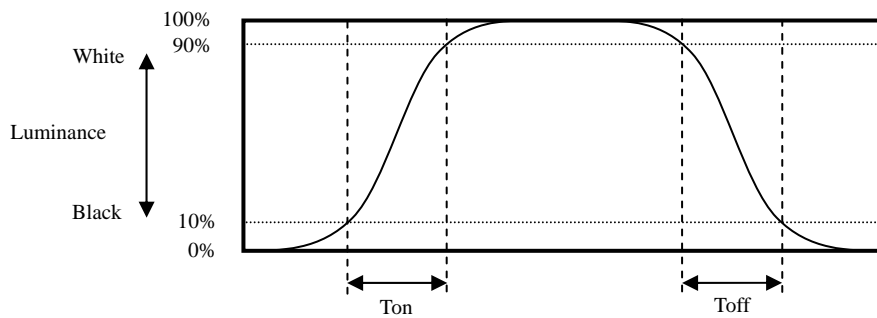

4.12.5 Definition of viewing angles

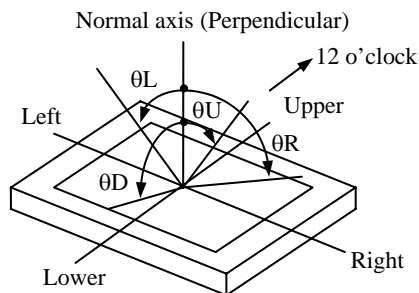

5. RELIABILITY TESTS

(Note1)

Test item	Condition	Judgment
High temperature and humidity (Operation)	① 60 ± 2°C, RH= 60%, 240hours ② Display data is white.	No display malfunctions
Heat cycle (Operation)	① 0 ± 3°C...1hour 55 ± 3°C...1hour ② 50cycles, 4hours/cycle ③ Display data is white.	
Thermal shock (Non operation)	① -20 ± 3°C...30minutes 60 ± 3°C...30minutes ② 100cycles, 1hour/cycle ③ Temperature transition time is within 5 minutes.	
Vibration (Non operation)	① 5 to 100Hz, 11.76m/s ² ② 1 minute/cycle ③ X, Y, Z direction ④ 10 times each directions	No display malfunctions No physical damages
Mechanical shock (Non operation)	① 294m/ s ² , 11ms ② X, Y, Z direction ③ 3 times each directions	
ESD (Operation)	① 150pF, 150Ω, ±10kV ② 9 places on a panel surface Note2 ③ 10 times each places at 1 sec interval	No display malfunctions
Dust (Operation)	① Sample dust: No.15 (by JIS-Z8901) ② 15 seconds stir ③ 8 times repeat at 1 hour interval	
Low pressure	Non-operation	No display malfunctions
	Operation	
	① 15kPa (Equivalent to altitude 13,600m) ② -20°C±3°C...24 hours ③ +60°C±3°C...24 hours	
	① 53.3kPa (Equivalent to altitude 4,850m) ② 0°C±3°C...24 hours ③ +55°C±3°C...24 hours	

Note1: Display and appearance are checked under environmental conditions equivalent to the inspection conditions of defect criteria.

Note2: See the following figure for discharge points

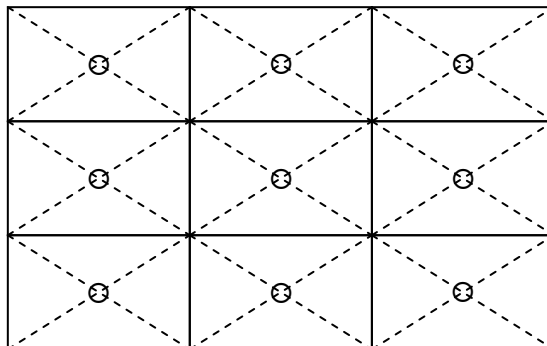

6. PRECAUTIONS

6.1 MEANING OF CAUTION SIGNS

The following caution signs have very important meaning. **Be sure to read "6.2 CAUTIONS" and "6.3 ATTENTIONS", after understanding these contents!**

	This sign has the meaning that customer will be injured by himself or the product will sustain a damage, if customer has wrong operations.
	This sign has the meaning that customer will get an electrical shock, if customer has wrong operations.
	This sign has the meaning that customer will be injured by himself, if customer has wrong operations.

6.2 CAUTIONS

*** Do not touch the working backlight. There is a danger of an electric shock.**

*** Do not touch the working backlight. There is a danger of burn injury.**
*** Do not shock and press the LCD panel and the backlight! There is a danger of breaking, because they are made of glass. (Shock: To be not greater 294m/s² and to be not greater 11ms, Pressure: To be not greater 19.6N (φ16mm jig))**

6.3 ATTENTIONS

6.3.1 Handling of the product

- ① Take hold of both ends without touching the circuit board when the product (LCD module) is picked up from inner packing box to avoid broken down or misadjustment, because of stress to mounting parts on the circuit board.
- ② Do not hook nor pull cables such as lamp cable, and so on, in order to avoid any damage.
- ③ When the product is put on the table temporarily, display surface must be placed downward.
- ④ When handling the product, take the measures of electrostatic discharge with such as earth band, ionic shower and so on, because the product may be damaged by electrostatic.
- ⑤ The torque for product mounting screws must never exceed 0.735N·m. Higher torque might result in distortion of the bezel. And the length of product mounting screws must be ≤ 5.3mm.

- ⑥ The product must be installed using mounting holes without undue stress such as bends or twist (See outline drawings). And do not add undue stress to any portion (such as bezel flat area). Bends or twist described above and undue stress to any portion may cause display mura.
Recommended installing method: Ideal plane "A" is defined by one mounting hole (datum point) and other mounting holes. The ideal plane "A" should be the same plane within $\pm 0.3\text{mm}$.

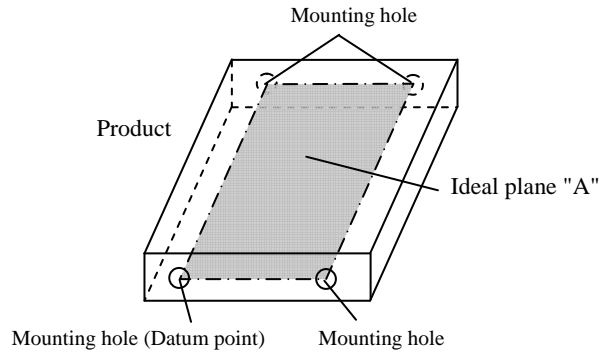

- ⑦ Do not press or rub on the sensitive product surface. When cleaning the product surface, use of the cloth with ethanolic liquid such as screen cleaner for LCD is recommended.
- ⑧ Do not push nor pull the interface connectors while the product is working.
- ⑨ If the lamp cable is attached on the metal part of the product directly, high frequency leak current to the metal part may occur, then the brightness may decrease or the lamp may not be turned on.
- ⑩ When handling the product, use of an original protection sheet on the product surface (polarizer) is recommended for protection of product surface. Adhesive type protection sheet may change color or characteristics of the polarizer.

6.3.2 Environment

- ① Do not operate or store in high temperature, high humidity, dewdrop atmosphere or corrosive gases. Keep the product in packing box with antistatic pouch in room temperature to avoid dusts and sunlight, when storing the product.
- ② In order to prevent dew condensation occurring by temperature difference, the product packing box should be opened after enough time being left under the environment of an unpacking room. Evaluate the leaving time sufficiently because a situation of dew condensation occurring is changed by the environmental temperature and humidity. (Recommended leaving time: 6 hours or more with packing state)
- ③ Do not operate in high magnetic field. Circuit boards may be broken down by it.
- ④ This product is not designed as radiation hardened.

6.3.3 Characteristics

The following items are neither defects nor failures.

- ① Response time, luminance and color may be changed by ambient temperature.
- ② Display mura, flicker, vertical seam or small spot may be observed depending on display patterns.
- ③ Optical characteristics (e.g. luminance, display uniformity, etc.) gradually is going to change depending on operating time, and especially low temperature, because the LCD has cold cathode fluorescent lamps.
- ④ Do not display the fixed pattern for a long time because it may cause image sticking. Use a screen saver, if the fixed pattern is displayed on the screen.
- ⑤ The display color may be changed depending on viewing angle because of the use of condenser sheet in the backlight.
- ⑥ Optical characteristics may be changed depending on input signal timings.
- ⑦ The interference noise between input signal frequency for this product's signal processing board and luminance control frequency of the inverter may appear on a display. Set up luminance control frequency of the inverter so that the interference noise does not appear.

6.3.4 Other

- ① All GND and VDD terminals should be used without any non-connected lines.
- ② Do not disassemble a product or adjust variable resistors
- ③ Pack the product with original shipping package, in order to avoid any damages during transportation, when returning the product to NEC for repair and so on.
- ④ The LCD module by itself or integrated into end product should be packed and transported with display in the vertical position. Otherwise the display characteristics may be degraded.

7. OUTLINE DRAWINGS

7.1 FRONT VIEW

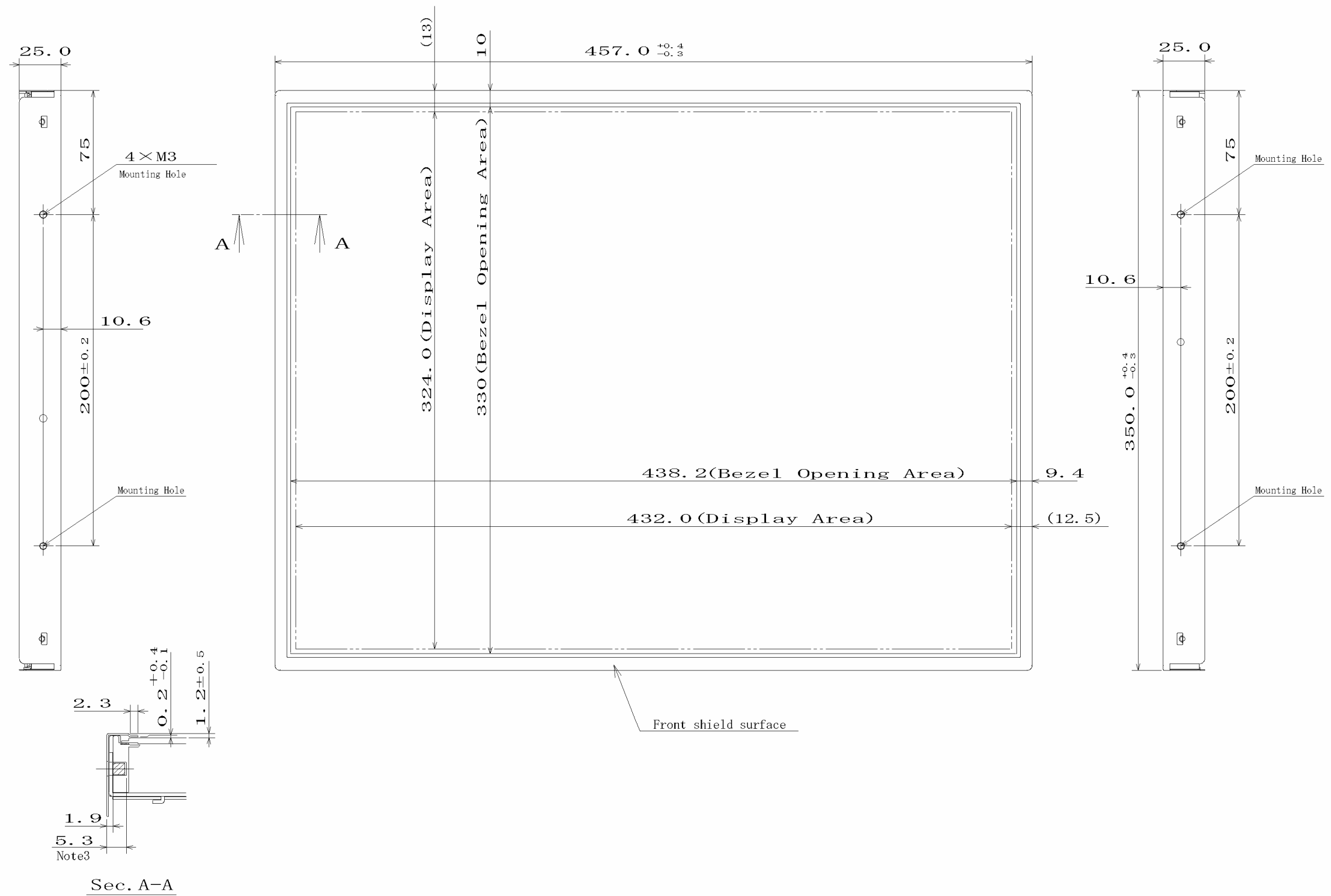

- Note1: Not shown tolerances of the dimensions are ± 0.3 mm.
- Note2: The torque for product mounting screws must never exceed 0.735N·m.
- Note3: The length of product mounting screws from surface of plate must be ≤ 5.3 mm.
- Note4: The values in parentheses are for reference.

Unit: mm

7.2 REAR VIEW

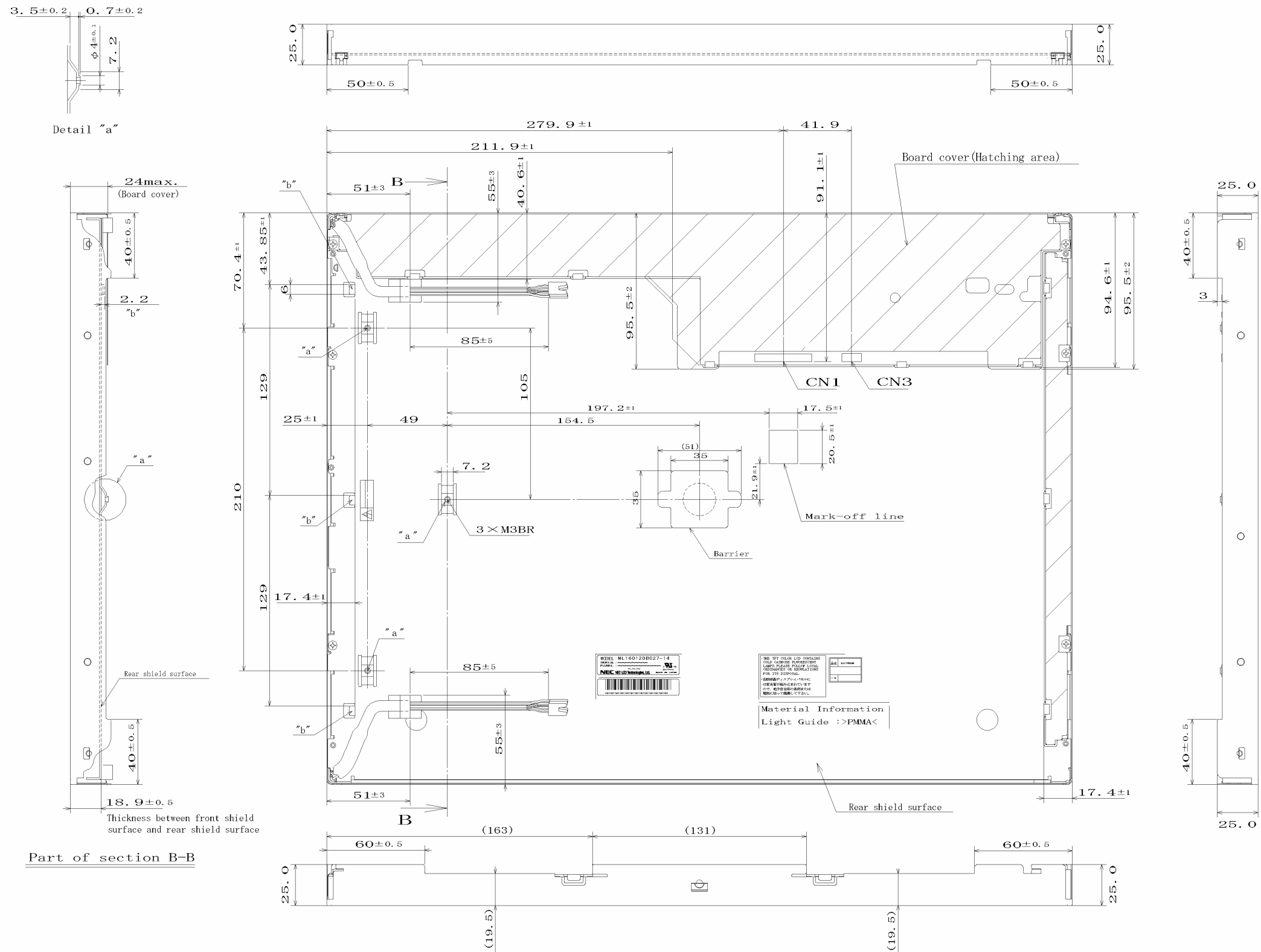

- Note1: Not shown tolerances of the dimensions are ±0.3mm.
- Note2: The torque for product mounting screws must never exceed 0.735N·m.
- Note3: The values in parentheses are for reference.

Unit: mm