

NEC NEC LCD Technologies, Ltd.

TFT MONOCHROME LCD MODULE

NL256204AM15-01

NL256204AM15-01A

51cm (20.1 Type)

QSXGA

LVDS Interface (4 ports)

DATA SHEET

DOD-PD-0887 (4th edition)

**This DATA SHEET is updated document from
DOD-PD-0561(3).**

**All information is subject to change without notice.
Please confirm the sales representative before
starting to design your system.**

INTRODUCTION

No part of this document shall be copied in any form or by any means without the prior written consent of NEC LCD Technologies, Ltd. (hereinafter called "NEC").

NEC does not assume any liability for infringement of patents, copyrights or other intellectual property rights of third parties by or arising from use of a product described herein or any other liability arising from use of such application. No license, express, implied or otherwise, is granted under any patents, copyrights or other intellectual property rights of NEC or of others.

While NEC has been making continuous effort to enhance the reliability of its products, the possibility of failures cannot be eliminated entirely. To minimize risks of damage to property or injury to person arising from a failure in an NEC product, customers must incorporate sufficient safety measures in their design, such as redundancy, fire-containment and anti-failure features.

NEC products are classified into the following three quality grades:

"Standard", "Special", "Specific"

The **"Specific"** quality grade applies only to applications developed based on a customer designated "quality assurance program" for a specific application. The recommended applications of a product depend on its quality grade, as indicated below. Customers must check the quality grade of each application before using it in a particular application.

Standard: Computers, office equipment, communications equipment, test and measurement equipment, audio and visual equipment, home electronic appliances, machine tools, personal electronic equipment and industrial robots

Special: Transportation equipment (automobiles, trains, ships, etc.), traffic control systems, anti-disaster systems, anti-crime systems, safety equipment and medical equipment (not specifically designed for life support)

Specific: Military systems, aircraft, aerospace equipment, submersible repeaters, nuclear reactor control systems, life support systems (medical equipment, etc.) and any other equipment

The quality grade of this product is **"Standard"** unless otherwise specified in this document. If customers intend to use this product for applications other than those specified for **"Standard"** quality grade, they should contact NEC sales representative in advance.

CONTENTS

INTRODUCTION	2
1. OUTLINE.....	4
1.1 STRUCTURE AND PRINCIPLE.....	4
1.2 APPLICATION.....	4
1.3 FEATURES.....	4
2. GENERAL SPECIFICATIONS	5
3. BLOCK DIAGRAM.....	6
4. DETAILED SPECIFICATIONS	7
4.1 MECHANICAL SPECIFICATIONS.....	7
4.2 ABSOLUTE MAXIMUM RATINGS	7
4.3 ELECTRICAL CHARACTERISTICS.....	8
4.3.1 LCD panel signal processing board	8
4.3.2 Inverter.....	9
4.3.3 Inverter current wave	9
4.3.4 Power supply voltage ripple.....	10
4.3.5 Fuse.....	10
4.4 POWER SUPPLY VOLTAGE SEQUENCE	11
4.4.1 LCD panel signal processing board	11
4.4.2 Inverter.....	11
4.5 CONNECTIONS AND FUNCTIONS FOR INTERFACE PINS.....	12
4.5.1 LCD panel signal processing board	12
4.5.2 Inverter.....	15
4.5.3 Positions of socket	15
4.6 LUMINANCE CONTROL.....	16
4.6.1 Luminance control methods.....	16
4.6.2 Detail of PWM timing	17
4.7 METHOD OF CONNECTION FOR LVDS TRANSMITTER.....	18
4.8 DISPLAY GRAY SCALE AND INPUT DATA SIGNALS.....	20
4.9 INPUT SIGNAL TIMINGS.....	21
4.9.1 Timing characteristics	21
4.9.2 Input signal timing chart	21
4.10 LVDS DATA TRANSMISSION MODE	22
4.11 DISPLAY POSITIONS.....	23
4.12 PIXEL ARRANGMENT	24
4.13 TEN-bit LOOK UP TABLE FOR GAMMA ADJUSTMENT.....	25
4.14 LUT SERIAL COMMUNICATION TIMINGS	28
4.15 OPTICS.....	30
4.15.1 Optical characteristics.....	30
4.15.2 Definition of contrast ratio	32
4.15.3 Definition of luminance uniformity	32
4.15.4 Definition of response times	32
4.15.5 Definition of viewing angles.....	32
5. RELIABILITY TESTS.....	33
6. PRECAUTIONS	34
6.1 MEANING OF CAUTION SIGNS	34
6.2 CAUTIONS	34
6.3 ATTENTIONS	34
6.3.1 Handling of the product	34
6.3.2 Environment.....	35
6.3.3 Characteristics.....	36
6.3.4 Other	36
7. OUTLINE DRAWINGS	37

1. OUTLINE

1.1 STRUCTURE AND PRINCIPLE

Monochrome LCD module NL256204AM15-01 and NL256204AM15-01A are composed of the amorphous silicon thin film transistor liquid crystal display (a-Si TFT LCD) panel structure with driver LSIs for driving the TFT (Thin Film Transistor) array and a backlight.

The a-Si TFT LCD panel structure is injected liquid crystal material into a narrow gap between the TFT array glass substrate and a monochrome-filter glass substrate.

Grayscale data signals from a host system (e.g. PC, signal generator, etc.) are modulated into best form for active matrix system by a signal processing board, and sent to the driver LSIs which drive the individual TFT arrays.

The TFT array as an electro-optical switch regulates the amount of transmitted light from the backlight assembly, when it is controlled by data signals. Monochrome images are created by regulating the amount of transmitted light through the TFT array.

1.2 APPLICATION

- Monochrome monitor system

1.3 FEATURES

- Ultra-wide viewing angle (Adoption of Super Advanced -Super Fine TFT (SA-SFT))
- High luminance
- High contrast
- Low reflection
- High resolution
- 256 gray scales per 1 sub-pixel
- LVDS interface
- Adjustable gamma characteristics by using built-in 10-bit LUT (look up table)
- Selectable LVDS data input map
- Selectable LVDS data transmission mode
- Small foot print
- Incorporated direct type backlight
- Replaceable backlight unit and inverter
- Differences between NL256204AM15-01 and NL256204AM15-01A

Item	NL256204AM15-01	NL256204AM15-01A
White chromaticity	$W_x, W_y = (0.255, 0.310)$ (typ.)	$W_x, W_y = (0.280, 0.304)$ (typ.)
Backlight unit (Replaceable part)	201LHS07	201LHS08

2. GENERAL SPECIFICATIONS

Display area	399.36 (H) × 319.488 (V) mm	
Diagonal size of display	51 cm (20.1 inches)	
Drive system	a-Si TFT active matrix	
Display gray scale	256 gray scales per 1 sub-pixel (8-bit) (766 gray scales per 1 pixel)	
Pixel	2,560 (H) × 2,048 (V) pixels (1 pixel consists of 3 sub pixels (LCR))	
Pixel arrangement	LCR Vertical stripe	
Sub-pixel pitch	0.052 (H) × 0.156 (V) mm	
Pixel pitch	0.156 (H) × 0.156 (V) mm	
Module size	423.4 (W) × 343.5 (H) × 43.5 (D) mm (typ.)	
Weight	2,440 g (typ.)	
Contrast ratio	600:1 (typ.)	
Viewing angle	At the contrast ratio $\geq 10:1$ <ul style="list-style-type: none"> • Horizontal: Right side 85° (typ.), Left side 85° (typ.) • Vertical: Up side 85° (typ.), Down side 85° (typ.) 	
Designed viewing direction	Viewing angle with optimum grayscale (γ =DICOM): normal axis Note1	
Polarizer surface	Antiglare	
Polarizer pencil-hardness	2H (min.) [by JIS K5400]	
Response time	Ton + Toff (10% \leftrightarrow 90%) 30 ms (typ.)	
Luminance	At the maximum luminance control 850 cd/m ² (typ.)	
White chromaticity	NL256204AM15-01	Wx, Wy = (0.255, 0.310) (typ.)
	NL256204AM15-01A	Wx, Wy = (0.280, 0.304) (typ.)
Signal system	4 ports LVDS interface LCR 8-bit signals, Data enable signal (DE), Dot clock (CLK)	
Power supply voltage	LCD panel signal processing board: 12.0V Inverter: 12.0V	
Backlight	Direct light type: 12 cold cathode fluorescent lamps with an inverter	
	NL256204AM15-01	Replaceable parts <ul style="list-style-type: none"> • Backlight unit: Type No.: 201LHS07 • Inverter: Type No.: 201PW121
	NL256204AM15-01A	Replaceable parts <ul style="list-style-type: none"> • Backlight unit: Type No.: 201LHS08 • Inverter: Type No.: 201PW121
Power consumption	At checkered flag pattern and the maximum luminance control 49.2 W (typ.)	

Note1: When the product luminance is 850cd/m², the gamma characteristic is designed to γ =DICOM.

NEC NEC LCD Technologies, Ltd.

NL256204AM15-01/01A

3. BLOCK DIAGRAM

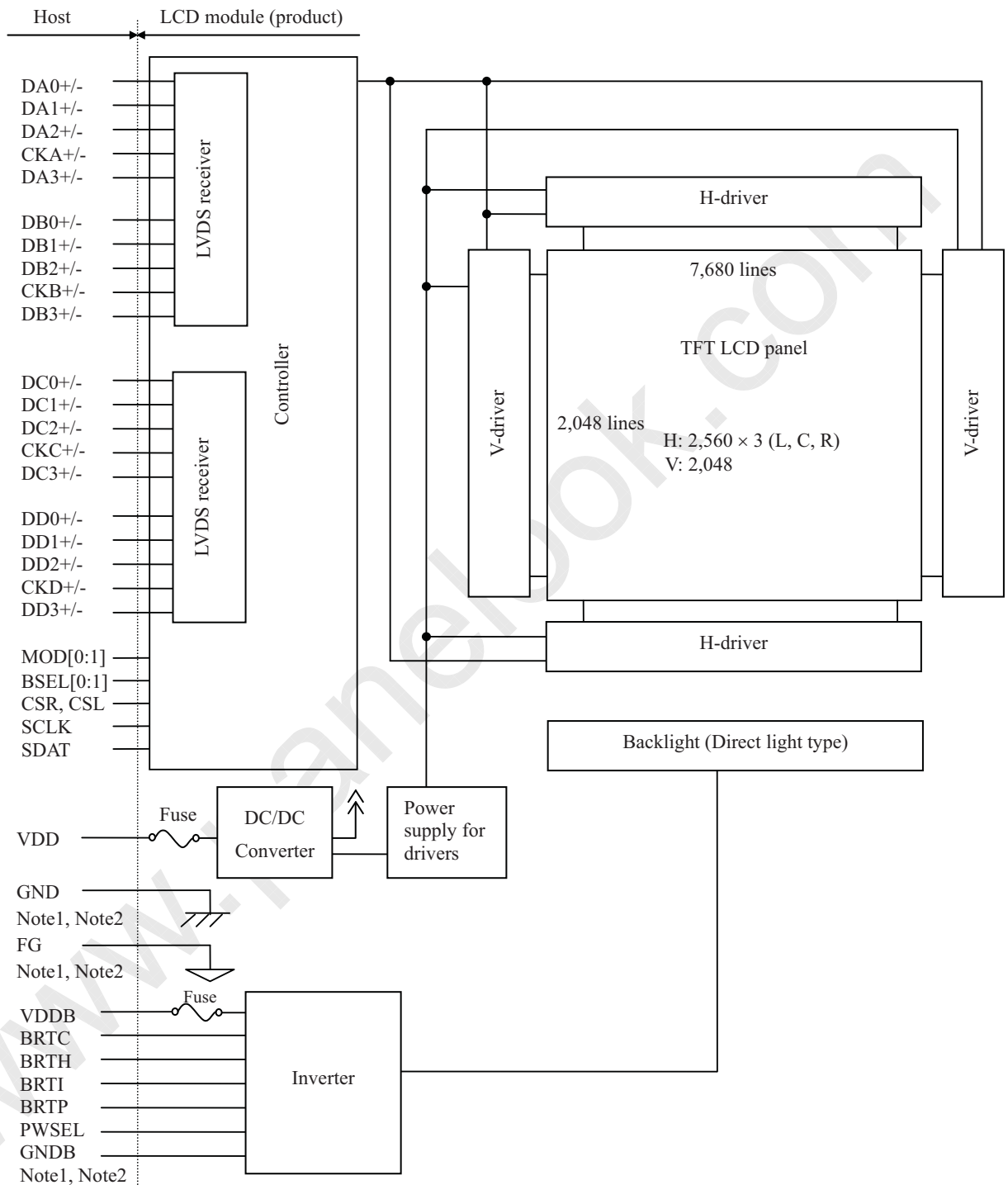

Note1: Connections between GND (Signal ground), FG (Frame ground) and GNDB (Inverter ground) in the LCD module

GND - FG	Not connected
GND - GNDB	Not connected
FG - GNDB	Not connected

Note2: GND, FG and GNDB must be connected to customer equipment's ground, and it is recommended that these grounds are connected together in customer equipment.

4. DETAILED SPECIFICATIONS

4.1 MECHANICAL SPECIFICATIONS

Parameter	Specification	Unit
Module size	423.4 ± 1.0 (W) × 343.5 ± 1.0 (H) × 43.5 ± 1.0 (D) Note1	mm
Display area	399.36 (H) × 319.488 (V) Note1	mm
Weight	2,440 (typ.), 2,600 (max.)	g

Note1: See "7. OUTLINE DRAWINGS".

4.2 ABSOLUTE MAXIMUM RATINGS

Parameter		Symbol	Rating	Unit	Remarks	
Power supply voltage		LCD panel signal processing board	VDD	-0.3 to +15.0	V	Ta = 25°C
		Inverter	VDDDB	-0.3 to +15.0	V	
Input voltage for signals	LCD panel signal processing board	Display signals Note1	VD	-0.3 to +3.6	V	Ta = 25°C VDD=12.0V
		Function signal 1 Note2	VF1	-0.3 to +3.9		
		Function signal 2 Note3	VF2			
	Inverter	BRTI signal	VBI	-0.3 to +1.5	V	Ta = 25°C VDDDB = 12.0V
		BRTP signal	VBP	-0.3 to +5.5	V	
		BRTC signal	VBC	-0.3 to +5.5	V	
		PWSEL signal	VPSL	-0.3 to +5.5	V	
Storage temperature		Tst	-20 to +60	°C	-	
Operating temperature	Front surface	TopF	0 to +55	°C	Note4	
	Rear surface	TopR	0 to +55	°C	Note5	
Relative humidity Note6		RH	≤ 95	%	Ta ≤ 40°C	
			≤ 85	%	40 < Ta ≤ 50°C	
			≤ 70	%	50 < Ta ≤ 55°C	
Absolute humidity Note6		AH	≤ 73 Note7	g/m ³	Ta > 55°C	

Note1: DA0+/-, DA1+/-, DA2+/-, DA3+/-, CKA+/-, DB0+/-, DB1+/-, DB2+/-, DB3+/-, CKB+/-, DC0+/-, DC1+/-, DC2+/-, DC3+/-, CKC+/-, DD0+/-, DD1+/-, DD2+/-, DD3+/-, CKD+/-

Note2: MOD0, MOD1, BSEL0, BSEL1

Note3: CSR, CSL, SCLK, SDAT

Note4: Measured at center of LCD panel surface (including self-heat)

Note5: Measured at center of LCD module's rear shield surface (including self-heat)

Note6: No condensation

Note7: Water amount at Ta = 55°C and RH = 70%

4.3 ELECTRICAL CHARACTERISTICS

4.3.1 LCD panel signal processing board

(Ta = 25°C)

Parameter	Symbol	min.	typ.	max.	Unit	Remarks	
Power supply voltage	VDD	10.8	12.0	13.2	V	-	
Power supply current	IDD	-	900 Note1	1,800 Note2	mA	at VDD = 12.0V, Mode 0 is selected.	
Differential input threshold voltage for Display signals	High	VTH	-	-	+100	mV	at VCM= 1.2V Note3, Note4
	Low	VTL	-100	-	-	mV	
Input voltage swing	VI	0	-	2.4	V	Note4	
Terminating resistance	RT	-	100	-	Ω	-	
Input voltage for Function signal 1	High	VFH1	High must be Open.			-	Note5
	Low	VFL1	0	-	0.8	V	
Input current for Function signal 1	Low	IFL1	-10	-	10	μA	
Input voltage for Function signal 2	High	V+	-	-	2.3	V	Note6
	Low	V-	0.5	-	-	V	
	Hysteresis	VH	0.4	-	-	V	

Note1: Checkered flag pattern [by EIAJ ED-2522]

Note2: Pattern for maximum current

Note3: Common mode voltage for LVDS receiver

Note4: DA0+/-, DA1+/-, DA2+/-, DA3+/-, CKA+/-, DB0+/-, DB1+/-, DB2+/-, DB3+/-, CKB+/-, DC0+/-, DC1+/-, DC2+/-, DC3+/-, CKC+/-, DD0+/-, DD1+/-, DD2+/-, DD3+/-, CKD+/-.

Note5: MOD0, MOD1, BSEL0, BSEL1

Note6: CSR, CSL, SCLK, SDAT

4.3.2 Inverter

(Ta = 25°C)

Parameter		Symbol	min.	typ.	max.	Unit	Remarks
Power supply voltage		VDDB	11.4	12.0	12.6	V	-
Power supply current		IDDB	-	3,200	4,000	mA	VDDB = 12.0V, At the maximum luminance control
Input voltage for signals	BRTI signal		VBI	0	-	1.0	V
	BRTP signal	High	VBPH	2.0	-	5.25	V
		Low	VBPL	0	-	0.8	V
	BRTC signal	High	VBCH	2.0	-	5.25	V
		Low	VBCL	0	-	0.8	V
	PWSEL signal	High	VPSLH	2.0	-	5.25	V
Low		VPSLL	0	-	0.8	V	
Input current for signals	BRTI signal		IBI	-130	-	-	μA
	BRTP signal	High	IBPH	-	-	3.5	mA
		Low	IBPL	-1.6	-	-	mA
	BRTC signal	High	IBCH	-	-	440	μA
		Low	IBCL	-610	-	-	μA
	PWSEL signal	High	IPSLH	-	-	440	μA
Low		IPSLL	-610	-	-	μA	

4.3.3 Inverter current wave

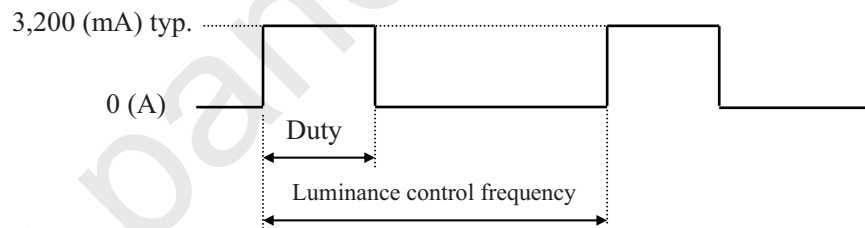

Maximum luminance control: 100%

Minimum luminance control: 20%

Luminance control frequency: 285Hz (typ.)

Note1: Luminance control frequency indicate the input pulse frequency, when select the external pulse control. See "4.6.2 Detail of PWM timing".

Note2: The power supply lines (VDDB and GNDB) have large ripple voltage (See "4.3.4 Power supply voltage ripple".) during luminance control. There is the possibility that the ripple voltage produces acoustic noise and signal wave noise in audio circuit and so on. Put a capacitor (5,000 to 6,000μF) between the power supply lines (VDDB and GNDB) to reduce the noise, if the noise occurred in the circuit.

4.3.4 Power supply voltage ripple

This product works, even if the ripple voltage levels are beyond the permissible values as following the table, but there might be noise on the display image.

Power supply voltage		Ripple voltage (Measure at input terminal of power supply)	Note1 Unit
VDD	12.0 V	≤ 100	mVp-p
VDDDB	12.0 V	≤ 200	mVp-p

Note1: The permissible ripple voltage includes spike noise.

Example of the power supply connection

a) Separate the power supply

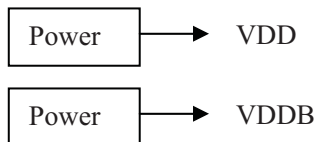

b) Put in the filter

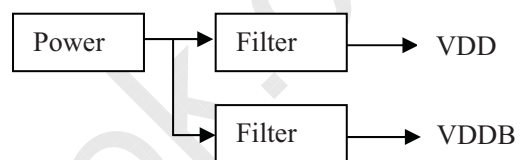

4.3.5 Fuse

Parameter	Fuse		Rating	Fusing current	Remarks
	Type	Supplier			
VDD	FHC20 502AD	KAMAYA ELECTRIC Co., Ltd.	5A	12.5A, 5s max.	Note1
			24V		
VDDDB	0453007	Littelfuse Inc.	7A	14A, 5s max.	
			125V		

Note1: The power supply capacity should be more than the fusing current. If it is less than the fusing current, the fuse may not blow in a short time, and then nasty smell, smoke and so on may occur.

☆

4.4 POWER SUPPLY VOLTAGE SEQUENCE

4.4.1 LCD panel signal processing board

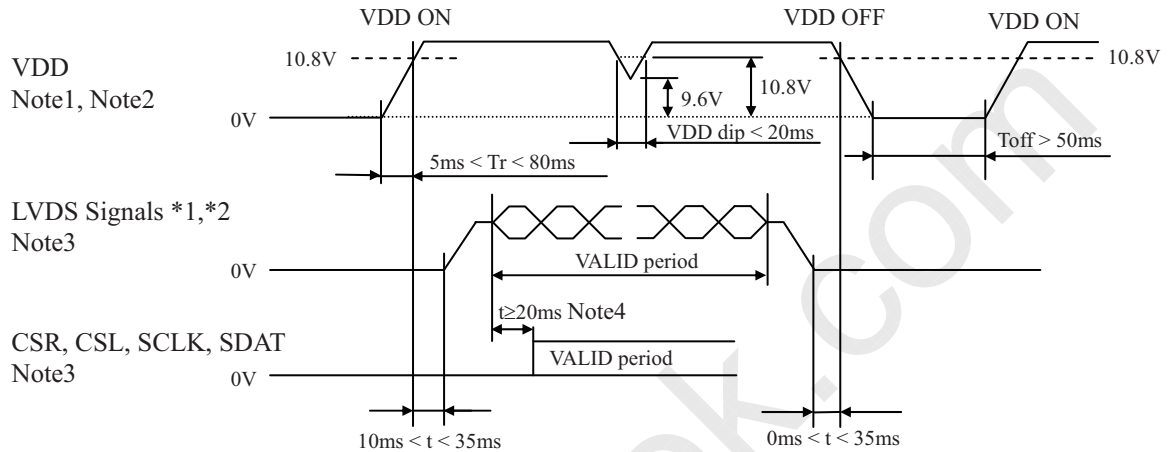

*1: DA0+/-, DA1+/-, DA2+/-, DA3+/-, CKA+/-, DB0+/-, DB1+/-, DB2+/-, DB3+/-, CKB+/-, DC0+/-, DC1+/-, DC2+/-, DC3+/-, CKC+/-, DD0+/-, DD1+/-, DD2+/-, DD3+/-, CKD+/-

*2: LVDS signals should be measured at the terminal of 100Ω resistance.

Note1: In terms of voltage variation (voltage drop) while VDD rising edge is below 10.8V, a protection circuit may work, and then this product may not work.

Note2: VDD should be 10.8V or more during VDD ON period.

Note3: LVDS signals and CSR, CSL, SCLK, SDAT must be Low or High-impedance, exclude the VALID period (See above sequence diagram), in order to avoid that internal circuits is damaged.

If some of signals are cut while this product is working, even if the signal input to it once again, it might not work normally. If customer stops the display and function signals, they should be cut VDD.

Note4: At the beginning of the serial communication mode, take 20ms or more after the LVDS signal input.

4.4.2 Inverter

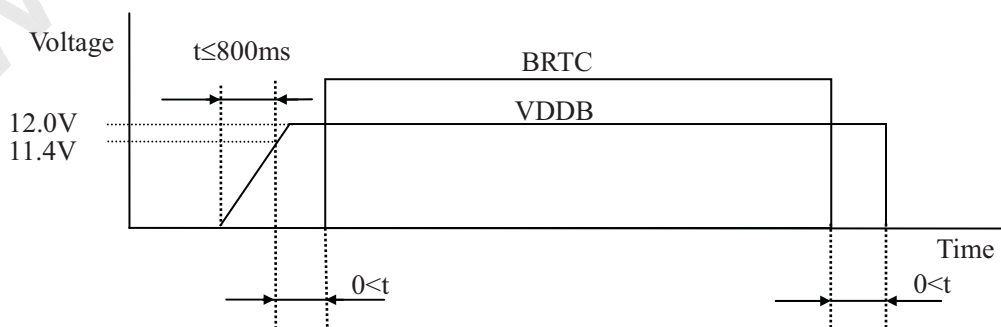

Note1: The inverter power supply voltage (VDDDB) should be inputted within the valid period of LVDS signals, in order to avoid unstable data display.

Note2: If tr is more than 800ms, the backlight will be turned off by a protection circuit for inverter.

Note3: When VDDDB is 0V or BRTC is Low, PWSEL must be set to Low or Open.

NEC NEC LCD Technologies, Ltd.

NL256204AM15-01/01A

4.5 CONNECTIONS AND FUNCTIONS FOR INTERFACE PINS

4.5.1 LCD panel signal processing board

CN1 socket (LCD module side): FI-W41P-HF (Japan Aviation Electronics Industry Limited (JAE))

Adaptable plug: FI-W41S (Japan Aviation Electronics Industry Limited (JAE))

Pin No.	Symbol	Signal	Remarks															
1	GND	Signal ground	Note1															
2	CSR	Chip selection R	LUT communication control signal See "4.13 TEN-bit LOOK UP TABLE FOR GAMMA ADJUSTMENT".															
3	CSL	Chip selection L																
4	SCLK	Serial Clock																
5	SDAT	Serial Data																
6	MOD0	Selection of LVDS Data Transmission Mode (Pull-up 25kΩ)	See "4.10 LVDS DATA TRANSMISSION MODE".															
7	MOD1		<table border="1"> <thead> <tr> <th>MOD0</th> <th>MOD1</th> <th>Mode</th> </tr> </thead> <tbody> <tr> <td>Open</td> <td>Open</td> <td>0</td> </tr> <tr> <td>Open</td> <td>Low</td> <td>1</td> </tr> <tr> <td>Low</td> <td>Open</td> <td>Reserved</td> </tr> <tr> <td>Low</td> <td>Low</td> <td>0</td> </tr> </tbody> </table>	MOD0	MOD1	Mode	Open	Open	0	Open	Low	1	Low	Open	Reserved	Low	Low	0
MOD0	MOD1		Mode															
Open	Open		0															
Open	Low	1																
Low	Open	Reserved																
Low	Low	0																
8	BSEL0	Selection of LVDS data input map (Pull-up 25kΩ)	See "4.7 METHOD OF CONNECTION FOR LVDS TRANSMITTER".															
9	BSEL1		<table border="1"> <thead> <tr> <th>BSEL0</th> <th>BSEL1</th> <th>Mode</th> </tr> </thead> <tbody> <tr> <td>Open</td> <td>Open</td> <td>A</td> </tr> <tr> <td>Open</td> <td>Low</td> <td>B</td> </tr> <tr> <td>Low</td> <td>Open</td> <td>C</td> </tr> <tr> <td>Low</td> <td>Low</td> <td>A</td> </tr> </tbody> </table>	BSEL0	BSEL1	Mode	Open	Open	A	Open	Low	B	Low	Open	C	Low	Low	A
BSEL0	BSEL1		Mode															
Open	Open		A															
Open	Low	B																
Low	Open	C																
Low	Low	A																
10	RSVD	Reserved	Keep this pin Open.															
11	GND	Signal ground	Note1															
12	DB3+	Pixel data B3	LVDS differential data input Note2															
13	DB3-																	
14	GND	Signal ground	Note1															
15	CKB+	Pixel clock B	LVDS differential clock input Note2															
16	CKB-																	
17	GND	Signal ground	Note1															
18	DB2+	Pixel data B2	LVDS differential data input Note2															
19	DB2-																	
20	GND	Signal ground	Note1															
21	DB1+	Pixel data B1	LVDS differential data input Note2															
22	DB1-																	
23	GND	Signal ground	Note1															
24	DB0+	Pixel data B0	LVDS differential data input Note2															
25	DB0-																	
26	GND	Signal ground	Note1															
27	DA3+	Pixel data A3	LVDS differential data input Note2															
28	DA3-																	
29	GND	Signal ground	Note1															
30	CKA+	Pixel clock A	LVDS differential clock input Note2															
31	CKA-																	
32	GND	Signal ground	Note1															
33	DA2+	Pixel data A2	LVDS differential data input Note2															
34	DA2-																	
35	GND	Signal ground	Note1															
36	DA1+	Pixel data A1	LVDS differential data input Note2															
37	DA1-																	
38	GND	Signal ground	Note1															
39	DA0+	Pixel data A0	LVDS differential data input Note2															
40	DA0-																	
41	GND	Signal ground	Note1															

NEC NEC LCD Technologies, Ltd.

NL256204AM15-01/01A

Note1: All GND terminals should be used without any non-connected lines.

Note2: Twist pair wires with 100Ω (Characteristic impedance) should be connected between LCD panel signal processing board and LVDS transmitter.

CN1: Figure of socket



CN2 socket (LCD module side): FI-W31P-HF (Japan Aviation Electronics Industry Limited (JAE))

Adaptable plug: FI-W31S (Japan Aviation Electronics Industry Limited (JAE))

Pin No.	Symbol	Signal	Remarks
1	GND	Signal ground	Note1
2	DD3+	Pixel data D3	LVDS differential data input Note2
3	DD3-		
4	GND	Signal ground	Note1
5	CKD+	Pixel clock D	LVDS differential clock input Note2
6	CKD-		
7	GND	Signal ground	Note1
8	DD2+	Pixel data D2	LVDS differential data input Note2
9	DD2-		
10	GND	Signal ground	Note1
11	DD1+	Pixel data D1	LVDS differential data input Note2
12	DD1-		
13	GND	Signal ground	Note1
14	DD0+	Pixel data D0	LVDS differential data input Note2
15	DD0-		
16	GND	Signal ground	Note1
17	DC3+	Pixel data C3	LVDS differential data input Note2
18	DC3-		
19	GND	Signal ground	Note1
20	CKC+	Pixel clock C	LVDS differential clock input Note2
21	CKC-		
22	GND	Signal ground	Note1
23	DC2+	Pixel data C2	LVDS differential data input Note2
24	DC2-		
25	GND	Signal ground	Note1
26	DC1+	Pixel data C1	LVDS differential data input Note2
27	DC1-		
28	GND	Signal ground	Note1
29	DC0+	Pixel data C0	LVDS differential data input Note2
30	DC0-		
31	GND	Signal ground	Note1

Note1: All GND terminals should be used without any non-connected lines.

Note2: Twist pair wires with 100Ω (Characteristic impedance) should be connected between LCD panel signal processing board and LVDS transmitter.

CN2: Figure of socket

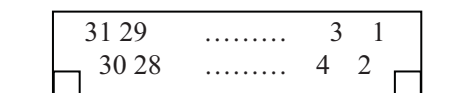

NEC NEC LCD Technologies, Ltd.**NL256204AM15-01/01A**

CN3 socket (LCD module side): IL-Z-8PL-SMTY (Japan Aviation Electronics Industry Limited (JAE))
Adaptable plug: IL-Z-8S-S125C (Japan Aviation Electronics Industry Limited (JAE))

Pin No.	Symbol	Function	Description
1	VDD	Power supply	Note1
2	VDD		
3	VDD		
4	VDD		
5	GND	Signal ground	Note1
6	GND		
7	GND		
8	GND		

Note1: All VDD and GND terminals should be used without any non-connected lines.

4.5.2 Inverter

CN201 socket (LCD module side): DF3Z-8P-2H (HIROSE ELECTRIC Co.,Ltd.) ☆

Adaptable plug: DF3-8S-2C (HIROSE ELECTRIC Co.,Ltd.) ☆

Pin No.	Symbol	Function	Description
1	GNDB	Inverter ground	Note1
2	GNDB		
3	GNDB		
4	GNDB		
5	VDDDB	Power supply	Note1
6	VDDDB		
7	VDDDB		
8	VDDDB		

Note1: All VDDDB and GNDB terminals should be used without any non-connected lines.

CN202 socket (LCD module side): IL-Z-9PL-SMTYE (Japan Aviation Electronics Industry Limited (JAE)) ☆

Adaptable plug: IL-Z-9S-S125C3 (Japan Aviation Electronics Industry Limited (JAE))

Pin No.	Symbol	Function	Description
1	GNDB	Inverter ground	Note1
2	GNDB		
3	N.C.	-	Keep this pin Open.
4	BRTC	Backlight ON/OFF control signal	High or Open: Backlight ON Low: Backlight OFF
5	BRTH	Luminance control terminal	See "4.6 LUMINANCE CONTROL".
6	BRTI		
7	BRTP		
8	GNDB	Inverter ground	Note1
9	PWSEL	Selection of luminance control signal method	See "4.6 LUMINANCE CONTROL". Note2

Note1: All GNDB terminals should be used without any non-connected lines.

Note2: When VDDDB is 0V or BRTC is Low, PWSEL must be set to Low or Open.

4.5.3 Positions of socket

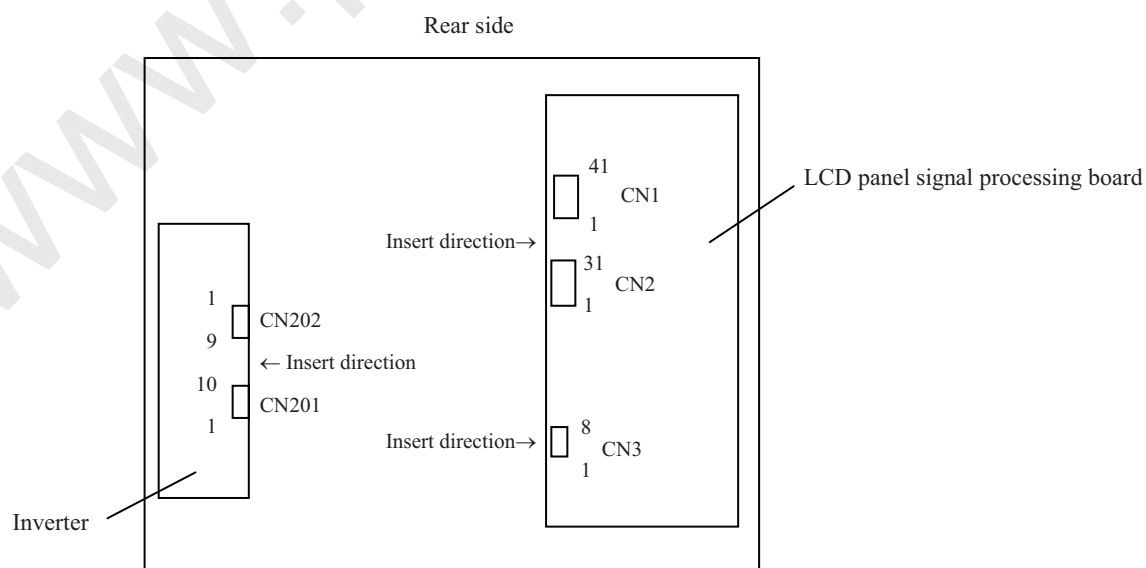

4.6 LUMINANCE CONTROL

4.6.1 Luminance control methods

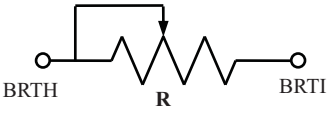
Method	Adjustment and luminance ratio	PWSEL terminal	BRTP terminal						
Variable resistor control Note1	<ul style="list-style-type: none"> Adjustment The variable resistor (R) for luminance control should be 10kΩ \pm5%, B curve, 1/10W. Minimum point of the resistance is the minimum luminance and maximum point of the resistance is the maximum luminance. The resistor (R) must be connected between BRTH-BRTI terminals.  <ul style="list-style-type: none"> Luminance ratio Note3 <table border="1"> <thead> <tr> <th>Resistance</th> <th>Luminance ratio</th> </tr> </thead> <tbody> <tr> <td>0 Ω</td> <td>30% (Min. Luminance)</td> </tr> <tr> <td>10 kΩ</td> <td>100% (Max. Luminance)</td> </tr> </tbody> </table>	Resistance	Luminance ratio	0 Ω	30% (Min. Luminance)	10 k Ω	100% (Max. Luminance)	High or Open	Open
Resistance	Luminance ratio								
0 Ω	30% (Min. Luminance)								
10 k Ω	100% (Max. Luminance)								
Voltage control Note1	<ul style="list-style-type: none"> Adjustment Voltage control method works, when BRTH terminal is 0V and VBI voltage is input between BRTI-BRTH terminals. This control method can carry out continuation adjustment of luminance. Luminance is the maximum when BRTI terminal is Open. <ul style="list-style-type: none"> Luminance ratio Note3 <table border="1"> <thead> <tr> <th>BRTI Voltage (VBI)</th> <th>Luminance ratio</th> </tr> </thead> <tbody> <tr> <td>0V</td> <td>30% (Min. Luminance)</td> </tr> <tr> <td>1.0V</td> <td>100% (Max. Luminance)</td> </tr> </tbody> </table>	BRTI Voltage (VBI)	Luminance ratio	0V	30% (Min. Luminance)	1.0V	100% (Max. Luminance)		
BRTI Voltage (VBI)	Luminance ratio								
0V	30% (Min. Luminance)								
1.0V	100% (Max. Luminance)								
Pulse width modulation Note1 Note2	<ul style="list-style-type: none"> Adjustment Pulse width modulation (PWM) method works, when PWSEL terminal is Low and PWM signal (BRTP signal) is input into BRTP terminal. The luminance is controlled by duty ratio of BRTP signal. <ul style="list-style-type: none"> Luminance ratio Note3 <table border="1"> <thead> <tr> <th>Duty ratio Note4</th> <th>Luminance ratio</th> </tr> </thead> <tbody> <tr> <td>0.2</td> <td>20% (Min. Luminance)</td> </tr> <tr> <td>1.0</td> <td>100% (Max. Luminance)</td> </tr> </tbody> </table>	Duty ratio Note4	Luminance ratio	0.2	20% (Min. Luminance)	1.0	100% (Max. Luminance)	Low	BRTP signal
Duty ratio Note4	Luminance ratio								
0.2	20% (Min. Luminance)								
1.0	100% (Max. Luminance)								

Note1: In case of the variable resistor control method and the voltage control method, noises may appear on the display image depending on the input signals timing for LCD panel signal processing board.

Use PWM method, if interference noises appear on the display image!

Note2: The inverter will stop working, when BRTP signal is fixed to Low while BRTP signal is High or Open. Then the backlight will not turn on anymore, even if BRTP signal is input again. This is not out of order. Backlight inverter will start to work when power is supplied again.

Note3: These data are the target values.

Note4: See "4.6.2 Detail of PWM timing".

4.6.2 Detail of B RTP timing

(1) Timing diagrams

• Outline chart

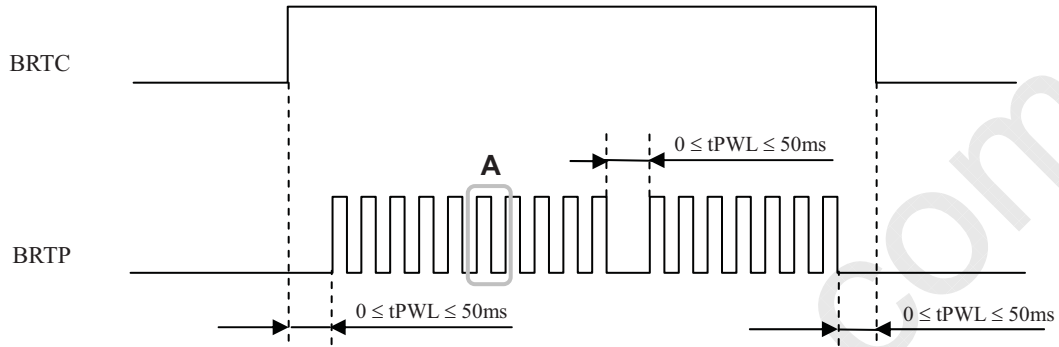

• Detail of A part

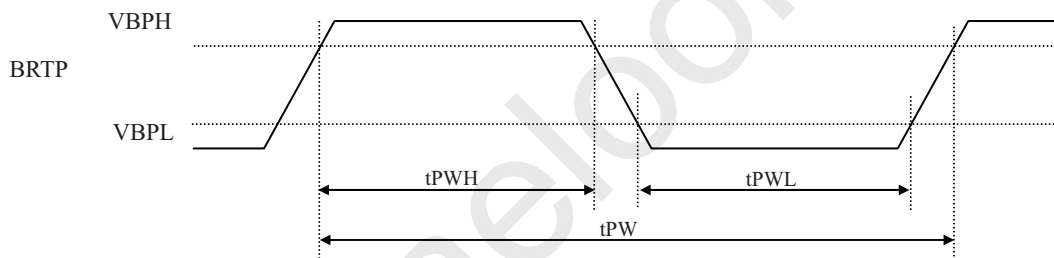

(2) Each parameter

Parameter	Symbol	min.	typ.	max.	Unit	Remarks
Luminance control frequency	FL	185	-	325	Hz	Note1, Note2
Duty ratio	DL	0.2	-	1.0	-	Note1, Note3
Low period	tPWL	0	-	50	ms	Note4

Note1: Definition of parameters is as follows.

$$FL = \frac{1}{tPW} \quad DL = \frac{tPWH}{tPW}$$

Note2: See the following formula for luminance control frequency.

$$\text{Luminance control frequency} = 1/tv \times (n+0.25) \text{ [or } (n + 0.75)]$$

$$n = 1, 2, 3 \dots \dots$$

tv: Vertical cycle (See "4.9.1 Timing characteristics".)

The interference noise of luminance control frequency and input signal frequency for LCD panel signal processing board may appear on a display. Set up luminance control frequency so that the interference noise does not appear!

Note3: See "4.6.1 Luminance control methods".

Note4: If tPWL is more than 50ms, the backlight will be turned off by a protection circuit for inverter.

4.7 METHOD OF CONNECTION FOR LVDS TRANSMITTER

LVDS data input map is selectable by BSEL0 and BSEL1 terminal.

	Bit mapping			Transmitter Pin Assignment			Output Connector	CN1		
	BSEL[1:0] Note1, Note2			Single type LVDS Tx	Dual type LVDS TX			Pin No.	Signal name	
	[H:H], [L:L] Mode A	[H:L] Mode B	[L:H] Mode C		THine THC63LVD823	NS DS90C387				
Pixel data A	LA2	LA7	LA0	TA0	R12	R10	ATA- ATA+	→ →	40 39	DA0- DA0+
	LA3	LA6	LA1	TA1	R13	R11				
	LA4	LA5	LA2	TA2	R14	R12				
	LA5	LA4	LA3	TA3	R15	R13				
	LA6	LA3	LA4	TA4	R16	R14				
	LA7	LA2	LA5	TA5	R17	R15				
	CA2	CA7	CA0	TA6	G12	G10	ATB- ATB+	→ →	37 36	DA1- DA1+
	CA3	CA6	CA1	TB0	G13	G11				
	CA4	CA5	CA2	TB1	G14	G12				
	CA5	CA4	CA3	TB2	G15	G13				
	CA6	CA3	CA4	TB3	G16	G14				
	CA7	CA2	CA5	TB4	G17	G15				
	RA2	RA7	RA0	TB5	B12	B10	ATC- ATC+	→ →	34 33	DA2- DA2+
	RA3	RA6	RA1	TB6	B13	B11				
	RA4	RA5	RA2	TC0	B14	B12				
	RA5	RA4	RA3	TC1	B15	B13				
	RA6	RA3	RA4	TC2	B16	B14				
	RA7	RA2	RA5	TC3	B17	B15				
	Hsync	Hsync	Hsync	TC4	HSYNC	HSYNC	ATD- ATD+	→ →	28 27	DA3- DA3+
	Vsync	Vsync	Vsync	TC5	VSYNC	VSYNC				
	DE	DE	DE	TC6	DE	DE				
	LA0	LA1	LA6	TD0	R10	R16				
	LA1	LA0	LA7	TD1	R11	R17				
	CA0	CA1	CA6	TD2	G10	G16				
CA1	CA0	CA7	TD3	G11	G17	ATCLK- ATCLK+	→ →	31 30	CKA- CKA+	
RA0	RA1	RA6	TD4	B10	B16					
RA1	RA0	RA7	TD5	B11	B17					
N.C.	N.C.	N.C.	TD6	-	-					
CLK	CLK	CLK	CLK	CLK	CLK					
CLK	CLK	CLK	CLK	CLK	CLK					
Pixel data B	LB2	LB7	LB0	TA0	R22	R20	BTA- BTA+	→ →	25 24	DB0- DB0+
	LB3	LB6	LB1	TA1	R23	R21				
	LB4	LB5	LB2	TA2	R24	R22				
	LB5	LB4	LB3	TA3	R25	R23				
	LB6	LB3	LB4	TA4	R26	R24				
	LB7	LB2	LB5	TA5	R27	R25				
	CB2	CB7	CB0	TA6	G22	G20	BTB- BTB+	→ →	22 21	DB1- DB1+
	CB3	CB6	CB1	TB0	G23	G21				
	CB4	CB5	CB2	TB1	G24	G22				
	CB5	CB4	CB3	TB2	G25	G23				
	CB6	CB3	CB4	TB3	G26	G24				
	CB7	CB2	CB5	TB4	G27	G25				
	RB2	RB7	RB0	TB5	B22	B20	BTC- BTC+	→ →	19 18	DB2- DB2+
	RB3	RB6	RB1	TB6	B23	B21				
	RB4	RB5	RB2	TC0	B24	B22				
	RB5	RB4	RB3	TC1	B25	B23				
	RB6	RB3	RB4	TC2	B26	B24				
	RB7	RB2	RB5	TC3	B27	B25				
	Hsync	Hsync	Hsync	TC4	HSYNC	HSYNC	BTD- BTD+	→ →	13 12	DB3- DB3+
	Vsync	Vsync	Vsync	TC5	VSYNC	VSYNC				
	DE	DE	DE	TC6	DE	DE				
	LB0	LB1	LB6	TD0	R20	R26				
	LB1	LB0	LB7	TD1	R21	R27				
	CB0	CB1	CB6	TD2	G20	G26				
CB1	CB0	CB7	TD3	G21	G27	BTCLK- BTCLK+	→ →	16 15	CKB- CKB+	
RB0	RB1	RB6	TD4	B20	B26					
RB1	RB0	RB7	TD5	B21	B27					
N.C.	N.C.	N.C.	TD6	-	-					
CLK	CLK	CLK	CLK	CLK	CLK					
CLK	CLK	CLK	CLK	CLK	CLK					

NEC LCD Technologies, Ltd.

NL256204AM15-01/01A

	BSEL[1:0] Note1, Note2			Single type LVDS Tx	Dual type LVDS TX		Output Connector	CN2					
	[H:H], [L:L] Mode A	[H:L] Mode B	[L:H] Mode C		THine THC63LVD823	NS DS90C387		Pin No.	Signal name				
Pixel data C	LC2	LC7	LC0	TA0	R12	R10	CTA- CTA+	→ →	30 29	DC0- DC0+			
	LC3	LC6	LC1	TA1	R13	R11							
	LC4	LC5	LC2	TA2	R14	R12							
	LC5	LC4	LC3	TA3	R15	R13							
	LC6	LC3	LC4	TA4	R16	R14							
	LC7	LC2	LC5	TA5	R17	R15							
	CC2	CC7	CC0	TA6	G12	G10	CTB- CTB+	→ →	27 26	DC1- DC1+			
	CC3	CC6	CC1	TB0	G13	G11							
	CC4	CC5	CC2	TB1	G14	G12							
	CC5	CC4	CC3	TB2	G15	G13							
	CC6	CC3	CC4	TB3	G16	G14							
	CC7	CC2	CC5	TB4	G17	G15							
	RC2	RC7	RC0	TB5	B12	B10	CTC- CTC+	→ →	24 23	DC2- DC2+			
	RC3	RC6	RC1	TB6	B13	B11							
	RC4	RC5	RC2	TC0	B14	B12							
	RC5	RC4	RC3	TC1	B15	B13							
	RC6	RC3	RC4	TC2	B16	B14							
	RC7	RC2	RC5	TC3	B17	B15							
	Hsync	Hsync	Hsync	TC4	HSYNC	HSYNC	CTD- CTD+	→ →	18 17	DC3- DC3+			
	Vsync	Vsync	Vsync	TC5	VSYNC	VSYNC							
	DE	DE	DE	TC6	DE	DE							
	LC0	LC1	LC6	TD0	R10	R16							
	LC1	LC0	LC7	TD1	R11	R17							
	CC0	CC1	CC6	TD2	G10	G16							
CC1	CC0	CC7	TD3	G11	G17	DTA- DTA+	→ →	15 14	DD0- DD0+				
RC0	RC1	RC6	TD4	B10	B16								
RC1	RC0	RC7	TD5	B11	B17								
N.C.	N.C.	N.C.	TD6	-	-								
CLK	CLK	CLK	CLK	CLK	CLK					DTB- DTB+	→ →	12 11	DD1- DD1+
LD2	LD7	LD0	TA0	R22	R20								
LD3	LD6	LD1	TA1	R23	R21	DTC- DTC+	→ →	9 8	DD2- DD2+				
LD4	LD5	LD2	TA2	R24	R22								
LD5	LD4	LD3	TA3	R25	R23								
LD6	LD3	LD4	TA4	R26	R24								
LD7	LD2	LD5	TA5	R27	R25								
CD2	CD7	CD0	TA6	G22	G20								
CD3	CD6	CD1	TB0	G23	G21	DTD- DTD+	→ →	3 2	DD3- DD3+				
CD4	CD5	CD2	TB1	G24	G22								
CD5	CD4	CD3	TB2	G25	G23								
CD6	CD3	CD4	TB3	G26	G24								
CD7	CD2	CD5	TB4	G27	G25								
RD2	RD7	RD0	TB5	B22	B20								
RD3	RD6	RD1	TB6	B23	B21	DTCLK- DTCLK+	→ →	6 5	CKD- CKD+				
RD4	RD5	RD2	TC0	B24	B22								
RD5	RD4	RD3	TC1	B25	B23								
RD6	RD3	RD4	TC2	B26	B24								
RD7	RD2	RD5	TC3	B27	B25								
Hsync	Hsync	Hsync	TC4	HSYNC	HSYNC								
Vsync	Vsync	Vsync	TC5	VSYNC	VSYNC								
DE	DE	DE	TC6	DE	DE								
LD0	LD1	LD6	TD0	R20	R26	DTCLK- DTCLK+	→ →	6 5	CKD- CKD+				
LD1	LD0	LD7	TD1	R21	R27								
CD0	CD1	CD6	TD2	G20	G26								
CD1	CD0	CD7	TD3	G21	G27								
RD0	RD1	RD6	TD4	B20	B26								
RD1	RD0	RD7	TD5	B21	B27								
N.C.	N.C.	N.C.	TD6	-	-								
CLK	CLK	CLK	CLK	CLK	CLK								

Note1: High must be Open.

Note2: Do not change the setting of BSEL0 and BSEL1 during VDD ON period.

Note3: Twist pair wires with 100Ω (Characteristic impedance) should be connected between LCD panel signal processing board and LVDS transmitter.

4.8 DISPLAY GRAY SCALE AND INPUT DATA SIGNALS

This product can display 256 gray scales in each LCR sub-pixel and 766 gray scales per 1 pixel. Also the relation between display gray scale and input data signals is as the following table.

Display gray scale		Data signal (0: Low level, 1: High level)																							
		LA7 LA6 LA5 LA4 LA3 LA2 LA1 LA0	CA7 CA6 CA5 CA4 CA3 CA2 CA1 CA0	RA7 RA6 RA5 RA4 RA3 RA2 RA1 RA0																					
		LB7 LB6 LB5 LB4 LB3 LB2 LB1 LB0	CB7 CB6 CB5 CB4 CB3 CB2 CB1 CB0	RB7 RB6 RB5 RB4 RB3 RB2 RB1 RB0																					
		LC7 LC6 LC5 LC4 LC3 LC2 LC1 LC0	CC7 CC6 CC5 CC4 CC3 CC2 CC1 CC0	RC7 RC6 RC5 RC4 RC3 RC2 RC1 RC0																					
		LD7 LD6 LD5 LD4 LD3 LD2 LD1 LD0	CD7 CD6 CD5 CD4 CD3 CD2 CD1 CD0	RD7 RD6 RD5 RD4 RD3 RD2 RD1 RD0																					
Left sub-pixel gray scale	Black	0 0 0 0 0 0 0 0	0 0 0 0 0 0 0 0	0 0 0 0 0 0 0 0																					
	dark	0 0 0 0 0 0 0 1	0 0 0 0 0 0 0 0	0 0 0 0 0 0 0 0																					
	↑	0 0 0 0 0 0 1 0	0 0 0 0 0 0 0 0	0 0 0 0 0 0 0 0																					
	↓	⋮	⋮	⋮																					
	bright	1 1 1 1 1 1 0 1	0 0 0 0 0 0 0 0	0 0 0 0 0 0 0 0																					
	White	1 1 1 1 1 1 1 1	0 0 0 0 0 0 0 0	0 0 0 0 0 0 0 0																					
Center sub-pixel gray scale	Black	0 0 0 0 0 0 0 0	0 0 0 0 0 0 0 0	0 0 0 0 0 0 0 0																					
	dark	0 0 0 0 0 0 0 0	0 0 0 0 0 0 0 1	0 0 0 0 0 0 0 0																					
	↑	0 0 0 0 0 0 0 0	0 0 0 0 0 0 1 0	0 0 0 0 0 0 0 0																					
	↓	⋮	⋮	⋮																					
	bright	0 0 0 0 0 0 0 0	1 1 1 1 1 1 0 1	0 0 0 0 0 0 0 0																					
	White	0 0 0 0 0 0 0 0	1 1 1 1 1 1 1 1	0 0 0 0 0 0 0 0																					
Right sub-pixel gray scale	Black	0 0 0 0 0 0 0 0	0 0 0 0 0 0 0 0	0 0 0 0 0 0 0 0																					
	dark	0 0 0 0 0 0 0 0	0 0 0 0 0 0 0 0	0 0 0 0 0 0 0 1																					
	↑	0 0 0 0 0 0 0 0	0 0 0 0 0 0 0 0	0 0 0 0 0 0 1 0																					
	↓	⋮	⋮	⋮																					
	bright	0 0 0 0 0 0 0 0	0 0 0 0 0 0 0 0	1 1 1 1 1 1 0 1																					
	White	0 0 0 0 0 0 0 0	0 0 0 0 0 0 0 0	1 1 1 1 1 1 1 1																					

4.9 INPUT SIGNAL TIMINGS

4.9.1 Timing characteristics

Parameter		Symbol	min.	typ.	max.	Unit	Remarks	
CLK	Frequency	1/tc	80.0	83.26	85.0	MHz	12.01 ns (typ.)	
	Duty	-	-			-	Note2	
	Rise time, Fall time	-	-			ns	Note2	
DATA	CLK-DATA	Setup time	-			ns	Note2	
		Hold time	-			ns		
	Rise time, Fall time	-	-			ns		
DE	Horizontal	Cycle	th	7.72	8.071	-	123.9 kHz (typ.) Note1, Note3	
		Display period	thd	660	672	690		CLK
	Vertical (One frame)	Cycle	tv	-	16.667	-	60.0 Hz (typ.) Note1	
		Display period	tvd	2,053	2,064	-		H
	CLK-DE	Setup time	-	-			ns	Note2
		Hold time	-	-			ns	
		Rise time, Fall time	-	-			ns	

Note1: Definition of parameters is as follows.

$$t_c = 1\text{CLK}, t_h = 1\text{H}$$

Note2: See the data sheet of LVDS transmitter.

Note3: "th" (CLK number) should be fixed to "16n+k" (n= natural number: 1,2,3..., k=0, 2, 4 or 6).

In case "th" is not the specified value, it may cause display deterioration.

e.g.: "th" (CLK number)= 660, 662, 672, 674, 676, 678, 688, 690

4.9.2 Input signal timing chart

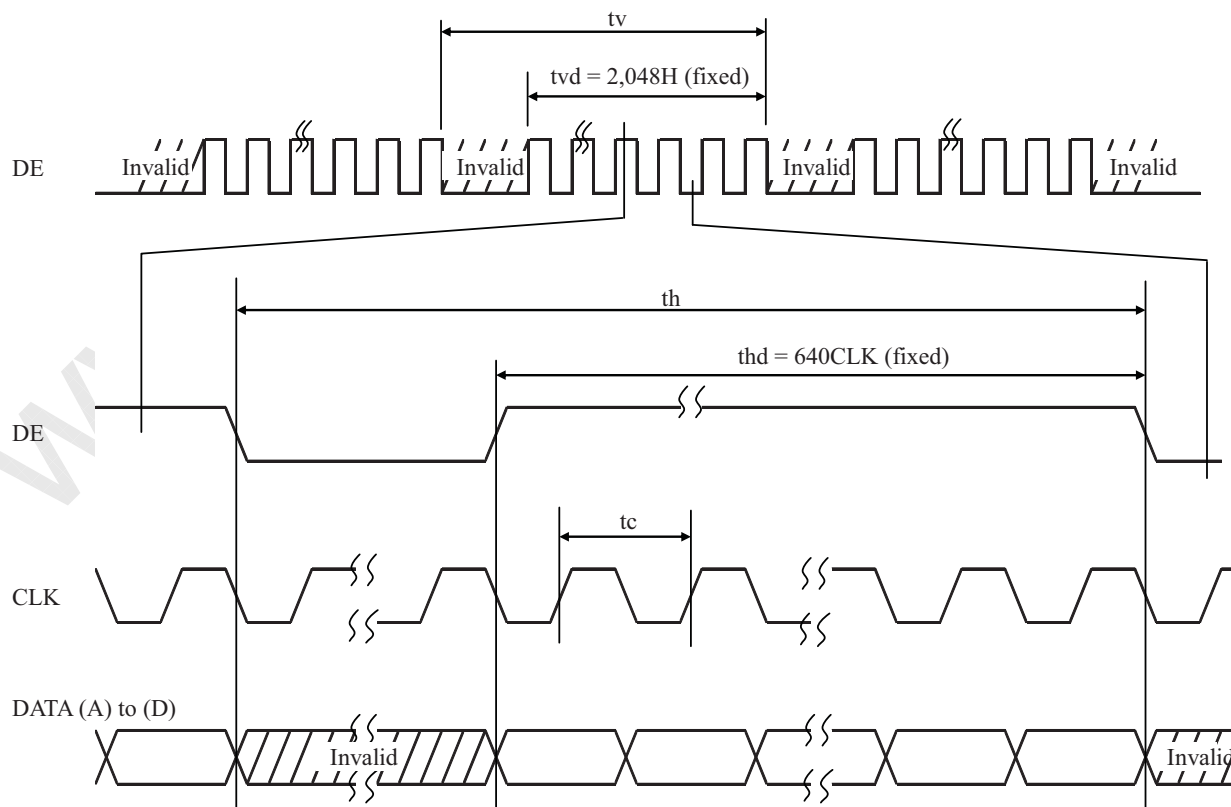

4.10 LVDS DATA TRANSMISSION MODE

Transmission mode of LVDS data is selectable by MOD0 and MOD1 terminal.

MOD[1:0] Notel		Mode name	Data transmission chart
1	0		
Open	Open	Mode 0 L/R transmission mode	
Low	Low		
Open	Low	Mode 1 4 divided transmission mode	
Low	Open	Reserved	-

Note1: High must be Open.

4.11 DISPLAY POSITIONS

(1) Mode0: MOD0= Open, MOD1= Open / MOD0= Low, MOD1= Low

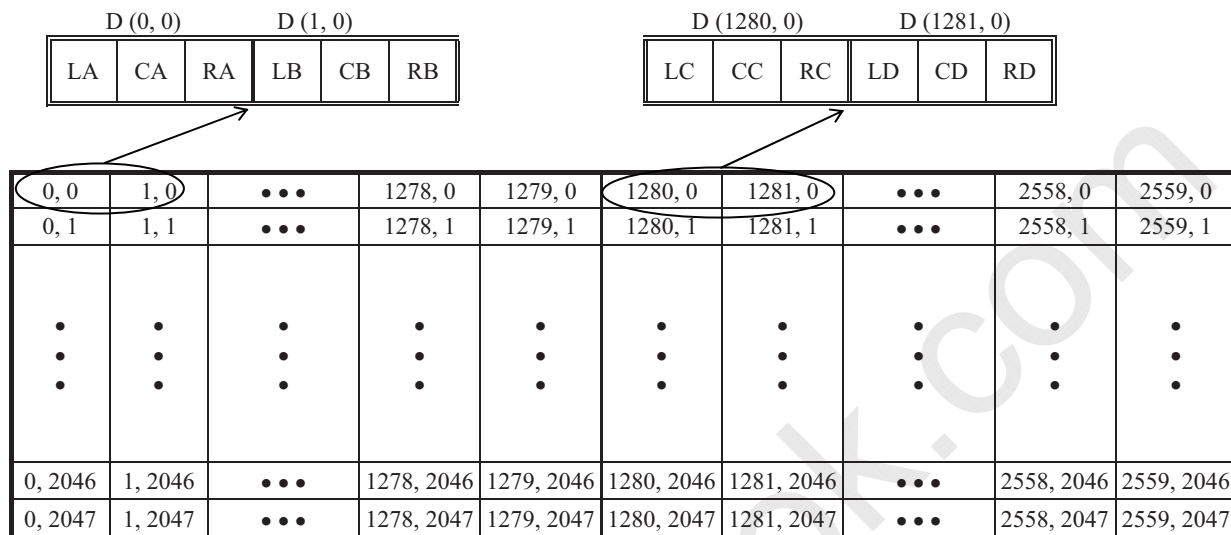

(2) Model: MOD0= Open, MOD1= Low

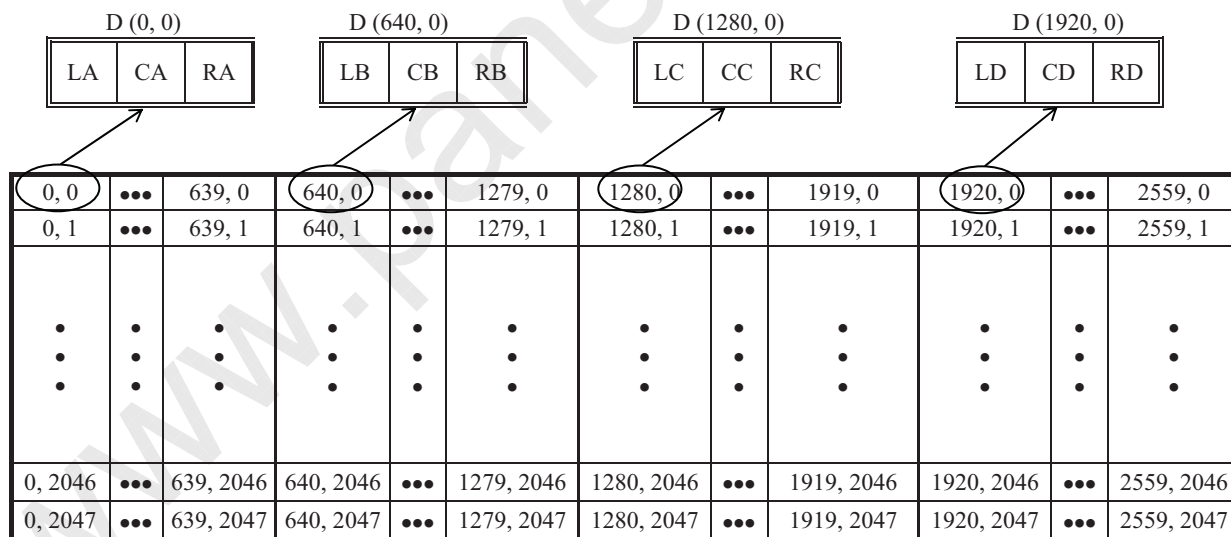

4.12 PIXEL ARRANGMENT

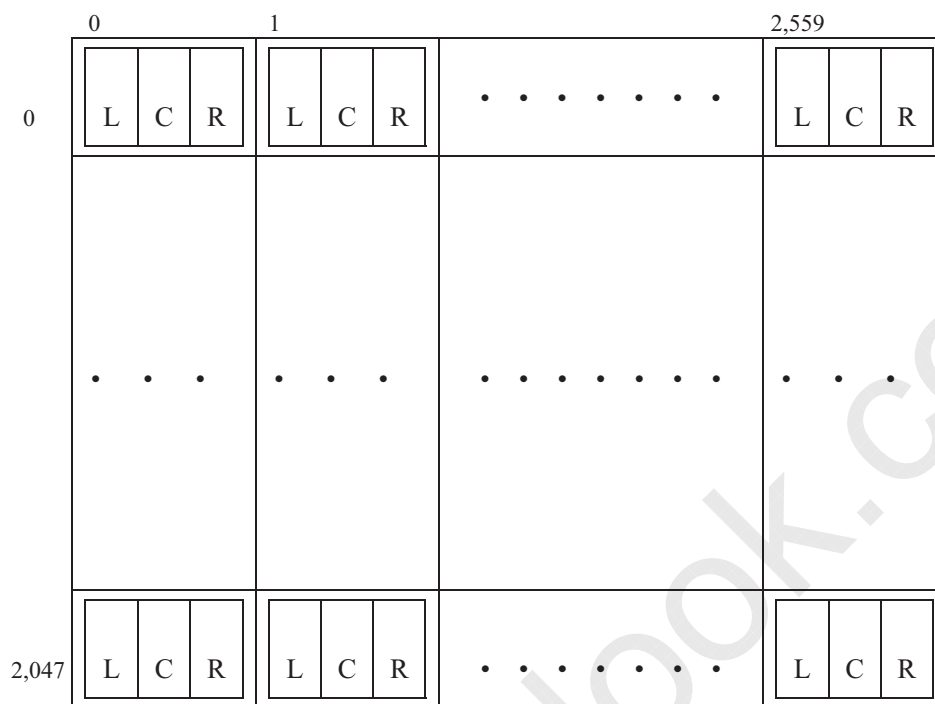

4.13 TEN-bit LOOK UP TABLE FOR GAMMA ADJUSTMENT

Adjustment of gamma characteristics for each 8-bit LCR data is possible by using built-in 10-bit LUT (look up table) for Gamma characteristics.

The LUT is set with the serial data. The combination of the control command determines Random/Sequential Address WRITE and Individual/Simultaneous LCR setting.

The serial data is composed as Table1.

Table1: Serial data Composition

DATA	DATA name	Function	Remarks
D31	CMD5	Control Command	See Table2 and 3.
D30	CMD4	Control Command	
D29	CMD3	Control Command	
D28	CMD2	Control Command	
D27	CMD1	Control Command	
D26	CMD0	Control Command	
D25	ADD9	LUT Address (MSB)	See Table4.
D24	ADD8	LUT Address	
D23	ADD7	LUT Address	
D22	ADD6	LUT Address	
D21	ADD5	LUT Address	
D20	ADD4	LUT Address	
D19	ADD3	LUT Address	
D18	ADD2	LUT Address	
D17	ADD1	LUT Address	
D16	ADD0	LUT Address (LSB)	See Table5.
D15	DATA15	LUT Data (MSB)	
D14	DATA14	LUT Data	
D13	DATA13	LUT Data	
D12	DATA12	LUT Data	
D11	DATA11	LUT Data	
D10	DATA10	LUT Data	
D9	DATA9	LUT Data	
D8	DATA8	LUT Data	
D7	DATA7	LUT Data	
D6	DATA6	LUT Data	
D5	DATA5	LUT Data	
D4	DATA4	LUT Data	
D3	DATA3	LUT Data	
D2	DATA2	LUT Data	
D1	DATA1	LUT Data	
D0	DATA0	LUT Data (LSB)	

Table2: Command table (CMD5 to CMD0: 6-bit)

DATA name	Parameter	Remarks
CMD5	Must be set to "1".	-
CMD4	Must be set to "1".	-
CMD3	Selection of Random/Sequential Address WRITE "1": Random Address WRITE "0": Sequential Address WRITE	-
CMD2	Must be set to "1".	-
CMD1	Selection of Individual/Simultaneous LCR setting "1": Individual LCR setting "0": Simultaneous LCR setting	"1": Select the Sub-pixel by using ADD9 and ADD8. (See Table4.) "0": ADD9 and ADD8 are invalid.
CMD0	Must be set to "0".	-

Table3: Command table (CMD5 to CMD0: 6-bit)

CMD5	CMD4	CMD3	CMD2	CMD1	CMD0	Function
1	1	1	1	1	0	Random Address WRITE, Individual LCR setting
1	1	1	1	0	0	Random Address WRITE, Simultaneous LCR setting
1	1	0	1	1	0	Sequential Address WRITE, Individual LCR setting
1	1	0	1	0	0	Sequential Address WRITE, Simultaneous LCR setting

*Another combinations are prohibited, and may cause function error.

Table4: Address table (ADD9 to ADD0: 10-bit)

DATA name	Parameter	Remarks
ADD9	Sub-pixel Selection ADD[9:8]= 0:0 Left Sub-pixel	When "ADD[9:8]=1:1", ON/OFF of Gamma correction can select according to the GMA[2:0]. (See Table6 and Table7.)
ADD8	0:1 Center Sub-pixel	
	1:0 Right Sub-pixel	
	1:1 ON/OFF selection of Gamma Correction	
ADD7	LUT Address 256 address = 00h - FFh	When "ADD[9:8] = 1:1", ADD[7:0] must be set to 00h.
ADD6		
ADD5		
ADD4		
ADD3		
ADD2		
ADD1		
ADD0		

Table5: Data table (DATA15 to DATA0: 16-bit)

DATA	DATA name	Parameter	Remarks
DATA15	Dummy	Dummy Data Must be set to "0".	-
DATA14	Dummy		
DATA13	Dummy		
DATA12	Dummy		
DATA11	Dummy		
DATA10	Dummy		
DATA9	DATA9	[MSB]	-
DATA8	DATA8	10-bit LUT Data 000h - 3FFh	
DATA7	DATA7		
DATA6	DATA6		
DATA5	DATA5		
DATA4	DATA4		
DATA3	DATA3		
DATA2	DATA2		
DATA1	DATA1		
DATA0	DATA0	[LSB]	

Table6: Gamma correction table (DATA15 to DATA0: 16-bit)

DATA	DATA name	Parameter	Remarks
DATA15	Dummy	Dummy Data Must be set to "0".	-
DATA14	Dummy		
DATA13	Dummy		
DATA12	Dummy		
DATA11	Dummy		
DATA10	Dummy		
DATA9	Dummy		
DATA8	Dummy		
DATA7	Dummy		
DATA6	Dummy		
DATA5	Dummy		
DATA4	Dummy		
DATA3	Dummy		
DATA2	GAM2	[MSB]	See Table7.
DATA1	GAM1	GMA Data	
DATA0	GAM0	[LSB]	

Table7: Control code GAM[2:0]

GMA2	GMA1	GMA0	Function
0	0	0	No correction (Initial setting)
0	0	1	Correction according to the LUT Data. Note1

*Another combinations are prohibited, and may cause function error.

Note1: Initial setting of the LUT is undefined data. The LUT should be enabled by setting of the GMA after writing the LUT data in all the 256 addresses, in order to avoid undefined data display. ☆

Note2: Transfer the data every power-on, because the LUT data isn't stored in the LCD module.

Note3: When writing and reading the LUT data, a noise may appear on the display image. In order to prevent the noise appearing on the display, following measures should be performed.

(1)The LUT data should be rewritten during invalid period of pixel data (See "4.8 INPUT SIGNAL TIMINGS").

(2)The LUT data should be rewritten while the LUT data is invalid.

4.14 LUT SERIAL COMMUNICATION TIMINGS

(1) Timing chart

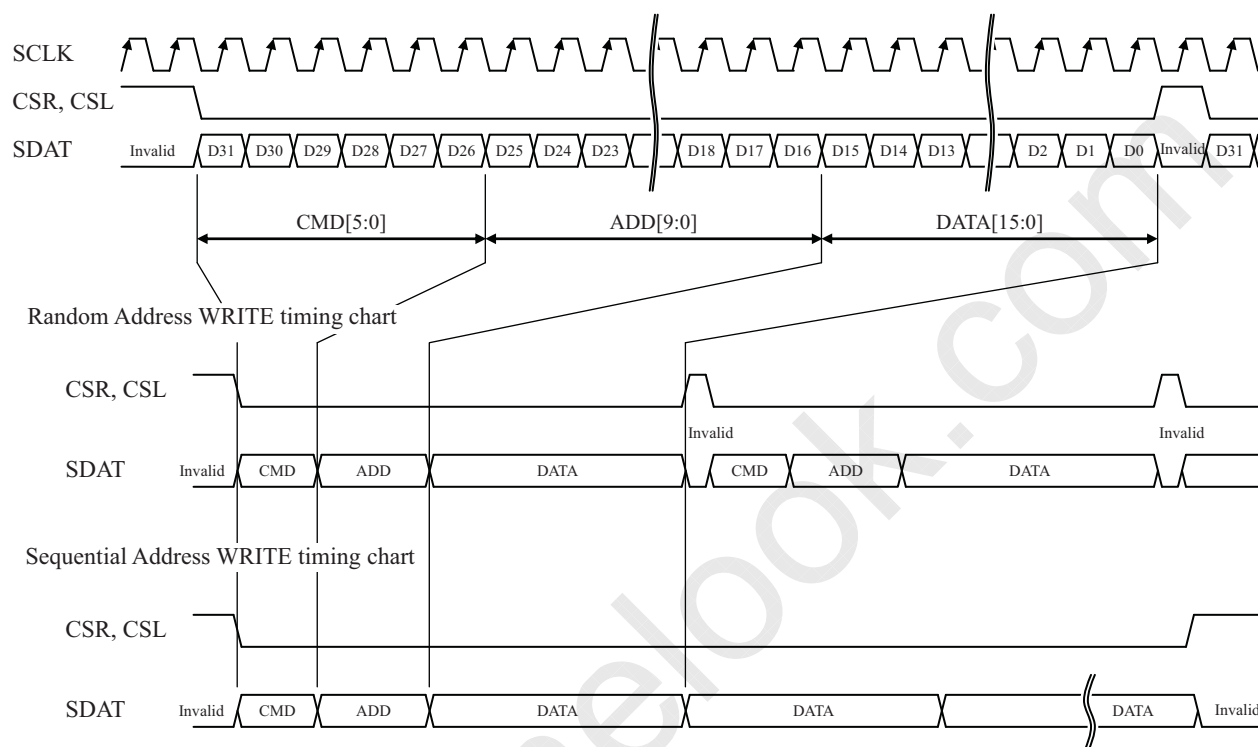

(2) Timing specifications

Parameter	Symbol	min.	typ.	max.	Unit	Remarks
SCLK Frequency	1/Tsck	-	-	5	MHz	-
SCLK Pulse	Twsck	50	-	-	ns	-
SDAT-SCLK Setup Time	Tds	50	-	-	ns	-
SDAT-SCLK Hold Time	Tdh	50	-	-	ns	-
CSR/CSL-SCLK Setup Time	Tcs	50	-	-	ns	-
CSR/CSL-SCLK Hold Time	Tch	50	-	-	ns	-

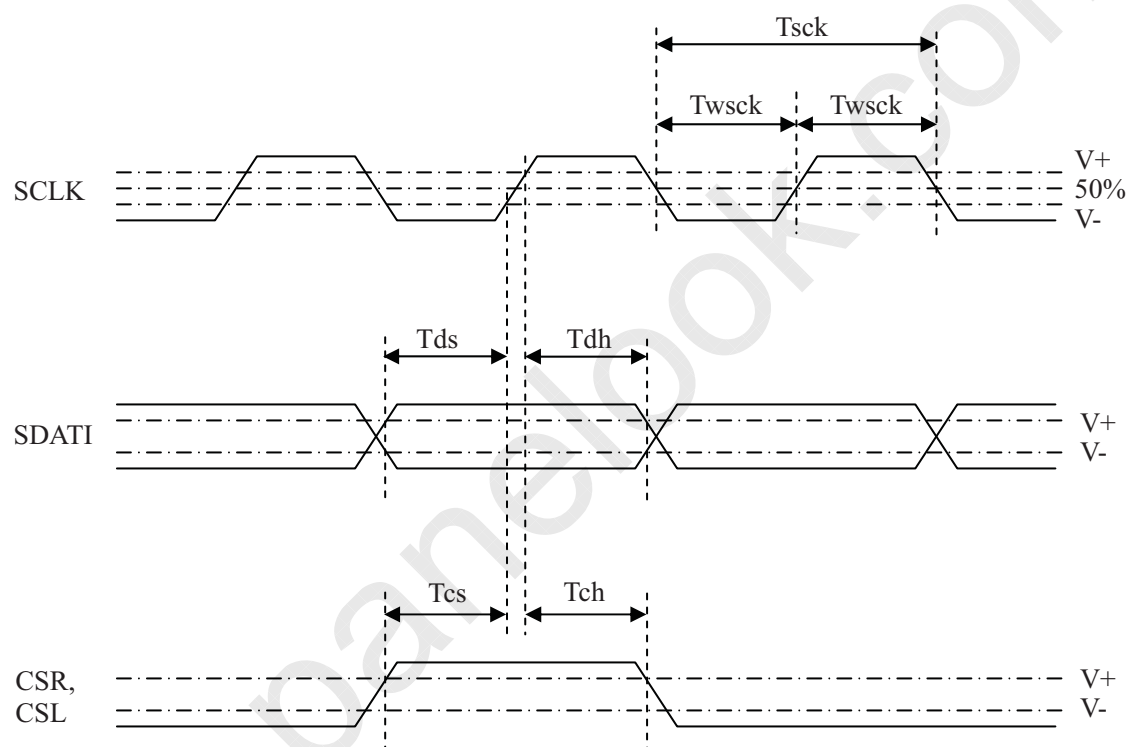

Note1: During the serial communication mode, the display noise may appear because of rewriting the data. To avoid this, rewrite the data in the blanking timing. The external noise may cause the data change, refresh the data regularly according to need.

4.15 OPTICS

4.15.1 Optical characteristics

(1) NL256204AM15-01

(Note1, Note2)

Parameter	Condition	Symbol	min.	typ.	max.	Unit	Measuring instrument	Remarks	
Luminance	White at center $\theta R = 0^\circ, \theta L = 0^\circ, \theta U = 0^\circ, \theta D = 0^\circ$	L	650	850	-	cd/m ²	BM-5A or SR-3	-	
Contrast ratio	White/Black at center $\theta R = 0^\circ, \theta L = 0^\circ, \theta U = 0^\circ, \theta D = 0^\circ$	CR	400	600	-	-	BM-5A or SR-3	Note3	
Luminance uniformity	White $\theta R = 0^\circ, \theta L = 0^\circ, \theta U = 0^\circ, \theta D = 0^\circ$	LU	-	1.1	1.3	-	BM-5A	Note4	
Chromaticity	White	x coordinate	Wx	-	0.255	-	-	SR-3	Note5
		y coordinate	Wy	-	0.310	-	-		
Response time		Black to White	Ton	-	15	25	ms	BM-5A	Note6 Note7
		White to Black	Toff	-	15	25	ms		
Viewing angle	Right	$\theta U = 0^\circ, \theta D = 0^\circ, CR \geq 10$	θR	70	85	-	°	BM-5A	Note8
	Left	$\theta U = 0^\circ, \theta D = 0^\circ, CR \geq 10$	θL	70	85	-	°		
	Up	$\theta R = 0^\circ, \theta L = 0^\circ, CR \geq 10$	θU	70	85	-	°		
	Down	$\theta R = 0^\circ, \theta L = 0^\circ, CR \geq 10$	θD	70	85	-	°		

(2) NL256204AM15-01A

(Note1, Note2)

Parameter	Condition	Symbol	min.	typ.	max.	Unit	Measuring instrument	Remarks	
Luminance	White at center $\theta R = 0^\circ, \theta L = 0^\circ, \theta U = 0^\circ, \theta D = 0^\circ$	L	650	850	-	cd/m ²	BM-5A or SR-3	-	
Contrast ratio	White/Black at center $\theta R = 0^\circ, \theta L = 0^\circ, \theta U = 0^\circ, \theta D = 0^\circ$	CR	400	600	-	-	BM-5A or SR-3	Note3	
Luminance uniformity	White $\theta R = 0^\circ, \theta L = 0^\circ, \theta U = 0^\circ, \theta D = 0^\circ$	LU	-	1.1	1.3	-	BM-5A	Note4	
Chromaticity	White	x coordinate	Wx	-	0.280	-	-	SR-3	Note5
		y coordinate	Wy	-	0.304	-	-		
Response time		Black to White	Ton	-	15	25	ms	BM-5A	Note6 Note7
		White to Black	Toff	-	15	25	ms		
Viewing angle	Right	$\theta U = 0^\circ, \theta D = 0^\circ, CR \geq 10$	θR	70	85	-	°	BM-5A	Note8
	Left	$\theta U = 0^\circ, \theta D = 0^\circ, CR \geq 10$	θL	70	85	-	°		
	Up	$\theta R = 0^\circ, \theta L = 0^\circ, CR \geq 10$	θU	70	85	-	°		
	Down	$\theta R = 0^\circ, \theta L = 0^\circ, CR \geq 10$	θD	70	85	-	°		

Note1: These are initial characteristics.

Note2: Measurement conditions are as follows.

Ta=25°C, VDD=12V, VDDB=12V, Luminance control = maximum, Display mode: QSXGA,
Horizontal cycle=1/123.9 kHz, Vertical cycle = 1/60.0 Hz

Optical characteristics are measured after 20minutes from working the product, in the dark room. Also measurement method for luminance is as follows.

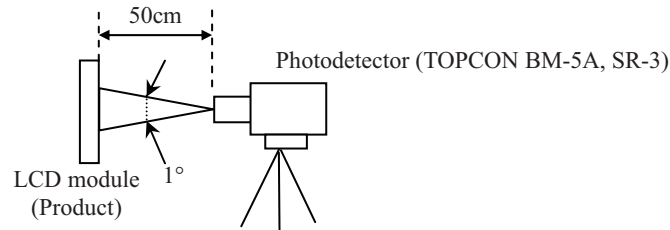

Note3: See "**4.15.2 Definition of contrast ratio**".

Note4: See "**4.15.3 Definition of luminance uniformity**".

Note5: These coordinates are found on CIE 1931 chromaticity diagram.

Note6: Product surface temperature: TopF=36°C

Note7: See "**4.15.4 Definition of response times**".

Note8: See "**4.15.5 Definition of viewing angles**".

4.15.2 Definition of contrast ratio

The contrast ratio is calculated by using the following formula.

$$\text{Contrast ratio (CR)} = \frac{\text{Luminance of white screen}}{\text{Luminance of black screen}}$$

4.15.3 Definition of luminance uniformity

The luminance uniformity is calculated by using following formula.

$$\text{Luminance uniformity (LU)} = \frac{\text{Maximum luminance from ① to ⑤}}{\text{Minimum luminance from ① to ⑤}}$$

The luminance is measured at near the 5 points shown below.

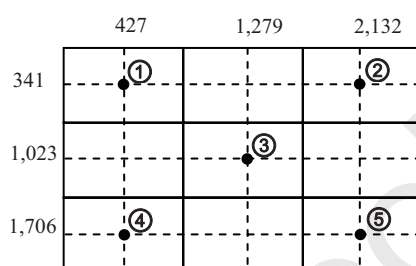

4.15.4 Definition of response times

Response time is measured, the luminance changes from "black" to "white", or "white" to "black" on the same screen point, by photo-detector. Ton is the time it takes the luminance change from 10% up to 90%. Also Toff is the time it takes the luminance change from 90% down to 10% (See the following diagram.).

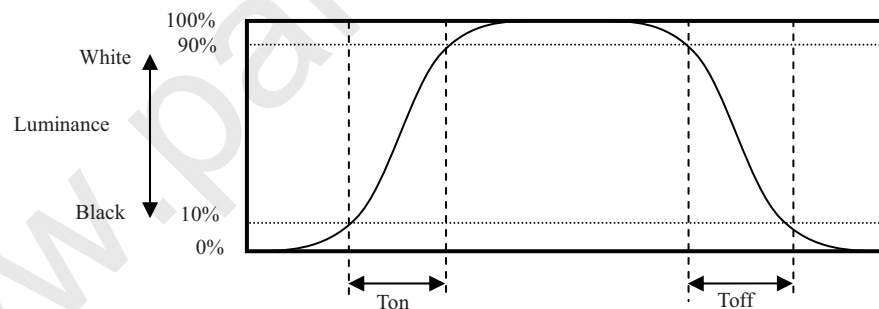

4.15.5 Definition of viewing angles

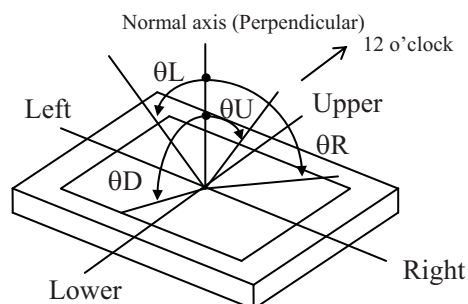

5. RELIABILITY TESTS

Test item	Condition	Judgment Note1
High temperature and humidity (Operation)	① $60 \pm 2^{\circ}\text{C}$, RH = 60%, 240hours ② Display data is white.	No display malfunctions
Heat cycle (Operation)	① $0 \pm 3^{\circ}\text{C}$...1hour $55 \pm 3^{\circ}\text{C}$...1hour ② 50cycles, 4hours/cycle ③ Display data is white.	
Thermal shock (Non operation)	① $-20 \pm 3^{\circ}\text{C}$...30minutes $60 \pm 3^{\circ}\text{C}$...30minutes ② 100cycles, 1hour/cycle ③ Temperature transition time is within 5 minutes.	
Vibration (Non operation)	① 5 to 100Hz, 11.76m/s^2 ② 1 minute/cycle ③ X, Y, Z direction ④ 10 times each directions	No display malfunctions No physical damages
Mechanical shock (Non operation)	① 294m/s^2 , 11ms ② X, Y, Z direction ③ 3 times each directions	No display malfunctions
ESD (Operation)	① 150pF, 150Ω , $\pm 10\text{kV}$ ② 9 places on a panel surface Note2 ③ 10 times each places at 1 sec interval	
Dust (Operation)	① Sample dust: No.15 (by JIS-Z8901) ② 15 seconds stir ③ 8 times repeat at 1 hour interval	No display malfunctions
Low pressure	Non-operation	
	Operation	① 53.3 kPa (Equivalent to altitude 4,850m) ② $0^{\circ}\text{C} \pm 3^{\circ}\text{C}$...24 hours ③ $+55^{\circ}\text{C} \pm 3^{\circ}\text{C}$...24 hours

Note1: Display and appearance are checked under environmental conditions equivalent to the inspection conditions of defect criteria.

Note2: See the following figure for discharge points

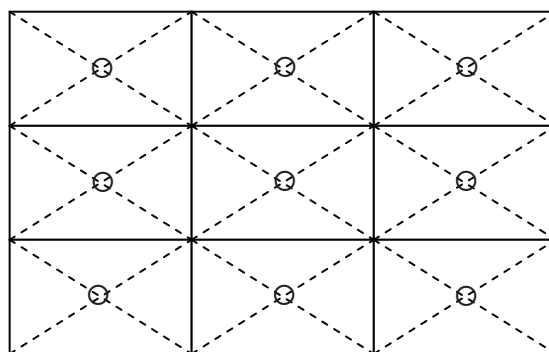

6. PRECAUTIONS

6.1 MEANING OF CAUTION SIGNS

The following caution signs have very important meaning. **Be sure to read "6.2 CAUTIONS" and "6.3 ATTENTIONS", after understanding these contents!**



This sign has the meaning that customer will be injured by himself or the product will sustain a damage, if customer has wrong operations.



This sign has the meaning that customer will get an electrical shock, if customer has wrong operations.



This sign has the meaning that customer will be injured by himself, if customer has wrong operations.

6.2 CAUTIONS



*** Do not touch the working backlight. Customer will be in danger of an electric shock.**



*** Do not touch the working backlight. Customer will be in danger of burn injury.
* Do not shock and press the LCD panel and the backlight! There is a danger of breaking, because they are made of glass. (Shock: To be not greater 294m/s^2 and to be not greater 11ms, Pressure: To be not greater 19.6N)**

6.3 ATTENTIONS



6.3.1 Handling of the product

- ① Take hold of both ends without touch the circuit board when customer pulls out products (LCD modules) from inner packing box. If customer touches it, products may be broken down or out of adjustment, because of stress to mounting parts.
- ② Do not hook nor pull cables such as lamp cable, and so on, in order to avoid damage.
- ③ If customer puts down the product temporarily, the product puts on flat subsoil as a display side turns down.
- ④ Take the measures of electrostatic discharge with such as earth band, ionic shower and so on, because products may be damaged by electrostatic when customer handles the product.
- ⑤ The torque for product mounting screws must never exceed 0.45 N·m. Higher torque values might result in distortion of the bezel.

- ⑥ The product must be installed using mounting holes without undue stress such as bends or twist (See outline drawings). And do not add undue stress to any portion (such as bezel flat area) except mounting hole portion.

Bends or twist described above and undue stress to any portion except mounting hole portion may cause display un-uniformity.

Recommendation installing method: An ideal plane that is defined by datum point and mounting holes is to be flush within ± 0.3 mm.

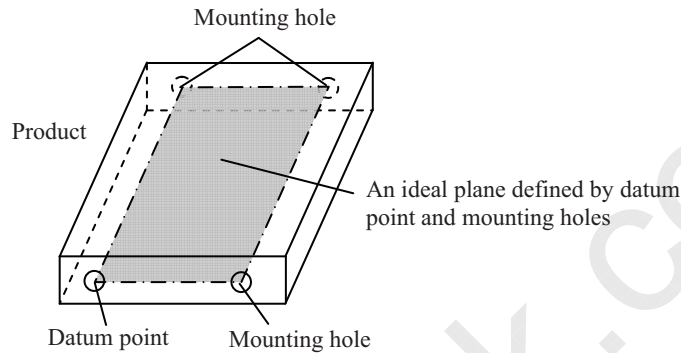

- ⑦ Do not press or rub on the sensitive display surface. If customer clean on the panel surface, NEC recommends using the cloth with ethanolic liquid such as screen cleaner for LCD.
- ⑧ Do not push nor pull the interface connectors while the product is working.
- ⑨ When not connecting FG of the LCD module to the customer's equipment ground, inverter noise may create a beat frequency that will cause video noise on the LCD screen.
- ⑩ When customer handles the product, use of an original protection sheet on the product surface (polarizer) is recommended for protection of product surface. Adhesive type protection sheet may change color or properties of the polarizer.

6.3.2 Environment

- ① Do not operate or store in high temperature, high humidity, dewdrop atmosphere or corrosive gases. Keep the product in packing box and antistatic pouch in room temperature to avoid for dusts and sunlight, when customer stores the product.
- ② In order to prevent dew condensation occurring by temperature difference, the product packing box should be opened after being left under the environment of an unpacking room enough. Because a situation of dew condensation occurring is changed by the environmental temperature and humidity. Evaluate the leaving time sufficiently. (Recommendation leaving time: 6 hour or more with packing state)
- ③ Do not operate in high magnetic field. Circuit boards may be broken down by it.
- ④ This product is not designed as radiation hardened.

6.3.3 Characteristics

The following items are neither defects nor failures.

- ① Response time, luminance and color may be changed by ambient temperature.
- ② The LCD may be seemed luminance non-uniformity, flicker, vertical seam or small spot by display patterns.
- ③ Optical characteristics (e.g. luminance, display uniformity, etc.) gradually is going to change depending on operating time, and especially low temperature, because the LCD has cold cathode fluorescent lamps.
- ④ Do not display the fixed pattern for a long time because it may cause image sticking. Use a screen saver, if the fixed pattern is displayed on the screen.
- ⑤ The display color may be changed by viewing angle because of the use of condenser sheet in the backlight.
- ⑥ Optical characteristics may be changed by input signal timings.
- ⑦ The interference noise of input signal frequency for this product's signal processing board and luminance control frequency of inverter may appear on a display. Set up luminance control frequency of inverter so that the interference noise does not appear.

6.3.4 Other

- ① All VCC and GND terminals should be used without any non-connected lines.
- ② Do not disassemble a product or adjust variable resistors without permission of NEC.
- ③ See "REPLACEMENT MANUAL FOR BACKLIGHT UNIT", if customer would like to replace backlight lamps.
- ④ Pay attention not to insert waste materials inside of products, if customer uses screwnails.
- ⑤ Pack the product with original shipping package, in order to avoid any damages during transportation, when customer returns it to NEC for repair and so on.
- ⑥ The LCD module by itself or integrated into end product should be packed and transported with display in the vertically position. Otherwise the display characteristics may be impaired.



7. OUTLINE DRAWINGS

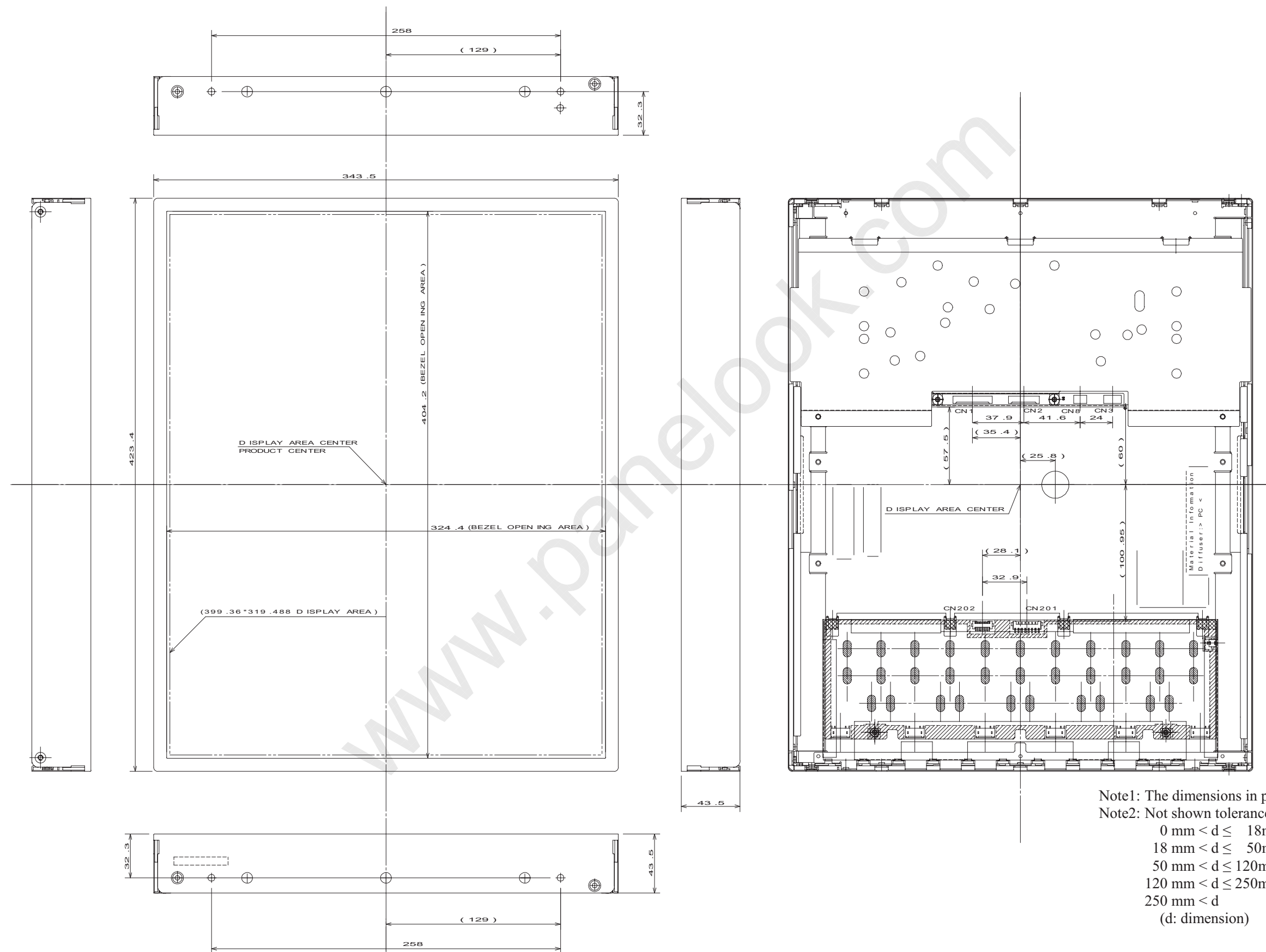

Note1: The dimensions in parenthesis are for reference.

Note2: Not shown tolerances of the dimensions

0 mm < d ≤ 18mm: ±0.2mm.

18 mm < d ≤ 50mm: ±0.3mm.

50 mm < d ≤ 120mm: ±0.4mm.

120 mm < d ≤ 250mm: ±0.5mm.

250 mm < d : ±0.6mm.

(d: dimension)

Unit: mm