

PRELIMINARY

**NEC** NEC LCD Technologies, Ltd.

# TFT COLOR LCD MODULE

**NL4864HL11-01B**

**8.9cm (3.5 Type)**

**VGA**

**PRELIMINARY DATA SHEET** 

**DOD-PP-0144 (1st edition)**

**All information is subject to change without notice.  
Please confirm the sales representative before  
starting to design your system.**

## INTRODUCTION

The Copyright to this document belongs to NEC LCD Technologies, Ltd. (hereinafter called "NEC"). No part of this document will be used, reproduced or copied without prior written consent of NEC.

NEC does and will not assume any liability for infringement of patents, copyrights or other intellectual property rights of any third party arising out of or in connection with application of the products described herein except for that directly attributable to mechanisms and workmanship thereof. No license, express or implied, is granted under any patent, copyright or other intellectual property right of NEC.

Some electronic parts/components would fail or malfunction at a certain rate. In spite of every effort to enhance reliability of products by NEC, the possibility of failures and malfunction might not be avoided entirely. To prevent the risks of damage to death, human bodily injury or other property arising out thereof or in connection therewith, each customer is required to take sufficient measures in its safety designs and plans including, but not limited to, redundant system, fire-containment and anti-failure.

The products are classified into three quality grades: "**Standard**", "**Special**", and "**Specific**" of the highest grade of a quality assurance program at the choice of a customer. Each quality grade is designed for applications described below. Any customer who intends to use a product for application other than that of Standard quality grade is required to contact an NEC sales representative in advance.

The **Standard** quality grade applies to the products developed, designed and manufactured in accordance with the NEC standard quality assurance program, which are designed for such application as any failure or malfunction of the products (sets) or parts/components incorporated therein a customer uses are, directly or indirectly, free of any damage to death, human bodily injury or other property, like general electronic devices.

Examples: Computers, office automation equipment, communications equipment, test and measurement equipment, audio and visual equipment, home electronic appliances, machine tools, personal electronic equipment, industrial robots, etc.

The **Special** quality grade applies to the products developed, designed and manufactured in accordance with an NEC quality assurance program stricter than the standard one, which are designed for such application as any failure or malfunction of the products (sets) or parts/components incorporated therein a customer uses might directly cause any damage to death, human bodily injury or other property, or such application under more severe condition than that defined in the Standard quality grade without such direct damage.

Examples: Control systems for transportation equipment (automobiles, trains, ships, etc.), traffic control systems, anti-disaster systems, anti-crime systems, medical equipment not specifically designed for life support, safety equipment, etc.

The **Specific** quality grade applies to the products developed, designed and manufactured in accordance with the standards or quality assurance program designated by a customer who requires an extremely higher level of reliability and quality for such products.

Examples: Military systems, aircraft control equipment, aerospace equipment, nuclear reactor control systems, medical equipment/devices/systems for life support, etc.

The quality grade of this product is the "**Standard**" unless otherwise specified in this document.

# PRELIMINARY

## CONTENTS

<b>INTRODUCTION .....</b>	<b>2</b>
<b>1. OUTLINE.....</b>	<b>4</b>
1.1 STRUCTURE AND PRINCIPLE.....	4
1.2 APPLICATION.....	4
1.3 FEATURES.....	4
<b>2. GENERAL SPECIFICATIONS .....</b>	<b>5</b>
<b>3. BLOCK DIAGRAM.....</b>	<b>6</b>
<b>4. DETAILED SPECIFICATIONS .....</b>	<b>8</b>
4.1 MECHANICAL SPECIFICATIONS.....	8
4.2 ABSOLUTE MAXIMUM RATINGS .....	8
4.3 ELECTRICAL CHARACTERISTICS .....	9
4.4 SETTING OF THE INTERNAL RESISTER .....	10
4.5 INTERFACE PIN CONNECTIONS .....	13
4.6 DISPLAY COLORS AND INPUT DATA SIGNALS .....	15
4.7 DISPLAY POSITIONS.....	16
4.8 SCANNING DIRECTIONS .....	16
4.9 INPUT SIGNAL TIMINGS.....	17
4.9.1 RGB interface (Ta= 25°C, VCCIO= 3.0V).....	17
4.9.2 Serial interface (Ta= 25°C, VCCIO= 3.0V).....	20
4.10 OPTICAL CHARACTERISTICS .....	21
<b>5. RELIABILITY TESTS.....</b>	<b>24</b>
<b>6. PRECAUTIONS .....</b>	<b>25</b>
6.1 MEANING OF CAUTION SIGNS .....	25
6.2 CAUTIONS .....	25
6.3 ATTENTIONS .....	25
6.3.1 Handling of the product .....	25
6.3.2 Environment.....	26
6.3.3 Characteristics.....	26
6.3.4 Other .....	26
<b>7. OUTLINE DRAWINGS .....</b>	<b>27</b>
<b>8. RECOMMENDATION DESIGN OF FRONT BEZEL .....</b>	<b>28</b>
<b>REVISION HISTORY .....</b>	<b>29</b>

## 1. OUTLINE

### 1.1 STRUCTURE AND PRINCIPLE

Color LCD module NL4864HL11-01B is composed of the low temperature poly silicon thin film transistor liquid crystal display (LTPS TFT LCD) panel structure with driver LSIs for driving the TFT (Thin Film Transistor) array, touch panel (T/P) and a backlight.

The LTPS TFT LCD panel structure is injected liquid crystal material into a narrow gap between the TFT array glass substrate and a color-filter glass substrate.

Color (Red, Green, Blue) data signals from a host system (e.g. signal generator, etc.) are modulated into best form for active matrix system by a controller, and sent to the driver LSIs which drive the individual TFT arrays.

The TFT array as an electro-optical switch regulates the amount of transmitted light from the backlight assembly, when it is controlled by data signals. Color images are created by regulating the amount of transmitted light through the TFT array of red, green and blue dots.

### 1.2 APPLICATION

- PDAs

### 1.3 FEATURES

- Adoption of SR-NLT (Super-Reflective Natural Light TFT) (Transflective type)
- Multi resolution (VGA or QVGA)
- Backlight and touch panel attached
- Including LCD controller and power supply

## 2. GENERAL SPECIFICATIONS

<b>Display area</b>	53.28 (H) × 71.04 (V) mm
<b>Diagonal size of display</b>	8.9cm (3.5 inches)
<b>Drive system</b>	LTPS TFT active matrix
<b>Display color</b>	262,144 colors
<b>Pixel</b>	480 (H) × 640 (V) pixels
<b>Pixel arrangement</b>	RGB (Red dot, Green dot, Blue dot) vertical stripe
<b>Dot pitch</b>	0.037 (H) × 0.111 (V) mm
<b>Pixel pitch</b>	0.111 (H) × 0.111 (V) mm
<b>Module size</b>	(63.5) (H) × (85.0) (V) × (4.2) (D) mm (typ.)
<b>Weight</b>	(43)g (typ.)
<b>Touch panel surface</b>	Clear
<b>Touch panel pencil-hardness</b>	3H (min.) [by JIS K5400]
<b>Designed viewing direction</b>	<ul style="list-style-type: none"> <li>Viewing direction without image reversal: lower side (6 o'clock)</li> <li>Viewing direction with contrast peak: up side (12 o'clock)</li> </ul>
<b>Luminance</b>	At $IL = 20mA$ , With Touch panel (200)cd/m <sup>2</sup> (typ.)
<b>Reflection ratio</b>	With Touch panel (TBD)% (typ.)
<b>Contrast ratio</b>	At $IL = 20mA$ , with Touch panel (TBD) (typ.)
	At reflective mode, with Touch panel (TBD) (typ.)
<b>Response time</b>	$Ton + Toff$ (10% ← → 90%) (TBD) ms (typ.)
<b>Signal system</b>	6-bit digital signals for data of RGB colors, Dot clock (CLK), Horizontal synchronous signal (HSYNC), Vertical synchronous signal (VSYNC) Serial interface (SPI correspondence) (/CS, SCL, SI)
<b>Supply voltage</b>	VCCIO: 3.0V (typ.) VCC: 3.0V (typ.)
<b>Power consumption</b>	LCD panel + Driver: (TBD)mW (typ.) Backlight: (512)mW (typ., at $IL = 20mA$ )

### 3. BLOCK DIAGRAM

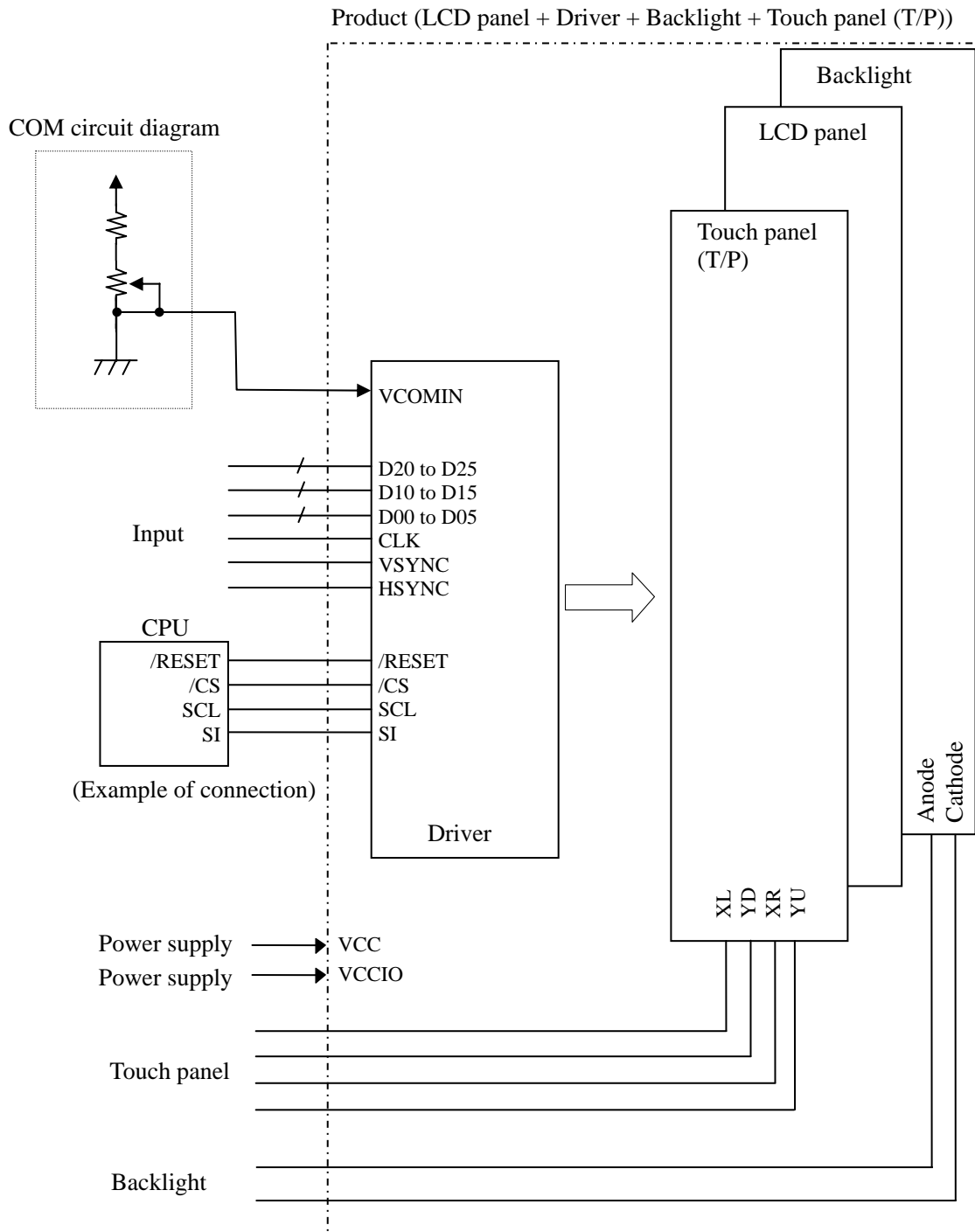

# PRELIMINARY

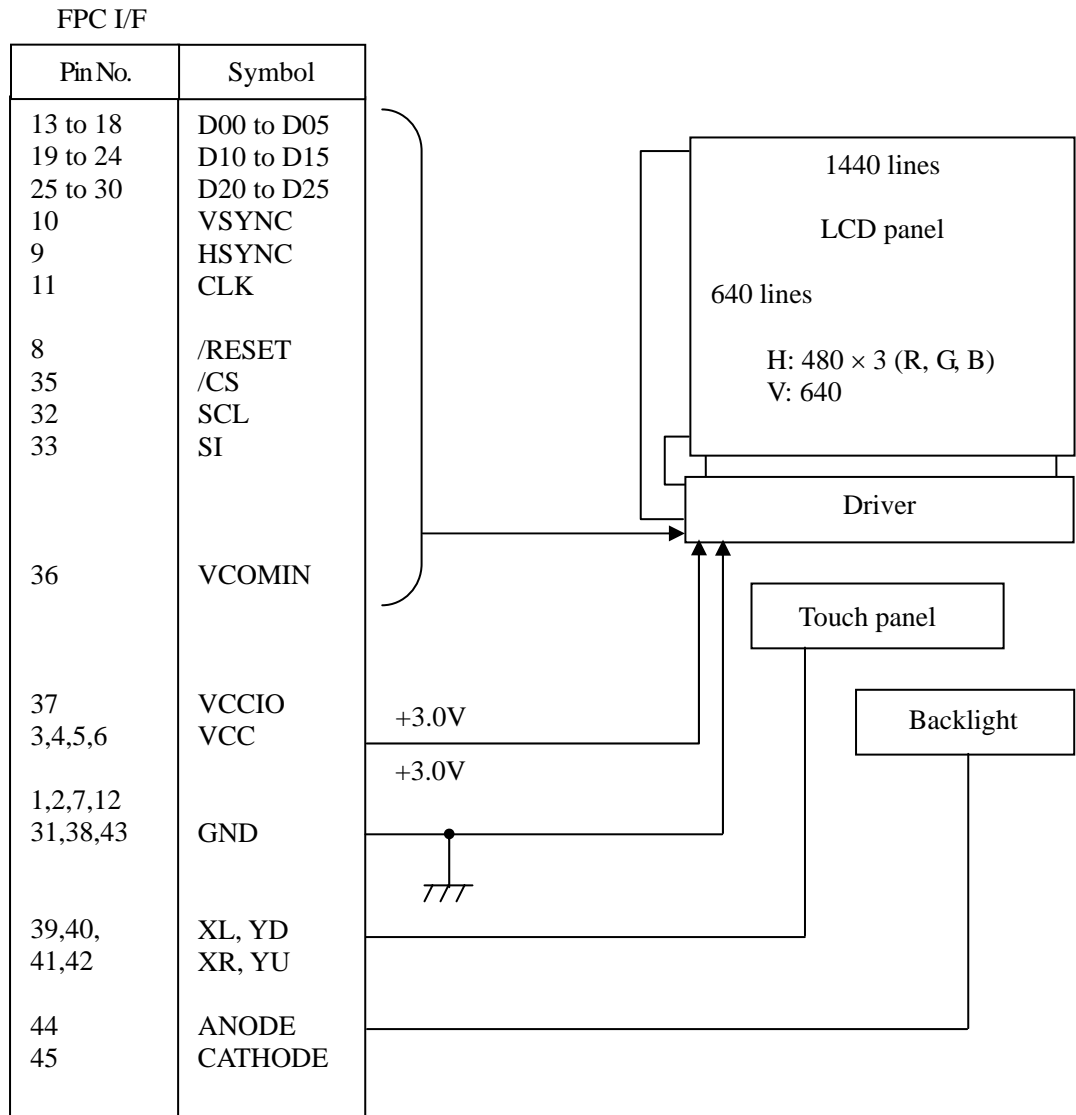

Reference design of COM circuit

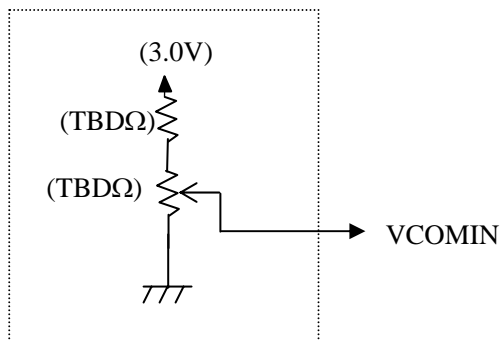

## 4. DETAILED SPECIFICATIONS

### 4.1 MECHANICAL SPECIFICATIONS

Parameter	Specification	Unit
Module size	$(63.5) \pm 0.3$ (W) $\times$ $(85.0) \pm 0.3$ (H) $\times$ $(4.2) \pm 0.2$ (D) Note1	Note2 mm
Display area	53.28 (H) $\times$ 71.04 (V)	Note2 mm
Weight	(43) (typ.), TBD (max.)	g

Note1: Excluding FPC

Note2: See "11. OUTLINE DRAWINGS".

### 4.2 ABSOLUTE MAXIMUM RATINGS

Parameter	Symbol	Rating	Unit	Remarks	
Supply voltage (DC/DC)	VCC	-0.3 to + 3.7	V	Ta= 25°C	
Supply voltage (Logic)	VCCIO	-0.3 to + 6.0	V	Ta= 25°C	
Logic input voltage	VI	-0.3 to VCCIO + 0.3	V	Logic signals	
Backlight	Reverse voltage	VR	( $\leq$ 40)	V	Ta= 25°C
	Power dissipation	PD	( $\leq$ 984)	mW	
	Forward current	IL	Note1	mA	
	Pulse forward current	IFP	(100)	mA	Pulse width $\leq$ 10ms, Duty $\leq$ 1/10
Storage temperature	Tst	(-30 to +70)	°C	-	
Operating temperature	Top	(-20 to +70)		Product surface Note2	
Relative humidity	Note3 RH	$\leq$ 95	%	Ta $\leq$ 40°C	
		$\leq$ 85		40°C < Ta $\leq$ 50°C	
		$\leq$ 55		50°C < Ta $\leq$ 60°C	
Absolute humidity	Note3 AH	$\leq$ 71 Note4	g/m <sup>3</sup>	Ta > 60°C	
Storage altitude		$\leq$ 13,600	m	-30°C $\leq$ Ta $\leq$ 70°C	
Operating altitude		$\leq$ 4,850	m	-20°C $\leq$ Ta $\leq$ 70°C	

Note1: Allowable forward current

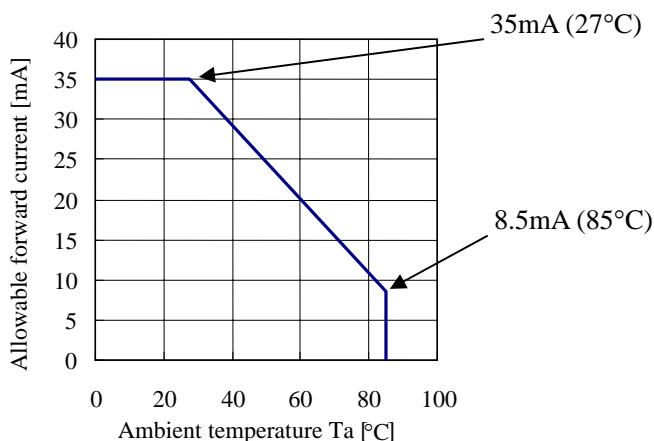

Note2: Measured at display area

Note3: No condensation

Note4: Water amount at Ta= 60°C and RH= 55%



### 4.3 ELECTRICAL CHARACTERISTICS

#### (1) Logic/ LCD driving

(Ta= 25°C)

Parameter	Symbol	min.	typ.	max.	Unit	Remarks
Supply voltage (DC/DC)	VCC	TBD	(3.0)	TBD	V	-
Supply voltage (Logic)	VCCIO	(1.65)	(3.0)	(3.3)	V	-
Logic input high voltage	VIH	0.8VCCIO	-	VCCIO	V	Logic signal
Logic input low voltage	VIL	0	-	0.2VCCIO	V	
VCOM input voltage	VCOMIN	-	TBD	-	V	at VCC= 3.0V Note1
VCC supply current	ICC	-	TBD	TBD	mA	at VCC= 3.0V Note2
VCCIO supply current	ICCIO	-	TBD	TBD	mA	at VCCIO= 3.0V Note2

Note1: The optimum value for VCOMIN is in the range of TBD V to TBD V.

Note2: PPCLK= (19.6)MHz, PPHSYNC= (38.88)kHz, PPVSYNC= (60)Hz,  
 Checkered flag pattern (by EIAJ ED-2522)

#### (2) Backlight

(Ta= 25°C)

Parameter	Symbol	min.	typ.	max.	Unit	Remarks
Forward Current	IL	-	(20)	(22)	mA	-
Forward Voltage	VL	-	(25.6)	(28.0)	V	at IL= 20mA

#### (3) Touch panel

(Ta= 25°C)

Parameter	Symbol	min.	typ.	max.	Unit	Remarks
Touch panel input voltage	Vtp	-	-	(5.5)	V	-
Resistor between pins(XL-XR)	Rx	(190)	-	(500)	Ω	-
Resistor between pins(YU-YD)	Ry	(140)	-	(540)	Ω	-
Line linearity (X direction)	Xlin	-	-	(1.5)	%	-
Line linearity (Y direction)	Ylin	-	-	(1.5)	%	-
Insulation resistance	Rins	(20)	-	-	MΩ	at DC 25V
Static Capacitance	Ctp	-	-	(100)	nF	-
Chattering	Chat	-	-	(10)	ms	-
Operation starting force	Ost	-	-	(0.78)	N	-
				(80)	gf	
Surface hardness	Hs	3	-	-	H	Pencil hardness
Point hitting life	Lhr	1,000,000	-	-	times	Silicon rubber: R8mm, Hardness 60° Load: 2.94N(300gf)

## 4.4 SETTING OF THE INTERNAL RESISTER

Initial setting of the internal Resister is undefined data. So the Resister Data must be written in the Resister, after initialization by the /RESET pin. The Resister Data can be written from serial interface pins (/CS, SCL and SI). This serial interface supports SPI. The setting method is as follows.

### (1) Command Byte Function

Bits	Functions	Discription
A7	-	-
A6	-	-
A5	Read / Write	0:Write 1:Read
A4	-	-
A3	-	-
A2	-	-
A1	-	-
A0	Register Number / Data	0:Register Number 1:Register Data

### (2) Timing chart

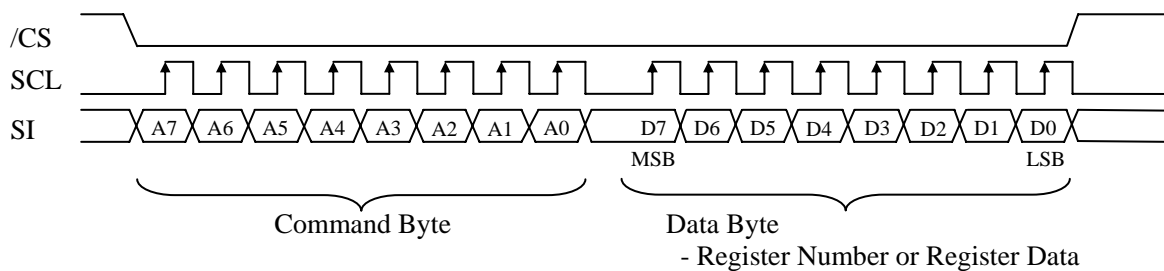

### Ex) When data 55h is written to Register R26 (R1Ah)

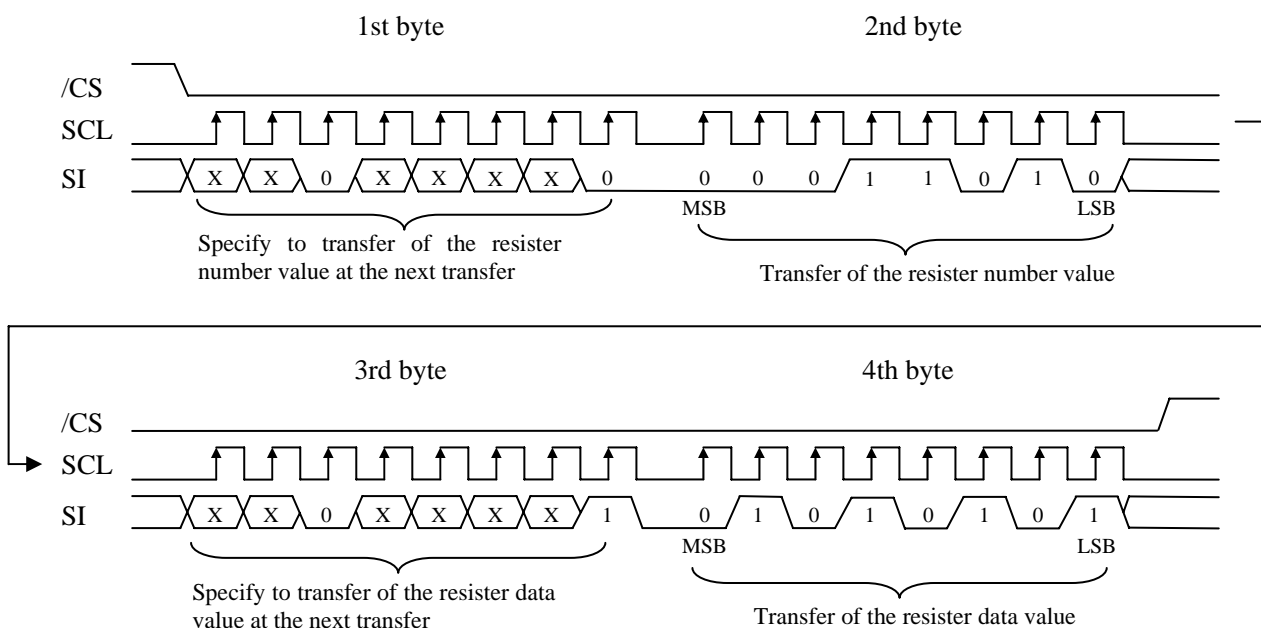

Note1: During 32-bit transfer of the Resister Data, /CS pin (Pin No.35) must be maintained active.

Note2: "X" is set in accordance with the usage conditions.

Note3: Please transmit the data transfer every 32 bits.

# PRELIMINARY

Command sequence

① Power On

Sequence	Register Number	Data	Comment	Sequence	Register Number	Data	Comment
1	Power On			32	R43	(09h)	-
2	200us min. wait.			33	R44	(02h)	-
3	R3	(01h)	-	34	R45	(0Eh)	-
4	R0	(00h)	-	35	R46	(14h)	-
5	R1	(09h)	-	36	R47	(0Ch)	-
6	R4	(07h)	-	37	R48	(0Fh)	-
7	R5	(14h)	-	38	R49	(1Dh)	-
8	R6	(24h)	-	39	R50	(03h)	-
9	R16	(CFh)	-	40	R51	(02h)	-
10	R17	(03h)	-	41	R52	(02h)	-
11	R18	(00h)	-	42	R53	(02h)	-
12	R19	(55h)	-	43	R80	(02h)	-
13	R20	(01h)	-	44	R83	(42h)	-
14	R21	(70h)	-	45	R84	(42h)	-
15	R22	(23h)	-	46	R85	(0Fh)	-
16	R23	(37h)	-	47	R86	(0Ah)	-
17	R24	(37h)	-	48	R89	(08h)	-
18	R25	(FFh)	-	49	R90	(01h)	-
19	R26	(02h)	-	50	R91	(0Ah)	-
20	R27	(80h)	-	51	R92	(0Fh)	-
21	R32	(29h)	-	52	R93	(0Ah)	-
22	R33	(02h)	-	53	R94	(57h)	-
23	R34	(0Eh)	-	54	R95	(18h)	-
24	R35	(14h)	-	55	R98	(3Bh)	-
25	R36	(0Ch)	-	56	R99	(18h)	-
26	R37	(0Fh)	-	57	R102	(1Fh)	-
27	R38	(1Dh)	-	58	R103	(18h)	-
28	R39	(03h)	-	59	R116	(0Ah)	-
29	R40	(02h)	-	60	20us min. wait		
30	R41	(02h)	-	61	R2	(00h)	-
31	R42	(02h)	-				

# PRELIMINARY

② Power Off

Sequence	Register Number	Data	Comment
1	R16	05h	-
2	20 us min. wait.		
3	R16	01h	-
4	20 us min. wait.		
5	R16	00	
6	20 us min. wait.		
7	R3	01h	-
8	Power Off		

# PRELIMINARY

## 4.5 INTERFACE PIN CONNECTIONS

CN1 (FPC)

Adaptable socket: FH23-45S-0.3SHW(05) (Hirose Electric Co., Ltd.(HRS))

Pin No.	Symbols	Functions	Pin No.	Symbols	Functions
1	GND	Ground Note1	25	D20	Red data (LSB)
2	GND	Ground Note1	26	D21	Red data
3	VCC	Power supply Note1	27	D22	Red data
4	VCC		28	D23	Red data
5	VCC		29	D24	Red data
6	VCC		30	D25	Red data (MSB)
7	GND	Ground Note1	31	GND	Ground Note1
8	/RESET	Reset	32	SCL	Serial clock
9	HSYNC	Horizontal synchronous signal	33	SI	Serial input
10	VSYNC	Vertical synchronous signal	34	RSVD	Keep this pin Open.
11	CLK	Dot clock	35	/CS	Chip selection
12	GND	Ground Note1	36	VCOMIN	COM high voltage input
13	D00	Blue data (LSB)	37	VCCIO	Power supply (Logic)
14	D01	Blue data	38	GND	Ground Note1
15	D02	Blue data	39	XL	Horizontal terminal (Left side)
16	D03	Blue data	40	YD	Vertical terminal (Down side)
17	D04	Blue data	41	XR	Horizontal terminal (Right side)
18	D05	Blue data (MSB)	42	YU	Vertical terminal (Up side)
19	D10	Green data (LSB)	43	GND	Ground Note1
20	D11	Green data	44	ANODE	LED voltage (Anode)
21	D12	Green data	45	CATHODE	LED voltage (Cathode)
22	D13	Green data			
23	D14	Green data			
24	D15	Green data (MSB)			

Note1: All GND terminals should be used without any non-connected lines.

Note2: Do not fold the FPC. When folding the FPC, pattern disconnection may occur. In case of bending FPC, the minimum curvature (R) must be more than 1.0 mm.

# PRELIMINARY

## Description of terminals

Terminals	Description
/RESET	When /RESET is L, an internal reset is performed. The reset operation is executed at the /RESET signal level. Be sure to perform reset via this pin at power application.
/CS	This pin is used for chip select signals. When /CS= L, the chip is active and can perform data I/O operations including command and data I/O.
SCL	This pin is clock input of serial interface.
SI	This pin is data input of serial interface.
VCOMIN	This pin is the Common input voltage. The voltage needs to be adjusted. The details are explained the above. See "3 BLOCK DIAGRAM - Reference design of COM circuit".
YU, XR, YD, XL	Refer to the below "Circuits of touch panel".
ANODE, CATHODE	Refer to the below "Circuits of backlight".

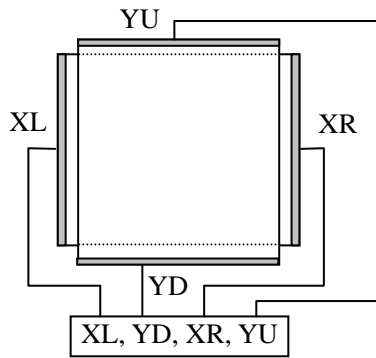

Circuits of touch panel

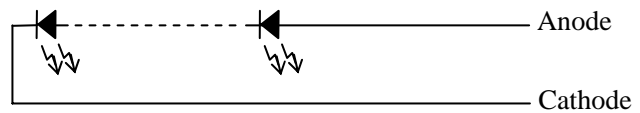

Circuits of backlight

# PRELIMINARY

## 4.6 DISPLAY COLORS AND INPUT DATA SIGNALS

This product can display in equivalent to 262,144 colors in 64 gray scales. Also the relation between display colors and input data signals is as the following table.

Display colors		Data signal (0: Low level, 1: High level)																	
		R5	R4	R3	R2	R1	R0	G5	G4	G3	G2	G1	G0	B5	B4	B3	B2	B1	B0
Basic colors	Black	0	0	0	0	0	0	0	0	0	0	0	0	0	0	0	0	0	0
	Blue	0	0	0	0	0	0	0	0	0	0	0	0	1	1	1	1	1	1
	Red	1	1	1	1	1	1	0	0	0	0	0	0	0	0	0	0	0	0
	Magenta	1	1	1	1	1	1	0	0	0	0	0	0	1	1	1	1	1	1
	Green	0	0	0	0	0	0	1	1	1	1	1	1	0	0	0	0	0	0
	Cyan	0	0	0	0	0	0	1	1	1	1	1	1	1	1	1	1	1	1
	Yellow	1	1	1	1	1	1	1	1	1	1	1	1	0	0	0	0	0	0
	White	1	1	1	1	1	1	1	1	1	1	1	1	1	1	1	1	1	1
Red gray scale	Black	0	0	0	0	0	0	0	0	0	0	0	0	0	0	0	0	0	0
		0	0	0	0	0	1	0	0	0	0	0	0	0	0	0	0	0	0
	dark	0	0	0	0	1	0	0	0	0	0	0	0	0	0	0	0	0	0
	↑				:					:						:			
	↓				:					:						:			
bright	1	1	1	1	0	1	0	0	0	0	0	0	0	0	0	0	0	0	
	1	1	1	1	1	0	0	0	0	0	0	0	0	0	0	0	0	0	
Red	1	1	1	1	1	1	0	0	0	0	0	0	0	0	0	0	0	0	
Green gray scale	Black	0	0	0	0	0	0	0	0	0	0	0	0	0	0	0	0	0	0
		0	0	0	0	0	0	0	0	0	0	1	0	0	0	0	0	0	0
	dark	0	0	0	0	0	0	0	0	0	0	1	0	0	0	0	0	0	0
	↑				:					:						:			
	↓				:					:						:			
bright	0	0	0	0	0	0	1	1	1	1	0	1	0	0	0	0	0	0	
	0	0	0	0	0	0	1	1	1	1	1	0	0	0	0	0	0	0	
Green	0	0	0	0	0	0	1	1	1	1	1	1	0	0	0	0	0	0	
Blue gray scale	Black	0	0	0	0	0	0	0	0	0	0	0	0	0	0	0	0	0	0
		0	0	0	0	0	0	0	0	0	0	0	0	0	0	0	0	0	1
	dark	0	0	0	0	0	0	0	0	0	0	0	0	0	0	0	0	1	0
	↑				:					:						:			
	↓				:					:						:			
bright	0	0	0	0	0	0	0	0	0	0	0	0	1	1	1	1	0	1	
	0	0	0	0	0	0	0	0	0	0	0	0	1	1	1	1	1	0	
Blue	0	0	0	0	0	0	0	0	0	0	0	0	1	1	1	1	1	1	

## 4.7 DISPLAY POSITIONS

The following table is the coordinates per pixel (See figure of "4.8 SCANNING DIRECTIONS".).

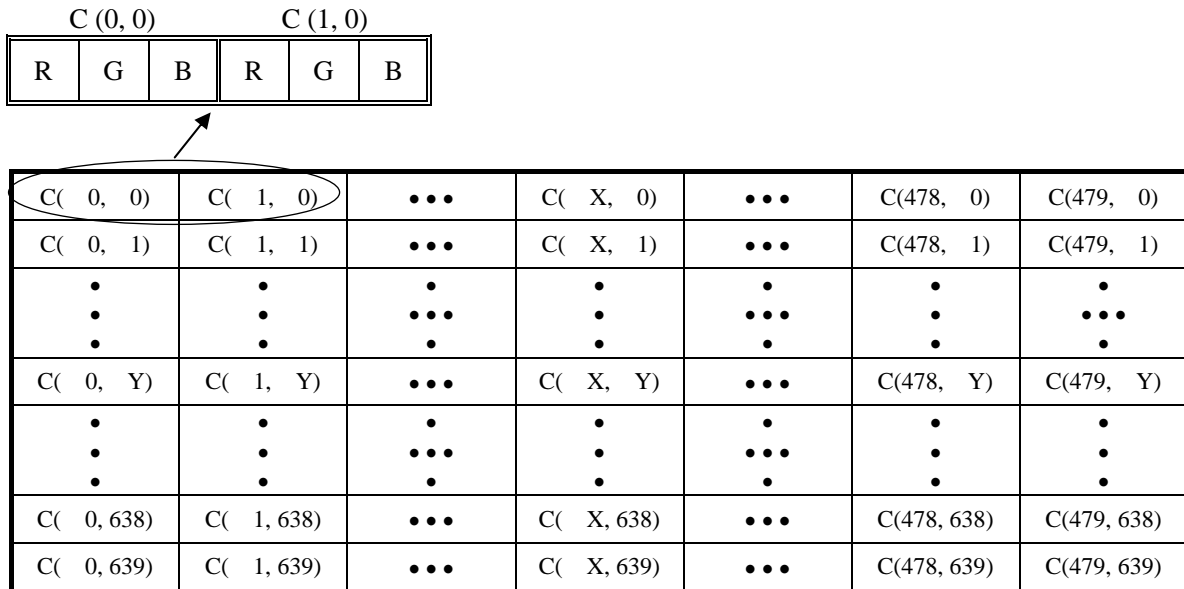

## 4.8 SCANNING DIRECTIONS

The following figures are seen from a front view. Also the arrow shows the direction of scan.

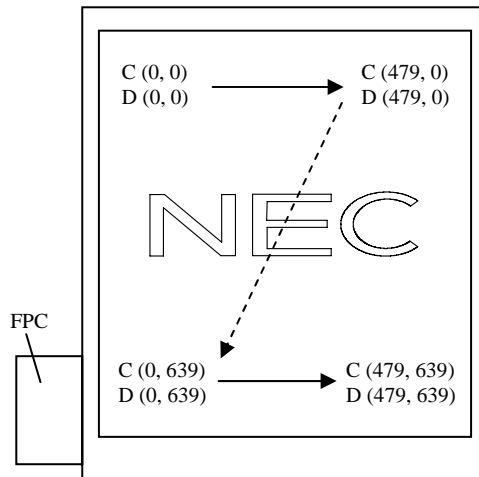

Note1: Meaning of C (X, Y) and D (X, Y)

C (X, Y): The coordinates of the display position (See "4.7 DISPLAY POSITIONS".)

D (X, Y): The data number of input signal for LCD panel



## 4.9 INPUT SIGNAL TIMINGS

### 4.9.1 RGB interface (Ta= 25°C, VCCIO= 3.0V)

#### (1) Timing characteristics

Parameter		Symbol	min.	typ.	max.	Unit	Remarks	
CLK	Frequency	1/tc	TBD	(19.6)	TBD	MHz	(51ns) (typ.)	
	Duty	tcd	0.4	0.5	0.6	-	-	
	Rise time, Fall time	tcrf	-	-	(2)	ns		
DATA (D00-05) (D10-15) (D20-25)	CLK-DATA	Setup time	tds	(25)	-	-	ns	-
		Hold time	tdh	(25)	-	-	ns	
	Rise time, Fall time	tdrf	-	-	(2)	ns		
HSYNC	Cycle	th	TBD	(25.72)	TBD	μs	(38.88kHz) (typ.)	
			(504)			CLK	-	
	Display period	thd	480			CLK		
	Front-porch	thf	(19)			CLK		
	Pulse width	thp	(1)			CLK		
	Back-porch	thb	(4)			CLK		
	CLK- HSYNC	Setup time	ths	(25)	-	-		ns
		Hold time	thh	(25)	-	-		ns
Rise time, Fall time	thrf	-	-	(2)	ns			
VSYNC	Cycle	tv	TBD	(16.59)	TBD	ms	(60Hz) (typ.)	
			(648)			H	-	
	Display period	tvd	640			H		
	Front-porch	tvf	(1)			H		
	Pulse width	tvp	(1)			H		
	Back-porch	tvb	(6)			H		
	VSYNC-HSYNC timing	tvh	TBD	-	-	ns		
	Rise time, Fall time	tvrf	-	-	(2)	ns		

Note1: Definition of parameters is as follows.

tc= 1CLK, tcd= tch/tc, th= 1H

Note2: All parameters should be kept within the specified range.

# PRELIMINARY

(2) Input signal timing chart

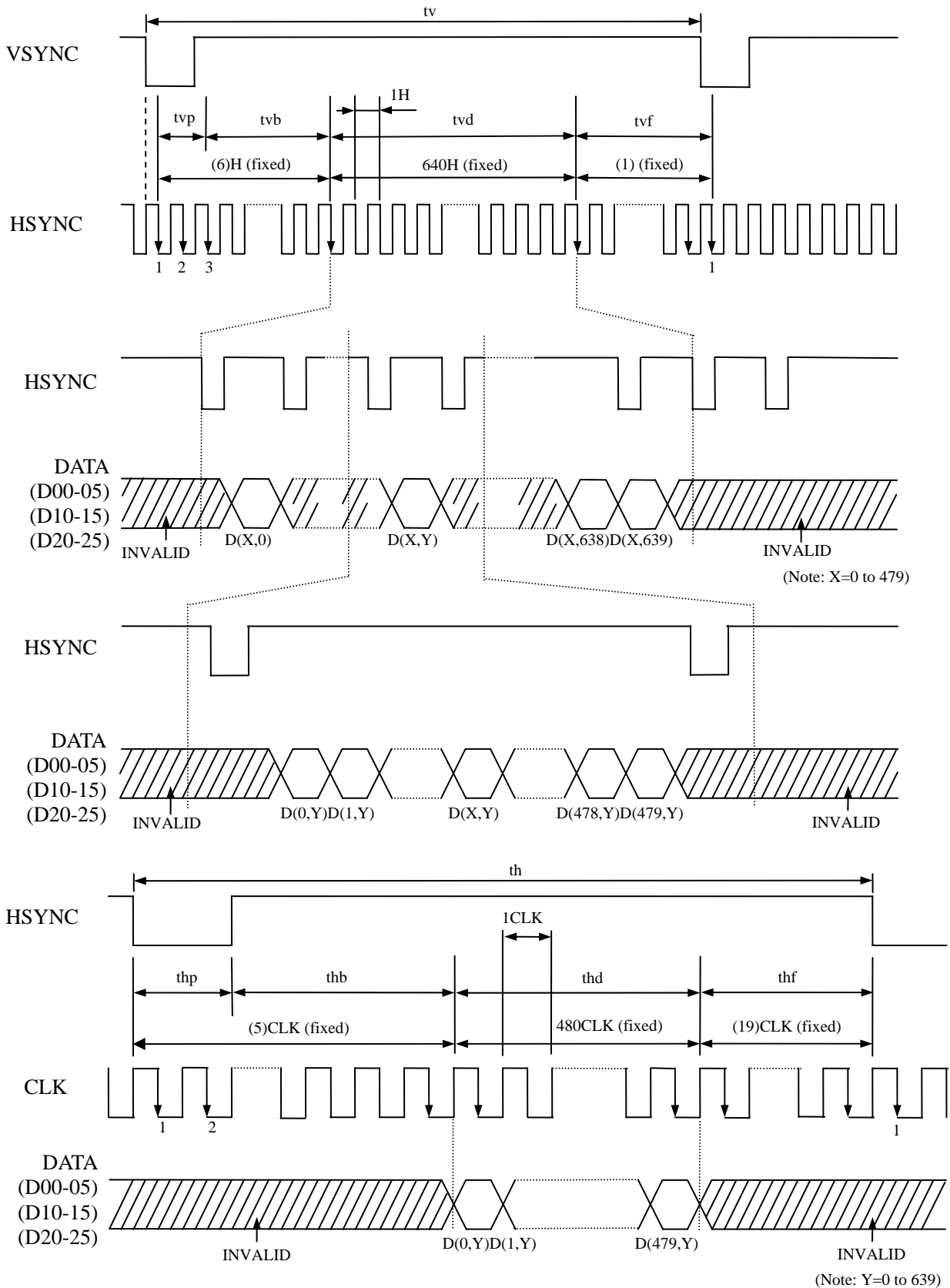

Note1: Unless otherwise specified, the input level is defined to be  $V_{IH} = 0.8V_{CCIO}$ ,  $V_{IL} = 0.2V_{CCIO}$ .

# PRELIMINARY

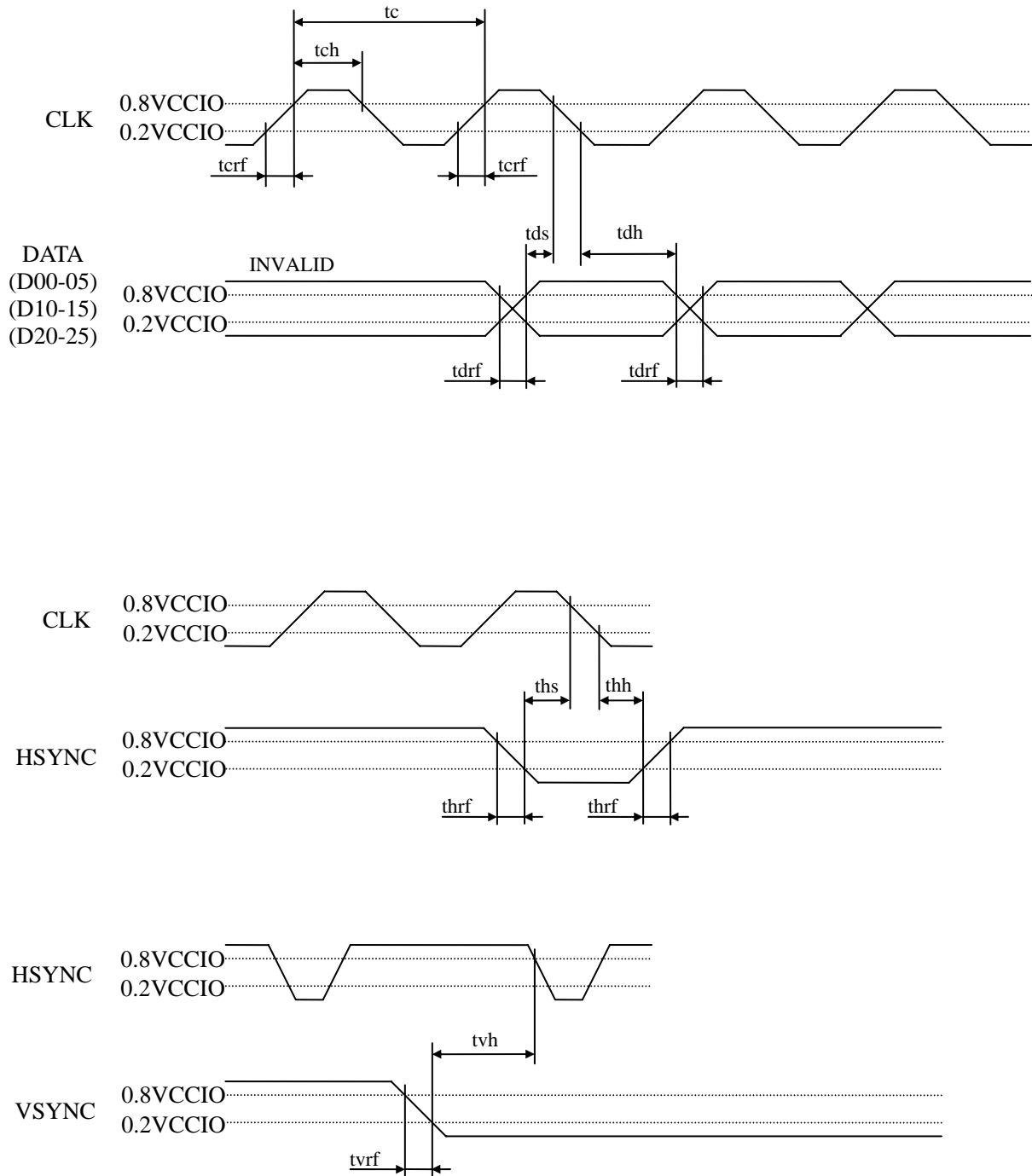

Note1: Unless otherwise specified, the input level is defined to be  $V_{IH} = 0.8V_{CCIO}$ ,  $V_{IL} = 0.2V_{CCIO}$ .

4.9.2 Serial interface (Ta= 25°C, VCCIO= 3.0V)

(1) Timing characteristics

Parameter	Symbol	Condition	min.	typ.	max.	Unit	Remarks
Serial clock cycle	tSCYC	SCL	(100)	-	-	ns	-
SCL high level pulse width	tSHW	SCL	(50)	-	-	ns	-
SCL low level pulse width	tSLW	SCL	(50)	-	-	ns	-
/CS rise time, fall time	tcsrf	/CS	-	-	(2)	ns	-
SCL rise time, fall time	tscrf	SCL	-	-	(2)	ns	-
SI rise time, fall time	tsirf	SI	-	-	(2)	ns	-
/CS setup time	tCSS	/CS	(50)	-	-	ns	-
/CS hold time	tCSH	/CS	(50)	-	-	ns	-
Data setup time	tSDS	SI	(50)	-	-	ns	-
Data hold time	tSDH	SI	(50)	-	-	ns	-
Reset pulse width	tRW	/RESET	(10)	-	-	μs	-
/RESET↑ to /CS time	tRCS	/RESET↑ to /CS	TBD	-	-	μs	-

Note1: All parameters should be kept within the specified range.

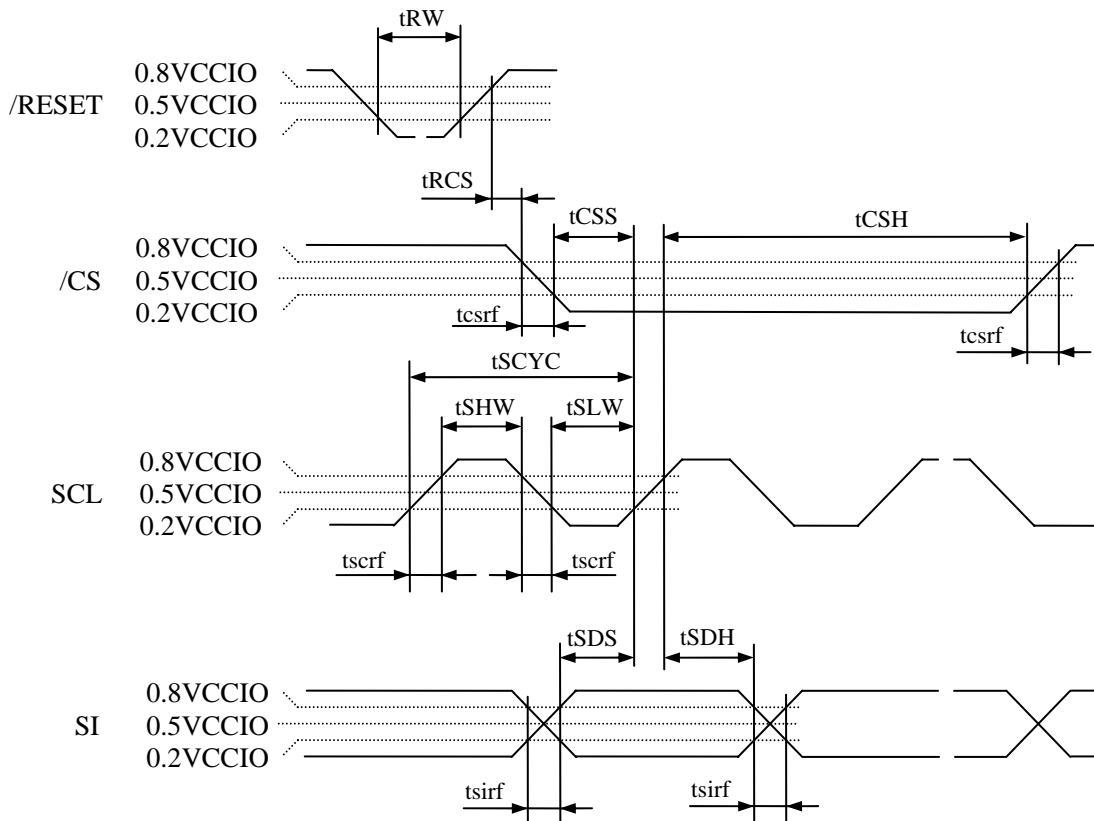

Note2: Unless otherwise specified, the input level is defined to be VIH= 0.8VCCIO, VIL= 0.2VCCIO.

# PRELIMINARY

## 4.10 OPTICAL CHARACTERISTICS

<Backlight turning OFF>

(Note1, Note3, Note4)

Parameter	Condition	Symbol	min.	typ.	max.	Unit	Remarks
Reflection ratio	White, at center	RE	TBD	TBD	-	%	Note6
Contrast ratio	White/Black, at center	CR	TBD	TBD	-	-	Note7

<Backlight turning ON>

(Note2, Note3, Note5)

Parameter	Condition	Symbol	min.	typ.	max.	Unit	Remarks
Luminance	White at center $\theta R=0^\circ, \theta L=0^\circ, \theta U=0^\circ, \theta D=0^\circ$	L	TBD	(200)	-	cd/m <sup>2</sup>	-
Contrast ratio	White/Black at center $\theta R=0^\circ, \theta L=0^\circ, \theta U=0^\circ, \theta D=0^\circ$	CR	TBD	TBD	-	-	Note7
Luminance uniformity	White $\theta R=0^\circ, \theta L=0^\circ, \theta U=0^\circ, \theta D=0^\circ$ Maximum luminance: 100%	LU	TBD	(70)	-	%	Note11

Reference data

(Note2, Note3, Note5)

Parameter	Condition	Symbol	min.	typ.	max.	Unit	Remarks	
Chromaticity coordinates	White	Wx	TBD	TBD	TBD	-	Note8	
		Wy	TBD	TBD	TBD	-		
Color gamut	$\theta R=0^\circ, \theta L=0^\circ, \theta U=0^\circ, \theta D=0^\circ$ at center, against NTSC color space	C	-	TBD	-	%		
Response time	White to black	90% → 10%	Ton	-	TBD	TBD	ms	Note9 Note10
	Black to white	10% → 90%	Toff	-	TBD	TBD		
Viewing angle	Right	$\theta U=0^\circ, \theta D=0^\circ, CR \geq 5$	$\theta R$	-	TBD	-	°	-
	Left	$\theta U=0^\circ, \theta D=0^\circ, CR \geq 5$	$\theta L$	-	TBD	-	°	
	Up	$\theta R=0^\circ, \theta L=0^\circ, CR \geq 5$	$\theta U$	-	TBD	-	°	
	Down	$\theta R=0^\circ, \theta L=0^\circ, CR \geq 5$	$\theta D$	-	TBD	-	°	

# PRELIMINARY

Note1: Measurement conditions are as follows.

$T_a = 25^\circ\text{C}$ ,  $V_{CC} = 3.0\text{V}$ ,  $V_{CCIO} = 3.0\text{V}$

Note2: Measurement conditions are as follows.

$T_a = 25^\circ\text{C}$ ,  $V_{CC} = 3.0\text{V}$ ,  $V_{CCIO} = 3.0\text{V}$ ,  $I_L = 20\text{mA}$

Note3: Definition of viewing angles

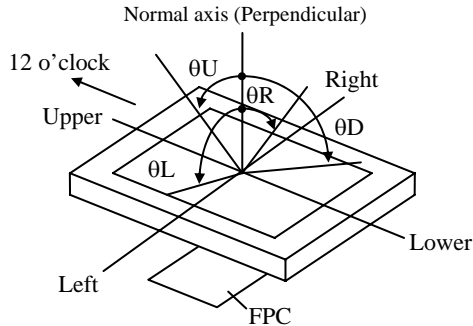

Note4: In reflective mode (Backlight turning OFF), Reflection ratio, Contrast ratio, Chromaticity coordinates and Color gamut are measured as follows.

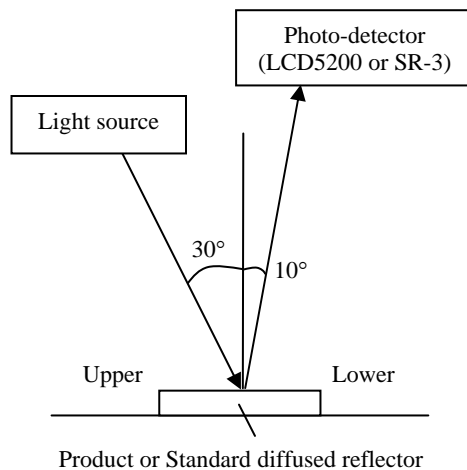

Note5: In transmissive mode (Backlight turning ON), Luminance, Contrast ratio, Chromaticity coordinates and Color gamut are measured as follows.

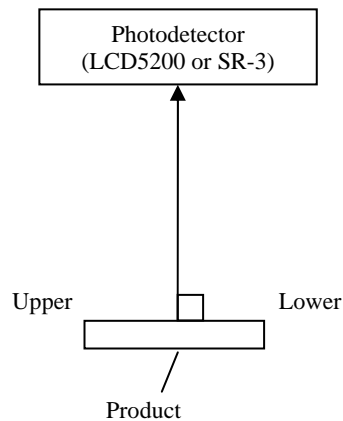

Note6: Definitions of reflection ratio

The reflection ratio is calculated by using the following formula.

$$\text{Reflection (RE)} = \frac{\text{Luminance of reflected light at white screen}}{\text{Luminance of standard diffused reflector}} \times 100$$

Note7: Definition of contrast ratio

The contrast ratio is calculated by using the following formula.

$$\text{Contrast ratio (CR)} = \frac{\text{Luminance of white screen}}{\text{Luminance of black screen}}$$

Note8: The White chromaticity coordinates are deviated by the LED deviation in addition to color filter deviation.

Note9: Definition of response times

Response time is measured, the luminance changes from "white" to "black", or "black" to "white" on the same screen point, by photo-detector. Ton is the time it takes the luminance change from 90% down to 10%. Also Toff is the time it takes the luminance change from 10% up to 90% (See the following diagram.).

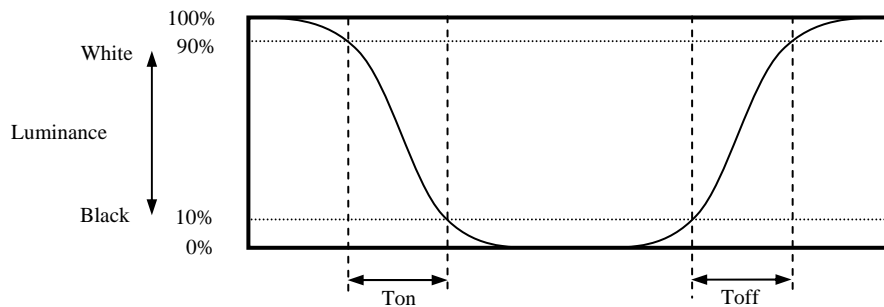

Note10: Product surface temperature: Top= 25°C

Note11: Definition of luminance uniformity

Luminance uniformity is calculated by using the following formula.

$$\text{Luminance uniformity (LU)} = \frac{\text{Minimum luminance from A to I}}{\text{Maximum luminance from A to I}} \times 100$$

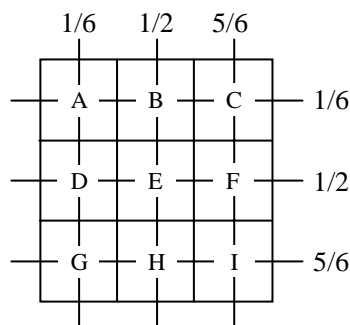

# PRELIMINARY

## 5. RELIABILITY TESTS

TBD



## 6. PRECAUTIONS

### 6.1 MEANING OF CAUTION SIGNS

The following caution signs have very important meaning. **Be sure to read "6.2 CAUTIONS" and "6.3 ATTENTIONS", after understanding these contents!**



This sign has the meaning that customer will be injured by himself or the product will sustain a damage, if customer has wrong operations.



This sign has the meaning that customer will get an electrical shock, if customer has wrong operations.



This sign has the meaning that customer will be injured by himself, if customer has wrong operations.

### 6.2 CAUTIONS



**\* Do not touch the working backlight. There is a danger of an electric shock.**



**\* Do not touch the working backlight. There is a danger of burn injury.**  
**\* Do not shock and press the LCD panel and the backlight! There is a danger of breaking, because they are made of glass. (Shock: To be not greater TBD m/s<sup>2</sup> and to be not greater TBD ms)**

### 6.3 ATTENTIONS



#### 6.3.1 Handling of the product

- ① Take hold of both ends without touching the FPC when the product (LCD module) is picked up from the tray.
- ② Do not hook nor pull the FPC in order to avoid any damage.
- ③ When the product is put on the table temporarily, display surface must be placed downward.
- ④ When handling the product, take the measures of electrostatic discharge with such as earth band, ionic shower and so on, because the product may be damaged by electrostatic.
- ⑤ The product must be installed and/or handled without undue stress such as bends or twist. Bends, twist or undue stress to any portion may cause display failures. And also do not put heavy or hard materials on the product.
- ⑥ Do not hit or rub the surface of touch panel with hard materials, because it is easily scratched. (Touch panel pencil-hardness: 3H)
- ⑦ When cleaning the T/P surface, wipe it with a soft dry cloth.
- ⑧ Do not push nor pull the FPC while the product is working.
- ⑨ Do not fold the FPC. When the FPC is folded, pattern disconnection may be caused. In case of bending FPC, the minimum curvature (R) must be more than 1.0 mm.
- ⑩ When installing the product, do not contact a conductor such as a metal to the FPC excluding the terminal area. There is a risk of short circuit which is caused by breakage of insulation layer of the FPC.
- ⑪ When installing the product, apply the waterproof design to avoid going of water into the product.

### 6.3.2 Environment

- ① Do not operate or store in high temperature, high humidity, dewdrop atmosphere or corrosive gases. Keep the product in packing box with antistatic pouch in room temperature to avoid for dusts and sunlight, when storing the product.
- ② In order to prevent dew condensation occurring by temperature difference, the product packing box should be opened after enough time being left under the environment of an unpacking room. Evaluate the leaving time sufficiently because a situation of dew condensation occurring is changed by the environmental temperature and humidity. (Recommended leaving time: 6 hours or more with packing state)
- ③ Do not operate in high magnetic field. Circuits may be broken down by it.
- ④ This product is not designed as radiation hardened.

### 6.3.3 Characteristics

**The following items are neither defects nor failures.**

- ① Response time, luminance and color may be changed by ambient temperature.
- ② Display mura, flicker, vertical seam or small spot may be observed depending on display patterns.
- ③ Do not display the fixed pattern for a long time because it may cause image sticking.
- ④ Optical characteristics may be changed depending on input signal timings.
- ⑤ Touch panel film has polarizing characteristic. And the polarizer characteristics differ among products. Therefore, when seeing the displays through the other polarizing material (for example polarizing sunglasses), some displays can not be seen and some displays look different color darker because of polarizer characteristic mismatching between touch panel film and the other polarizing material.

### 6.3.4 Other

- ① All GND terminals should be used without any non-connected lines.
- ② Do not disassemble the product.
- ③ Pack the product with original shipping package, in order to avoid any damages during transportation, when returning the product to NEC.

## 7. OUTLINE DRAWINGS

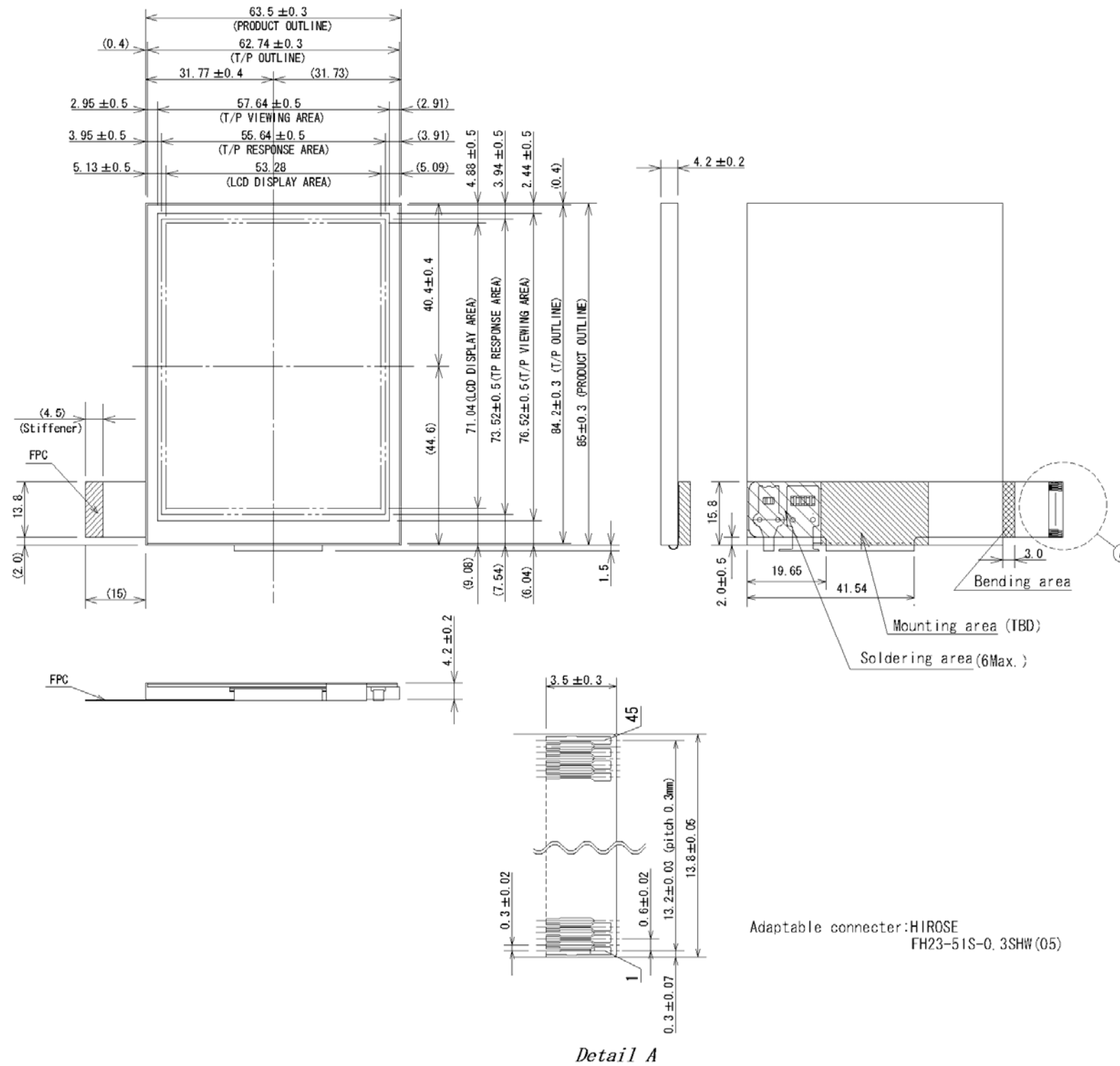

Adaptable connector: HIROSE  
FH23-51S-0.3SHW(05)

Pin No.	Symbols	Pin No.	Symbols
1	GND	25	D20
2	GND	26	D21
3	VCC	27	D22
4	VCC	28	D23
5	VCC	29	D24
6	VCC	30	D25
7	GND	31	GND
8	/RESET	32	SCL
9	HSYNC	33	SI
10	VSYNC	34	RSVD
11	CLK	35	/CS
12	GND	36	VCOMIN
13	D00	37	VCCIO
14	D01	38	GND
15	D02	39	XL
16	D03	40	YD
17	D04	41	XR
18	D05	42	YU
19	D10	43	GND
20	D11	44	ANODE
21	D12	45	CATHODE
22	D13		
23	D14		
24	D15		

Note1: The values in parentheses are for reference.

Note2: When installing the product to customer equipment, do not apply undue stress to the rear side of the product, FPC, A area, Soldering Area and Mounting Area.

If not, it may cause display un-uniformity or break down of the product.

Note3: While the product is working, do not contact a conductor such as a metal to the Soldering Area and Mounting Area of the FPC.

Unit: mm

## 8. RECOMMENDATION DESIGN OF FRONT BEZEL

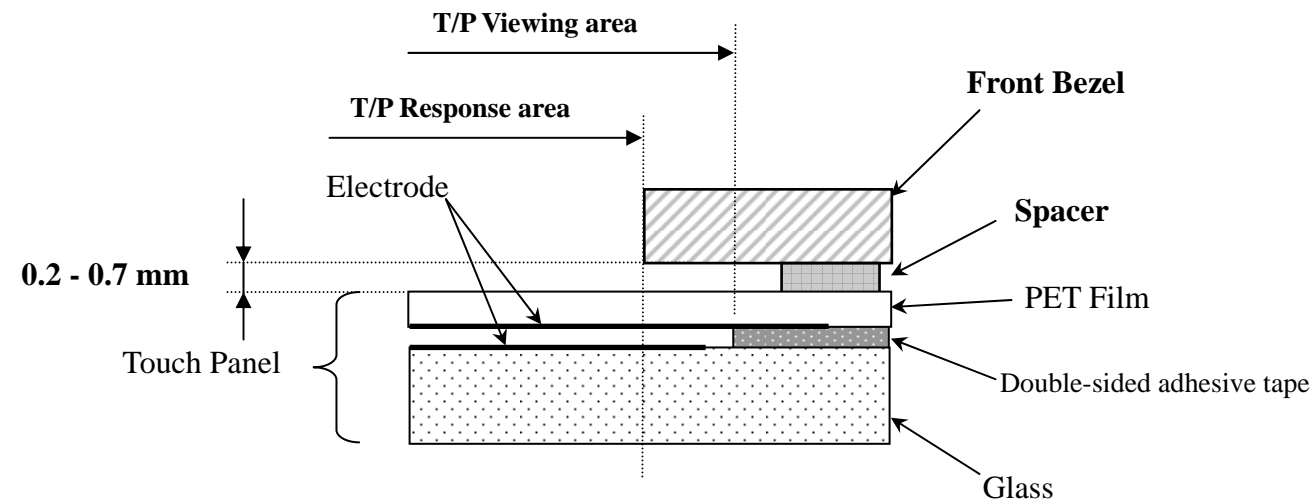

### Design guidance for the front bezel and the spacer

1. Front Bezel opening design
  - a. Please place the front bezel opening to maintain the operation by a stylus pen inside the T/P response area.
  - b. The any pressures in the area between T/P response area and T/P viewing area is prohibited. Please use the appropriate material as the front bezel.
2. Spacer design
  - a. Please put the spacer, a cushion, on the front bezel. Do not use a double-sided adhesive tape because it adheres on the touch panel surface.
  - b. Please position the spacer over the Spacer area to avoid a “short”.

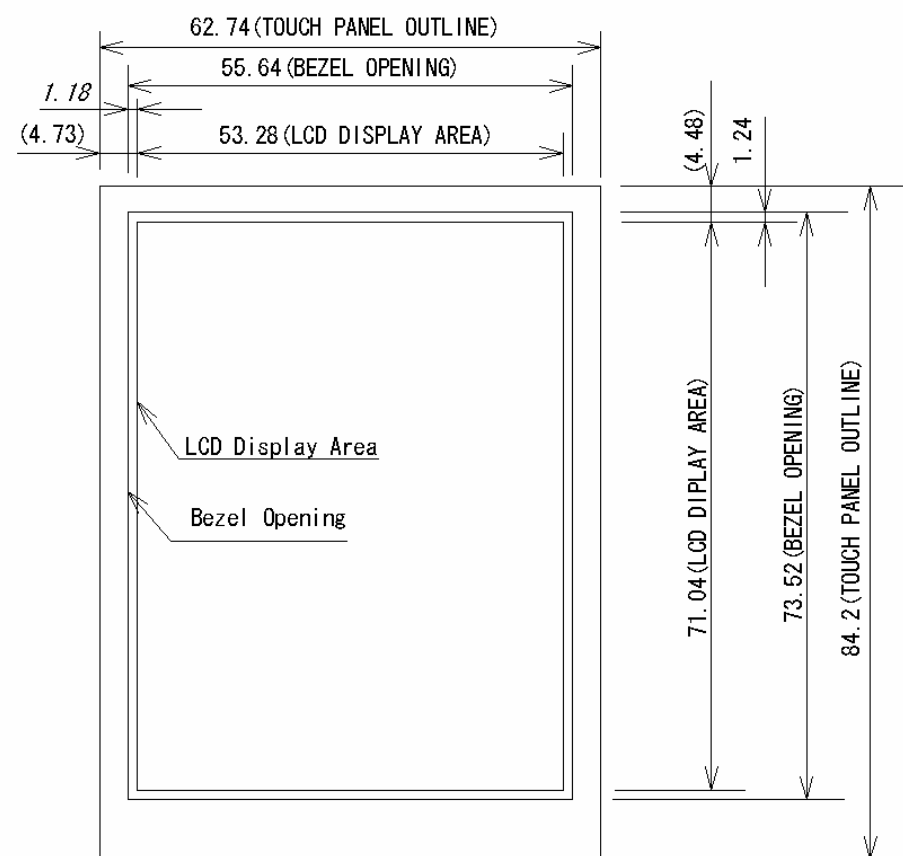

Front Bezel Opening Design

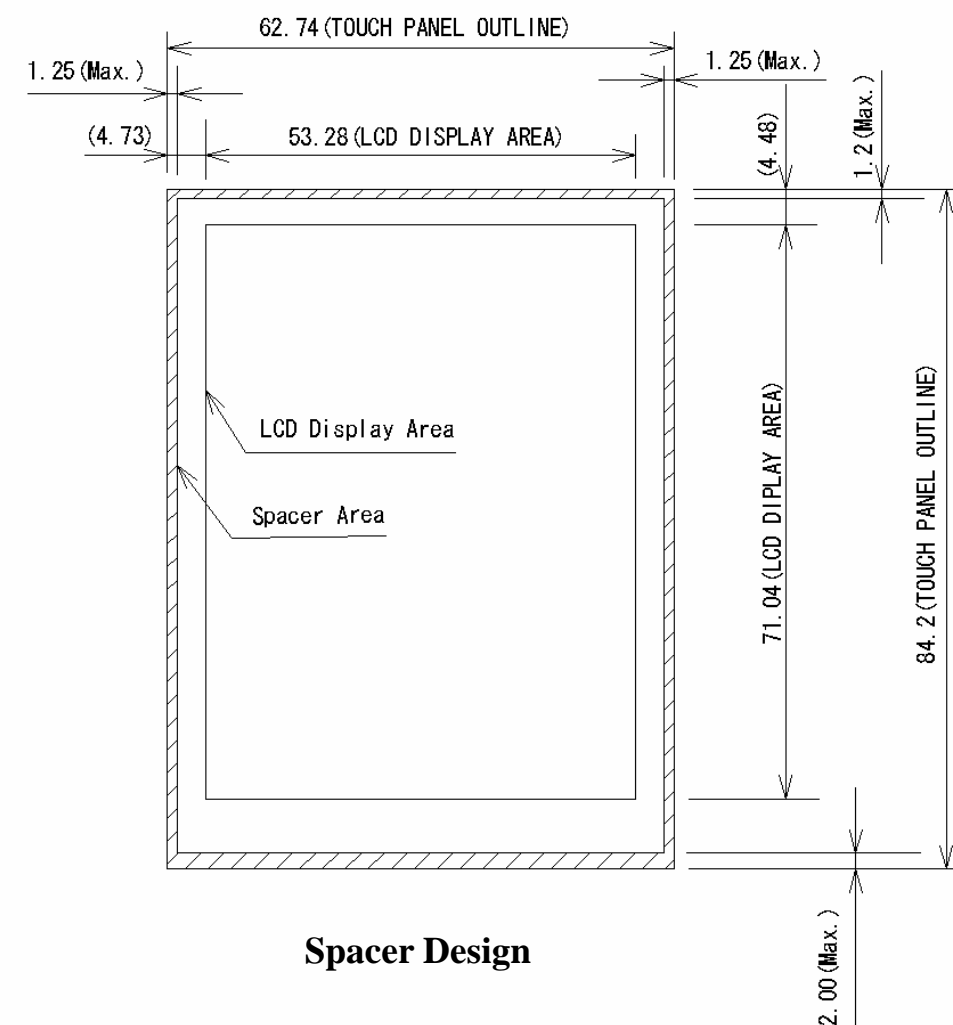





Spacer Design

Unit: mm

# PRELIMINARY

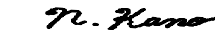
## REVISION HISTORY

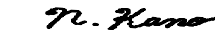
*The inside of latest specifications is revised to the clerical error and the major improvement of previous edition. Only a changed part such as functions, characteristic value and so on that may affect a design of customers, are described especially below.*

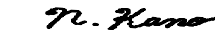
Edition	Document number	Prepared date	Revision contents and signature									
1st edition	DOD-PP-0144	Jan. 18, 2007	<p><b>Revision contents</b></p> <p>New issue</p> <p><b>Signature of writer</b></p> <table data-bbox="544 701 1433 842"><tr><td data-bbox="544 701 842 734"><i>Approved by</i></td><td data-bbox="842 701 1157 734"><i>Checked by</i></td><td data-bbox="1157 701 1433 734"><i>Prepared by</i></td></tr><tr><td data-bbox="544 757 842 801"></td><td data-bbox="842 757 1157 801">_____</td><td data-bbox="1157 757 1433 801"></td></tr><tr><td data-bbox="544 801 842 842">T. OGAWA</td><td data-bbox="842 801 1157 842">_____</td><td data-bbox="1157 801 1433 842">N. KANO</td></tr></table>	<i>Approved by</i>	<i>Checked by</i>	<i>Prepared by</i>		_____		T. OGAWA	_____	N. KANO
<i>Approved by</i>	<i>Checked by</i>	<i>Prepared by</i>										
	_____											
T. OGAWA	_____	N. KANO										