

**PRELIMINARY**

**NLT Technologies, Ltd.**

# **TFT COLOR LCD MODULE**

**NL8048AC19-13**

**18cm (7.0 Type)**

**WVGA**

**LVDS interface (1port)**

## **PRELIMINARY DATA SHEET**

**DOD-PP-1763 (3rd edition)**

**This PRELIMINARY DATA SHEET is updated document from DOD-PP-1687(2)**

**All information is subject to change without notice. Please confirm the sales representative before starting to design your system.**

# PRELIMINARY

## INTRODUCTION

The Copyright to this document belongs to NLT Technologies, Ltd. (hereinafter called "NLT"). No part of this document will be used, reproduced or copied without prior written consent of NLT.

NLT does and will not assume any liability for infringement of patents, copyrights or other intellectual property rights of any third party arising out of or in connection with application of the products described herein except for that directly attributable to mechanisms and workmanship thereof. No license, express or implied, is granted under any patent, copyright or other intellectual property right of NLT.

Some electronic products would fail or malfunction at a certain rate. In spite of every effort to enhance reliability of products by NLT, the possibility of failures and malfunction might not be avoided entirely. To prevent the risks of damage to death, human bodily injury or other property arising out thereof or in connection therewith, each customer is required to take sufficient measures in its safety designs and plans including, but not limited to, redundant system, fire-containment and anti-failure.

The products are classified into three grades: "**Standard**", "**Special**", and "**Specific**". Each quality grade is designed for applications described below. Any customer who intends to use a product for application other than that of Standard is required to contact an NLT sales representative in advance.

**The Standard:** Applications as any failure, malfunction or error of the products are free from any damage to death, human bodily injury or other property (Products Safety Issue) and not related the safety of the public (Social Issues), like general electric devices.

Examples: Office equipment, audio and visual equipment, communication equipment, test and measurement equipment, personal electronic equipment, home electronic appliances, car navigation system (with no vehicle control functions), seat entertainment monitor for vehicles and airplanes, fish finder (except marine radar integrated type), PDA, etc.

**The Special:** Applications as any failure, malfunction or error of the products might directly cause any damage to death, human bodily injury or other property (Products Safety Issue) and the safety of the public (Social Issues) and required high level reliability by conventional wisdom.

Examples: Vehicle/train/ship control system, traffic signals system, traffic information control system, air traffic control system, surgery/operation equipment monitor, disaster/crime prevention system, etc.

**The Specific:** Applications as any failure, malfunction or error of the products might severe cause any damage to death, human bodily injury or other property (Products Safety Issue) and the safety of the public (Social Issues) and developed, designed and manufactured in accordance with the standards or quality assurance program designated by the customer who requires extremely high level reliability and quality.

Examples: Aerospace system (except seat entertainment monitor), nuclear control system, life support system, etc.

The quality grade of this product is the "**Standard**" unless otherwise specified in this document.

# PRELIMINARY

## CONTENTS

|   |           |
|---|-----------|
| <b>INTRODUCTION</b> .....                                       | <b>2</b>  |
| <b>1. OUTLINE</b> .....   | <b>4</b>  |
| 1.1 STRUCTURE AND PRINCIPLE .....                               | 4         |
| 1.2 APPLICATION .....   | 4         |
| 1.3 FEATURES .....  | 4         |
| <b>2. GENERAL SPECIFICATIONS</b> .....                          | <b>5</b>  |
| <b>3. BLOCK DIAGRAM</b> .....                                   | <b>6</b>  |
| <b>4. DETAILED SPECIFICATIONS</b> .....                         | <b>7</b>  |
| 4.1 MECHANICAL SPECIFICATIONS .....                             | 7         |
| 4.2 ABSOLUTE MAXIMUM RATINGS.....                               | 7         |
| 4.3 ELECTRICAL CHARACTERISTICS.....                             | 8         |
| 4.3.1 LCD panel signal processing board .....                   | 8         |
| 4.3.2 LED driver.....   | 8         |
| 4.3.3 Power supply voltage ripple.....                          | 9         |
| 4.3.4 Fuse.....   | 9         |
| 4.4 POWER SUPPLY VOLTAGE SEQUENCE .....                         | 10        |
| 4.4.1 LCD panel signal processing board .....                   | 10        |
| 4.4.2 LED driver .....  | 10        |
| 4.5 CONNECTIONS AND FUNCTIONS FOR INTERFACE PINS .....          | 11        |
| 4.5.1 LCD panel signal processing board .....                   | 11        |
| 4.5.2 LED driver.....   | 12        |
| 4.5.3 Positions of plug and socket .....                        | 12        |
| 4.5.4 Connection between receiver and transmitter for LVDS..... | 13        |
| 4.5.5 Input data mapping .....                                  | 14        |
| 4.6 DISPLAY COLORS AND INPUT DATA SIGNALS.....                  | 14        |
| 4.7 DISPLAY POSITIONS .....                                     | 15        |
| 4.8 SCANNING DIRECTIONS .....                                   | 15        |
| 4.9 INPUT SIGNAL TIMINGS .....                                  | 16        |
| 4.9.1 Outline of input signal timings .....                     | 16        |
| 4.9.2 Timing characteristics.....                               | 17        |
| 4.9.3 Input signal timing chart.....                            | 18        |
| 4.10 OPTICS.....  | 19        |
| 4.10.1 Optical characteristics.....                             | 19        |
| 4.10.2 Definition of contrast ratio.....                        | 20        |
| 4.10.3 Definition of luminance uniformity.....                  | 20        |
| 4.10.4 Definition of response times .....                       | 20        |
| 4.10.5 Definition of viewing angles.....                        | 20        |
| <b>5. ESTIMATED LUMINANCE LIFETIME</b> .....                    | <b>21</b> |
| <b>6. RELIABILITY TESTS</b> .....                               | <b>22</b> |
| <b>7. PRECAUTIONS</b> .....                                     | <b>23</b> |
| 7.1 MEANING OF CAUTION SIGNS .....                              | 23        |
| 7.2 CAUTIONS .....  | 23        |
| 7.3 ATTENTIONS.....   | 23        |
| 7.3.1 Handling of the product .....                             | 23        |
| 7.3.2 Environment.....  | 24        |
| 7.3.3 Characteristics.....                                      | 24        |
| 7.3.4 Others.....   | 24        |
| <b>8. OUTLINE DRAWINGS</b> .....                                | <b>25</b> |
| 8.1 FRONT VIEW .....  | 25        |
| 8.2 REAR VIEW .....   | 26        |
| <b>REVISION HISTORY</b> .....                                   | <b>27</b> |

### 1. OUTLINE

#### 1.1 STRUCTURE AND PRINCIPLE

Color LCD module NL8048AC19-13 is composed of the amorphous silicon thin film transistor liquid crystal display (a-Si TFT LCD) panel structure with driver LSIs for driving the TFT (Thin Film Transistor) array and a backlight.

The a-Si TFT LCD panel structure is injected liquid crystal material into a narrow gap between the TFT array glass substrate and a color-filter glass substrate.

Color (Red, Green, Blue) data signals from a host system (e.g. signal generator, etc.) are modulated into best form for active matrix system by a signal processing circuit, and sent to the driver LSIs which drive the individual TFT arrays.

The TFT array as an electro-optical switch regulates the amount of transmitted light from the backlight assembly, when it is controlled by data signals. Color images are created by regulating the amount of transmitted light through the TFT array of red, green and blue dots.

#### 1.2 APPLICATION

- For industrial use

#### 1.3 FEATURES

- High luminance
- High contrast
- Wide viewing angle
- LVDS interface
- Reversible-scan direction
- LED backlight
- Built in LED driver

# PRELIMINARY

NLT Technologies, Ltd.

NL8048AC19-13

## 2. GENERAL SPECIFICATIONS

|                                   |  |
|-----------------------------------|--|
| <b>Display area</b>               | 152.4 (H) × 91.44 (V) mm   |
| <b>Diagonal size of display</b>   | 18cm (7.0 inches)  |
| <b>Drive system</b>               | a-Si TFT active matrix   |
| <b>Display color</b>              | 262,144 colors   |
| <b>Pixel</b>                      | 800 (H) × 480 (V) pixels   |
| <b>Pixel arrangement</b>          | RGB (Red dot, Green dot, Blue dot) vertical stripe   |
| <b>Dot pitch</b>                  | 0.0635 (H) × 0.1905 (V) mm   |
| <b>Pixel pitch</b>                | 0.1905 (H) × 0.1905 (V) mm   |
| <b>Module size</b>                | 170.0 (H) × 111.0 (V) × 8.5 (D) mm (typ.)  |
| <b>Weight</b>                     | TBD g (typ.)   |
| <b>Contrast ratio</b>             | (800):1 (typ.)   |
| <b>Viewing angle</b>              | At the contrast ratio $\geq 10:1$<br><ul style="list-style-type: none"> <li>• Horizontal: Right side 70° (typ.), Left side 70° (typ.)</li> <li>• Vertical: Up side 70° (typ.), Down side 60° (typ.)</li> </ul>   |
| <b>Designed viewing direction</b> | At DPS= Low or Open: Normal scan<br><ul style="list-style-type: none"> <li>• Viewing direction without image reversal: Up side (12 o'clock)</li> <li>• Viewing direction with contrast peak: Down side (6 o'clock)</li> <li>• Viewing angle with optimum grayscale (<math>\gamma \approx 2.2</math>): Normal axis (perpendicular)</li> </ul> |
| <b>Polarizer surface</b>          | Clear  |
| <b>Polarizer pencil-hardness</b>  | 3H (min.) [by JIS K5600]   |
| <b>Color gamut</b>                | At LCD panel center<br>60 % (typ.) [against NTSC color space]  |
| <b>Response time</b>              | $T_{on} + T_{off}$ (10% $\leftrightarrow$ 90%)<br>(18) ms (typ.)   |
| <b>Luminance</b>                  | At the maximum luminance control<br>500 cd/m <sup>2</sup> (typ.)   |
| <b>Signal system</b>              | LVDS interface (1port)<br>(Receiver: TBD)<br>6bit digital signals for data of RGB colors, Dot clock (CLK),<br>Data enable (DE)   |
| <b>Power supply voltage</b>       | LCD panel signal processing board: 3.3V<br>LED driver: 12V   |
| <b>Backlight</b>                  | LED backlight built in LED driver  |
| <b>Power consumption</b>          | At the maximum luminance control, Checkered flag pattern<br>TBD W (typ.)   |

3

### 3. BLOCK DIAGRAM

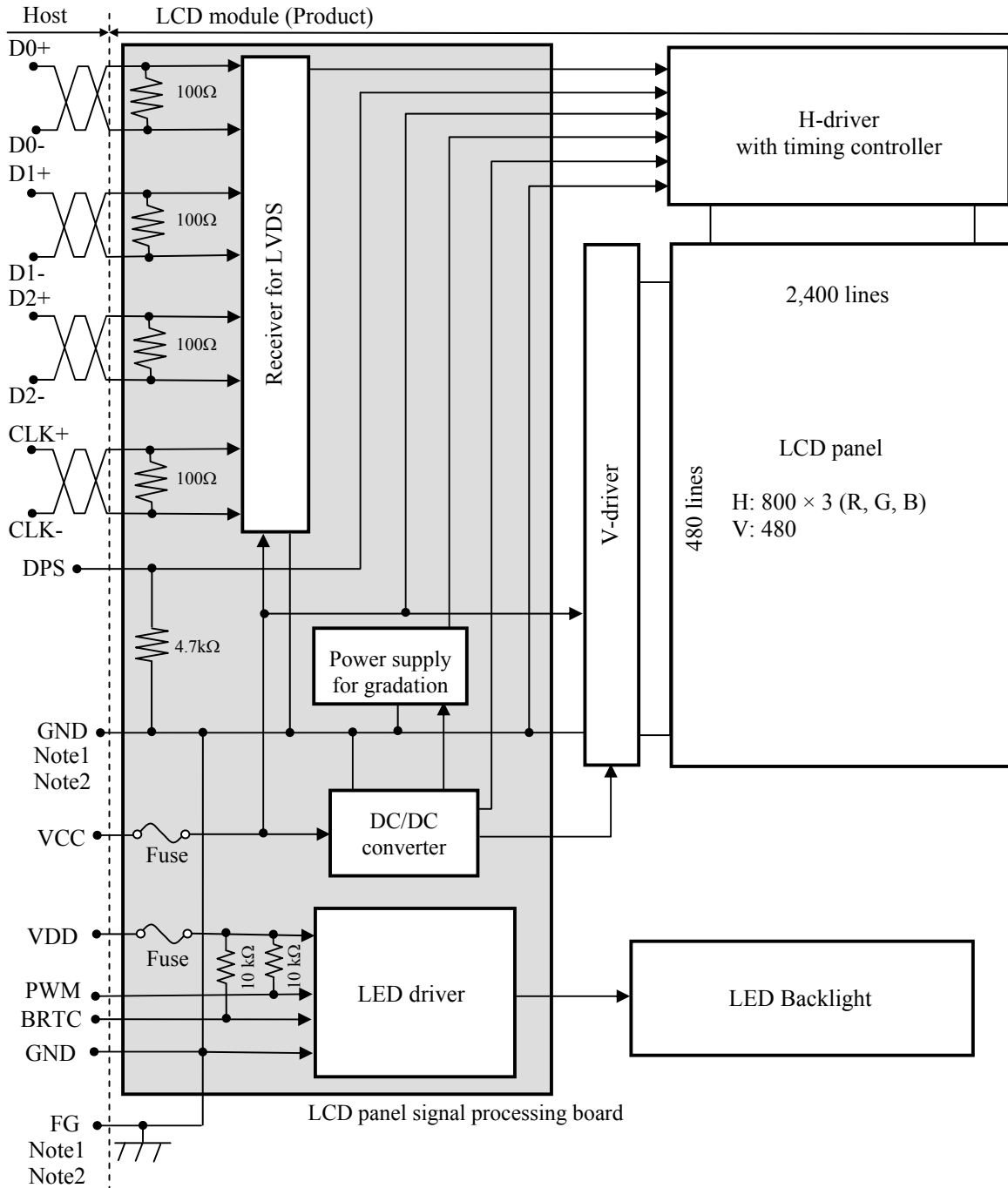

3

Note1: Relations between GND (Signal ground and LED driver ground) and FG (Frame ground) in the LCD module are as follows.

|          |           |
|----------|-----------|
| GND - FG | Connected |
|----------|-----------|

Note2: GND and FG must be connected to customer equipment's ground, and it is recommended that these grounds be connected together in customer equipment.

# PRELIMINARY

NLT Technologies, Ltd.

NL8048AC19-13

## 4. DETAILED SPECIFICATIONS

### 4.1 MECHANICAL SPECIFICATIONS

| Parameter    | Specification   | Unit |
|--------------|---|------|
| Module size  | 170.0 ± 0.5 (W) × 111.0 ± 0.5 (H) × 8.5 ± 0.5 (D) Note1 | mm   |
| Display area | 152.4 (H) × 91.44 (V) Note1                             | mm   |
| Weight       | TBD (typ.), TBD (max.)                                  | g    |

Note1: See "8. OUTLINE DRAWINGS".

### 4.2 ABSOLUTE MAXIMUM RATINGS

| Parameter                 |                                   | Symbol        | Rating          | Unit             | Remarks        |       |
|---------------------------|-----------------------------------|---------------|-----------------|------------------|----------------|-------|
| Power supply voltage      | LCD panel signal processing board | VCC           | -0.3 to +(4.0)  | V                | Ta = 25°C      |       |
|                           | LED driver                        | VDD           | -0.3 to +(15)   |                  |                |       |
| Input voltage for signals | Display signals Note1             | VD            | -0.3 to VCC+0.3 | V                |                |       |
|                           | Function signals Note2            | VF            |                 | V                |                |       |
|                           | Function signal for LED driver    | PWM           | -0.3 to +(15)   | V                |                |       |
| BRTC                      |                                   | -0.3 to +(15) | V               |                  |                |       |
| Storage temperature       |                                   | Tst           | -30 to +80      | °C               |                | -     |
| Operating temperature     | Front surface                     | TopF          | -30 to +80      | °C               |                | Note3 |
|                           | Rear surface                      | TopR          | -30 to +80      | °C               | Note4          |       |
| Relative humidity Note5   |                                   | RH            | ≤ 95            | %                | Ta ≤ 40°C      |       |
|                           |                                   |               | ≤ 85            | %                | 40 < Ta ≤ 50°C |       |
|                           |                                   |               | ≤ 55            | %                | 50 < Ta ≤ 60°C |       |
|                           |                                   |               | ≤ 36            | %                | 60 < Ta ≤ 70°C |       |
|                           |                                   |               | ≤ 24            | %                | 70 < Ta ≤ 80°C |       |
| Absolute humidity Note5   |                                   | AH            | ≤ 70            | g/m <sup>3</sup> | Ta > 70°C      |       |

Note1: D0+/-, D1+/-, D2+/- and CLK+/-

Note2: DPS

Note3: Measured at LCD panel surface (including self-heat)

Note4: Measured at LCD module's rear shield surface (including self-heat)

Note5: No condensation.

# PRELIMINARY

## 4.3 ELECTRICAL CHARACTERISTICS

### 4.3.1 LCD panel signal processing board

(Ta= 25°C)

| Parameter                            | Symbol | min. | typ.           | max.           | Unit   | Remarks      |                        |
|--------------------------------------|--------|------|----------------|----------------|--------|--------------|------------------------|
| Power supply voltage                 | VCC    | 3.0  | 3.3            | 3.6            | V      | -            |                        |
| Power supply current                 | ICC    | -    | (160)<br>Note1 | (250)<br>Note2 | mA     | at VCC= 3.3V |                        |
| Permissible ripple voltage           | VRPC   | -    | -              | 100            | mVp-p  | for VCC      |                        |
| Differential input threshold voltage | High   | VTH  | -              | -              | +100   | mV           | at VCM= 1.2 V<br>Note3 |
|                                      | Low    | VTL  | -100           | -              | -      | mV           |                        |
| Terminating resistance               | RT     | -    | 100            | -              | Ω      | -            |                        |
| Input voltage for DPS signals        | High   | VFH  | 0.7VCC         | -              | VCC    | V            | CMOS level             |
|                                      | Low    | VFL  | 0              | -              | 0.3VCC | V            |                        |
| Input current for DPS signal         | High   | IFH  | -              | -              | (-300) | μA           | -                      |
|                                      | Low    | IFL  | (-300)         | -              | -      | μA           |                        |

3

Note1: Checkered flag pattern [by EIAJ ED-2522]

Note2: Pattern for maximum current

Note3: Common mode voltage for LVDS receiver

### 4.3.2 LED driver

(Ta= 25°C)

| Parameter                     | Symbol            | min.  | typ.  | max.         | Unit  | Remarks      |   |
|-------------------------------|-------------------|-------|-------|--------------|-------|--------------|---|
| Power supply voltage          | VDD               | 10.8  | 12.0  | 13.2         | V     | Note1        |   |
| Power supply current<br>Note2 | IDD               | -     | TBD   | TBD<br>Note3 | mA    | Note4        |   |
| Permissible ripple voltage    | VRPD              | -     | -     | 200          | mVp-p | for VDD      |   |
| Input voltage for PWM signal  | High              | VDFH1 | (2.1) | -            | VDD   | V            | - |
|                               | Low               | VDFL1 | -     | -            | (0.8) | V            |   |
| Input voltage for BRTC signal | High              | VDFH2 | (2.1) | -            | VDD   | V            | - |
|                               | Low               | VDFL2 | -     | -            | (0.8) | V            |   |
| PWM frequency                 | f <sub>PWM</sub>  | 100   | -     | (1k)         | Hz    | Note5, Note6 |   |
| PWM duty cycle                | DR <sub>PWM</sub> | (1)   | -     | 100          | %     | Note7        |   |
| PWM pulse width               | t <sub>PWH</sub>  | TBD   | -     | -            | μs    |              |   |

Note1: When designing of the power supply, take the measures for the prevention of surge voltage.

Note2: The power supply lines (VDD and GND) may have ripple voltage during luminance control of LED. There is the possibility that the ripple voltage produces acoustic noise and signal wave noise in audio circuit and so on. Put a capacitor between the power supply lines (VDD and GND) to reduce the noise if necessary.

Note3: This value excludes peak current such as overshoot current.



# PRELIMINARY

Note4: At the maximum luminance control.

Note5: A recommended  $f_{PWM}$  value is as follows.

$$f_{PWM} = \frac{2n-1}{4} \times fv$$

(n = integer, fv = frame frequency of LCD module)

Note6: Depending on the frequency used, a noise may appear on the screen, please conduct a thorough evaluation.

Note7: While the BRTC signal is high, do not set the tPWH (PWM pulse width) is less than (TBD $\mu$ s). It may cause abnormal working of the backlight. In this case, turn the backlight off and then on again by BRTC signal.

### 4.3.3 Power supply voltage ripple

This product works, even if the ripple voltage levels are over the permissible values as the following table, but there might be noise on the display image.

| Power supply voltage |       | Ripple voltage<br>(Measure at input terminal of power supply) | Note1 | Unit  |
|----------------------|-------|---|-------|-------|
| VCC                  | 3.3V  | $\leq 100$  |       | mVp-p |
| VDD                  | 12.0V | $\leq 200$  |       | mVp-p |

Note1: The permissible ripple voltage includes spike noise.

### 4.3.4 Fuse

| Parameter | Fuse       |                         | Rating | Fusing current | Remarks |
|-----------|------------|-------------------------|--------|----------------|---------|
|           | Type       | Supplier                |        |                |         |
| VCC       | FCC16152AB | KAMAYA ELECTRIC CO.,LTD | 1.5A   | 3.0A           | Note1   |
|           |            |                         | 36V    |                |         |
| VDD       | FCC16152AB | KAMAYA ELECTRIC CO.,LTD | 1.5A   | 3.0A           |         |
|           |            |                         | 36V    |                |         |

Note1: The power supply's rated current must be more than the fusing current. If it is less than the fusing current, the fuse may not blow in a short time, and then nasty smell, smoke and so on may occur.

3

### 4.4 POWER SUPPLY VOLTAGE SEQUENCE

#### 4.4.1 LCD panel signal processing board

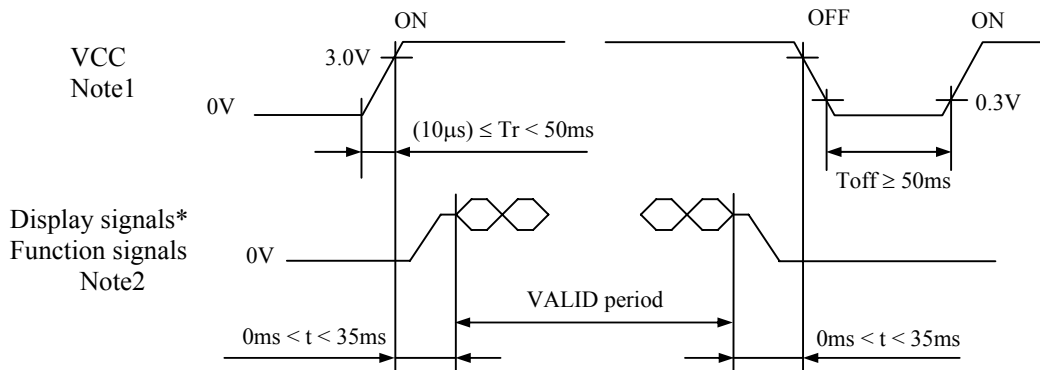

\* These signals should be measured at the terminal of 100Ω resistance.

Note1: If there is a voltage variation (voltage drop) at the rising edge of VCC below 3.0V, there is a possibility that a product does not work due to a protection circuit.

Note2: Display signals (D0+/-, D1+/-, D2+/- and CLK+/-) and function signals (DPS) must be set to Low or High-impedance, except the VALID period (See above sequence diagram), in order to avoid the circuitry damage.

If some of display and function signals of this product are cut while this product is working, even if the signal input to it once again, it might not work normally. If a customer stops the display and function signals, VCC also must be shut down.

#### 4.4.2 LED driver

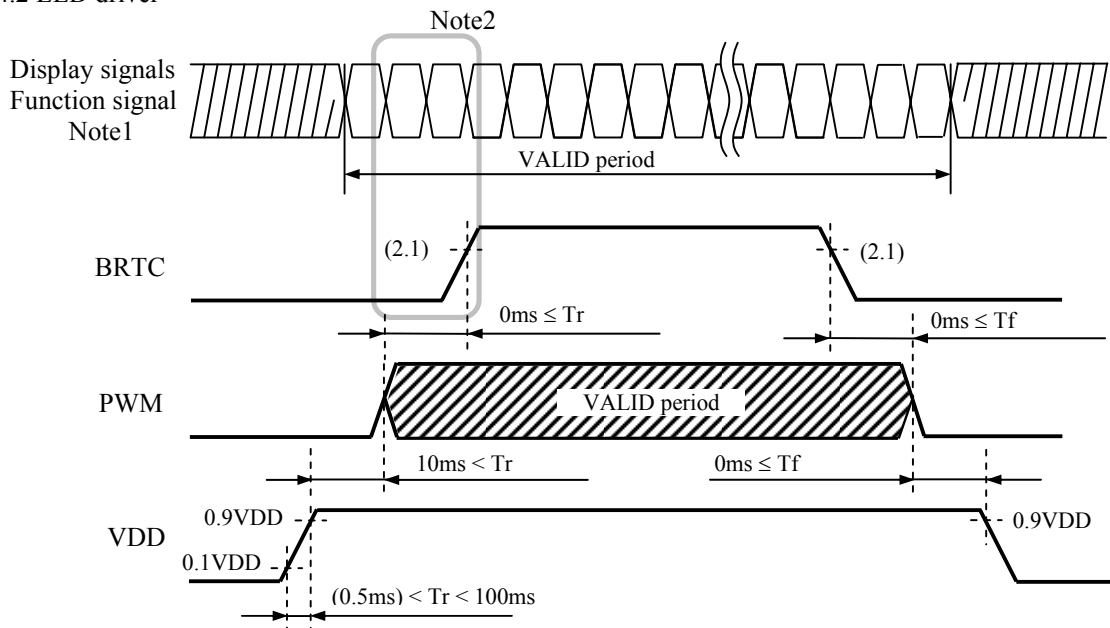

Note1: These are the display and function signals for LCD panel signal processing board.

Note2: The backlight should be turned on within the valid period of display and function signals, in order to avoid unstable data display.

# PRELIMINARY

## 4.5 CONNECTIONS AND FUNCTIONS FOR INTERFACE PINS

### 4.5.1 LCD panel signal processing board

CN1 socket (LCD module side): FI-SE20P-HFE (Japan Aviation Electronics Industry Limited (JAE))  
 Adaptable plug: FI-S20S (Japan Aviation Electronics Industry Limited (JAE))

| Pin No. | Symbol | Signal                      | Remarks  |
|---------|--------|-----------------------------|--|
| 1       | GND    | Ground                      | Note4  |
| 2       | GND    |                             |  |
| 3       | DPS    | Selection of scan direction | High : Reverse scan<br>Low or Open : Normal scan Note2 |
| 4       | N.C.   | -                           | Keep this pin Open.                                    |
| 5       | GND    | Ground                      | Note4  |
| 6       | CLK+   | Pixel clock                 | Note3  |
| 7       | CLK-   |                             |  |
| 8       | GND    | Ground                      | Note4  |
| 9       | D2+    | Pixel data (B2-B5,DE)       | Note1, Note3   |
| 10      | D2-    |                             |  |
| 11      | GND    | Ground                      | Note4  |
| 12      | D1+    | Pixel data (G1-G5,B0-B1)    | Note1, Note3   |
| 13      | D1-    |                             |  |
| 14      | GND    | Ground                      | Note4  |
| 15      | D0+    | Pixel data (R0-R5,G0)       | Note1, Note3   |
| 16      | D0-    |                             |  |
| 17      | GND    | Ground                      | Note4  |
| 18      | GND    |                             |  |
| 19      | VCC    | Power supply                | Note4  |
| 20      | VCC    |                             |  |

Note1: See "4.6 DISPLAY COLORS AND INPUT DATA SIGNALS".

Note2: See "4.8 SCANNING DIRECTIONS".

Note3: Twist pair wires with 100Ω (Characteristic impedance) should be used between LCD panel signal processing board and LVDS transmitter.

Note4: All GND and VCC terminals should be used without any non-connected lines.

# PRELIMINARY

## 4.5.2 LED driver

CN2 socket (LCD module side): FI-S6P-HFE (Japan Aviation Electronics Industry Limited (JAE))  
Adaptable plug: FI-S6S (Japan Aviation Electronics Industry Limited (JAE))

| Pin No. | Symbol | Function                                  | Remarks  |
|---------|--------|---|--|
| 1       | VDD    | Power supply                              | Note1  |
| 2       | VDD    | Power supply                              |  |
| 3       | GND    | Ground                                    |  |
| 4       | GND    | Ground                                    |  |
| 5       | BRTC   | Backlight ON/OFF control                  | High or Open: Backlight ON<br>Low: Backlight OFF |
| 6       | PWM    | Luminance control terminal by PWM Dimming | High or Open: 100% (Max. Luminance)              |

Note1: All GND and VDD terminals must be connected to appropriate terminals.

## 4.5.3 Positions of plug and socket

Rear side

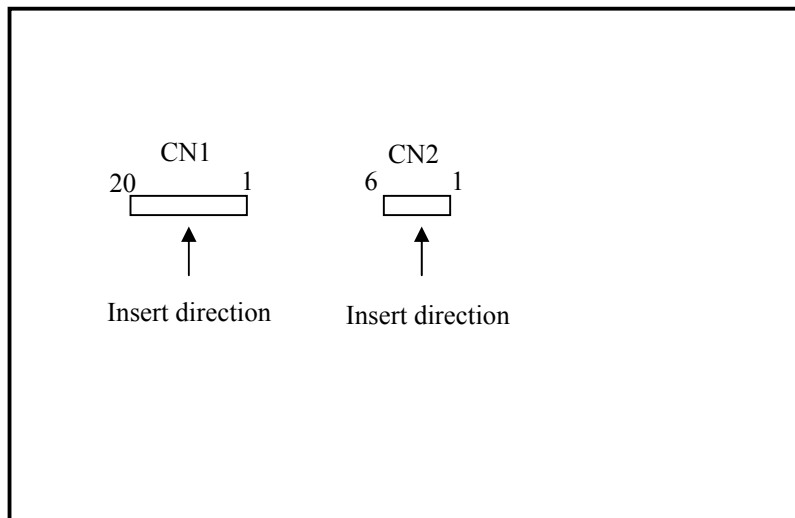

# PRELIMINARY

## 4.5.4 Connection between receiver and transmitter for LVDS

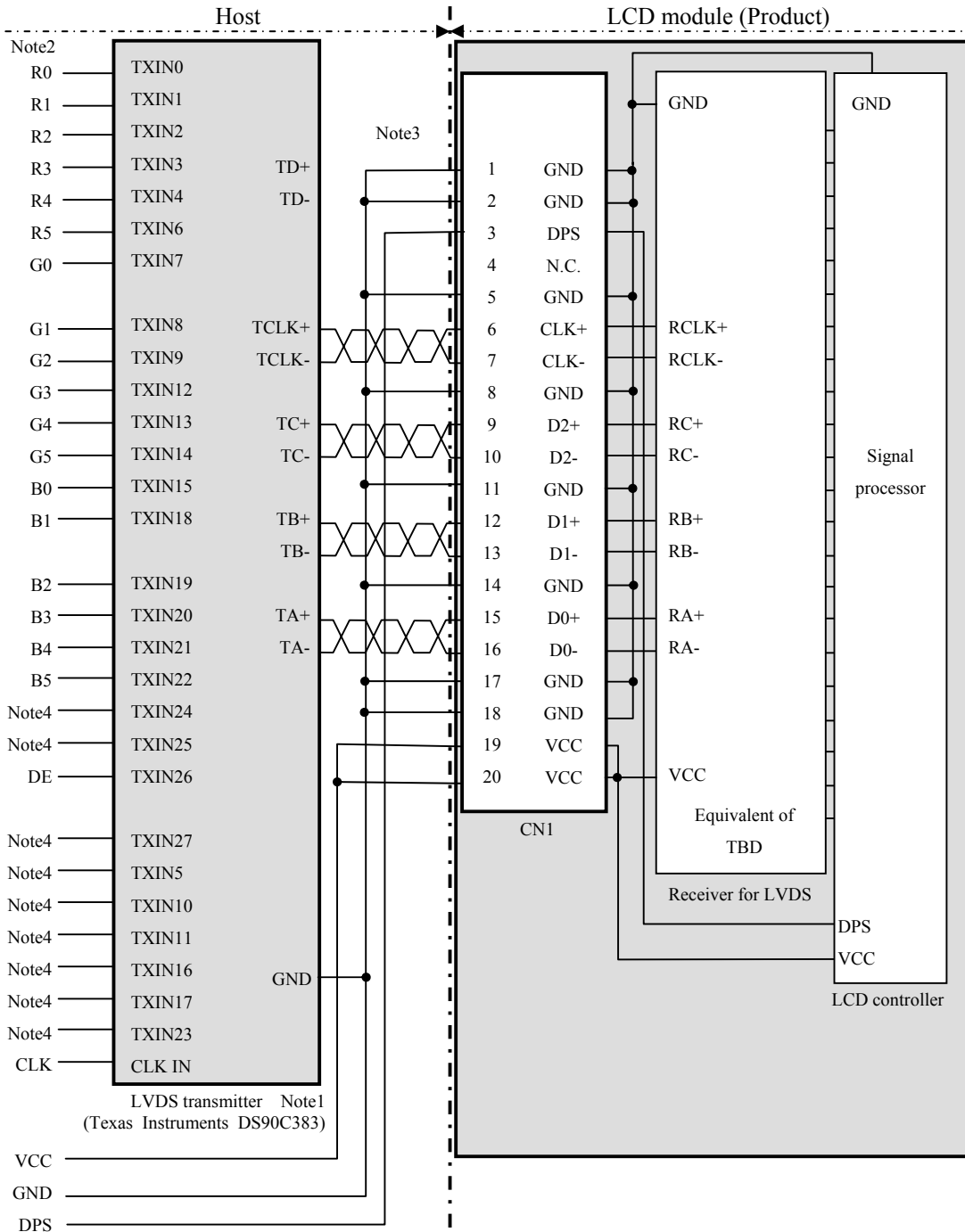

- Note1: Recommended transmitter: DS90C383 (Texas Instruments) or equivalent
- Note2: LSB (Least Significant Bit) – R0, G0, B0 MSB (Most Significant Bit) – R5, G5, B5
- Note3: Twist pair wires with 100Ω (Characteristic impedance) should be used between LCD panel signal processing board and LVDS transmitter.
- Note4: Input signals to TXIN24, TXIN25, TXIN27, TXIN5, TXIN10, TXIN11, TXIN16, TXIN17 and TXIN23 are not used inside the product, but do not keep these terminals open to avoid noise problem.

# PRELIMINARY

## 4.5.5 Input data mapping

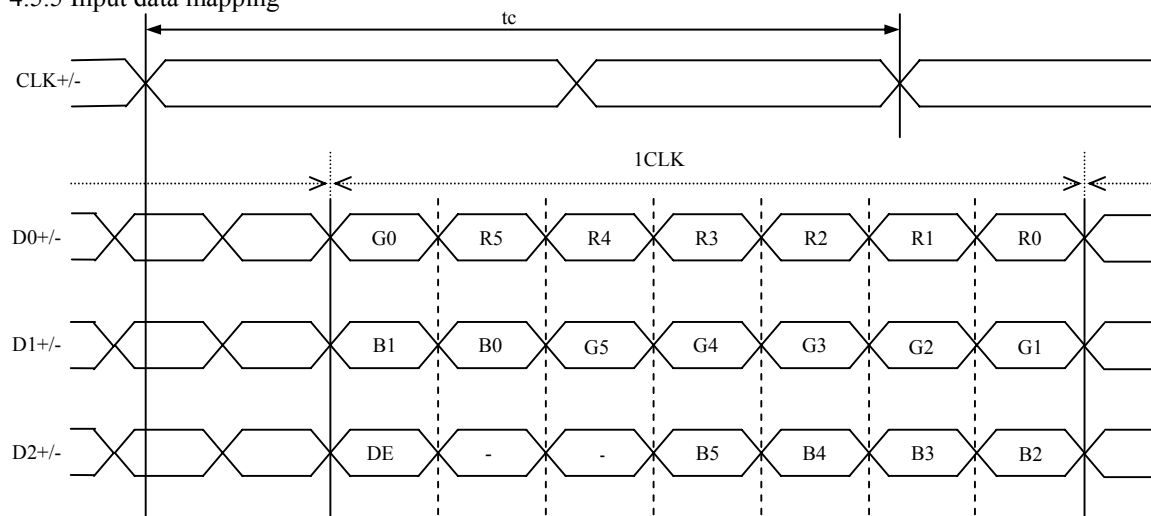

## 4.6 DISPLAY COLORS AND INPUT DATA SIGNALS

This product can display 262,144 colors with 64 gray scales. Also the relation between display colors and input data signals is as follows.

| Display colors   |         | Data signal (0: Low level, 1: High level) |    |    |    |    |    |    |    |    |    |    |    |    |    |    |    |    |    |
|------------------|---------|---|----|----|----|----|----|----|----|----|----|----|----|----|----|----|----|----|----|
|                  |         | R5  | R4 | R3 | R2 | R1 | R0 | G5 | G4 | G3 | G2 | G1 | G0 | B5 | B4 | B3 | B2 | B1 | B0 |
| Basic colors     | Black   | 0   | 0  | 0  | 0  | 0  | 0  | 0  | 0  | 0  | 0  | 0  | 0  | 0  | 0  | 0  | 0  | 0  | 0  |
|                  | Blue    | 0   | 0  | 0  | 0  | 0  | 0  | 0  | 0  | 0  | 0  | 0  | 0  | 1  | 1  | 1  | 1  | 1  | 1  |
|                  | Red     | 1   | 1  | 1  | 1  | 1  | 1  | 0  | 0  | 0  | 0  | 0  | 0  | 0  | 0  | 0  | 0  | 0  | 0  |
|                  | Magenta | 1   | 1  | 1  | 1  | 1  | 1  | 0  | 0  | 0  | 0  | 0  | 0  | 1  | 1  | 1  | 1  | 1  | 1  |
|                  | Green   | 0   | 0  | 0  | 0  | 0  | 0  | 1  | 1  | 1  | 1  | 1  | 1  | 0  | 0  | 0  | 0  | 0  | 0  |
|                  | Cyan    | 0   | 0  | 0  | 0  | 0  | 0  | 1  | 1  | 1  | 1  | 1  | 1  | 1  | 1  | 1  | 1  | 1  | 1  |
|                  | Yellow  | 1   | 1  | 1  | 1  | 1  | 1  | 1  | 1  | 1  | 1  | 1  | 1  | 0  | 0  | 0  | 0  | 0  | 0  |
|                  | White   | 1   | 1  | 1  | 1  | 1  | 1  | 1  | 1  | 1  | 1  | 1  | 1  | 1  | 1  | 1  | 1  | 1  | 1  |
| Red gray scale   | Black   | 0   | 0  | 0  | 0  | 0  | 0  | 0  | 0  | 0  | 0  | 0  | 0  | 0  | 0  | 0  | 0  | 0  | 0  |
|                  | dark    | 0   | 0  | 0  | 0  | 0  | 1  | 0  | 0  | 0  | 0  | 0  | 0  | 0  | 0  | 0  | 0  | 0  | 0  |
|                  | ↑       |   |    |    | ⋮  |    |    |    |    |    |    |    |    |    |    |    |    |    |    |
|                  | ↓       |   |    |    | ⋮  |    |    |    |    |    |    |    |    |    |    |    |    |    |    |
|                  | bright  | 1   | 1  | 1  | 1  | 0  | 1  | 0  | 0  | 0  | 0  | 0  | 0  | 0  | 0  | 0  | 0  | 0  | 0  |
|                  | Red     | 1   | 1  | 1  | 1  | 1  | 0  | 0  | 0  | 0  | 0  | 0  | 0  | 0  | 0  | 0  | 0  | 0  | 0  |
| Green gray scale | Black   | 0   | 0  | 0  | 0  | 0  | 0  | 0  | 0  | 0  | 0  | 0  | 0  | 0  | 0  | 0  | 0  | 0  | 0  |
|                  | dark    | 0   | 0  | 0  | 0  | 0  | 0  | 0  | 0  | 0  | 0  | 1  | 0  | 0  | 0  | 0  | 0  | 0  | 0  |
|                  | ↑       |   |    |    | ⋮  |    |    |    |    |    |    |    |    |    |    |    |    |    |    |
|                  | ↓       |   |    |    | ⋮  |    |    |    |    |    |    |    |    |    |    |    |    |    |    |
|                  | bright  | 0   | 0  | 0  | 0  | 0  | 0  | 1  | 1  | 1  | 1  | 0  | 1  | 0  | 0  | 0  | 0  | 0  | 0  |
|                  | Green   | 0   | 0  | 0  | 0  | 0  | 0  | 1  | 1  | 1  | 1  | 1  | 0  | 0  | 0  | 0  | 0  | 0  | 0  |
| Blue gray scale  | Black   | 0   | 0  | 0  | 0  | 0  | 0  | 0  | 0  | 0  | 0  | 0  | 0  | 0  | 0  | 0  | 0  | 0  | 0  |
|                  | dark    | 0   | 0  | 0  | 0  | 0  | 0  | 0  | 0  | 0  | 0  | 0  | 0  | 0  | 0  | 0  | 0  | 1  | 0  |
|                  | ↑       |   |    |    | ⋮  |    |    |    |    |    |    |    |    |    |    |    |    |    |    |
|                  | ↓       |   |    |    | ⋮  |    |    |    |    |    |    |    |    |    |    |    |    |    |    |
|                  | bright  | 0   | 0  | 0  | 0  | 0  | 0  | 0  | 0  | 0  | 0  | 0  | 0  | 1  | 1  | 1  | 1  | 0  | 1  |
|                  | Blue    | 0   | 0  | 0  | 0  | 0  | 0  | 0  | 0  | 0  | 0  | 0  | 0  | 1  | 1  | 1  | 1  | 1  | 1  |

# PRELIMINARY

## 4.7 DISPLAY POSITIONS

The following table is the coordinates per pixel (See "4.8 SCANNING DIRECTIONS").

|            |            |     |            |     |             |             |
|------------|------------|-----|------------|-----|-------------|-------------|
| C (0, 0)   |            |     |            |     |             |             |
| R          | G          | B   |            |     |             |             |
| ↑          |            |     |            |     |             |             |
| C( 0, 0)   | C( 1, 0)   | ... | C( X, 0)   | ... | C(798, 0)   | C(799, 0)   |
| C( 0, 1)   | C( 1, 1)   | ... | C( X, 1)   | ... | C(798, 1)   | C(799, 1)   |
| .          | .          | .   | .          | .   | .           | .           |
| .          | .          | ... | .          | ... | .           | ...         |
| .          | .          | .   | .          | .   | .           | .           |
| C( 0, Y)   | C( 1, Y)   | ... | C( X, Y)   | ... | C(798, Y)   | C(799, Y)   |
| .          | .          | .   | .          | .   | .           | .           |
| .          | .          | ... | .          | ... | .           | .           |
| .          | .          | .   | .          | .   | .           | .           |
| C( 0, 478) | C( 1, 478) | ... | C( X, 478) | ... | C(798, 478) | C(799, 478) |
| C( 0, 479) | C( 1, 479) | ... | C( X, 479) | ... | C(798, 479) | C(799, 479) |

## 4.8 SCANNING DIRECTIONS

The following figures are seen from a front view.

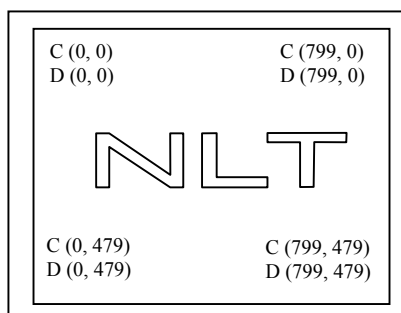

Note1

Figure1. Normal scan (DPS:Low or Open)

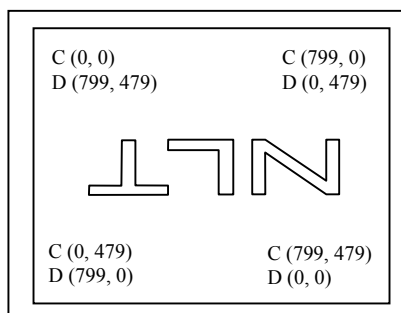

Note1

Figure2. Reverse scan (DPS: High)

Note1: Meaning of C (X, Y) and D (X, Y)

C (X, Y): The coordinates of the display position (See "4.7 DISPLAY POSITIONS").

D (X, Y): The data number of input signal for LCD panel signal processing board

### 4.9 INPUT SIGNAL TIMINGS

#### 4.9.1 Outline of input signal timings

- Horizontal signal

Note1

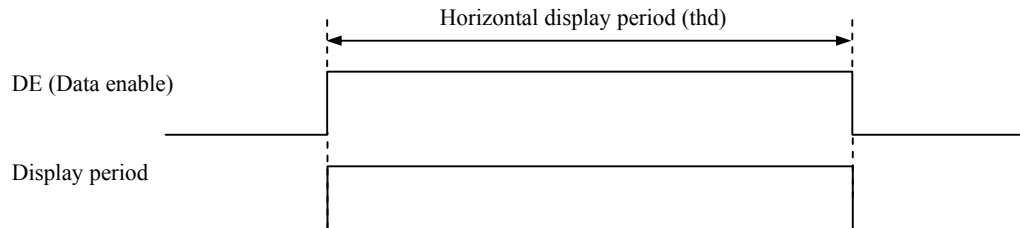

- Vertical signal

Note1

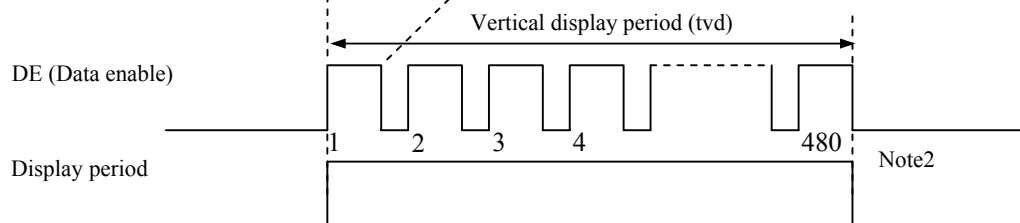

Note1: This diagram indicates virtual signal for set up to timing.

Note2: See "4.9.3 Input signal timing chart" for the pulse number.



# PRELIMINARY

4.9.2 Timing characteristics

(Note1, Note2, Note3)

| Parameter |                         | Symbol         | min. | typ.   | max.   | Unit  | Remarks         |                 |
|-----------|-------------------------|----------------|------|--------|--------|-------|-----------------|-----------------|
| CLK       | Frequency               | 1/tc           | 28.0 | 32.256 | 36.0   | MHz   | 31.002ns (typ.) |                 |
|           | Duty                    | -              | -    |        |        | -     | -               |                 |
|           | Rise time, Fall time    | -              |      |        |        | ns    |                 |                 |
| DATA      | CLK-DATA                | Setup time     | -    |        |        | ns    | -               |                 |
|           |                         | Hold time      |      |        |        | ns    |                 |                 |
|           | Rise time, Fall time    | -              |      |        |        | ns    |                 |                 |
| DE        | Horizontal              | Cycle          | th   | 28.44  | 31.746 | 36.57 | μs              | 31.5 kHz (typ.) |
|           |                         |                |      | -      | 1,024  | -     | CLK             |                 |
|           |                         | Display period | thd  | 800    |        |       | CLK             | -               |
|           | Vertical<br>(One frame) | Cycle          | tv   | 14.931 | 16.667 | 19.19 | ms              | 60.0 Hz (typ.)  |
|           |                         |                |      | -      | 525    | -     | H               |                 |
|           |                         | Display period | tvd  | 480    |        |       | H               |                 |
|           | CLK-DE                  | Setup time     | -    | -      |        |       | ns              | -               |
| Hold time |                         | -              | ns   |        |        |       |                 |                 |
|           | Rise time, Fall time    | -              | ns   |        |        |       |                 |                 |

Note1: Definition of parameters is as follows.

$$t_c = 1\text{CLK}, t_h = 1H$$

Note2: See the data sheet of LVDS transmitter.

Note3: Vertical cycle (tv) should be specified in integral multiple of Horizontal cycle (th).

### 4.9.3 Input signal timing chart

#### Horizontal timing

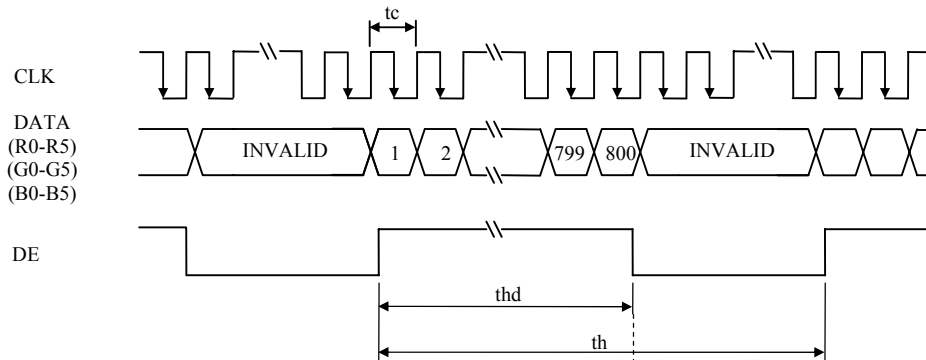

#### Vertical timing

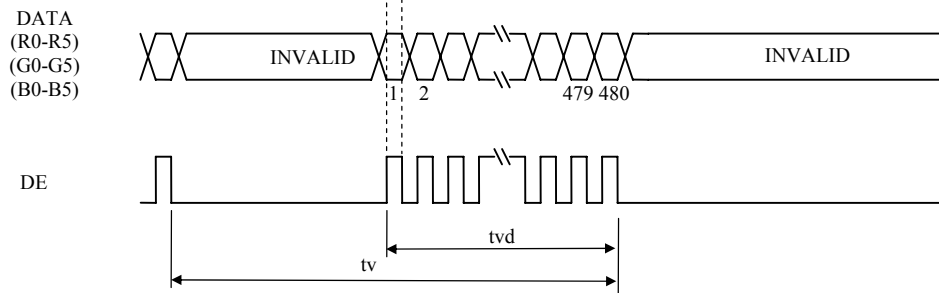

### 4.10 OPTICS

#### 4.10.1 Optical characteristics

(Note1, Note2)

| Parameter            | Condition   | Symbol   | min.       | typ.   | max.  | Unit              | Measuring instrument | Remarks        |       |
|----------------------|---|--|------------|--------|-------|-------------------|----------------------|----------------|-------|
| Luminance            | White at center<br>$\theta R=0^\circ, \theta L=0^\circ, \theta U=0^\circ, \theta D=0^\circ$                     | L  | 300        | 500    | -     | cd/m <sup>2</sup> | BM-5A                | -              |       |
| Contrast ratio       | White/Black at center<br>$\theta R=0^\circ, \theta L=0^\circ, \theta U=0^\circ, \theta D=0^\circ$               | CR   | (500)      | (800)  | -     | -                 | BM-5A                | Note3          |       |
| Luminance uniformity | White<br>$\theta R=0^\circ, \theta L=0^\circ, \theta U=0^\circ, \theta D=0^\circ$                               | LU   | -          | (1.25) | (1.4) | -                 | BM-5A                | Note4          |       |
| Chromaticity         | White   | x coordinate                                     | Wx         | 0.263  | 0.313 | 0.363             | -                    | SR-3           | Note5 |
|                      |   | y coordinate                                     | Wy         | 0.279  | 0.329 | 0.379             | -                    |                |       |
|                      | Red   | x coordinate                                     | Rx         | -      | TBD   | -                 | -                    |                |       |
|                      |   | y coordinate                                     | Ry         | -      | TBD   | -                 | -                    |                |       |
|                      | Green   | x coordinate                                     | Gx         | -      | TBD   | -                 | -                    |                |       |
|                      |   | y coordinate                                     | Gy         | -      | TBD   | -                 | -                    |                |       |
| Blue                 | x coordinate  | Bx   | -          | TBD    | -     | -                 |                      |                |       |
|                      | y coordinate  | By   | -          | TBD    | -     | -                 |                      |                |       |
| Color gamut          | $\theta R=0^\circ, \theta L=0^\circ, \theta U=0^\circ, \theta D=0^\circ$<br>at center, against NTSC color space | C  | 55         | 60     | -     | %                 |                      |                |       |
| Response time        | White to Black  | Ton  | -          | TBD    | TBD   | ms                | BM-5A<br>-10000      | Note6<br>Note7 |       |
|                      | Black to White  | Toff   | -          | TBD    | TBD   | ms                |                      |                |       |
|                      | Ton + Toff  | -  | -          | (18)   | TBD   | ms                |                      |                |       |
| Viewing angle        | Right   | $\theta U=0^\circ, \theta D=0^\circ, CR \geq 10$ | $\theta R$ | TBD    | 70    | -                 | EZ<br>Contrast       | Note8          |       |
|                      | Left  | $\theta U=0^\circ, \theta D=0^\circ, CR \geq 10$ | $\theta L$ | TBD    | 70    | -                 |                      |                |       |
|                      | Up  | $\theta R=0^\circ, \theta L=0^\circ, CR \geq 10$ | $\theta U$ | TBD    | 70    | -                 |                      |                |       |
|                      | Down  | $\theta R=0^\circ, \theta L=0^\circ, CR \geq 10$ | $\theta D$ | TBD    | 60    | -                 |                      |                |       |

Note1: These are initial characteristics.

Note2: Measurement conditions are as follows.

$T_a = 25^\circ\text{C}$ ,  $V_{CC} = 3.3\text{V}$ ,  $V_{DD} = 12.0\text{V}$ , PWM: Duty 100%,

Display mode: WVGA, Horizontal cycle = 1/31.5kHz, Vertical cycle = 1/60.0Hz,

DPS= Low or Open: Normal scan

Optical characteristics are measured at luminance saturation 20minutes after the product works, in the dark room. Also measurement methods are as follows.

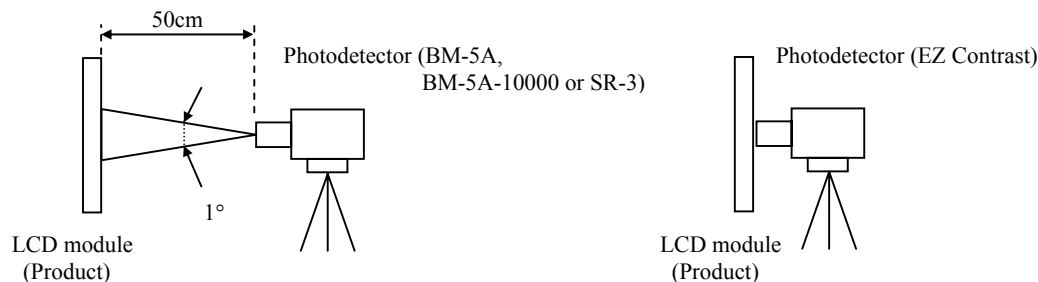

Note3: See "4.10.2 Definition of contrast ratio".

Note4: See "4.10.3 Definition of luminance uniformity".

Note5: These coordinates are found on CIE 1931 chromaticity diagram.

Note6: Product surface temperature:  $T_{opF} = \text{TBD}^\circ\text{C}$

Note7: See "4.10.4 Definition of response times".

Note8: See "4.10.5 Definition of viewing angles".

### 4.10.2 Definition of contrast ratio

The contrast ratio is calculated by using the following formula.

$$\text{Contrast ratio (CR)} = \frac{\text{Luminance of white screen}}{\text{Luminance of black screen}}$$

### 4.10.3 Definition of luminance uniformity

The luminance uniformity is calculated by using following formula.

$$\text{Luminance uniformity (LU)} = \frac{\text{Maximum luminance from ① to ⑤}}{\text{Minimum luminance from ① to ⑤}}$$

The luminance is measured at near the 5 points shown below.

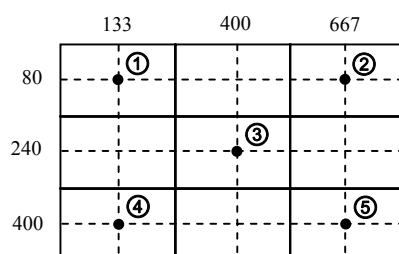

### 4.10.4 Definition of response times

Response time is measured at the time when the luminance changes from "white" to "black", or "black" to "white" on the same screen point, by photo-detector. Ton is the time when the luminance changes from 90% down to 10%. Also Toff is the time when the luminance changes from 10% up to 90% (See the following diagram.).

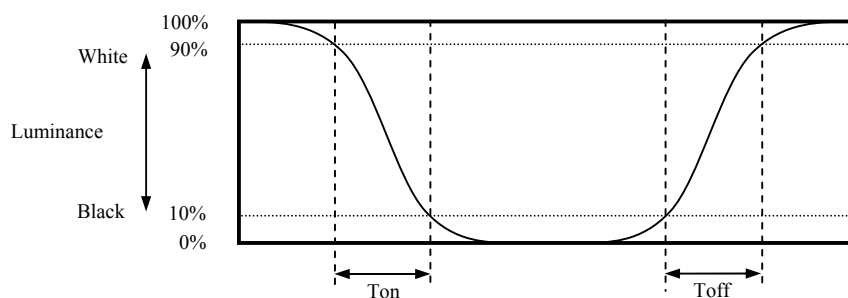

### 4.10.5 Definition of viewing angles

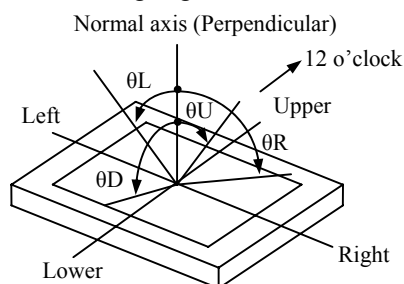

# PRELIMINARY

## 5. ESTIMATED LUMINANCE LIFETIME

The luminance lifetime is the time from initial luminance to half-luminance.

**This lifetime is the estimated value, and is not guarantee value.**

| Condition                |   | Estimated luminance lifetime<br>(Life time expectancy)<br>Note1, Note2, Note3 | Unit |
|--------------------------|---|---|------|
| LED elementary substance | 25°C (Ambient temperature of the product)<br>Continuous operation, PWM Duty :100% | 100,000   | h    |

Note1: Life time expectancy is mean time to half-luminance.

Note2: Estimated luminance lifetime is not the value for LCD module but the value for LED elementary substance.

Note3: By ambient temperature, the lifetime changes particularly. Especially, in case the product works under high temperature environment, the lifetime becomes short.

# PRELIMINARY

## 6. RELIABILITY TESTS

| Test item                                    | Condition   | Judgment                | Note1 |
|--|---|-------------------------|-------|
| High temperature and humidity<br>(Operation) | ① $60 \pm 2^\circ\text{C}$ , RH= 90%, 240hours<br>② Display data is black.  | No display malfunctions |       |
| High temperature<br>(Operation)              | ① $80 \pm 3^\circ\text{C}$ , 240hours<br>② Display data is black.   |                         |       |
| Heat cycle<br>(Operation)                    | ① $-30 \pm 3^\circ\text{C}$ ...1hour<br>$80 \pm 3^\circ\text{C}$ ...1hour<br>② 50cycles, 4 hours/cycle<br>③ Display data is black.                                  |                         |       |
| Thermal shock<br>(Non operation)             | ① $-30 \pm 3^\circ\text{C}$ ...30minutes<br>$80 \pm 3^\circ\text{C}$ ...30minutes<br>② 100cycles, 1hour/cycle<br>③ Temperature transition time is within 5 minutes. |                         |       |
| ESD<br>(Operation)                           | Contact Discharge<br>① 150pF, 150Ω, $\pm 10\text{kV}$<br>② 9 places on a panel surface Note2<br>③ 10 times each places at 1 sec interval                            |                         |       |
| Dust<br>(Operation)                          | ① Sample dust: No. 15 (by JIS-Z8901)<br>② 15 seconds stir<br>③ 8 times repeat at 1 hour interval  |                         |       |
| Vibration<br>(Non operation)                 | ① 5 to 100Hz, $19.6\text{m/s}^2$<br>② 1 minute/cycle<br>③ X, Y, Z directions<br>④ 120 times each directions   |                         |       |
| Mechanical shock<br>(Non operation)          | ① $539\text{m/s}^2$ , 11ms<br>② X, Y, Z directions<br>③ 5 times each directions   |                         |       |

Note1: Display and appearance are checked under environmental conditions equivalent to the inspection conditions of defect criteria.

Note2: See the following figure for discharge points.

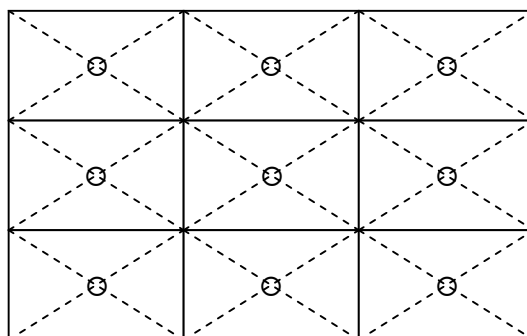

## 7. PRECAUTIONS

### 7.1 MEANING OF CAUTION SIGNS

The following caution signs have very important meaning. **Be sure to read "7.2 CAUTIONS" and "7.3 ATTENTIONS"!**



This sign has the meaning that a customer will be injured or the product will sustain damage if the customer practices wrong operations.



This sign has the meaning that a customer will be injured if the customer practices wrong operations.

### 7.2 CAUTIONS



**\* Do not shock and press the LCD panel and the backlight! There is a danger of breaking, because they are made of glass. (Shock: Equal to or no greater than 539m/s<sup>2</sup> and equal to or no greater than 11ms, Pressure: Equal to or no greater than 19.6 N (φ16mm jig))**



### 7.3 ATTENTIONS

#### 7.3.1 Handling of the product

- ① Take hold of both ends without touching the circuit board when the product (LCD module) is picked up from inner packing box to avoid broken down or misadjustment, because of stress to mounting parts on the circuit board.
- ② When the product is put on the table temporarily, display surface must be placed downward.
- ③ When handling the product, take the measures of electrostatic discharge with such as earth band, ionic shower and so on, because the product may be damaged by electrostatic.
- ④ The torque for product mounting screws must never exceed 0.23 N·m. Higher torque might result in distortion of the bezel. And the length of product mounting screws must be ≤ 2.0 mm.
- ⑤ The product must be installed using mounting holes without undue stress such as bends or twist (See outline drawings). And do not add undue stress to any portion (such as bezel flat area). Bends or twist described above and undue stress to any portion may cause display mura.
- ⑥ Do not press or rub on the sensitive product surface. When cleaning the panel surface, wipe it with a soft dry cloth.
- ⑦ Do not push or pull the interface connectors while the product is working.
- ⑧ When handling the product, use of an original protection sheet on the product surface (polarizer) is recommended for protection of product surface. Adhesive type protection sheet may change color or characteristics of the polarizer.
- ⑨ Usually liquid crystals don't leak through the breakage of glasses because of the surface tension of thin layer and the construction of LCD panel. But, if you contact with liquid crystal by any chance, please wash it away with soap and water.

### 7.3.2 Environment

- ① Do not operate or store in high temperature, high humidity, dewdrop atmosphere or corrosive gases. Keep the product in packing box with antistatic pouch in room temperature to avoid dusts and sunlight, when storing the product.
- ② In order to prevent dew condensation occurred by temperature difference, the product packing box must be opened after enough time being left under the environment of an unpacking room. Evaluate the storage time sufficiently because dew condensation is affected by the environmental temperature and humidity. (Recommended leaving time: 6 hours or more with the original packing state after a customer receives the package)
- ③ Do not operate in high magnetic field. If not, circuit boards may be broken.
- ④ This product is not designed as radiation hardened.

### 7.3.3 Characteristics

**The following items are neither defects nor failures.**

- ① Characteristics of the LCD (such as response time, luminance, color uniformity and so on) may be changed depending on ambient temperature. If the product is stored under condition of low temperature for a long time, it may cause display mura. In this case, the product should be operated after enough time being left under condition of operating temperature.
- ② Display mura, flickering, vertical streams or tiny spots may be observed depending on display patterns.
- ③ Do not display the fixed pattern for a long time because it may cause image sticking. Use a screen saver, if the fixed pattern is displayed on the screen.
- ④ The display color may be changed depending on viewing angle because of the use of condenser sheet in the backlight.
- ⑤ Optical characteristics may be changed depending on input signal timings.

### 7.3.4 Others

- ① All GND, VCC and VDD terminals should be used without any non-connected lines.
- ② Do not disassemble a product or adjust variable resistors.
- ③ Pack the product with the original shipping package, in order to avoid any damages during transportation, when returning the product to NLT.



# PRELIMINARY

## 8. OUTLINE DRAWINGS

### 8.1 FRONT VIEW

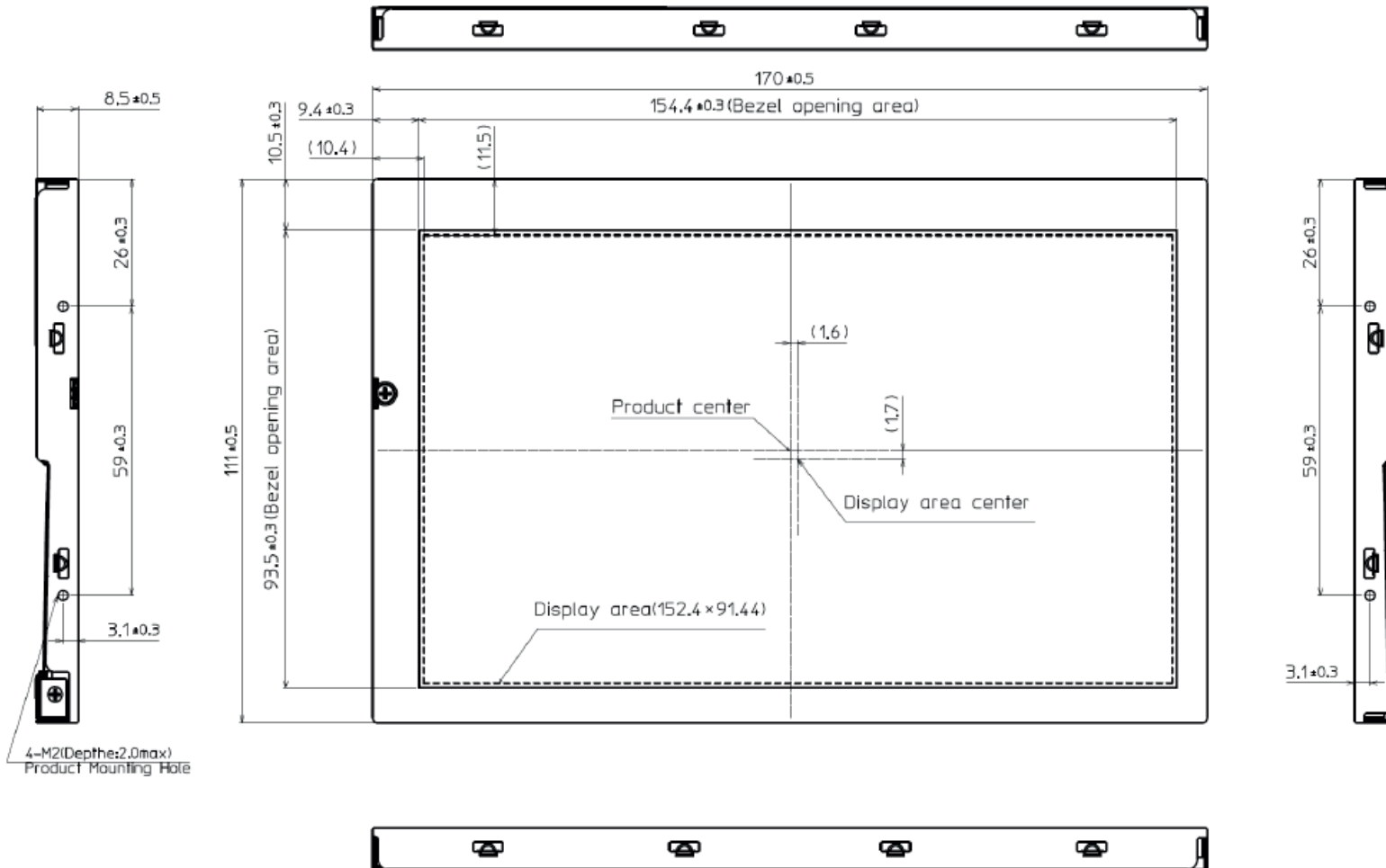

Note1: The values in parentheses are for reference.

Note2: The torque for product mounting screws must never exceed 0.23 N·m. And the length of product mounting screws must be  $\leq 2.0$  mm.

Unit: mm

8.2 REAR VIEW

3

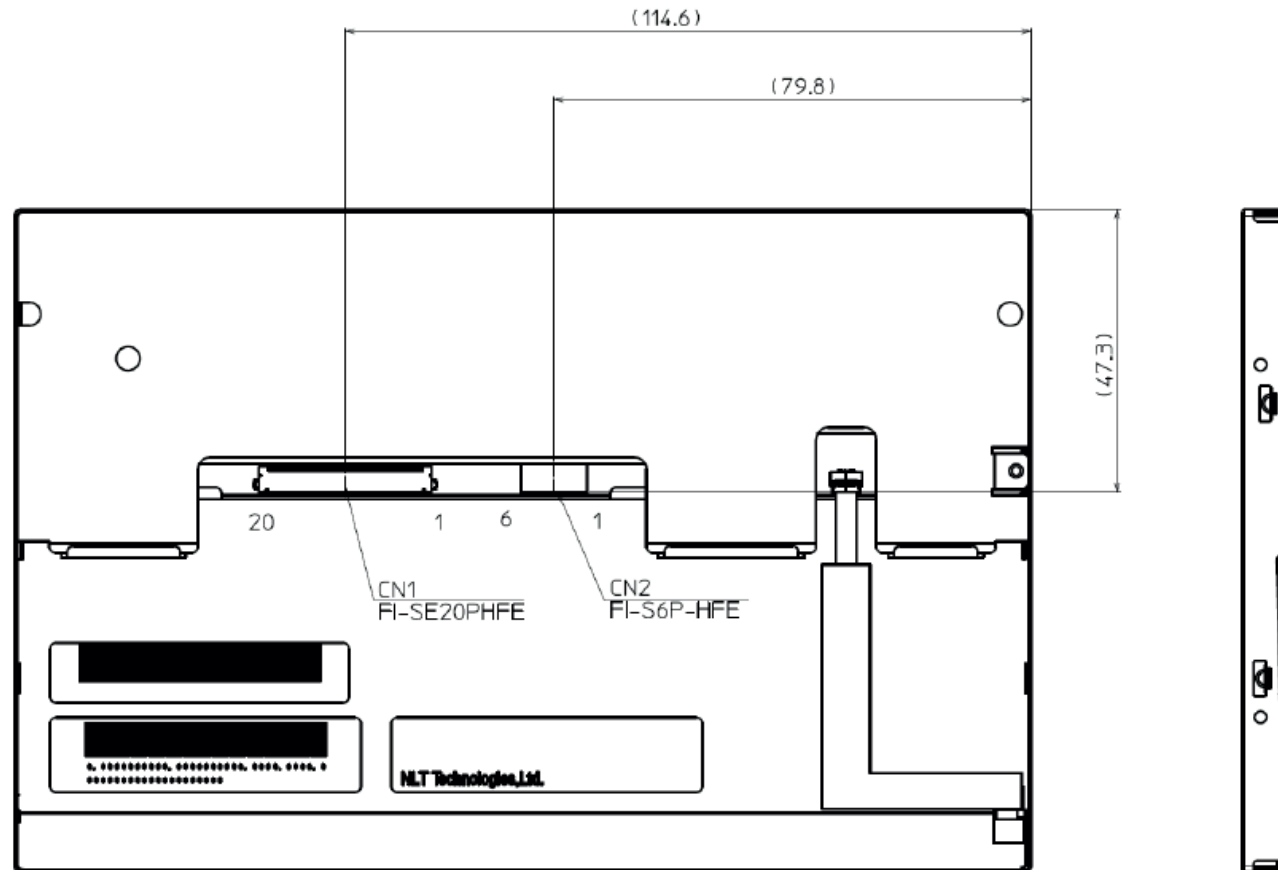



Note1: The values in parentheses are for reference.

Note2: The torque for product mounting screws must never exceed 0.23 N.m. And the length of product mounting screws must be  $\leq 2.0$  mm.

Unit: mm

REVISION HISTORY

The inside of latest specifications is revised to the clerical error and the major improvement of previous edition. Only a changed part such as functions, characteristic value and so on that may affect a design of customers, are described especially below.

| Edition     | Document number | Prepared date | Revision contents and signature  |
|-------------|-----------------|---------------|--|
| 1st edition | DOD-PP-1675     | May 31, 2013  | <p><b>Revision contents</b></p> <p>New issue</p> <p><b>Writer</b></p> <p>Approved by <u>R. KAWASHIMA</u>      Checked by _____      Prepared by <u>E. YOSHIMURA</u></p>  |
| 2nd edition | DOD-PP-1687     | Jun. 17, 2013 | <p><b>Revision contents</b></p> <p>CORRECTION OF DESCRIPTIVE CONTENTS</p> <p>P7 ABSOLUTE MAXIMUM RATINGS</p> <ul style="list-style-type: none"> <li>Power supply voltage - LED driver: -0.3 to +4.0 → -0.3 to +(4.0)</li> </ul> <p>P10 Power supply voltage sequence</p> <ul style="list-style-type: none"> <li>LCD panel: (0.5ms) ≤ Tr &lt; 50ms → (10μs) ≤ Tr &lt; 50ms</li> </ul> <p>P12 Backlight lamp</p> <ul style="list-style-type: none"> <li>Pin No.6 - Remarks: High or Open: 100% (Max. Luminance) (addition)</li> </ul> <p>P12 Positions of plug and socket (revised)</p> <p>P20 Definition of luminance uniformity</p> <ul style="list-style-type: none"> <li>⊙ → ⊕ (correction)</li> <li>Figure (Revised)</li> </ul> <p>P22 RELIABILITY TESTS</p> <ul style="list-style-type: none"> <li>ESD ①: ±15kV → ±10kV (correction)</li> </ul> <p><b>Writer</b></p> <p>Approved by <u>R. KAWASHIMA</u>      Checked by _____      Prepared by <u>E. YOSHIMURA</u></p>   |
| 3rd edition | DOD-PP-1763     | Sep. 30, 2013 | <p><b>Revision contents</b></p> <p>P5 General specifications</p> <ul style="list-style-type: none"> <li>Module size: (8.5) (D) mm (typ.) → 8.5 (D) mm (typ.)</li> </ul> <p>P6 Block diagram</p> <ul style="list-style-type: none"> <li>VDD – BRTC: TBD kΩ → 10 kΩ</li> <li>VDD – PWM: TBD kΩ → 10 kΩ</li> </ul> <p>P7 Mechanical specifications</p> <ul style="list-style-type: none"> <li>Module size: (8.5) ± 0.5 mm → 8.5 ± 0.5 mm</li> </ul> <p>P8 Electrical characteristics – LCD panel signal processing board</p> <ul style="list-style-type: none"> <li>Power supply current: TBD (typ., max.) mA → (160) (typ.), (250) (max.) mA</li> </ul> <p>P9 Fuse (Specified)</p> <p>P19 Optics – Optical characteristics</p> <ul style="list-style-type: none"> <li>Luminance: TBD (min.) cd/m<sup>2</sup> → 300 (min.) cd/m<sup>2</sup></li> <li>Contrast ratio: TBD (min.) → (500) (min.)</li> </ul> <p>P25 Outline drawing - Front view (Updated)</p> <p>P26 Outline drawing - Rear view (Specified)</p> <p><b>Signature of writer</b></p> <p>Approved by <u></u>      Checked by _____      Prepared by <u></u></p> <p><u>R. KAWASHIMA</u>      _____      <u>E. YOSHIMURA</u></p> |