

PRELIMINARY
NEC NEC LCD Technologies, Ltd.

TFT COLOR LCD MODULE

NL8060BC31-50F

**31cm (12.1 Type)
SVGA**

PRELIMINARY DATA SHEET

DOD-PP-0991 (1st edition)

**All information is subject to change without notice.
Please confirm the sales representative before
starting to design your system.**

PRELIMINARY

NEC NEC LCD Technologies, Ltd.

NL8060BC31-50F

INTRODUCTION

The Copyright to this document belongs to NEC LCD Technologies, Ltd. (hereinafter called "NEC"). No part of this document will be used, reproduced or copied without prior written consent of NEC.

NEC does and will not assume any liability for infringement of patents, copyrights or other intellectual property rights of any third party arising out of or in connection with application of the products described herein except for that directly attributable to mechanisms and workmanship thereof. No license, express or implied, is granted under any patent, copyright or other intellectual property right of NEC.

Some electronic parts/components would fail or malfunction at a certain rate. In spite of every effort to enhance reliability of products by NEC, the possibility of failures and malfunction might not be avoided entirely. To prevent the risks of damage to death, human bodily injury or other property arising out thereof or in connection therewith, each customer is required to take sufficient measures in its safety designs and plans including, but not limited to, redundant system, fire-containment and anti-failure.

The products are classified into three quality grades: "**Standard**", "**Special**", and "**Specific**" of the highest grade of a quality assurance program at the choice of a customer. Each quality grade is designed for applications described below. Any customer who intends to use a product for application other than that of Standard quality grade is required to contact an NEC sales representative in advance.

The **Standard** quality grade applies to the products developed, designed and manufactured in accordance with the NEC standard quality assurance program, which are designed for such application as any failure or malfunction of the products (sets) or parts/components incorporated therein a customer uses are, directly or indirectly, free of any damage to death, human bodily injury or other property, like general electronic devices.

Examples: Computers, office automation equipment, communications equipment, test and measurement equipment, audio and visual equipment, home electronic appliances, machine tools, personal electronic equipment, industrial robots, etc.

The **Special** quality grade applies to the products developed, designed and manufactured in accordance with an NEC quality assurance program stricter than the standard one, which are designed for such application as any failure or malfunction of the products (sets) or parts/components incorporated therein a customer uses might directly cause any damage to death, human bodily injury or other property, or such application under more severe condition than that defined in the Standard quality grade without such direct damage.

Examples: Control systems for transportation equipment (automobiles, trains, ships, etc.), traffic control systems, anti-disaster systems, anti-crime systems, medical equipment not specifically designed for life support, safety equipment, etc.

The **Specific** quality grade applies to the products developed, designed and manufactured in accordance with the standards or quality assurance program designated by a customer who requires an extremely higher level of reliability and quality for such products.

Examples: Military systems, aircraft control equipment, aerospace equipment, nuclear reactor control systems, medical equipment/devices/systems for life support, etc.

The quality grade of this product is the "**Standard**" unless otherwise specified in this document.

PRELIMINARY

NEC NEC LCD Technologies, Ltd.

NL8060BC31-50F

CONTENTS

INTRODUCTION	2
1. OUTLINE	4
1.1 STRUCTURE AND PRINCIPLE	4
1.2 APPLICATION	4
1.3 FEATURES	4
2. GENERAL SPECIFICATIONS	5
3. BLOCK DIAGRAM	6
4. DETAILED SPECIFICATIONS	8
4.1 MECHANICAL SPECIFICATIONS	8
4.2 ABSOLUTE MAXIMUM RATINGS	8
4.3 ELECTRICAL CHARACTERISTICS	9
4.3.1 LCD panel signal processing board	9
4.3.2 Backlight	10
4.3.3 Power supply voltage ripple	10
4.3.4 Fuse	10
4.4 POWER SUPPLY VOLTAGE SEQUENCE	11
4.4.1 LCD panel signal processing board	11
4.4.2 LED Driver board	11
4.5 CONNECTIONS AND FUNCTIONS FOR INTERFACE PINS	12
4.5.1 LCD panel signal processing board	12
4.5.2 Backlight lamp	13
4.5.3 Positions of plug and socket	13
4.6 DISPLAY COLORS AND INPUT DATA SIGNALS	14
4.7 DISPLAY POSITIONS	15
4.8 SCANNING DIRECTIONS	15
4.9 INPUT SIGNAL TIMINGS	16
4.9.1 Outline of input signal timings	16
4.9.2 Timing characteristics	17
4.9.3 Input signal timing chart	19
4.10 OPTICS	22
4.10.1 Optical characteristics	22
4.10.2 Definition of contrast ratio	23
4.10.3 Definition of luminance uniformity	23
4.10.4 Definition of response times	23
4.10.5 Definition of viewing angles	23
5. ESTIMATED LUMINANCE LIFETIME	24
6. RELIABILITY TESTS	25
7. PRECAUTIONS	26
7.1 MEANING OF CAUTION SIGNS	26
7.2 CAUTIONS	26
7.3 ATTENTIONS	26
7.3.1 Handling of the product	26
7.3.2 Environment	27
7.3.3 Characteristics	27
7.3.4 Other	27
8. OUTLINE DRAWINGS	28
8.1 FRONT VIEW	28
8.2 REAR VIEW	29
REVISION HISTORY	30

PRELIMINARY

NEC NEC LCD Technologies, Ltd.

NL8060BC31-50F

1. OUTLINE

1.1 STRUCTURE AND PRINCIPLE

Color LCD module NL8060BC31-50F are composed of the amorphous silicon thin film transistor liquid crystal display (a-Si TFT LCD) panel structure with driver LSIs for driving the TFT (Thin Film Transistor) array and a backlight.

The a-Si TFT LCD panel structure is injected liquid crystal material into a narrow gap between the TFT array glass substrate and a color-filter glass substrate.

Color (Red, Green, Blue) data signals from a host system (e.g. signal generator, etc.) are modulated into best form for active matrix system by a signal processing board, and sent to the driver LSIs which drive the individual TFT arrays.

The TFT array as an electro-optical switch regulates the amount of transmitted light from the backlight assembly, when it is controlled by data signals. Color images are created by regulating the amount of transmitted light through the TFT array of red, green and blue dots.

1.2 APPLICATION

- For industrial use

1.3 FEATURES

- Long life LED backlight type
- High luminance
- High contrast
- Wide viewing angle
- Wide temperature range
- 6-bit digital RGB signals
- Reversible-scan direction
- Replaceable lamp holder for backlight

PRELIMINARY

NEC NEC LCD Technologies, Ltd.

NL8060BC31-50F

2. GENERAL SPECIFICATIONS

Display area	246.0 (H) × 184.5 (V) mm						
Diagonal size of display	31cm (12.1 inches)						
Drive system	a-Si TFT active matrix						
Display color	262,144 colors						
Pixel	800 (H) × 600 (V) pixels						
Pixel arrangement	RGB (Red dot, Green dot, Blue dot) vertical stripe						
Dot pitch	0.1025 (H) × 0.3075 (V) mm						
Pixel pitch	0.3075 (H) × 0.3075 (V) mm						
Module size	260.5 (W) × 203.0 (H) × 8.7 (D) mm (typ.)						
Weight	490 g (typ.)						
Contrast ratio	800:1 (typ.)						
Viewing angle	At the contrast ratio $\geq 10:1$ <ul style="list-style-type: none"> • Horizontal: Right side 80° (typ.), Left side 80° (typ.) • Vertical: Up side 80° (typ.), Down side 80° (typ.) 						
Designed viewing direction	At DPS= Low or Open: Normal scan <ul style="list-style-type: none"> • Viewing direction without image reversal: Up side (12 o'clock) • Viewing direction with contrast peak: Down side (6 o'clock) • Viewing angle with optimum grayscale ($\gamma=2.2$): Normal axis (perpendicular) 						
Polarizer surface	Clear						
Polarizer pencil-hardness	3H (min.) [by JIS K5400]						
Color gamut	At LCD panel center 40 % (typ.) [against NTSC color space]						
Response time	$T_{on} + T_{off}$ (10% \leftrightarrow 90%) TBD ms (typ.)						
Luminance	At $I_L = 50$ mA/One circuit 800 cd/m ² (typ.)						
Signal system	6-bit digital signals for data of RGB colors, Dot clock (CLK), Data enable (DE), Horizontal synchronous signal (Hsync), Vertical synchronous signal (Vsync)						
Power supply voltage	LCD panel signal processing board: 3.3V or 5.0V						
Backlight	LED backlight type: <table style="margin-left: 20px; border-collapse: collapse;"> <tr> <td style="border-left: 1px solid black; border-right: 1px solid black; padding: 0 10px;">Replaceable part</td> <td rowspan="2" style="font-size: 2em; vertical-align: middle;">}</td> </tr> <tr> <td style="border-left: 1px solid black; border-right: 1px solid black; padding: 0 10px;">• Lamp holder set: Type No. TBD</td> </tr> <tr> <td style="border-left: 1px solid black; border-right: 1px solid black; padding: 0 10px;">Recommended LED driver board (Option)</td> <td rowspan="2" style="font-size: 2em; vertical-align: middle;">}</td> </tr> <tr> <td style="border-left: 1px solid black; border-right: 1px solid black; padding: 0 10px;">• LED driver board :Type No. TBD</td> </tr> </table>	Replaceable part	}	• Lamp holder set: Type No. TBD	Recommended LED driver board (Option)	}	• LED driver board :Type No. TBD
Replaceable part	}						
• Lamp holder set: Type No. TBD							
Recommended LED driver board (Option)	}						
• LED driver board :Type No. TBD							
Power consumption	At $I_L = 50$ mA/One circuit, Checkered flag pattern TBD W (typ.)						

PRELIMINARY

NEC LCD Technologies, Ltd.

NL8060BC31-50F

3. BLOCK DIAGRAM

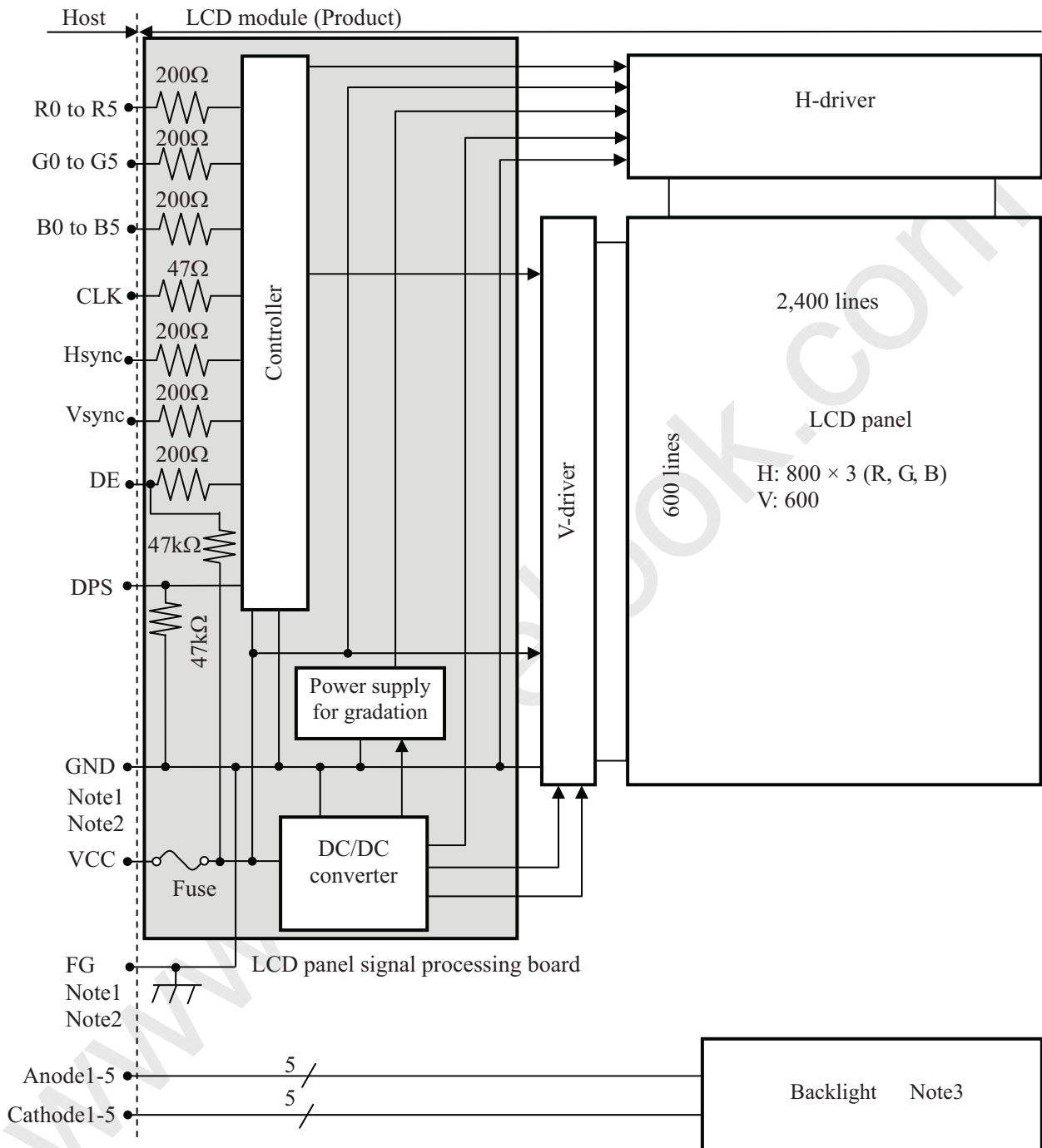

Note1: Relations between GND (Signal ground), FG (Frame ground) in the LCD module are as follows.

GND - FG	Connected
----------	-----------

Note2: GND, FG and GNDB must be connected to customer equipment's ground, and it is recommended that these grounds be connected together in customer equipment.

PRELIMINARY

NEC NEC LCD Technologies, Ltd.

NL8060BC31-50F

Note3: Backlight in detail

Backlight

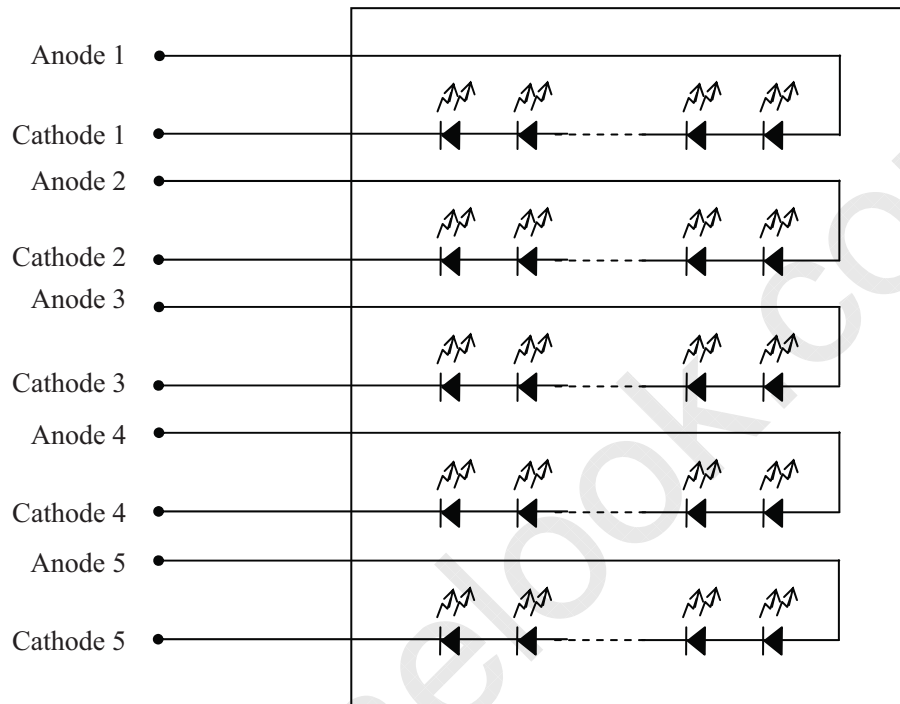

PRELIMINARY

NEC NEC LCD Technologies, Ltd.

NL8060BC31-50F

4. DETAILED SPECIFICATIONS

4.1 MECHANICAL SPECIFICATIONS

Parameter	Specification	Unit
Module size	260.5 ± 0.5 (W) × 203.0 ± 0.5 (H) × 8.7 ± 0.5 (D) Note1	mm
Display area	246.0 (H) × 184.5 (V) Note1	mm
Weight	490 (typ.), 540 (max.)	g

Note1: See "8. OUTLINE DRAWINGS".

4.2 ABSOLUTE MAXIMUM RATINGS

Parameter		Symbol	Rating	Unit	Remarks
Power supply voltage	LCD panel signal processing board	VCC	-0.3 to +6.5	V	Ta = 25°C
Input voltage for signals	Display signals Note1	VD	-0.3 to VCC+0.3	V	
	Function signal Note2	VF			
Backlight	Forward current	IL	TBD	mA	per one circuit
	Forward voltage	VL	50	V	per one circuit
Storage temperature		Tst	-30 to +80	°C	-
Operating temperature	Front surface	TopF	-30 to +80	°C	Note3
	Rear surface	TopR	-30 to +80	°C	Note4
Relative humidity Note5	RH	≤ 95	%	Ta ≤ 40°C	
		≤ 85	%	40°C < Ta ≤ 50°C	
		≤ 55	%	50°C < Ta ≤ 60°C	
		≤ 36	%	60°C < Ta ≤ 70°C	
Absolute humidity Note5		AH	≤ 70 Note6	g/m ³	Ta > 70°C

Note1: CLK, Hsync, Vsync, DE, DATA (R0 to R5, G0 to G5, B0 to B5)

Note2: DPS

Note3: Measured at center of LCD panel surface (including self-heat)

Note4: Measured at center of LCD module's rear shield surface (including self-heat)

Note5: No condensation

Note6: Water amount at Ta= 70°C and RH= 36%

PRELIMINARY

NEC NEC LCD Technologies, Ltd.

NL8060BC31-50F

4.3 ELECTRICAL CHARACTERISTICS

4.3.1 LCD panel signal processing board

(Ta= 25°C)

Parameter	Symbol	min.	typ.	max.	Unit	Remarks
Power supply voltage	VCC	3.0	3.3	3.6	V	at VCC= 3.3V
		4.75	5.0	5.25	V	at VCC= 5.0V
Power supply current	ICC	-	TBD Note1	TBD Note2	mA	at VCC= 3.3V
		-	TBD Note1	TBD Note2	mA	at VCC= 5.0V
Logic input voltage for display signals	High	VDH	0.7VCC	-	VCC	CMOS level
	Low	VDL	0	-	0.3VCC	
Input voltage for DPS signal	High	VFH	0.7VCC	-	VCC	
	Low	VFL	0	-	0.3VCC	

Note1: Checkered flag pattern [by EIAJ ED-2522]

Note2: Pattern for maximum current

PRELIMINARY

NEC NEC LCD Technologies, Ltd.

NL8060BC31-50F

4.3.2 Backlight lamp

(Ta= 25°C, Note1, Note2)

Parameter	Symbol	min.	typ.	max.	Unit	Remarks
Forward current	IL	-	50.0	55.0	mA	-
Forward Voltage	VL	21.2	24.0	27.2	V	Ta= +25°C at IL= 50mA /One circuit
		19.28	-	-		Ta= +80°C at IL= 50mA /One circuit
		-	-	29.84		Ta= -30°C at IL= 50mA /One circuit
		-	-	30.56		Ta= -30°C at IL= 55mA /One circuit

Note1: Please drive with constant current.

Note2: The Luminance uniformity may be changed depending on the current variation between 5 circuits.

It is recommended that the current value difference among the circuits be less than 5%.

4.3.3 Power supply voltage ripple

This product works if the ripple voltage levels are over the permissible values as the following table, but there might be noise on the display image.

Power supply voltage		Ripple voltage (Measure at input terminal of power supply)	Unit
VCC	3.3 V	≤ 100	mVp-p
	5.0 V	≤ 100	mVp-p

Note1: The permissible ripple voltage includes spike noise.

4.3.4 Fuse

Parameter	Fuse		Rating	Fusing current	Remarks
	Type	Supplier			
VCC	TBD	TBD	TBD	TBD	Note1
			TBD		

Note1: The power supply's rated current must be more than the fusing current. If it is less than the fusing current, the fuse may not blow in a short time, and then nasty smell, smoke and so on may occur.

PRELIMINARY

NEC NEC LCD Technologies, Ltd.

NL8060BC31-50F

4.4 POWER SUPPLY VOLTAGE SEQUENCE

4.4.1 LCD panel signal processing board

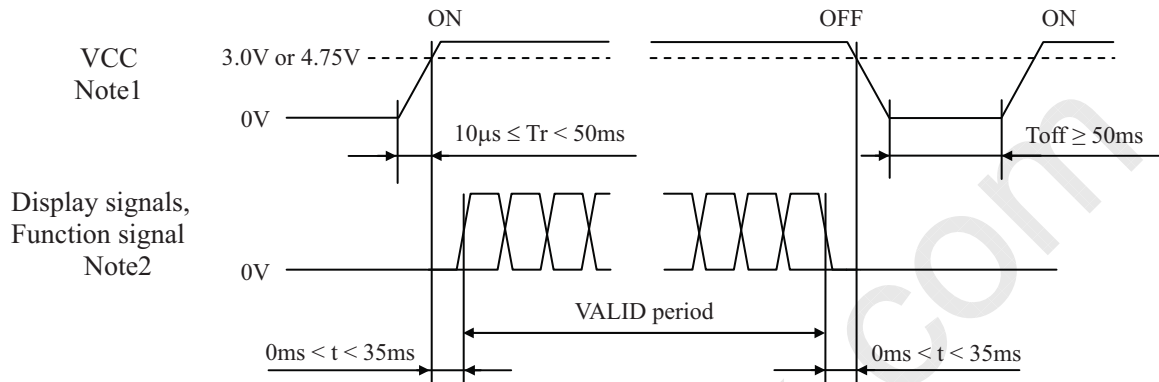

Note1: If there is a voltage variation (voltage drop) at the rising edge of VCC below 3.0V in "VCC = 3.3V" or 4.75V in "VCC = 5.0V", there is a possibility that a product does not work due to a protection circuit.

Note2: Display signals (CLK, Hsync, Vsync, DE, DATA (R0 to R5, G0 to G5, B0 to B5)) and function signal (DPS) must be set to Low or High-impedance, except the VALID period (See above sequence diagram), in order to avoid the circuitry damage.

If some of display and function signals of this product are cut while this product is working, even if the signal input to it once again, it might not work normally. If a customer stops the display and function signals, VCC also must be shut down.

4.4.2 LED Driver board (Option)

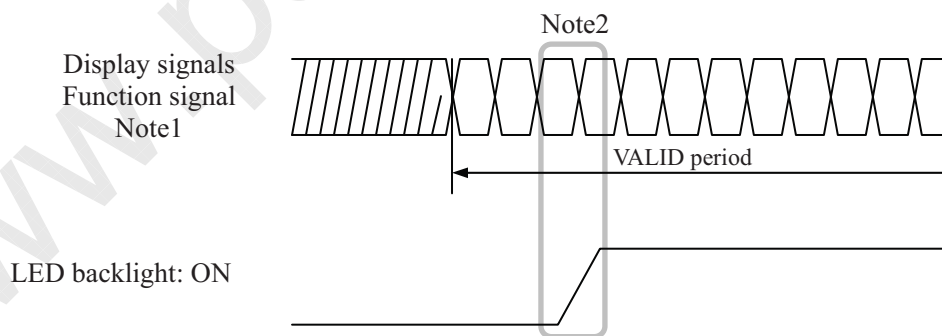

Note1: These are the display and function signals for LCD panel signal processing board.

Note2: The backlight should be turned on within the valid period of display and function signals, in order to avoid unstable data display.

PRELIMINARY

NEC NEC LCD Technologies, Ltd.

NL8060BC31-50F

4.5 CONNECTIONS AND FUNCTIONS FOR INTERFACE PINS

4.5.1 LCD panel signal processing board

CN1 socket (LCD module side): DF9C-41P-1V (2*) (Hirose Electric Co., Ltd. (HRS))

Adaptable plug: DF9-41S-1V (2*), DF9-41S-1V (3*) (Hirose Electric Co., Ltd. (HRS))

Pin No.	Symbol	Signal	Remarks
1	GND	Ground	Note1
2	CLK	Dot clock	-
3	GND	Ground	Note1
4	Hsync	Horizontal synchronous signal	-
5	Vsync	Vertical synchronous signal	-
6	GND	Ground	Note1
7	GND	Ground	
8	GND	Ground	
9	R0	Red data (LSB)	Least significant bit
10	R1	Red data	-
11	R2	Red data	-
12	GND	Ground	Note1
13	R3	Red data	-
14	R4	Red data	-
15	R5	Red data (MSB)	Most significant bit
16	GND	Ground	Note1
17	GND	Ground	
18	GND	Ground	
19	G0	Green data (LSB)	Least significant bit
20	G1	Green data	-
21	G2	Green data	-
22	GND	Ground	Note1
23	G3	Green data	-
24	G4	Green data	-
25	G5	Green data (MSB)	Most significant bit
26	GND	Ground	Note1
27	GND	Ground	
28	GND	Ground	
29	B0	Blue data (LSB)	Least significant bit
30	B1	Blue data	-
31	B2	Blue data	-
32	GND	Ground	Note1
33	B3	Blue data	-
34	B4	Blue data	-
35	B5	Blue data (MSB)	Most significant bit
36	GND	Ground	Note1
37	DE	Selection of DE / Fixed mode	High or Open: Fixed mode Data enable signal: DE mode
38	N. C.	-	Keep this pin Open.
39	VCC	Power supply	Note1
40	VCC	Power supply	
41	DPS	Selection of scan direction	High: Reverse scan Low or Open: Normal scan Note2

Note1: All VCC and GND terminals should be used without any non-connected lines.

Note2: See "4.8 SCANNING DIRECTIONS".

PRELIMINARY

NEC NEC LCD Technologies, Ltd.

NL8060BC31-50F

4.5.2 Backlight lamp

CN2 plug (LCD module side): SM10B-SRSS-TB (J.S.T. Mfg. Co., Ltd.)

Adaptable socket: SHR-10V-S, SHR-10V-S-B (J.S.T. Mfg. Co., Ltd.)

Pin No.	Symbol	Signal	Remarks
1	A1	Anode1	-
2	K1	Cathode1	-
3	A2	Anode2	-
4	K2	Cathode2	-
5	A3	Anode3	-
6	K3	Cathode3	-
7	A4	Anode4	-
8	K4	Cathode4	-
9	A5	Anode5	-
10	K5	Cathode5	-

4.5.3 Positions of plug and socket

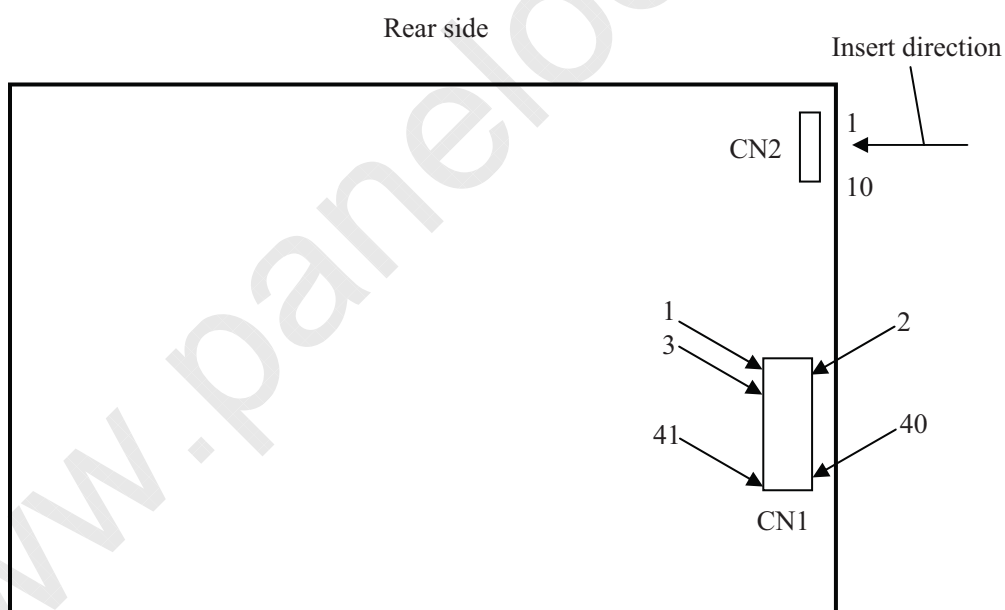

PRELIMINARY

NEC NEC LCD Technologies, Ltd.

NL8060BC31-50F

4.6 DISPLAY COLORS AND INPUT DATA SIGNALS

This product can display 262,144 colors with 64 gray scales. Also the relation between display colors and input data signals is as follows.

Display colors		Data signal (0: Low level, 1: High level)																	
		R5	R4	R3	R2	R1	R0	G5	G4	G3	G2	G1	G0	B5	B4	B3	B2	B1	B0
Basic colors	Black	0	0	0	0	0	0	0	0	0	0	0	0	0	0	0	0	0	0
	Blue	0	0	0	0	0	0	0	0	0	0	0	0	1	1	1	1	1	1
	Red	1	1	1	1	1	1	0	0	0	0	0	0	0	0	0	0	0	0
	Magenta	1	1	1	1	1	1	0	0	0	0	0	0	1	1	1	1	1	1
	Green	0	0	0	0	0	0	1	1	1	1	1	1	0	0	0	0	0	0
	Cyan	0	0	0	0	0	0	1	1	1	1	1	1	1	1	1	1	1	1
	Yellow	1	1	1	1	1	1	1	1	1	1	1	1	0	0	0	0	0	0
	White	1	1	1	1	1	1	1	1	1	1	1	1	1	1	1	1	1	1
Red gray scale	Black	0	0	0	0	0	0	0	0	0	0	0	0	0	0	0	0	0	0
		0	0	0	0	0	1	0	0	0	0	0	0	0	0	0	0	0	0
	dark	0	0	0	0	1	0	0	0	0	0	0	0	0	0	0	0	0	0
	↑				:														
	↓				:														
	bright	1	1	1	1	0	1	0	0	0	0	0	0	0	0	0	0	0	0
Green gray scale	Black	0	0	0	0	0	0	0	0	0	0	0	0	0	0	0	0	0	0
		0	0	0	0	0	0	0	0	0	0	1	0	0	0	0	0	0	0
	dark	0	0	0	0	0	0	0	0	0	0	1	0	0	0	0	0	0	0
	↑				:														
	↓				:														
	bright	0	0	0	0	0	0	1	1	1	1	0	1	0	0	0	0	0	0
Blue gray scale	Black	0	0	0	0	0	0	0	0	0	0	0	0	0	0	0	0	0	0
		0	0	0	0	0	0	0	0	0	0	0	0	0	0	0	0	0	1
	dark	0	0	0	0	0	0	0	0	0	0	0	0	0	0	0	0	1	0
	↑				:														
	↓				:														
	bright	0	0	0	0	0	0	0	0	0	0	0	0	1	1	1	1	0	1
Blue		0	0	0	0	0	0	0	0	0	0	0	1	1	1	1	1	0	0
	Blue	0	0	0	0	0	0	0	0	0	0	0	1	1	1	1	1	1	1

PRELIMINARY

NEC NEC LCD Technologies, Ltd.

NL8060BC31-50F

4.7 DISPLAY POSITIONS

The following table is the coordinates per pixel (See "4.8 SCANNING DIRECTIONS").

C (0, 0)													
<table border="1" style="margin: auto;"> <tr> <td style="padding: 2px;">R</td> <td style="padding: 2px;">G</td> <td style="padding: 2px;">B</td> <td colspan="4"></td> </tr> </table>							R	G	B				
R	G	B											
C(0, 0)	C(1, 0)	...	C(X, 0)	...	C(798, 0)	C(799, 0)							
C(0, 1)	C(1, 1)	...	C(X, 1)	...	C(798, 1)	C(799, 1)							
⋮	⋮	⋮	⋮	⋮	⋮	⋮							
C(0, Y)	C(1, Y)	...	C(X, Y)	...	C(798, Y)	C(799, Y)							
⋮	⋮	⋮	⋮	⋮	⋮	⋮							
C(0, 598)	C(1, 598)	...	C(X, 598)	...	C(798, 598)	C(799, 598)							
C(0, 599)	C(1, 599)	...	C(X, 599)	...	C(798, 599)	C(799, 599)							

4.8 SCANNING DIRECTIONS

The following figures are seen from a front view. Also the arrow shows the direction of scan.

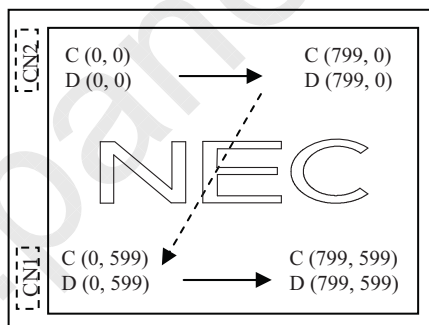

Note1

Figure1. Normal scan (DPS: Low or Open)

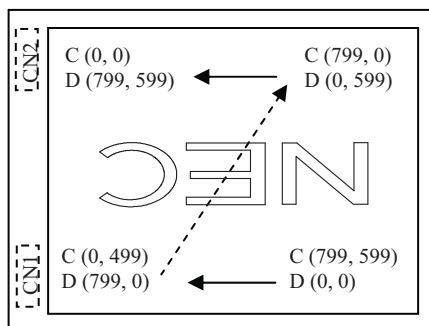

Note1

Figure2. Reverse scan (DPS: High)

Note1: Meaning of C (X, Y) and D (X, Y)

C (X, Y): The coordinates of the display position (See "4.7 DISPLAY POSITIONS").

D (X, Y): The data number of input signal for LCD panel signal processing board

PRELIMINARY

NEC NEC LCD Technologies, Ltd.

NL8060BC31-50F

4.9 INPUT SIGNAL TIMINGS

4.9.1 Outline of input signal timings

• Horizontal signal

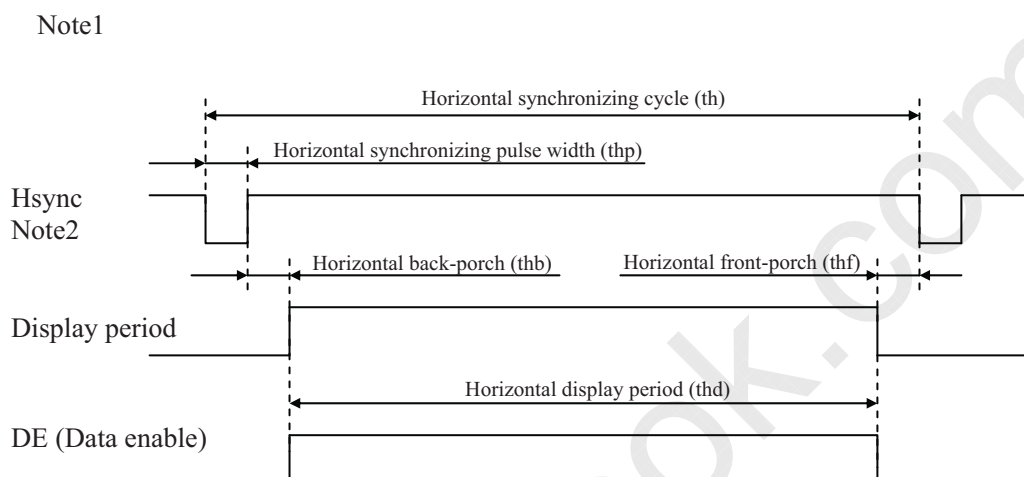

• Vertical signal

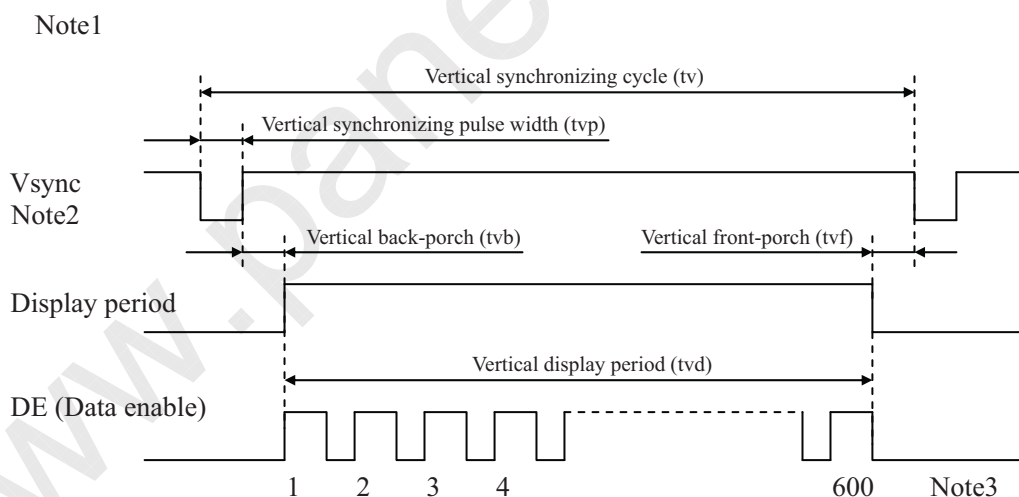

Note1: This diagram indicates virtual signal for set up to timing.

Note2: Fixed mode cannot be used while working of DE mode.

Note3: See "4.9.3 Input signal timing chart" for the pulse number.

PRELIMINARY

NEC NEC LCD Technologies, Ltd.

NL8060BC31-50F

4.9.2 Timing characteristics

(a) Fixed mode

(Note1)

Parameter		Symbol	min.	typ.	max.	Unit	Remarks	
CLK	Frequency	1/tc	34.0	38.362	42.0	MHz	26.067 ns (typ.)	
	Duty	tcd	0.4	0.5	0.6	-		
	Rise time, Fall time	tcrf	-	-	10	ns	-	
DATA (R0-R5) (G0-G5) (B0-B5)	CLK-DATA	Setup time	tds	3	-	-	ns	
		Hold time	tdh	5	-	-	ns	-
	Rise time, Fall time	tdrf	-	-	10	ns		
Hsync	Cycle	th	24.0	26.693	30.1	μs	37.463 kHz (typ.)	
			1,024			CLK		
	Display period	thd	800			CLK		
	Front-porch	thf	24			CLK	-	
	Pulse width	thp	12	72	-	CLK		
	Back-porch	thb	-	128	188	CLK		
	Total of pulse width and back-porch	thp + thb	200			CLK	Note2	
	CLK- Hsync	Setup time	ths	3	-	-	ns	
		Hold time	thh	5	-	-	ns	-
	Rise time, Fall time	thrf	-	-	10	ns		
Vsync	Cycle	tv	16.1	16.683	17.2	ms	59.94 Hz (typ.)	
			625			H		
	Display period	tvd	600			H		
	Front-porch	tvf	1			H	-	
	Pulse width	tvp	1	2	-	H		
	Back-porch	tvb	-	22	23	H		
	Total of pulse width and back-porch	tvp + tvb	24			H	Note2	
	Hsync-Vsync	Setup time	tvhs	3	-	-	ns	
		Hold time	tvhh	5	-	-	ns	-
	Rise time, Fall time	tvrf	-	-	10	ns		

Note1: Definition of parameters is as follows.

tc = 1CLK, tcd = tch/tc, th = 1H

Note2: Keep tvp + tvb and thp + thb within the table. If it is out of specification, display position will be shifted to right/left side or up/down.

PRELIMINARY

NEC NEC LCD Technologies, Ltd.

NL8060BC31-50F

(b) DE mode

(Note1, Note2, Note3)

Parameter		Symbol	min.	typ.	max.	Unit	Remarks	
CLK	Frequency	1/tc	34.0	38.362	42.0	MHz	26.067 ns (typ.)	
	Duty	tcd	0.4	0.5	0.6	-	-	
	Rise time, Fall time	trcf	-	-	10	ns	-	
DATA (R0-R5) (G0-G5) (B0-B5)	CLK-DATA	Setup time	tds	3	-	-	ns	-
		Hold time	tdh	5	-	-	ns	-
	Rise time, Fall time	tdrf	-	-	10	ns	-	
DE	Horizontal	Cycle	th	24.0	26.693	30.1	μs	37.463 kHz (typ.)
				-	1,024	-	CLK	-
	Horizontal	Display period	thd	800			CLK	-
		Vertical (One frame)	Cycle	tv	16.1	16.683	17.2	ms
	-				625	-	H	-
	Vertical (One frame)	Display period	tvd	600			H	-
		CLK-DE	Setup time	tdes	3	-	-	ns
	Hold time		tdeh	5	-	-	ns	-
Rise time, Fall time	tderf	-	-	10	ns	-		

Note1: Definition of parameters is as follows.

$$tc = 1\text{CLK}, tcd = tch/tc, th = 1H$$

Note2: Hsync signal (Pin No.3 of CN1) and Vsync signal (Pin No.4 of CN1) are not used inside the product at DE mode.

Do not keep pin open to avoid noise problem.

Note3: Vertical cycle (tv) should be specified in integral multiple of Horizontal cycle (th).

PRELIMINARY

NEC NEC LCD Technologies, Ltd.

NL8060BC31-50F

4.9.3 Input signal timing chart

(a) Fixed mode

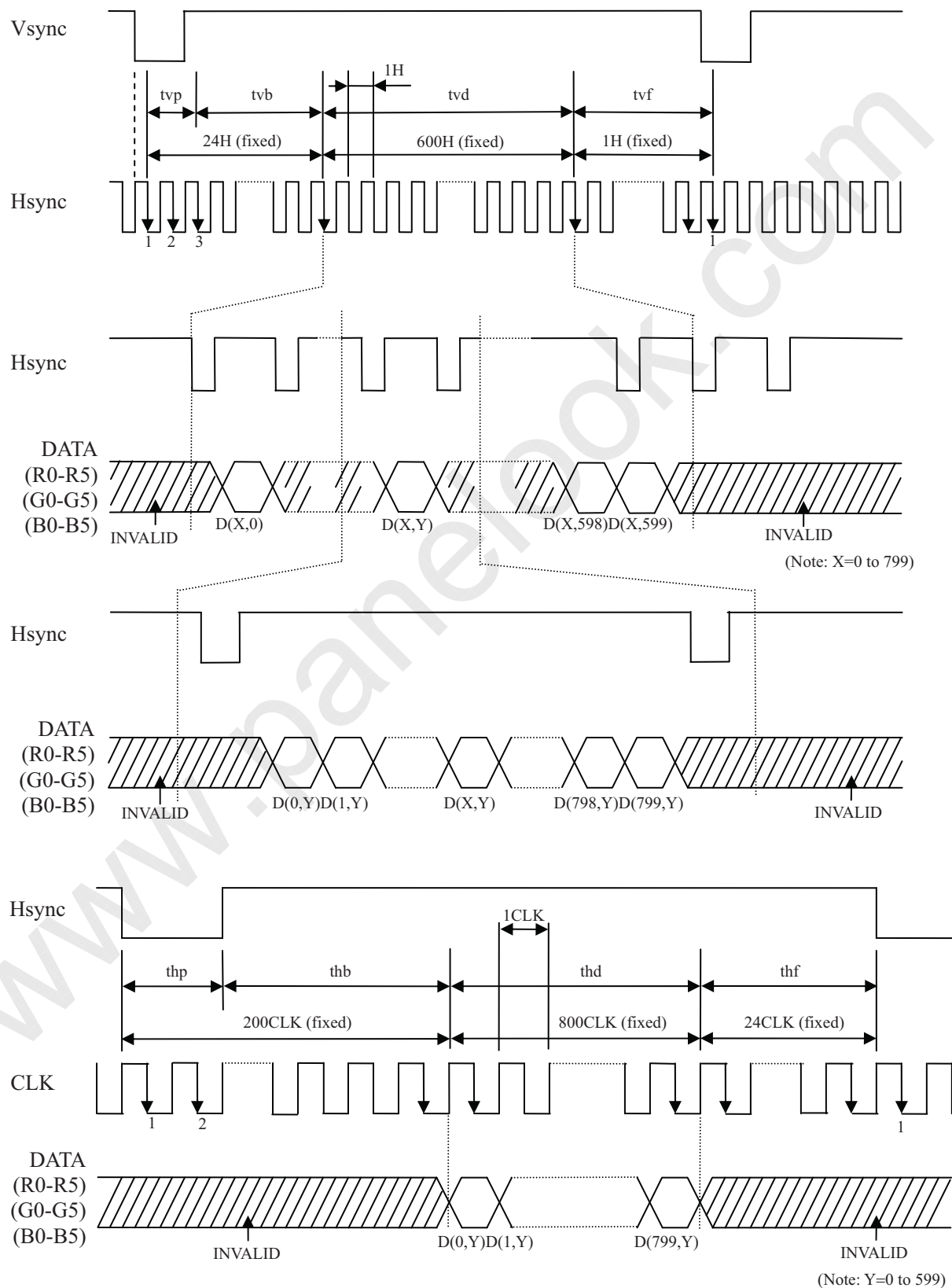

PRELIMINARY

NEC NEC LCD Technologies, Ltd.

NL8060BC31-50F

(b) DE mode

Horizontal timing

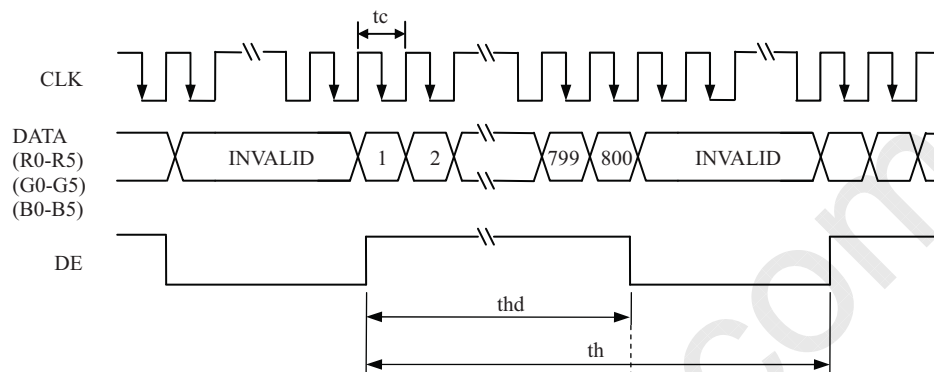

Vertical timing

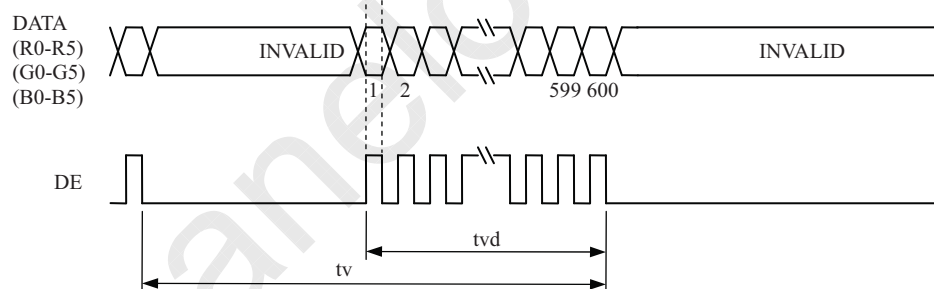

PRELIMINARY

NEC NEC LCD Technologies, Ltd.

NL8060BC31-50F

(c) Common item of Fixed mode and DE mode

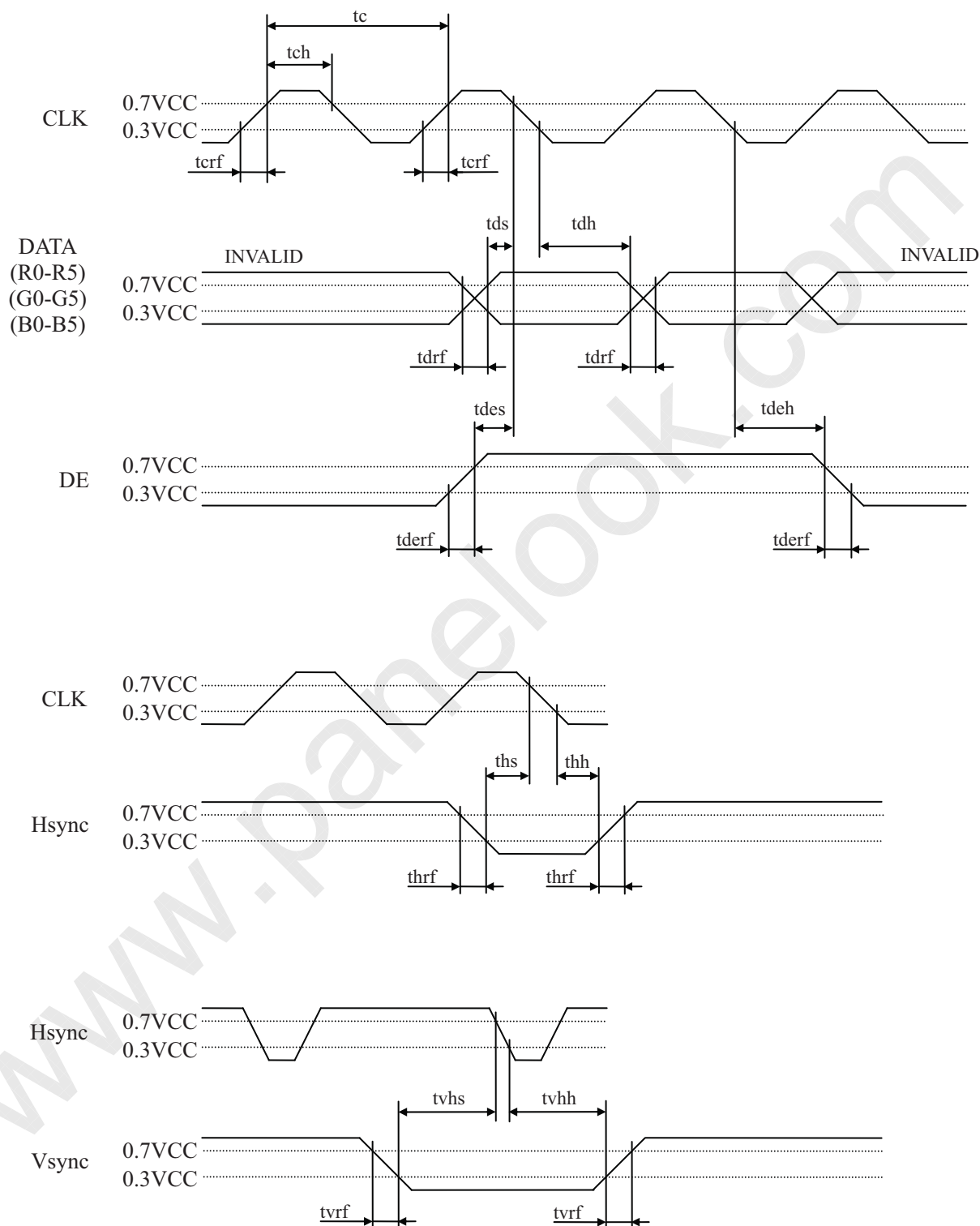

PRELIMINARY

NEC NEC LCD Technologies, Ltd.

NL8060BC31-50F

4.10 OPTICS

4.10.1 Optical characteristics

(Note1, Note2)

Parameter	Condition	Symbol	min.	typ.	max.	Unit	Measuring instrument	Remarks	
Luminance	White at center $\theta R=0^\circ, \theta L=0^\circ, \theta U=0^\circ, \theta D=0^\circ$	L	TBD	800	-	cd/m ²	BM-5A	-	
Contrast ratio	White/Black at center $\theta R=0^\circ, \theta L=0^\circ, \theta U=0^\circ, \theta D=0^\circ$	CR	TBD	800	-	-	BM-5A	Note3	
Luminance uniformity	White $\theta R=0^\circ, \theta L=0^\circ, \theta U=0^\circ, \theta D=0^\circ$	LU	-	1.25	1.4	-	BM-5A	Note4	
Chromaticity	White	x coordinate	W _x	0.283	0.313	0.343	-	SR-3	Note5
		y coordinate	W _y	0.299	0.329	0.359	-		
	Red	x coordinate	R _x	-	TBD	-	-		
		y coordinate	R _y	-	TBD	-	-		
	Green	x coordinate	G _x	-	TBD	-	-		
		y coordinate	G _y	-	TBD	-	-		
Blue	x coordinate	B _x	-	TBD	-	-			
	y coordinate	B _y	-	TBD	-	-			
Color gamut	$\theta R=0^\circ, \theta L=0^\circ, \theta U=0^\circ, \theta D=0^\circ$ at center, against NTSC color space	C	35	40	-	%			
Response time	White to Black	T _{on}	-	TBD	TBD	ms	BM-5A	Note6	
	Black to White	T _{off}	-	TBD	TBD	ms		Note7	
Viewing angle	Right	$\theta U=0^\circ, \theta D=0^\circ, CR \geq 10$	θR	70	80	-	EZ Contrast	Note8	
	Left	$\theta U=0^\circ, \theta D=0^\circ, CR \geq 10$	θL	70	80	-			
	Up	$\theta R=0^\circ, \theta L=0^\circ, CR \geq 10$	θU	70	80	-			
	Down	$\theta R=0^\circ, \theta L=0^\circ, CR \geq 10$	θD	70	80	-			

Note1: These are initial characteristics.

Note2: Measurement conditions are as follows.

T_a= 25°C, VCC= 3.3V, I_L= 50 mA/One circuit, Display mode: SVGA, Horizontal cycle= 1/37.463kHz, Vertical cycle = 1/59.94Hz, DPS= Low or Open: Normal scan

Optical characteristics are measured at luminance saturation 20minutes after the product works in the dark room. Also measurement methods are as follows.

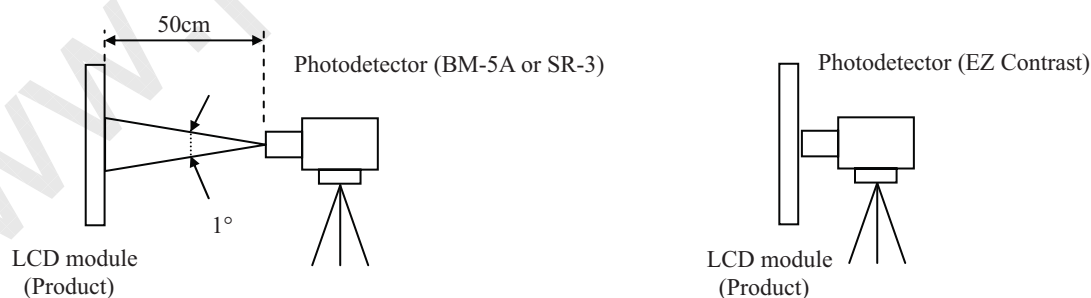

Note3: See "4.10.2 Definition of contrast ratio".

Note4: See "4.10.3 Definition of luminance uniformity".

Note5: These coordinates are found on CIE 1931 chromaticity diagram.

Note6: Product surface temperature: TopF= TBD°C

Note7: See "4.10.4 Definition of response times".

Note8: See "4.10.5 Definition of viewing angles".

PRELIMINARY

NEC LCD Technologies, Ltd.

NL8060BC31-50F

4.10.2 Definition of contrast ratio

The contrast ratio is calculated by using the following formula.

$$\text{Contrast ratio (CR)} = \frac{\text{Luminance of white screen}}{\text{Luminance of black screen}}$$

4.10.3 Definition of luminance uniformity

The luminance uniformity is calculated by using following formula.

$$\text{Luminance uniformity (LU)} = \frac{\text{Maximum luminance from ① to ⑤}}{\text{Minimum luminance from ① to ⑤}}$$

The luminance is measured at near the 5 points shown below.

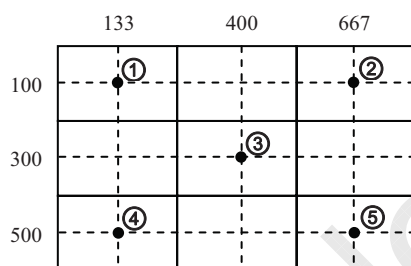

4.10.4 Definition of response times

Response time is measured at the time when the luminance changes from "white" to "black", or "black" to "white" on the same screen point, by photo-detector. Ton is the time when the luminance changes from 90% down to 10%. Also Toff is the time when the luminance changes from 10% up to 90% (See the following diagram.).

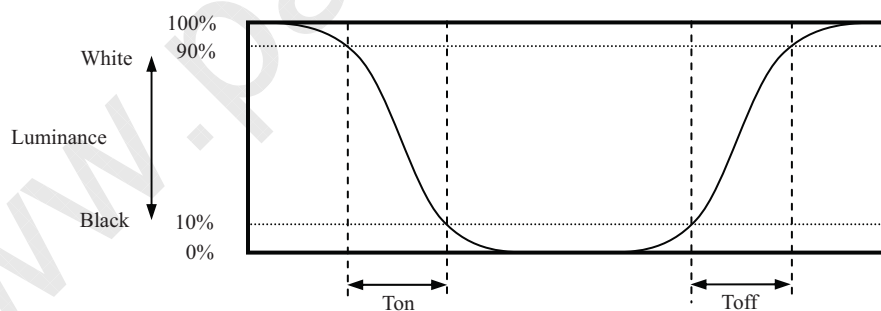

4.10.5 Definition of viewing angles

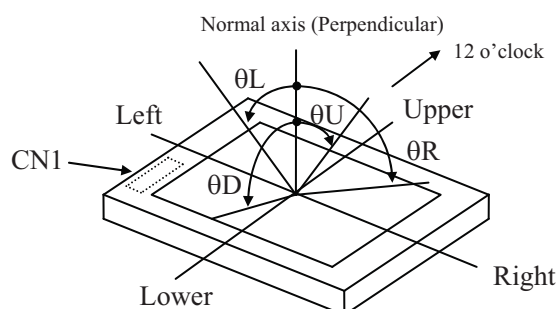

PRELIMINARY

NEC NEC LCD Technologies, Ltd.

NL8060BC31-50F

5. ESTIMATED LUMINANCE LIFETIME

The luminance lifetime is the time from initial luminance to half-luminance.

This lifetime is the estimated value, and is not guarantee value.

Condition		Estimated luminance lifetime (Life time expectancy) Note1, Note2, Note3	Unit
LED elementary substance	25°C (Ambient temperature of the product) Continuous operation, IL= 50mA/One circuit	70,000	h
	80°C (Surface temperature at screen) Continuous operation, IL= 50mA/One circuit	TBD	h

Note1: Life time expectancy is mean time to half-luminance.

Note2: Estimated luminance lifetime is not the value for an LCD module but the value for LED elementary substance.

Note3: By ambient temperature, the lifetime changes particularly. Especially, in case the product works under high temperature environment, the lifetime becomes short.

PRELIMINARY

NEC NEC LCD Technologies, Ltd.

NL8060BC31-50F

6. RELIABILITY TESTS

Test item	Condition	Judgment	Note1
High temperature and humidity (Operation)	① $60 \pm 2^\circ\text{C}$, RH= 90%, 240hours ② Display data is black.	No display malfunctions	
High temperature (Operation)	① $80 \pm 3^\circ\text{C}$, 240hours ② Display data is black.		
Heat cycle (Operation)	① $-30 \pm 3^\circ\text{C} \dots 1\text{hour}$ $80 \pm 3^\circ\text{C} \dots 1\text{hour}$ ② 50cycles, 4 hours/cycle ③ Display data is black.		
Thermal shock (Non operation)	① $-30 \pm 3^\circ\text{C} \dots 30\text{minutes}$ $80 \pm 3^\circ\text{C} \dots 30\text{minutes}$ ② 100cycles, 1hour/cycle ③ Temperature transition time is within 5 minutes.		
ESD (Operation)	① 150pF, 150 Ω , $\pm 10\text{kV}$ ② 9 places on a panel surface Note2 ③ 10 times each places at 1 sec interval		
Dust (Operation)	① Sample dust: No. 15 (by JIS-Z8901) ② 15 seconds stir ③ 8 times repeat at 1 hour interval		
Vibration (Non operation)	① 5 to 100Hz, 19.6m/s ² ② 1 minute/cycle ③ X, Y, Z directions ④ 120 times each directions	No display malfunctions No physical damages	
Mechanical shock (Non operation)	① 539m/s ² , 11ms ② $\pm X$, $\pm Y$, $\pm Z$ directions ③ 5 times each directions		

Note1: Display and appearance are checked under environmental conditions equivalent to the inspection conditions of defect criteria.

Note2: See the following figure for discharge points.

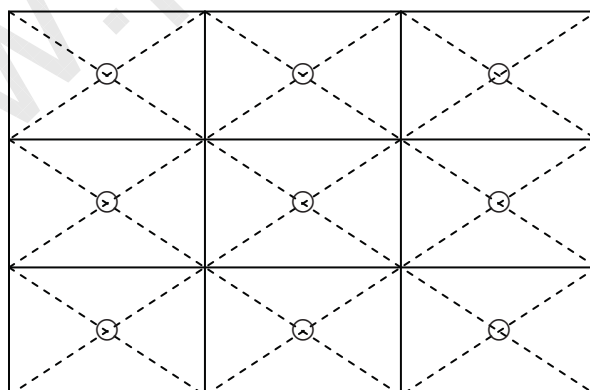

PRELIMINARY

NEC NEC LCD Technologies, Ltd.

NL8060BC31-50F

7. PRECAUTIONS

7.1 MEANING OF CAUTION SIGNS

The following caution signs have very important meaning. **Be sure to read "7.2 CAUTIONS" and "7.3 ATTENTIONS"!**



This sign has the meaning that a customer will be injured or the product will sustain damage if the customer practices wrong operations.



This sign has the meaning that a customer will be injured if the customer practices wrong operations.

7.2 CAUTIONS



*** Do not shock and press the LCD panel and the backlight! There is a danger of breaking, because they are made of glass. (Shock: Equal to or no greater than 539m/s² and equal to or no greater than 11ms, Pressure: Equal to or no greater than 19.6 N (φ16mm jig))**

7.3 ATTENTIONS



7.3.1 Handling of the product

- ① Take hold of both ends without touching the circuit board when the product (LCD module) is picked up from inner packing box to avoid broken down or misadjustment, because of stress to mounting parts on the circuit board.
- ② When the product is put on the table temporarily, display surface must be placed downward.
- ③ When handling the product, take the measures of electrostatic discharge with such as earth band, ionic shower and so on, because the product may be damaged by electrostatic.
- ④ The torque for product mounting screws must never exceed 0.147N·m. Higher torque might result in distortion of the bezel.
- ⑤ The product must be installed using mounting holes without undue stress such as bends or twist (See outline drawings). And do not add undue stress to any portion (such as bezel flat area). Bends or twist described above and undue stress to any portion may cause display mura.
- ⑥ Do not press or rub on the sensitive product surface. When cleaning the product surface, wipe it with a soft dry cloth.
- ⑦ Do not push or pull the interface connectors while the product is working.
- ⑧ When handling the product, use of an original protection sheet on the product surface (polarizer) is recommended for protection of product surface. Adhesive type protection sheet may change color or characteristics of the polarizer.
- ⑨ Usually liquid crystals don't leak through the breakage of glasses because of the surface tension of thin layer and the construction of LCD panel. But, if you contact with liquid crystal by any chance, please wash it away with soap and water.

PRELIMINARY

NEC NEC LCD Technologies, Ltd.

NL8060BC31-50F

7.3.2 Environment

- ① Do not operate or store in high temperature, high humidity, dewdrop atmosphere or corrosive gases. Keep the product in packing box with antistatic pouch in room temperature to avoid dusts and sunlight, when storing the product.
- ② In order to prevent dew condensation occurred by temperature difference, the product packing box must be opened after enough time being left under the environment of an unpacking room. Evaluate the storage time sufficiently because dew condensation is affected by the environmental temperature and humidity. (Recommended leaving time: 6 hours or more with the original packing state after a customer receives the package)
- ③ Do not operate in high magnetic field. If not, circuit boards may be broken.
- ④ This product is not designed as radiation hardened.

7.3.3 Characteristics

The following items are neither defects nor failures.

- ① Characteristics of the LCD (such as response time, luminance, color uniformity and so on) may be changed depending on ambient temperature. If the product is stored under condition of low temperature for a long time, it may cause display mura. In this case, the product should be operated after enough time being left under condition of operating temperature.
- ② Display mura, flickering, vertical streams or tiny spots may be observed depending on display patterns.
- ③ Do not display the fixed pattern for a long time because it may cause image sticking. Use a screen saver, if the fixed pattern is displayed on the screen.
- ④ The display color may be changed depending on viewing angle because of the use of condenser sheet in the backlight.
- ⑤ Optical characteristics may be changed depending on input signal timings.

7.3.4 Other

- ① All GND and VCC terminals should be used without any non-connected lines.
- ② Do not disassemble a product or adjust variable resistors.
- ③ See "REPLACEMENT MANUAL FOR LAMP HOLDER SET", when replacing lamp holder set.
- ④ Pack the product with the original shipping package, in order to avoid any damages during transportation, when returning the product to NEC for repairing and so on.

PRELIMINARY

NEC NEC LCD Technologies, Ltd.

NL8060BC31-50F

8. OUTLINE DRAWINGS

8.1 FRONT VIEW

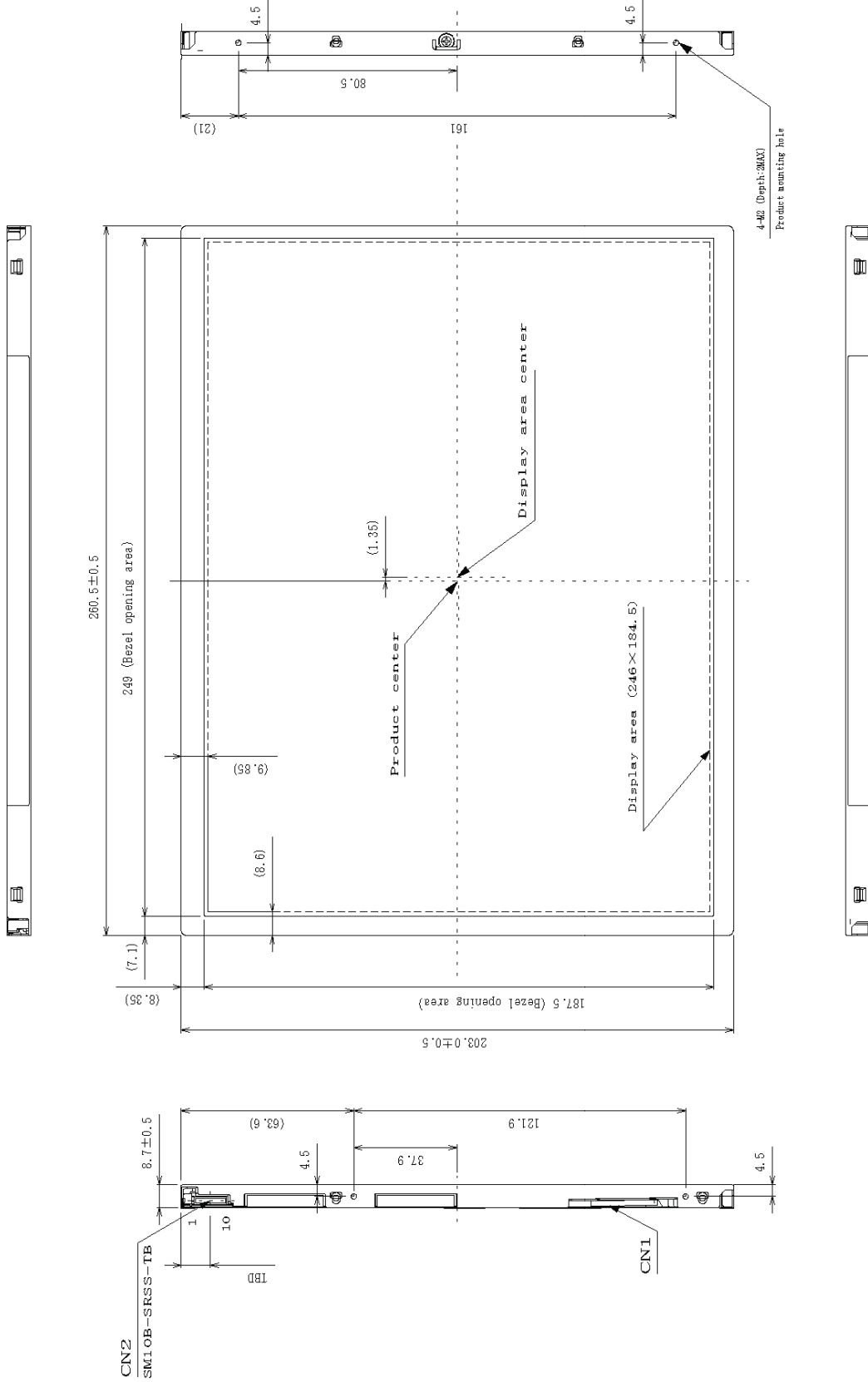

Note1: The values in parentheses are for reference.

Note2: The torque for product mounting screws must never exceed 0.147 N·m.

Note3: Labels stuck on LCD module surface are not included in the module outline.

Unit: mm

PRELIMINARY

NEC NEC LCD Technologies, Ltd.

NL8060BC31-50F

8.2 REAR VIEW

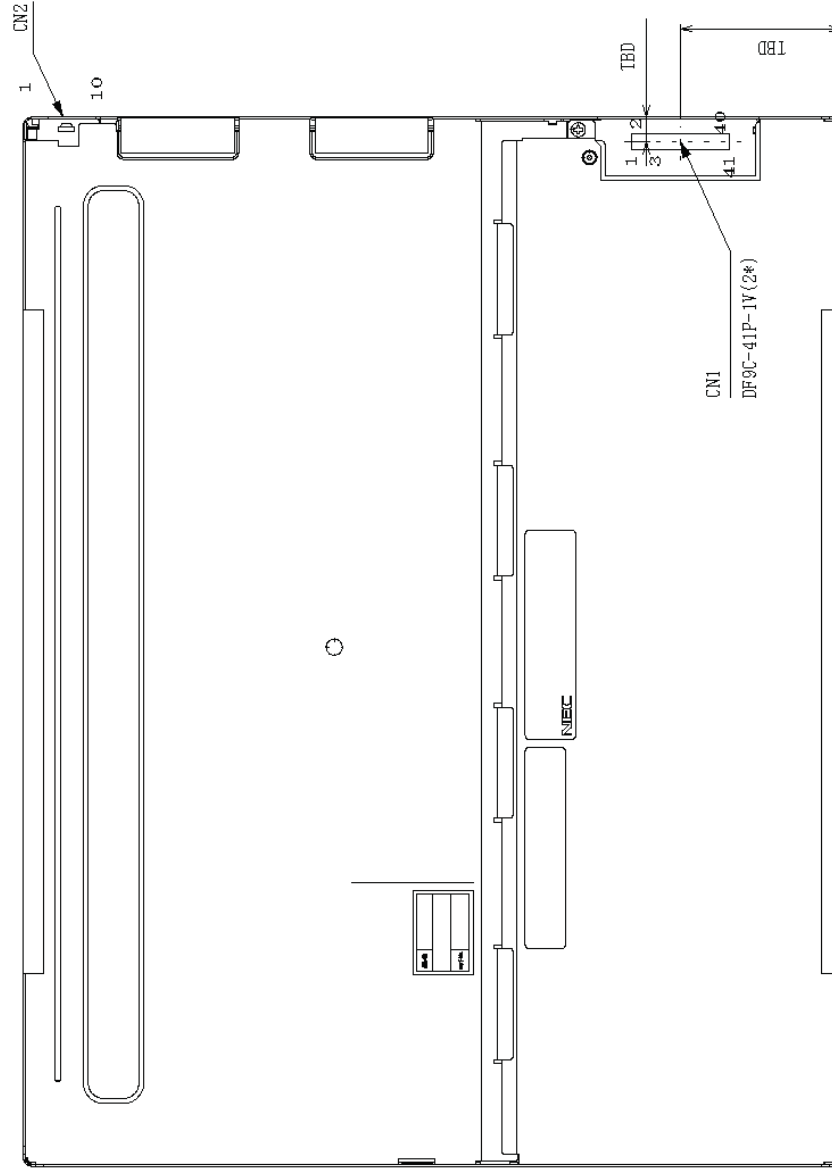

Note1: The values in parentheses are for reference.

Note2: The torque for product mounting screws must never exceed 0.147 N·m.

Note3: Labels stuck on LCD module surface are not included in the module outline.

Unit: mm

PRELIMINARY

NEC NEC LCD Technologies, Ltd.

NL8060BC31-50F

REVISION HISTORY

The inside of latest specifications is revised to the clerical error and the major improvement of previous edition. Only a changed part such as functions, characteristic value and so on that may affect a design of customers, are described especially below.

Edition	Document number	Prepared date	Revision contents and signature
1st edition	DOD-PP-0991	Apr. 23, 2010	<p>Revision contents</p> <p>New issue</p> <p>Signature of writer</p> <p>Approved by <i>T. Ogawa</i> Checked by _____ Prepared by <i>A. Kumano</i></p> <p>_____ _____ _____</p> <p>T. OGAWA _____ A. KUMANO</p>
<p style="text-align: center; opacity: 0.2; font-size: 48px; transform: rotate(-30deg);">www.panelook.com</p>			