

**ARM® Cortex®-M**  
**32-bit Microcontroller**

**NuMicro® Family**  
**NM1200/NM1100 Series**  
**Datasheet**

*The information described in this document is the exclusive intellectual property of Nuvoton Technology Corporation and shall not be reproduced without permission from Nuvoton.*

*Nuvoton is providing this document only for reference purposes of NuMicro microcontroller based system design. Nuvoton assumes no responsibility for errors or omissions.*

*All data and specifications are subject to change without notice.*

For additional information or questions, please contact: Nuvoton Technology Corporation.

[www.nuvoton.com](http://www.nuvoton.com)

*Table of Contents*

- 1 GENERAL DESCRIPTION ..... 7
- 2 FEATURES ..... 8
- 3 ABBREVIATIONS ..... 11
- 4 PARTS INFORMATION LIST AND PIN CONFIGURATION ..... 12
  - 4.1 NuMicro® NM1200/NM1100 Series Naming Rule ..... 12
  - 4.2 NuMicro® NM1200/NM1100 Series Product Selection Guide ..... 13
  - 4.3 PIN CONFIGURATION ..... 14
    - 4.3.1 LQFP 48-pin ..... 14
    - 4.3.2 QFN 33-pin ..... 15
    - 4.3.3 TSSOP 20-pin ..... 16
  - 4.4 Pin Description ..... 17
- 5 BLOCK DIAGRAM ..... 22
  - 5.1 NuMicro® NM1200/NM1100 Block Diagram ..... 22
- 6 Functional Description ..... 23
  - 6.1 ARM® Cortex®-M0 Core ..... 23
    - 6.1.1 Overview ..... 23
    - 6.1.2 Features ..... 23
  - 6.2 System Manager ..... 25
    - 6.2.1 Overview ..... 25
    - 6.2.2 System Reset ..... 25
    - 6.2.3 System Power Architecture ..... 26
    - 6.2.4 System Memory Mapping ..... 28
    - 6.2.5 Memory Organization ..... 28
    - 6.2.6 System Timer (SysTick) ..... 30
    - 6.2.7 Nested Vectored Interrupt Controller (NVIC) ..... 31
  - 6.3 Clock Controller ..... 34
    - 6.3.1 Overview ..... 34
    - 6.3.2 Auto-trim ..... 36
    - 6.3.3 System Clock and SysTick Clock ..... 36
    - 6.3.4 Peripherals Clock Source Selection ..... 37
    - 6.3.5 Power-down Mode Clock ..... 38
    - 6.3.6 Frequency Divider Output ..... 38
  - 6.4 Flash Memory Controller (FMC) ..... 40

- 6.4.1 Overview ..... 40
- 6.4.2 Features ..... 40
- 6.5 General Purpose I/O (GPIO) ..... 41
  - 6.5.1 Overview ..... 41
  - 6.5.2 Features ..... 41
- 6.6 Timer Controller (TMR) ..... 42
  - 6.6.1 Overview ..... 42
  - 6.6.2 Features ..... 42
- 6.7 Enhanced PWM Generator (EPWM) ..... 43
  - 6.7.1 Overview ..... 43
  - 6.7.2 Features ..... 43
- 6.8 Watchdog Timer (WDT) ..... 46
  - 6.8.1 Overview ..... 46
  - 6.8.2 Features ..... 46
- 6.9 UART Controller (UART) ..... 47
  - 6.9.1 Overview ..... 47
  - 6.9.2 Features ..... 47
- 6.10 I<sup>2</sup>C Serial Interface Controller (I<sup>2</sup>C) ..... 48
  - 6.10.1 Overview ..... 48
  - 6.10.2 Features ..... 48
- 6.11 Serial Peripheral Interface (SPI) ..... 49
  - 6.11.1 Overview ..... 49
  - 6.11.2 Features ..... 49
- 6.12 Analog-to-Digital Converter (ADC) ..... 50
  - 6.12.1 Overview ..... 50
  - 6.12.2 Features ..... 50
- 6.13 Analog Comparator (ACMP) ..... 51
  - 6.13.1 Overview ..... 51
  - 6.13.2 Features ..... 51
- 6.14 Hardware Divider (HDIV) ..... 52
  - 6.14.1 Overview ..... 52
  - 6.14.2 Features ..... 52
- 7 APPLICATION CIRCUIT ..... 53
- 8 ELECTRICAL CHARACTERISTICS ..... 54
  - 8.1 Absolute Maximum Ratings ..... 54

- 8.2 DC Electrical Characteristics .....55
- 8.3 AC Electrical Characteristics .....60
  - 8.3.1 External Input Clock ..... 60
  - 8.3.2 External 4~24 MHz High Speed Crystal (HXT) ..... 60
  - 8.3.3 Typical Crystal Application Circuits ..... 60
  - 8.3.4 48 MHz Internal High Speed RC Oscillator (HIRC) ..... 61
  - 8.3.5 10 kHz Internal Low Speed RC Oscillator (LIRC) ..... 61
- 8.4 Analog Characteristics .....62
  - 8.4.1 10-bit SAR ADC ..... 62
  - 8.4.2 LDO & Power Management ..... 63
  - 8.4.3 Brown-out Detector ..... 63
  - 8.4.4 Power-on Reset ..... 64
  - 8.4.5 Comparator ..... 64
- 8.5 Flash DC Electrical Characteristics .....65
- 9 PACKAGE DIMENSIONS ..... 66
  - 9.1 48-pin LQFP .....66
  - 9.2 33-pin QFN (5 mm x 5 mm) .....67
  - 9.3 20-pin TSSOP .....68
- 10 REVISION HISTORY ..... 69

**List of Figures**

Figure 4.1-1 NuMicro® NM1200/NM1100 Series Naming Rule ..... 12

Figure 4.3-1 NuMicro® NM1200/NM1100 Series LQFP 48-pin Diagram..... 14

Figure 4.3-2 NuMicro® NM1200/NM1100 Series QFN 33-pin Diagram..... 15

Figure 4.3-3 NuMicro® NM1100 Series TSSOP 20-pin Diagram..... 16

Figure 5.1-1 NuMicro® NM1200/NM1100 Series Block Diagram ..... 22

Figure 6.1-1 Functional Block Diagram..... 23

Figure 6.2-1 System Rese Resources ..... 26

Figure 6.2-2 NuMicro® NM1200/NM1100 Series Power Architecture Diagram..... 27

Figure 6.3-1 Clock Generator Block Diagram ..... 34

Figure 6.3-2 Clock Generator Global View Diagram..... 35

Figure 6.3-3 System Clock Block Diagram ..... 36

Figure 6.3-4 SysTick Clock Control Block Diagram ..... 37

Figure 6.3-5 Peripherals Bus Clock Source Selection for PCLK ..... 37

Figure 6.3-6 Clock Source of Frequency Divider ..... 39

Figure 6.3-7 Block Diagram of Frequency Divider ..... 39

Figure 6.7-1 Application Circuit Diagram ..... 45

Figure 8-1 NM1200/NM1100 Typical Crystal Application Circuit..... 61

**List of Tables**

Table 3-1 List of Abbreviations..... 11

Table 4.2-1 NuMicro® NM1200/NM1100 Series Product Selection Guide ..... 13

Table 4.4-1 NuMicro® NM1200/NM1100 Series Pin Description ..... 21

Table 6.2-1 Memory Mapping Table ..... 28

Table 6.2-2 Address Space Assignments for On-Chip Modules ..... 29

Table 6.2-3 Exception Model ..... 32

Table 6.2-4 System Interrupt Map Vector Table ..... 33

Table 6.2-5 Vector Table Format ..... 33

Table 6.3-1 Peripheral Clock Source Selection Table ..... 38

## 1 GENERAL DESCRIPTION

The NuMicro® NM1200/NM1100 series 32-bit microcontroller is embedded with ARM® Cortex®-M0 core for industrial control and applications which require high performance, high integration, and low cost. The Cortex®-M0 is the newest ARM® embedded processor with 32-bit performance at a cost equivalent to the traditional 8-bit microcontroller.

The NM1200/NM1100 series can run up to 48 MHz and operate at 2.1V ~ 5.5V, -40°C ~ 105°C, and thus can afford to support a variety of industrial control and applications which need high CPU performance. The NM1200/NM1100 series offers 17.5K-bytes embedded program flash, size configurable Data Flash (shared with program flash), 2K-byte flash for the ISP, and 2K-byte SRAM.

Many system level peripheral functions, such as I/O Port, Timer, UART, SPI, I<sup>2</sup>C, PWM, ADC, Watchdog Timer, Analog Comparator and Brown-out Detector, have been incorporated into the NM1200/NM1100 series in order to reduce component count, board space and system cost. These useful functions make the NM1200/NM1100 series powerful for a wide range of applications.

Additionally, the NM1200/NM1100 series is equipped with ISP (In-System Programming) and ICP (In-Circuit Programming) functions, which allow the user to update the program memory without removing the chip from the actual end product. The NM1200/NM1100 series also supports In-Application-Programming (IAP) function, user switches the code executing without the chip reset after the embedded flash updated.

## 2 FEATURES

- Core
  - ARM® Cortex®-M0 core running up to 48 MHz
  - One 24-bit system timer
  - Supports low power Idle mode
  - A single-cycle 32-bit hardware multiplier
  - NVIC for the 32 interrupt inputs, each with 4-level of priority
  - Supports Serial Wire Debug (SWD) interface and two watchpoints/four breakpoints
- Built-in LDO for wide operating voltage: 2.1V to 5.5V
- Memory
  - 17.5 KB Flash memory for program memory (APROM)
  - Configurable Flash memory for data memory (Data Flash)
  - 2 KB Flash for loader (LDROM)
  - 2 KB SRAM for internal scratch-pad RAM (SRAM)
- Clock Control
  - Programmable system clock source
    - ◆ Switch clock sources on-the-fly
  - Support 4 ~ 24 MHz external high speed crystal oscillator (HXT) for precise timing operation
  - Support 32.768 kHz external low speed crystal oscillator (LXT) for idle wake-up and system operation clock
  - Built-in 48 MHz internal high speed RC oscillator (HIRC) for system operation (1% accuracy at 25°C, 5V)
    - ◆ Dynamically calibrating the HIRC OSC to 48 MHz  $\pm 2\%$  from -40°C to 105°C by external 32.768K crystal oscillator (LXT)
  - Built-in 10 kHz internal low speed RC oscillator (LIRC) for Watchdog Timer and wake-up operation
- I/O Port
  - Up to 33 general-purpose I/O (GPIO) pins for LQFP-48 package
  - Four I/O modes:
    - ◆ Quasi-bidirectional input/output
    - ◆ Push-Pull output
    - ◆ Open-Drain output
    - ◆ Input only with high impedance
  - Optional Schmitt trigger input
- Timer
  - Provides two channel 32-bit Timers; one 8-bit pre-scaler counter with 24-bit up-timer for each timer
    - ◆ Supports Event Counter mode



- ◆ Supports Toggle Output mode
- ◆ Supports external trigger in Pulse Width Measurement mode
- ◆ Supports external trigger in Pulse Width Capture mode
- ◆ Support advanced capture function can continuous capture 4 edge on one signal
- WDT (Watchdog Timer)
  - Programmable clock source and time-out period
  - Supports wake-up function in Power-down mode and Idle mode
  - Interrupt or reset selectable on watchdog time-out
- PWM
  - Up to three built-in 16-bit PWM generators, providing six PWM outputs or three complementary paired PWM outputs
  - Individual clock source, clock divider, 8-bit pre-scalar and dead-time generator for each PWM generator
  - PWM interrupt synchronized to PWM period
  - Supports edge-alignment or center-alignment
  - Supports fault detection
- UART (Universal Asynchronous Receiver/Transmitters)
  - Two UART devices
  - Buffered receiver and transmitter, 16-byte FIFO for first UART (UART0), and 4-byte FIFO for second UART (UART1)
  - Optional flow control function (CTS<sub>n</sub> and RTS<sub>n</sub>) in first UART 0 only
  - Supports IrDA (SIR) function
  - Programmable baud-rate generator up to 1/16 system clock
  - Supports RS-485 function
- SPI (Serial Peripheral Interface)
  - One SPI device
  - Master up to 25 MHz, and Slave up to 10 MHz
  - Supports Master/Slave mode
  - Full-duplex synchronous serial data transfer
  - Variable length of transfer data from 8 to 32 bits
  - MSB or LSB first data transfer
  - RX latching data can be either at rising edge or at falling edge of serial clock
  - TX sending data can be either at rising edge or at falling edge of serial clock
  - Supports Byte Suspend mode in 32-bit transmission
- I<sup>2</sup>C
  - Supports Master/Slave mode
  - Bidirectional data transfer between masters and slaves
  - Multi-master bus (no central master)

- Arbitration between simultaneously transmitting masters without corruption of serial data on the bus
- Serial clock synchronization allowing devices with different bit rates to communicate via one serial bus
- Serial clock synchronization can be used as a handshake mechanism to suspend and resume serial transfer
- Programmable clocks allow for versatile rate control
- Supports multiple address recognition (four slave addresses with mask option)
- ADC (Analog-to-Digital Converter)
  - 10-bit SAR ADC with 500 kSPS
  - Up to 12-ch single-end input and one internal input from band-gap
  - Conversion started either by software trigger or external pin trigger
- Analog Comparator
  - Two analog comparators with programmable 16-level internal voltage reference
  - Built-in CRV (comparator reference voltage)
- Hardware Divider
  - Signed (two's complement) integer calculation
  - 32-bit dividend with 16-bit divisor calculation capacity
  - 32-bit quotient and 32-bit remainder outputs (16-bit remainder with sign extends to 32-bit)
  - Divided by zero warning flag
  - 6 HCLK clocks taken for one cycle calculation
  - Waiting for calculation ready automatically when reading quotient and remainder
- ISP (In-System Programming), ICP (In-Circuit Programming), and IAP (In-Application-Programming) update
- BOD (Brown-out Detector)
  - With 8 programmable threshold levels:  
4.4V/3.7V/3.0V/2.7V/2.4V/2.2V/2.0V/1.7V
  - Supports Brown-out interrupt and reset option
- 96-bit unique ID
- LVR (Low Voltage Reset)
  - Threshold voltage level: 2.0V
- Operating Temperature: -40°C~105°C
- Reliability: EFT > ± 3KV, ESD HBM pass 6KV
- Packages:
  - 48-pin LQFP (7x7), 33-pin QFN (5x5), 20-pin TSSOP
  - Package is Halogen-free, RoHS-compliant and TSCA-compliant.

### 3 ABBREVIATIONS

Acronym	Description
ACMP	Analog Comparator Controller
ADC	Analog-to-Digital Converter
AHB	Advanced High-Performance Bus
APB	Advanced Peripheral Bus
BOD	Brown-out Detection
DAP	Debug Access Port
FIFO	First In, First Out
FMC	Flash Memory Controller
GPIO	General-Purpose Input/Output
HCLK	The Clock of Advanced High-Performance Bus
HIRC	48 MHz Internal High Speed RC Oscillator
HXT	4~24 MHz External High Speed Crystal Oscillator
ICP	In Circuit Programming
ISP	In System Programming
ISR	Interrupt Service Routine
LDO	Low Dropout Regulator
LIRC	10 kHz internal low speed RC oscillator (LIRC)
LXT	32.768 kHz External Low Speed Crystal Oscillator
NVIC	Nested Vectored Interrupt Controller
PCLK	The Clock of Advanced Peripheral Bus
PLL	Phase-Locked Loop
PWM	Pulse Width Modulation
SPI	Serial Peripheral Interface
SPS	Samples per Second
TMR	Timer Controller
UART	Universal Asynchronous Receiver/Transmitter
UCID	Unique Customer ID
WDT	Watchdog Timer

Table 3-1 List of Abbreviations

4 PARTS INFORMATION LIST AND PIN CONFIGURATION

4.1 NuMicro® NM1200/NM1100 Series Naming Rule

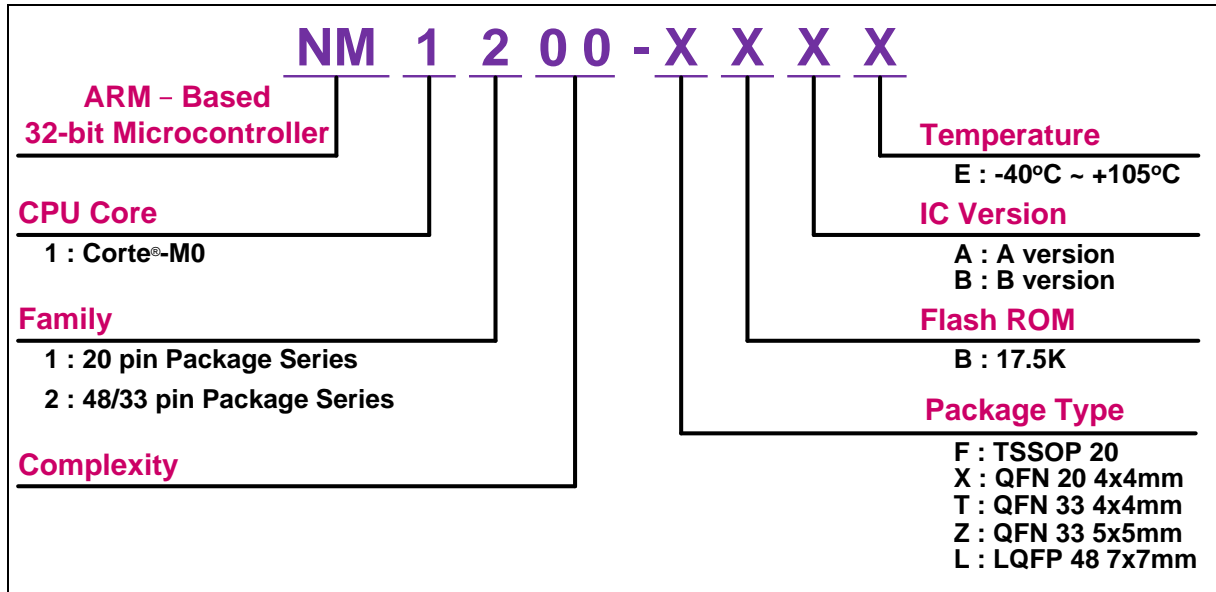

Figure 4.1-1 NuMicro® NM1200/NM1100 Series Naming Rule

4.2 NuMicro® NM1200/NM1100 Series Product Selection Guide

Part Number (Order Number)	APROM	RAM	Data Flash	ISP Loader ROM	I/O	Timer	Connectivity			Comp.	PWM	ADC	ISP ICP IAP	HIRC 48MHz	Package
							UART	SPI	I <sup>2</sup> C						
NM1100FBAE	17.5 KB	2 KB	Configurable	2 KB	up to 17	2x32-bit	1	0	0	2	6	8x10-bit	v	v	TSSOP20
NM1200ZBAE	17.5 KB	2 KB	Configurable	2 KB	up to 29	2x32-bit	2	1	1	2	6	12x10-bit	v	v	QFN33(5x5)
NM1200LBAE	17.5 KB	2 KB	Configurable	2 KB	up to 33	2x32-bit	2	1	1	2	6	12x10-bit	v	v	LQFP48

Table 4.2-1 NuMicro® NM1200/NM1100 Series Product Selection Guide

### 4.3 PIN CONFIGURATION

#### 4.3.1 LQFP 48-pin

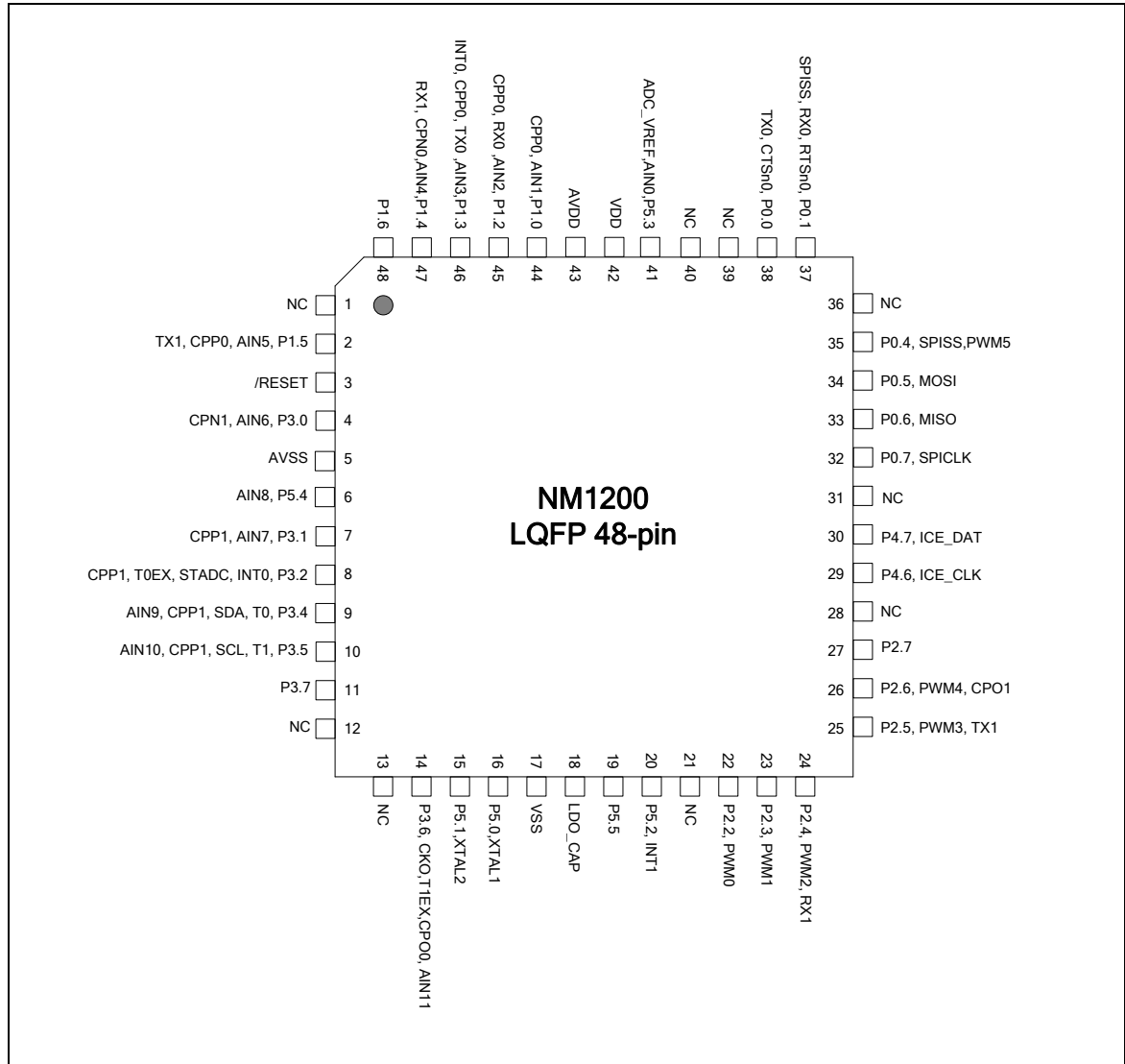

Figure 4.3-1 NuMicro® NM1200/NM1100 Series LQFP 48-pin Diagram

4.3.2 QFN 33-pin

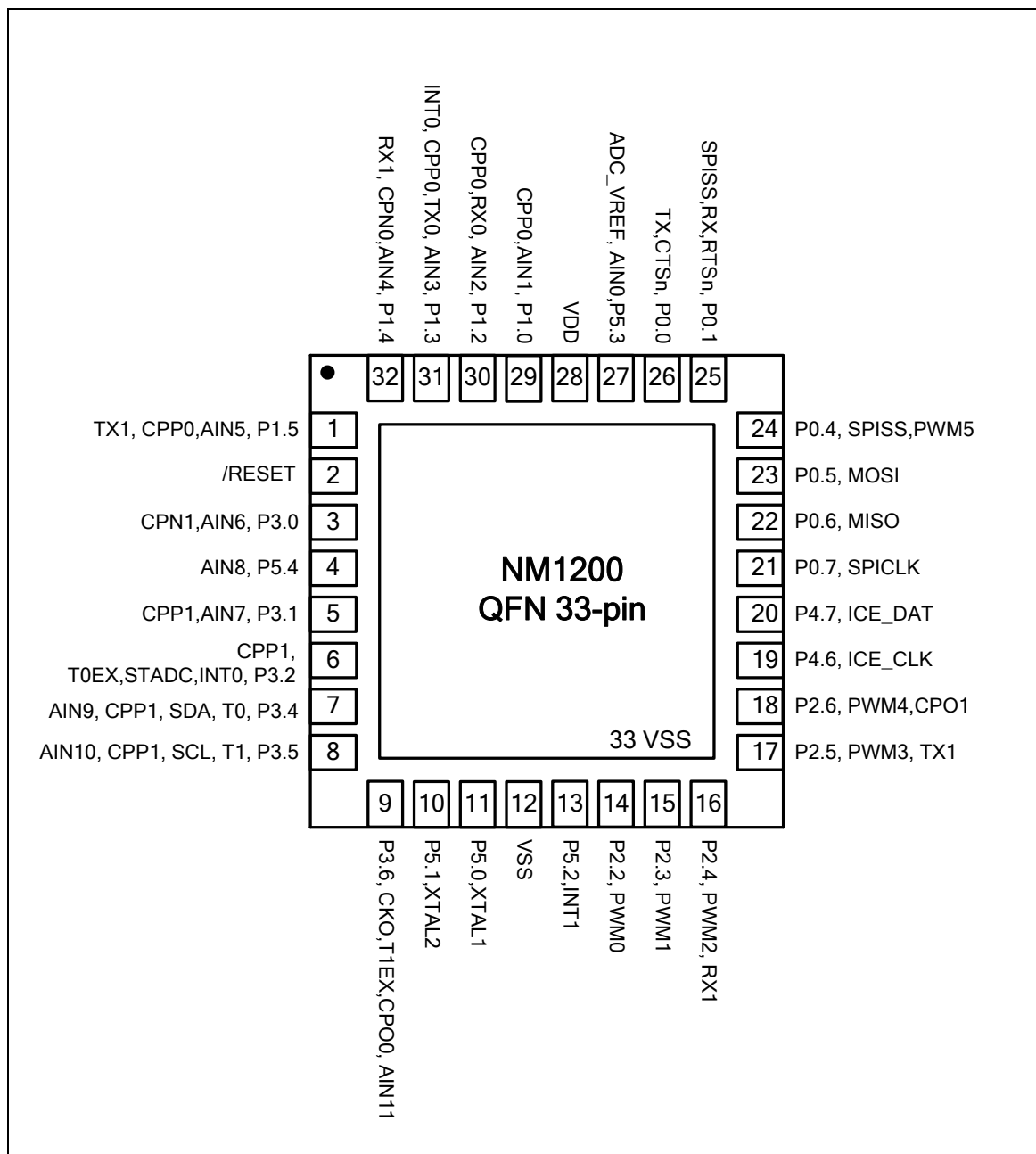

Figure 4.3-2 NuMicro® NM1200/NM1100 Series QFN 33-pin Diagram

4.3.3 TSSOP 20-pin

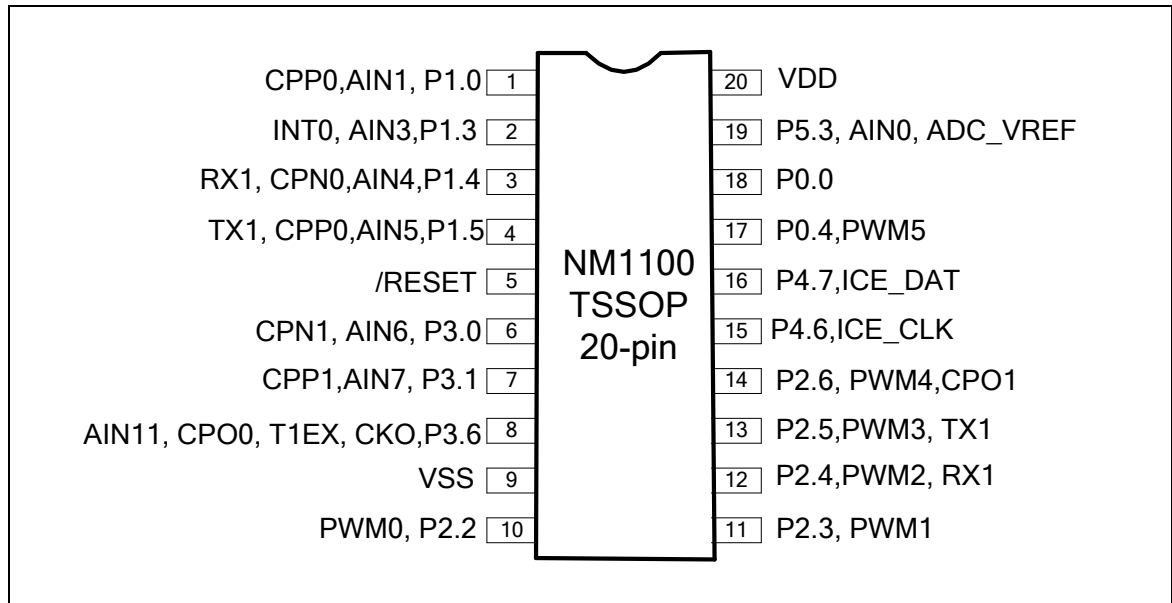

Figure 4.3-3 NuMicro® NM1100 Series TSSOP 20-pin Diagram



4.4 Pin Description

Pin Number			Pin Name	Pin Type	Description
LQFP 48-pin	QFN 33-pin	TSSOP 20-pin			
1			NC		Not connected
2	1	4	P1.5	I/O	General purpose digital I/O pin
			ADC_CH5	AI	ADC analog input pin
			ACMP0_P0	AI	Analog comparator positive input pin
			UART1_TX0	O	UART1 transmitter output pin
3	2	5	/RESET	I(ST)	The Schmitt trigger input pin for hardware device reset. A “Low” on this pin for 768 clock counter of Internal HIRC while the system clock is running will reset the device. /RESET pin has an internal pull-up resistor allowing power-on reset by simply connecting an external capacitor to GND.
4	3	6	P3.0	I/O	General purpose digital I/O pin
			ADC_CH6	AI	ADC analog input pin
			ACMP1_N	AI	Analog comparator negative input pin
			CCAP	I	Continuous Capture input pin
5			AVSS	AP	Ground pin for analog circuit
6	4		P5.4	I/O	General purpose digital I/O pin
			ADC_CH8	AI	ADC analog input pin
7	5	7	P3.1	I/O	General purpose digital I/O pin
			ADC_CH7	AI	ADC analog input pin
			ACMP1_P0	AI	Analog comparator positive input pin
			CCAP	I	Continuous Capture input pin
8	6		P3.2	I/O	General purpose digital I/O pin
			INT0	I	External interrupt 0 input pin
			STADC	I	ADC external trigger input pin
			TM0_EXT	I	Timer 0 external capture/reset trigger input pin
			ACMP1_P1	AI	Analog comparator positive input pin
9	7		P3.4	I/O	General purpose digital I/O pin

			TM0	I/O	Timer 0 external event counter input pin
			I2C_SDA	I/O	I2C data I/O pin
			ACMP1_P2	AI	Analog comparator positive input pin
			ADC_CH9	AI	ADC analog input pin
10	8		P3.5	I/O	General purpose digital I/O pin
			TM1	I/O	Timer 1 external event counter input pin
			I2C_SCL	I/O	I2C clock I/O pin
			ACMP1_P3	AI	Analog comparator positive input pin
			ADC_CH10	AI	ADC analog input pin
11			P3.7	I/O	General purpose digital I/O pin
12			NC		Not connected
13			NC		Not connected
14	9	8	P3.6	I/O	General purpose digital I/O pin
			ACMP0_O	O	Analog comparator output pin
			CKO	O	Frequency divider output pin
			TM1_EXT	I	Timer 1 external capture/reset trigger input pin
			ADC_CH11	AI	ADC analog input pin
15	10		P5.1	I/O	General purpose digital I/O pin
			XTAL2	O	The output pin from the internal inverting amplifier. It emits the inverted signal of XTAL1.
16	11		P5.0	I/O	General purpose digital I/O pin
			XTAL1	I	The input pin to the internal inverting amplifier. The system clock could be from external crystal or resonator.
17	12 33	9	VSS	P	Ground pin for digital circuit
18			LDO_CAP	P	LDO output pin
19			P5.5	I/O	General purpose digital I/O pin User program must enable pull-up resistor in the QFN-33 package.
20	13		P5.2	I/O	General purpose digital I/O pin
			INT1	I	External interrupt 1 input pin

			CCAP	I	Continuous Capture input pin
21			NC		Not connected
22	14	10	P2.2	I/O	General purpose digital I/O pin
			PWM0	O	PWM_CH0 output of PWM unit
23	15	11	P2.3	I/O	General purpose digital I/O pin
			PWM1	O	PWM_CH1 output of PWM unit
24	16	12	P2.4	I/O	General purpose input/output digital pin
			PWM2	O	PWM_CH2 output of PWM unit
			UART1_RX1	I	UART1 data receiver input pin
25	17	13	P2.5	I/O	General purpose digital I/O pin
			PWM3	O	PWM_CH3 output of PWM unit
			UART1_TX1	O	UART1 transmitter output pin
26	18	14	P2.6	I/O	General purpose digital I/O pin
			PWM4	O	PWM_CH4 output of PWM unit
			ACMP1_O	O	Analog comparator output pin
27			P2.7	I/O	General purpose digital I/O pin
28			NC		Not connected
29	19	15	P4.6	I/O	General purpose digital I/O pin
			ICE_CLK	I	Serial wired debugger clock pin
30	20	16	P4.7	I/O	General purpose digital I/O pin
			ICE_DAT	I/O	Serial wired debugger data pin
31			NC		Not connected
32	21		P0.7	I/O	General purpose digital I/O pin
			SPI_CLK	I/O	SPI serial clock pin
			CCAP	I	Continuous Capture input pin
33	22		P0.6	I/O	General purpose digital I/O pin
			SPI_MISO	I/O	SPI MISO (master in/slave out) pin
			CCAP	I	Continuous Capture input pin
34	23		P0.5	I/O	General purpose digital I/O pin
			SPI_MOSI	O	SPI MOSI (master out/slave in) pin
			CCAP	I	Continuous Capture input pin

35	24	17	P0.4	I/O	General purpose digital I/O pin
			SPI_SS	I/O	SPI slave select pin
			PWM5	O	PWM5 output of PWM unit
			CCAP	I	Continuous Capture input pin
36			NC		Not connected
37	25		P0.1	I/O	General purpose digital I/O pin
			nRTS	O	UART0 RTS pin
			UART0_RX0	I	UART0 data receiver input pin
			SPI_SS	I/O	SPI slave select pin
38	26	18	P0.0	I/O	General purpose digital I/O pin
			nCTS	I	UART0 CTS pin
			UART0_TX0	O	UART0 transmitter output pin
39			NC		Not connected
40			NC		Not connected
41	27	19	P5.3	I/O	General purpose digital I/O pin
			ADC_CH0	AI	ADC analog input pin
			ADC VREF	AI	External voltage reference of ADC
42	28	20	VDD	P	Power supply for digital circuit
43			AVDD	P	Power supply for analog circuit
44	29	1	P1.0	I/O	General purpose digital I/O pin
			ADC_CH1	AI	ADC analog input pin
			ACMP0_P1	AI	Analog comparator positive input pin
45	30		P1.2	I/O	General purpose digital I/O pin
			ADC_CH2	AI	ADC analog input pin
			UART0_RX1	I	UART0 data receiver input pin
			ACMP0_P2	AI	Analog comparator positive input pin
46	31	2	P1.3	I/O	General purpose digital I/O pin
			ADC_CH3	AI	ADC analog input pin
			UART0_TX1	O	UART0 transmitter output pin
			ACMP0_P3	AI	Analog comparator positive input pin
			INT0	I	External interrupt 0 input pin

47	32	3	P1.4	I/O	General purpose digital I/O pin
			ADC_CH4	I/O	ADC analog input pin
			ACMP0_N	AI	Analog comparator negative input pin
			UART1_RX0	I	UART1 data receiver input pin
48			P1.6	I/O	General purpose digital I/O pin

Table 4.4-1 NuMicro® NM1200/NM1100 Series Pin Description

[1] I/O type description. I: input, O: output, I/O: quasi bi-direction, D: open-drain, P: power pin, ST: Schmitt trigger, A: Analog input.

[2] Do not leave the pins ICE\_CLK and ICE\_DAT in floating when MCU is in operatoin. User may refer to one of the following methods

- a. Add external pull-up or pull-low resistors at pins.
- b. Set the 2 pins in Quasi-mode and output high to be equivelant to internal pull high.
- c. Be wired to other deivce without floating.

5 BLOCK DIAGRAM

5.1 NuMicro® NM1200/NM1100 Block Diagram

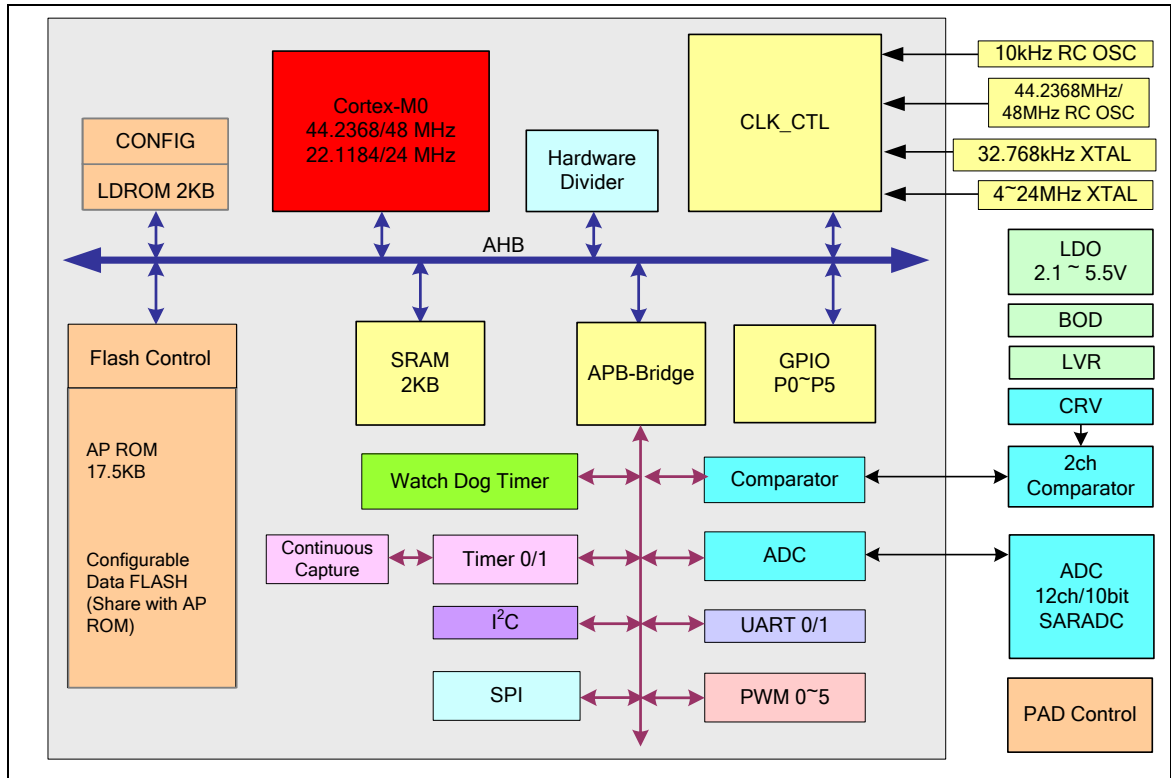

Figure 5.1-1 NuMicro® NM1200/NM1100 Series Block Diagram

## 6 FUNCTIONAL DESCRIPTION

### 6.1 ARM® Cortex®-M0 Core

#### 6.1.1 Overview

The Cortex®-M0 processor, a configurable, multistage, 32-bit RISC processor, has an AMBA AHB-Lite interface and includes an NVIC component. It also has optional hardware debug functionality. The processor can execute Thumb code and is compatible with other Cortex®-M profile processors. The profile supports two modes – Thread mode and Handler mode. Handler mode is entered as a result of an exception. An exception return can only be issued in Handler mode. Thread mode is entered on Reset and can be entered as a result of an exception return. Figure 6.1-1 shows the functional controller of the processor.

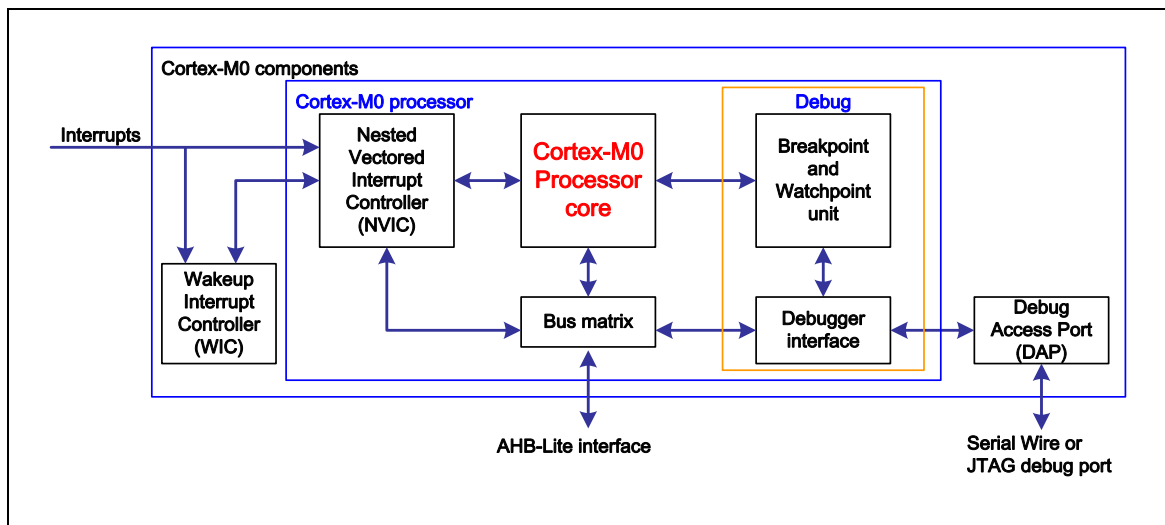

Figure 6.1-1 Functional Block Diagram

#### 6.1.2 Features

- A low gate count processor
  - ARMv6-M Thumb® instruction set
  - Thumb-2 technology
  - ARMv6-M compliant 24-bit SysTick timer
  - A 32-bit hardware multiplier
  - System interface supported with little-endian data accesses
  - Ability to have deterministic, fixed-latency, interrupt handling
  - Load/store-multiples and multicycle-multiplies that can be abandoned and restarted to facilitate rapid interrupt handling
  - C Application Binary Interface compliant exception model:
    - This is the ARMv6-M, C Application Binary Interface (C-ABI) compliant exception model that enables the use of pure C functions as interrupt handlers
  - Low power Idle mode entry using the Wait For Interrupt (WFI), Wait For Event (WFE) instructions, or return from interrupt sleep-on-exit feature

- NVIC
  - 32 external interrupt inputs, each with four levels of priority
  - Dedicated Non-maskable Interrupt (NMI) input
  - Supports for both level-sensitive and pulse-sensitive interrupt lines
  - Supports Wake-up Interrupt Controller (WIC) and, providing Ultra-low Power Idle mode
- Debug support
  - Four hardware breakpoints
  - Two watch points
  - Program Counter Sampling Register (PCSR) for non-intrusive code profiling
  - Single step and vector catch capabilities
- Bus interfaces
  - Single 32-bit AMBA-3 AHB-Lite system interface that provides simple integration to all system peripherals and memory
  - Single 32-bit slave port that supports the DAP (Debug Access Port)



## 6.2 System Manager

### 6.2.1 Overview

System management includes the following sections:

- System Reset
- System Power Architecture
- System Memory Map
- System management registers for Part Number ID, chip reset and on-chip controllers reset, and multi-functional pin control
- System Timer (SysTick)
- Nested Vectored Interrupt Controller (NVIC)
- System Control registers

### 6.2.2 System Reset

The system reset can be issued by one of the following listed events. For these reset events flags can be read by SYS\_RSTSTS register.

- Hardware Reset
  - ◆ Power-on Reset (POR)
  - ◆ Low level on the nRESET pin
  - ◆ Watchdog Time-out Reset (WDT)
  - ◆ Low Voltage Reset (LVR)
  - ◆ Brown-out Detector Reset (BOD)
- Software Reset
  - CPU Reset
    - Write 1 to CPURST (SYS\_IPRST0[1])
  - Whole Chip Reset
    - Write 1 to SYSRESETREQ (SYS\_AIRCR[2])
    - Write 1 to CHIPRST (SYS\_IPRST0[0])

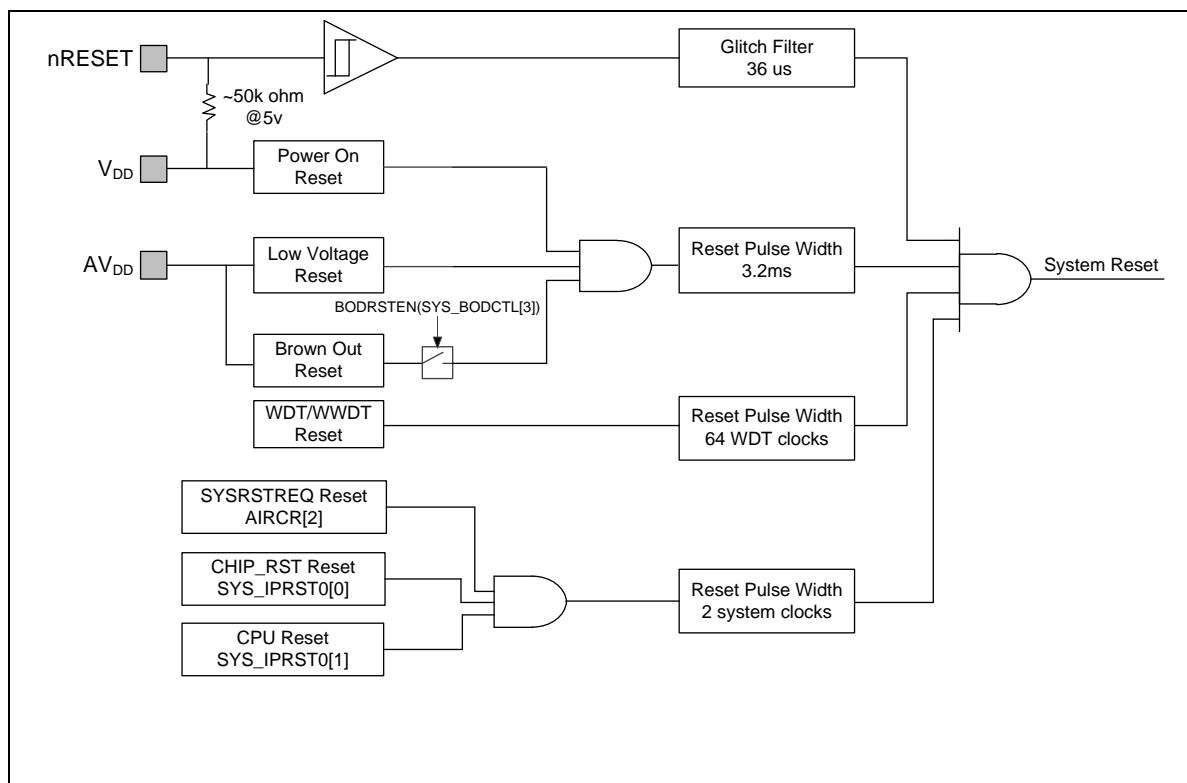

Figure 6.2-1 System Rese Resources

### 6.2.3 System Power Architecture

In this chip, the power distribution is divided into three segments.

- Analog power from AV<sub>DD</sub> and AV<sub>SS</sub> provides the power for analog components operation. AV<sub>DD</sub> must be equal to V<sub>DD</sub> to avoid leakage current.
- Digital power from V<sub>DD</sub> and V<sub>SS</sub> supplies power to the I/O pins and internal regulator which provides a fixed 1.8V power for digital operation.
- Built-in a capacitor for internal voltage regulator

The output of internal voltage regulator, LDO\_CAP, requires an external capacitor which should be located close to the corresponding pin. Analog power (AV<sub>DD</sub>) should be the same voltage level as the digital power (V<sub>DD</sub>). Figure 6.2-2 shows the power distribution of the NM1200/NM1100 series.

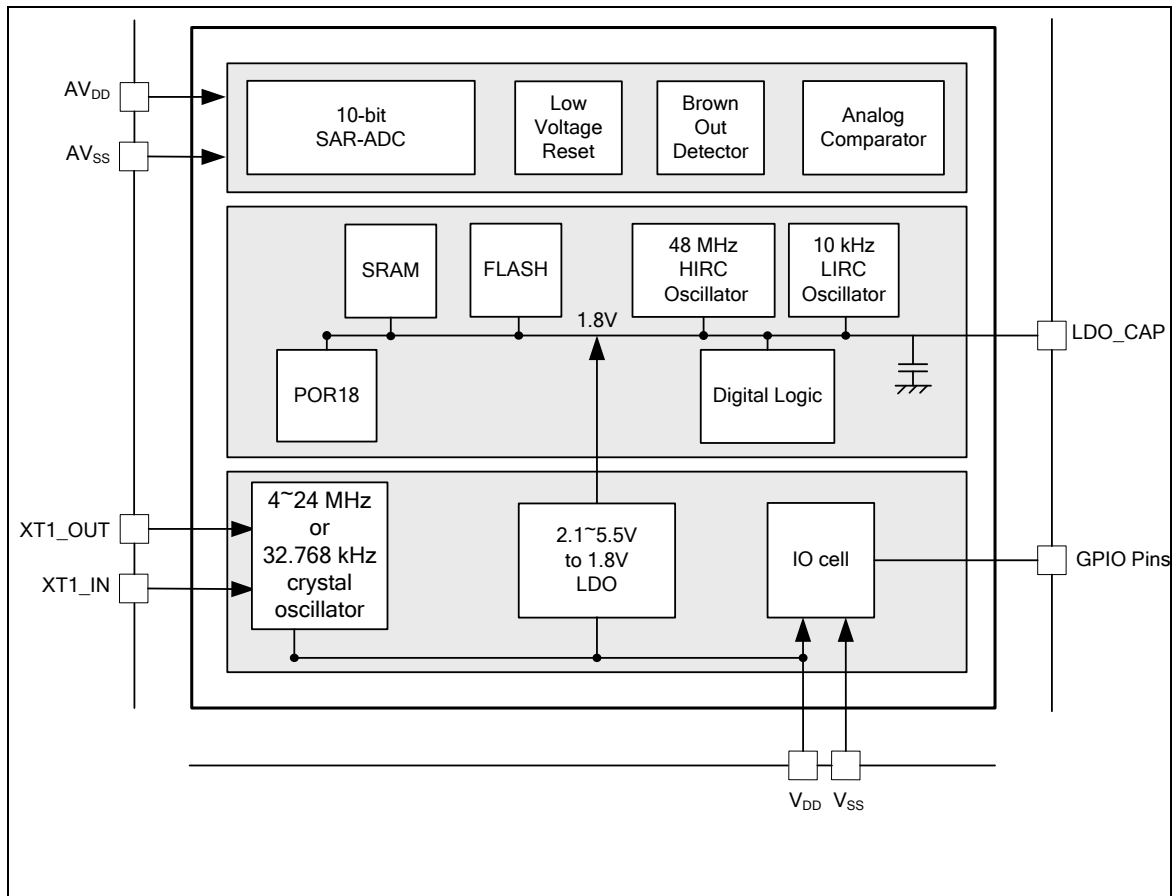

Figure 6.2-2 NuMicro® NM1200/NM1100 Series Power Architecture Diagram

### 6.2.4 System Memory Mapping

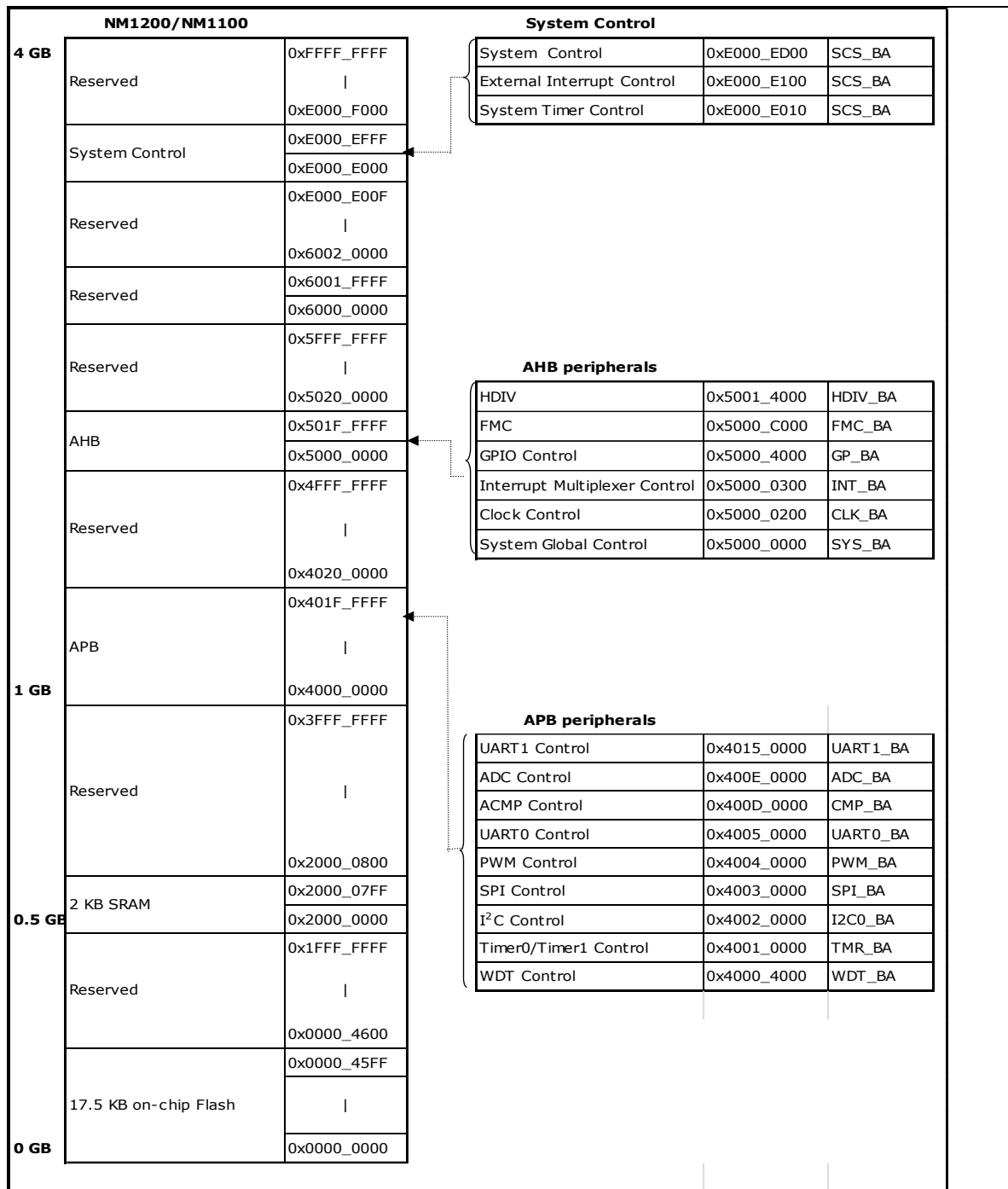

Table 6.2-1 Memory Mapping Table

### 6.2.5 Memory Organization

#### 6.2.5.1 Overview

The NuMicro<sup>®</sup> NM1200/NM1100 series provides 4G-byte addressing space. The addressing

space assigned to each on-chip controllers is shown the following table. The detailed register definition, addressing space, and programming details will be described in the following sections for each on-chip peripheral. The NM1200/NM1100 series only supports little-endian data format.

6.2.5.2 System Memory Map

The memory locations assigned to each on-chip controllers are shown in the following table.

Addressing Space	Token	Modules
<b>Flash and SRAM Memory Space</b>		
0x0000_0000 – 0x0000_45FF	FLASH_BA	Flash Memory Space (17.5 KB)
0x2000_0000 – 0x2000_07FF	SRAM_BA	SRAM Memory Space (2 KB)
<b>AHB Modules Space (0x5000_0000 – 0x501F_FFFF)</b>		
0x5000_0000 – 0x5000_01FF	SYS_BA	System Global Control Registers
0x5000_0200 – 0x5000_02FF	CLK_BA	Clock Control Registers
0x5000_0300 – 0x5000_03FF	INT_BA	Interrupt Multiplexer Control Registers
0x5000_4000 – 0x5000_7FFF	GP_BA	GPIO (P0~P5) Control Registers
0x5000_C000 – 0x5000_FFFF	FMC_BA	Flash Memory Control Registers
0x5001_4000 – 0x5001_7FFF	HDIV_BA	Hardware Divider Control Register
<b>APB Modules Space (0x4000_0000 – 0x401F_FFFF)</b>		
0x4000_4000 – 0x4000_00FF	WDT_BA	Watchdog Timer Control Registers
0x4001_0000 – 0x4001_3FFF	TMR_BA	Timer0/Timer1 Control Registers
0x4002_0000 – 0x4002_3FFF	I2C_BA	I <sup>2</sup> C Interface Control Registers
0x4003_0000 – 0x4003_3FFF	SPI_BA	SPI with Master/slave Function Control Registers
0x4004_0000 – 0x4004_3FFF	PWM_BA	PWM Control Registers
0x4005_0000 – 0x4005_3FFF	UART0_BA	UART0 Control Registers
0x400D_0000 – 0x400D_3FFF	ACMP_BA	Analog Comparator Control Registers
0x400E_0000 – 0x400E_3FFF	ADC_BA	Analog-Digital-Converter (ADC) Control Registers
0x4015_0000 – 0x4015_3FFF	UART1_BA	UART1 Control Registers
<b>System Control Space (0xE000_E000 – 0xE000_EFFF)</b>		
0xE000_E010 – 0xE000_E0FF	SCS_BA	System Timer Control Registers
0xE000_E100 – 0xE000_ECFF	SCS_BA	Nested Vectored Interrupt Control Registers
0xE000_ED00 – 0xE000_ED8F	SCS_BA	System Control Block Registers

Table 6.2-2 Address Space Assignments for On-Chip Modules

### 6.2.6 System Timer (SysTick)

The Cortex®-M0 includes an integrated system timer, SysTick, which provides a simple, 24-bit clear-on-write, decrementing, wrap-on-zero counter with a flexible control mechanism. The counter can be used as a Real Time Operating System (RTOS) tick timer or as a simple counter.

When system timer is enabled, it will count down from the value in the SysTick Current Value Register (SYST\_CVR) to zero, and reload (wrap) to the value in the SysTick Reload Value Register (SYST\_RVR) on the next clock edge, and then decrement on subsequent clocks. When the counter transitions to zero, the COUNTFLAG status bit is set. The COUNTFLAG bit clears on reads.

The SYST\_CVR value is UNKNOWN on reset. Software should write to the register to clear it to zero before enabling the feature. This ensures the timer to count from the SYST\_RVR value rather than an arbitrary value when it is enabled.

If the SYST\_RVR is zero, the timer will be maintained with a current value of zero after it is reloaded with this value. This mechanism can be used to disable the feature independently from the timer enable bit.

For more detailed information, please refer to the “ARM® Cortex®-M0 Technical Reference Manual” and “ARM® v6-M Architecture Reference Manual”.

## 6.2.7 Nested Vectored Interrupt Controller (NVIC)

### 6.2.7.1 Overview

The Cortex®-M0 CPU provides an interrupt controller as an integral part of the exception mode, named as “Nested Vectored Interrupt Controller (NVIC)”, which is closely coupled to the processor core and provides following features.

### 6.2.7.2 Features

- Nested and Vectored interrupt support
- Automatic processor state saving and restoration
- Dynamic priority change
- Reduced and deterministic interrupt latency

The NVIC prioritizes and handles all supported exceptions. All exceptions are handled in “Handler Mode”. This NVIC architecture supports 32 (IRQ[31:0]) discrete interrupts with 4 levels of priority. All of the interrupts and most of the system exceptions can be configured to different priority levels. When an interrupt occurs, the NVIC will compare the priority of the new interrupt to the current running one’s priority. If the priority of the new interrupt is higher than the current one, the new interrupt handler will override the current handler.

When an interrupt is accepted, the starting address of the Interrupt Service Routine (ISR) is fetched from a vector table in memory. There is no need to determine which interrupt is accepted and branch to the starting address of the correlated ISR by software. While the starting address is fetched, NVIC will also automatically save processor state including the registers “PC, PSR, LR, R0~R3, R12” to the stack. At the end of the ISR, the NVIC will restore the mentioned registers from stack and resume the normal execution. Thus it will take less and deterministic time to process the interrupt request.

The NVIC supports “Tail Chaining” which handles back-to-back interrupts efficiently without the overhead of states saving and restoration and therefore reduces delay time in switching to pending ISR at the end of current ISR. The NVIC also supports “Late Arrival” which improves the efficiency of concurrent ISRs. When a higher priority interrupt request occurs before the current ISR starts to execute (at the stage of state saving and starting address fetching), the NVIC will give priority to the higher one without delay penalty. Thus it advances the real-time capability.

For more detailed information, please refer to the “ARM® Cortex®-M0 Technical Reference Manual” and “ARM® v6-M Architecture Reference Manual”.

### 6.2.7.3 Exception Model and System Interrupt Map

The following table lists the exception model supported by NuMicro® NM1200/NM1100 series. Software can set four levels of priority on some of these exceptions as well as on all interrupts. The highest user-configurable priority is denoted as 0 and the lowest priority is denoted as 3. The default priority of all the user-configurable interrupts is 0. Note that the priority 0 is treated as the fourth priority on the system, after three system exceptions “Reset”, “NMI” and “Hard Fault”.

Exception Name	Vector Number	Priority
Reset	1	-3
NMI	2	-2
Hard Fault	3	-1
Reserved	4 ~ 10	Reserved
SVCALL	11	Configurable
Reserved	12 ~ 13	Reserved
PendSV	14	Configurable
SysTick	15	Configurable
Interrupt (IRQ0 ~ IRQ31)	16 ~ 47	Configurable

Table 6.2-3 Exception Model

Exception Number	Interrupt Number (Bit In Interrupt Registers)	Interrupt Name	Source Module	Interrupt Description	Power-down Wake-up
1 ~ 15	-	-	-	System exceptions	-
16	0	<b>BODOUT</b>	Brown-out	Brown-out low voltage detected interrupt	Yes
17	1	<b>WDT_INT</b>	WDT	Watchdog Timer interrupt	Yes
18	2	<b>EINT0</b>	GPIO	External signal interrupt from P3.2 pin	Yes
19	3	<b>EINT1</b>	GPIO	External signal interrupt from P5.2 pin	Yes
20	4	<b>GP0/1_INT</b>	GPIO	External signal interrupt from GPIO group P0~P1	Yes
21	5	<b>GP2/3/4_INT</b>	GPIO	External signal interrupt from GPIO group P2~P4 except P3.2	Yes
22	6	<b>PWM_INT</b>	PWM	PWM interrupt	No
23	7	<b>BRAKE_INT</b>	PWM	PWM Brake interrupt	No
24	8	<b>TMR0_INT</b>	TMR0	Timer 0 interrupt	Yes
25	9	<b>TMR1_INT</b>	TMR1	Timer 1 interrupt	Yes
26 ~ 27	10 ~ 11	-	-	-	-
28	12	<b>UART0_INT</b>	UART0	UART0 interrupt	Yes
29	13	<b>UART1_INT</b>	UART1	UART1 interrupt	Yes
30	14	<b>SPI_INT</b>	SPI	SPI interrupt	No
31	15	-	-	-	-
32	16	<b>GP5_INT</b>	GPIO	External signal interrupt from GPIO group P5 except P5.2	Yes
33	17	<b>HIRC_TRIM_INT</b>	HIRC	HIRC trim interrupt	No
34	18	<b>I2C_INT</b>	I <sup>2</sup> C	I <sup>2</sup> C interrupt	Yes



Exception Number	Interrupt Number (Bit In Interrupt Registers)	Interrupt Name	Source Module	Interrupt Description	Power-down Wake-up
35 ~ 40	19 ~ 24	-	-	-	
41	25	ACMP_INT	ACMP	Analog Comparator 0 or Comparator 1 interrupt	Yes
42 ~ 43	26 ~ 27	-	-	-	
44	28	PWRWU_INT	CLKC	Clock controller interrupt for chip wake-up from Power-down state	Yes
45	29	ADC_INT	ADC	ADC interrupt	No
46 ~ 47	30 ~ 31	-	-	-	

Table 6.2-4 System Interrupt Map Vector Table

6.2.7.4 Vector Table

When an interrupt is accepted, the processor will automatically fetch the starting address of the interrupt service routine (ISR) from a vector table in memory. For ARMv6-M, the vector table based address is fixed at 0x00000000. The vector table contains the initialization value for the stack pointer on reset, and the entry point addresses for all exception handlers. The vector number on previous page defines the order of entries in the vector table associated with the exception handler entry as illustrated in previous section.

Vector Table Word Offset (Bytes)	Description
0x00	Initial Stack Pointer Value
Exception Number * 0x04	Exception Entry Pointer using that Exception Number

Table 6.2-5 Vector Table Format

6.2.7.5 Operation Description

NVIC interrupts can be enabled and disabled by writing to their corresponding Interrupt Set-Enable or Interrupt Clear-Enable register bit-field. The registers use a write-1-to-enable and write-1-to-clear policy, both registers reading back the current enabled state of the corresponding interrupts. When an interrupt is disabled, interrupt assertion will cause the interrupt to become Pending; however, the interrupt will not be activated. If an interrupt is Active when it is disabled, it remains in its Active state until cleared by reset or an exception return. Clearing the enable bit prevents new activations of the associated interrupt.

NVIC interrupts can be pended/un-pended using a complementary pair of registers to those used to enable/disable the interrupts, named the Set-Pending Register and Clear-Pending Register respectively. The registers use a write-1-to-enable and write-1-to-clear policy, both registers reading back the current pended state of the corresponding interrupts. The Clear-Pending Register has no effect on the execution status of an Active interrupt.

NVIC interrupts are prioritized by updating an 8-bit field within a 32-bit register (each register supporting four interrupts).

The general registers associated with the NVIC are all accessible from a block of memory in the System Control Space and will be described in next section.

### 6.3 Clock Controller

#### 6.3.1 Overview

The clock controller generates clocks for the whole chip, including system clocks and all peripheral clocks. The clock controller also implements the power control function with the individually clock ON/OFF control, clock source selection and clock divider. The chip enters Power-down mode when Cortex<sup>®</sup>-M0 core executes the WFI instruction only if the PDEN (CLK\_PWRCTL[7]) bit is set to 1. After that, chip enters Power-down mode and waits for wake-up interrupt source triggered to exit Power-down mode. In Power-down mode, the clock controller turns off the 4~24 MHz external high speed crystal (HXT) and 48 MHz internal high speed RC oscillator (HIRC) to reduce the overall system power consumption. The following figures show the clock generator and the overview of the clock source control.

The clock generator consists of 3 sources as listed below:

- 4~24 MHz external high speed crystal oscillator (HXT) or 32.768 kHz (LXT) external low speed crystal oscillator
- 48 MHz internal high speed RC oscillator (HIRC)
- 10 kHz internal low speed RC oscillator (LIRC)

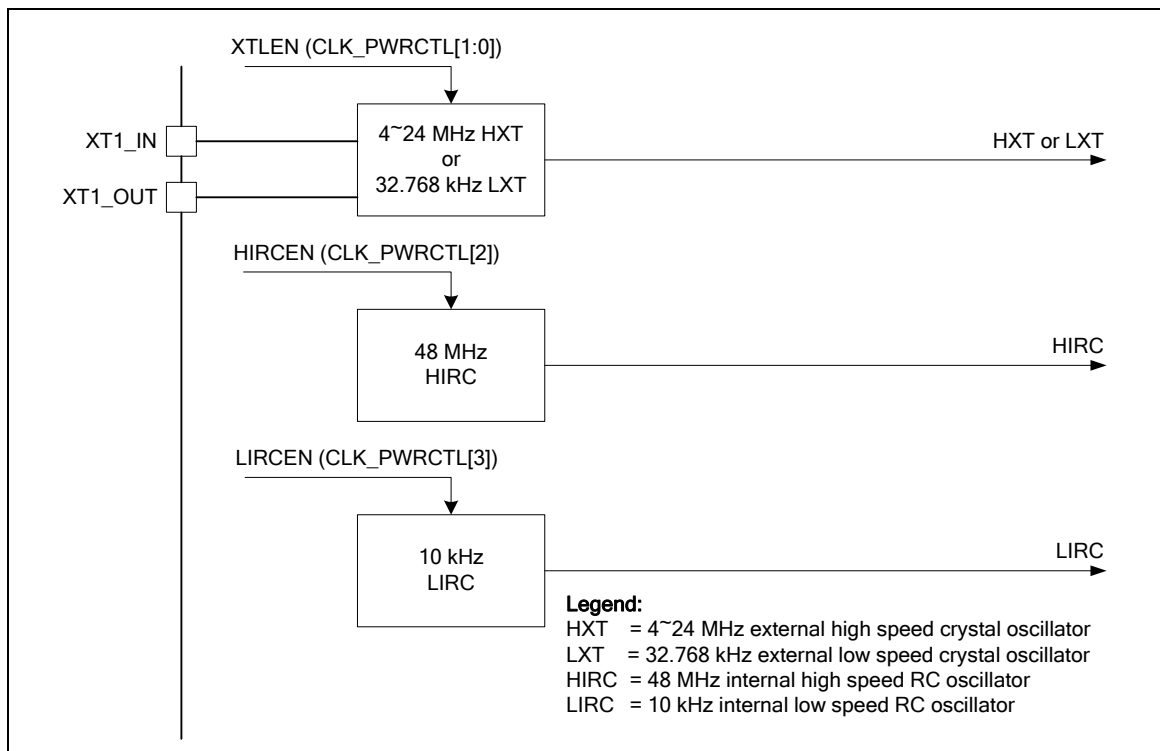

Figure 6.3-1 Clock Generator Block Diagram

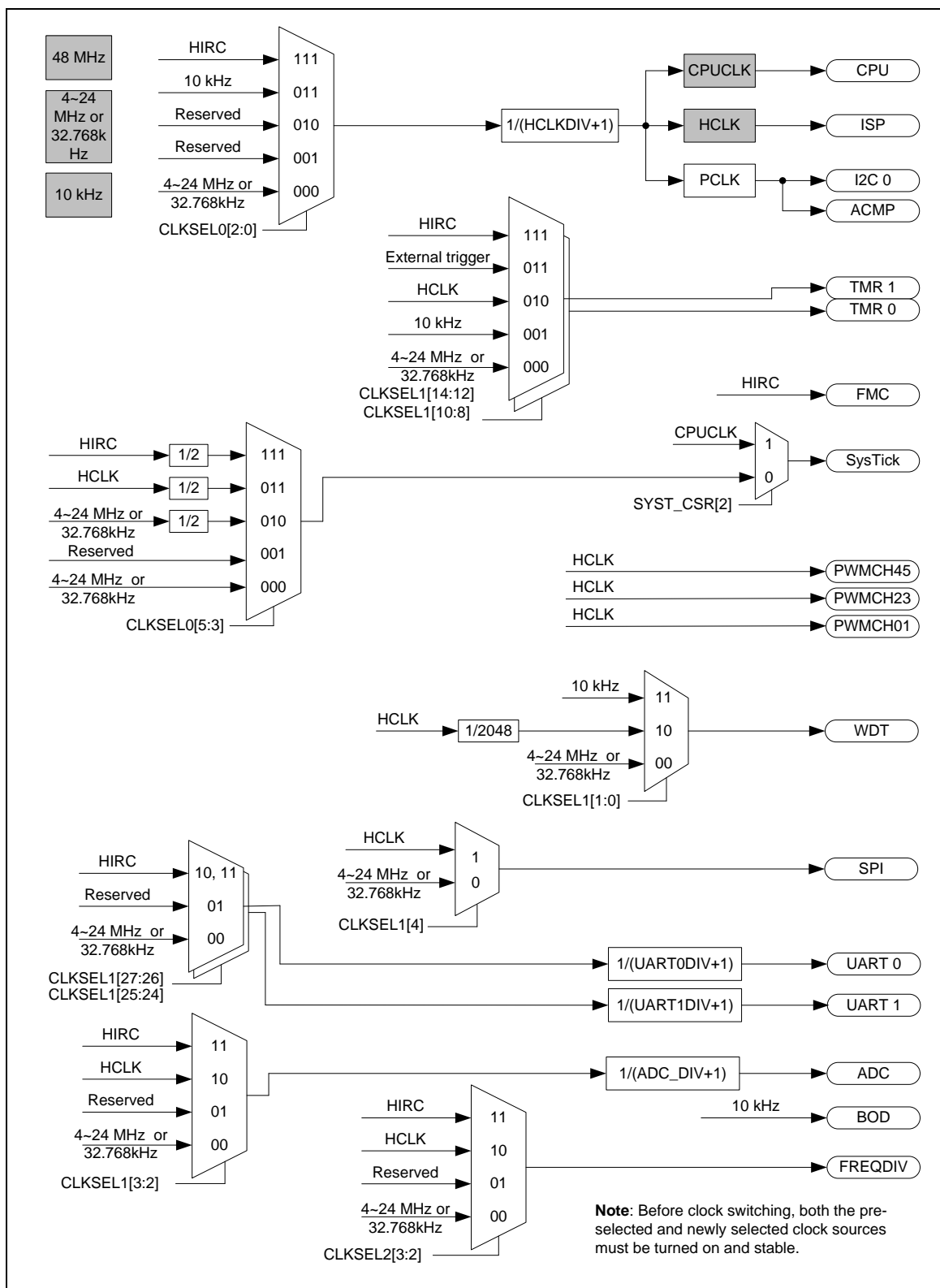

Figure 6.3-2 Clock Generator Global View Diagram

**Note:** Before clock switching, both the pre-selected and newly selected clock sources must be turned on and stable.

### 6.3.2 Auto-trim

This chip supports auto-trim function: the HIRC trim (22.1184 MHz internal RC oscillator), according to the accurate LXT (32.768 kHz crystal oscillator), automatically gets accurate HIRC output frequency, 1 % deviation within all temperature ranges. For instance, the system needs an accurate 22.1184 MHz clock. In such case, if users do not want to use 22.1184 MHz HXT as the system clock source, they need to solder 32.768 kHz crystal in system, and set FREQSEL (SYS\_IRCTCTL[0] trim frequency selection) to “1”, and the auto-trim function will be enabled. Interrupt status bit FREQLOCK (SYS\_IRCTISTS[0] HIRC frequency lock status) high indicates the HIRC output frequency is accurate within 1% deviation. To get better results, it is recommended to set both LOOPSEL (SYS\_IRCTCTL[5:4] trim calculation loop) and RETRYCNT (SYS\_IRCTCTL[7:6] trim value update limitation count) to “11”.

### 6.3.3 System Clock and SysTick Clock

The system clock has 4 clock sources which were generated from clock generator block. The clock source switch depends on the register HCLKSEL (CLK\_CLKSEL0[2:0]). The block diagram is shown in Figure 6.3-3.

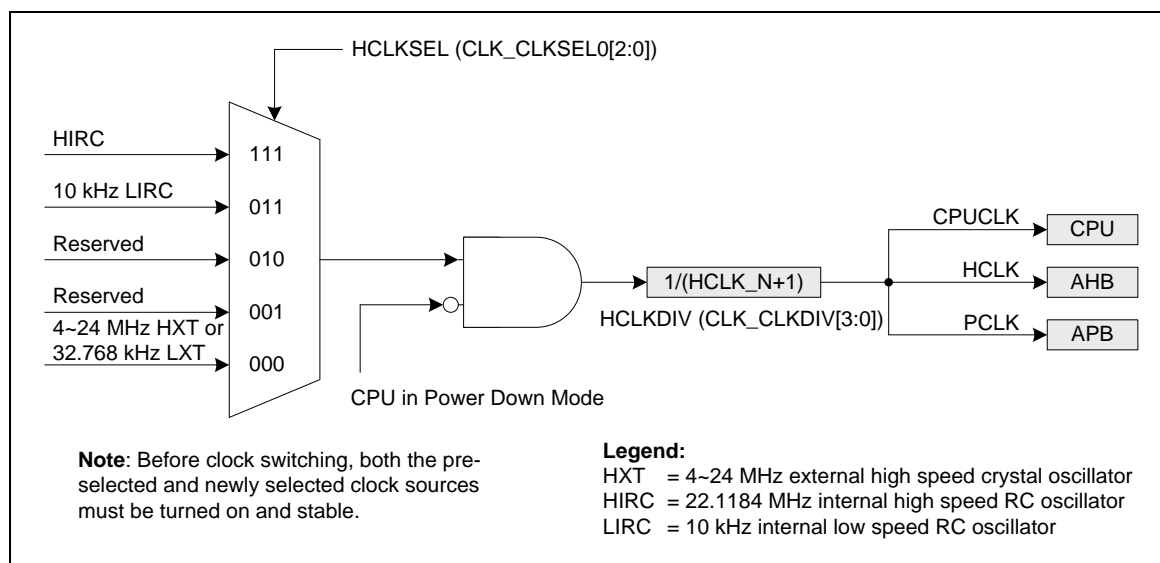

Figure 6.3-3 System Clock Block Diagram

The source of PCLK is equal to HCLK in system clock architecture.

The clock source of SysTick in Cortex®-M0 core can use CPU clock or external clock CLKSRC(SYST\_CSR[2]). If using external clock, the SysTick clock (STCLK) has 4 clock sources. The clock source switch depends on the setting of the register STCLKSEL (CLK\_CLKSEL0[5:3]). The block diagram is shown in Figure 6.3-4.

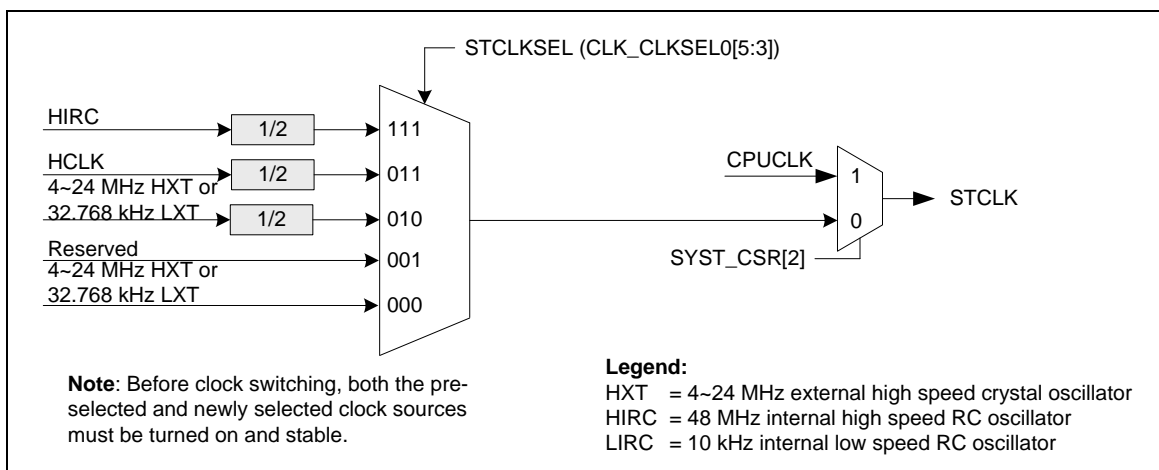

Figure 6.3-4 SysTick Clock Control Block Diagram

### 6.3.4 Peripherals Clock Source Selection

The peripheral clock has different clock source switch settings depending on different peripherals. Please refer to the CLK\_CLKSEL1 and CLK\_APBCLK register description in section 錯誤! 找不到參照來源。 . Please to note that, while switching clock source from one to another, user must wait until both clock sources are running stabled.

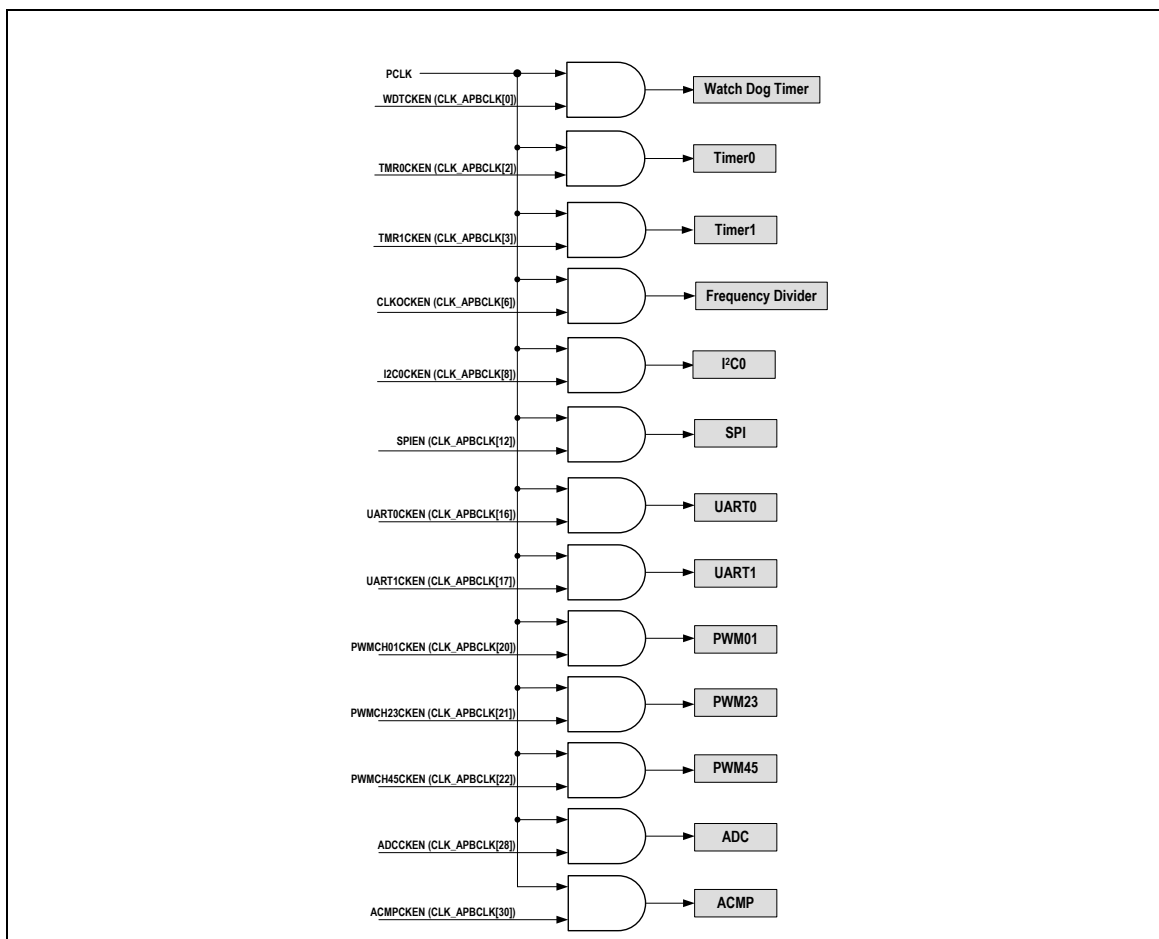

Figure 6.3-5 Peripherals Bus Clock Source Selection for PCLK

	Peripheral Clk Selectable	Ext. CLK (HXT Or LXT)	HIRC	LIRC	HCLK
WDT	Yes	Yes	No	Yes	Yes
Timer0	Yes	Yes	Yes	Yes	Yes
Timer1	Yes	Yes	Yes	Yes	Yes
I <sup>2</sup> C	No	-	-	-	-
SPI	Yes	Yes	No	No	Yes
UART0	Yes	Yes	Yes	No	No
UART1	Yes	Yes	Yes	No	No
PWM	No	-	-	-	-
ADC	Yes	Yes	Yes	No	Yes
ACMP	No	-	-	-	-

Table 6.3-1 Peripheral Clock Source Selection Table

**Note:** For the peripherals those peripheral clock are not selectable, its clock source is fixed to PCLK.

### 6.3.5 Power-down Mode Clock

When chip enters Power-down mode, system clocks, some clock sources, and some peripheral clocks will be disabled. Some clock sources and peripheral clocks are still active in Power-down mode.

The clocks still kept active are listed below:

- Clock Generator
- 10 kHz internal low speed oscillator (LIRC) clock
- 32.768 kHz external low speed crystal oscillator (LXT) clock (If PDLXT = 1 and XTLEN[1:0] = 10)
- Peripherals Clock (When 10 kHz low speed oscillator is adopted as clock source)
  - Watchdog Clock
  - Timer 0/1 Clock

### 6.3.6 Frequency Divider Output

This device is equipped with a power-of-2 frequency divider which is composed of 16 chained divide-by-2 shift registers. One of the 16 shift register outputs selected by a sixteen to one multiplexer is reflected to the CLKO pin. Therefore there are 16 options of power-of-2 divided clocks with the frequency from  $F_{in}/2^1$  to  $F_{in}/2^{16}$  where  $F_{in}$  is input clock frequency to the clock divider.

The output formula is  $F_{out} = F_{in}/2^{(N+1)}$ , where  $F_{in}$  is the input clock frequency,  $F_{out}$  is the clock divider output frequency and N is the 4-bit value in FREQSEL (CLK\_CLKOCTL[3:0]).

When writing 1 to CLKOEN (CLK\_CLKOCTL[4]), the chained counter starts to count. When writing 0 to CLKOEN (CLK\_CLKOCTL[4]), the chained counter continuously runs till divided clock reaches low state and stay in low state.

If DIV1EN (CLK\_CLKOCTL[5]) set to 1, the frequency divider clock (FRQDIV\_CLK) will bypass power-of-2 frequency divider. The frequency divider clock will be output to CLKO pin directly.

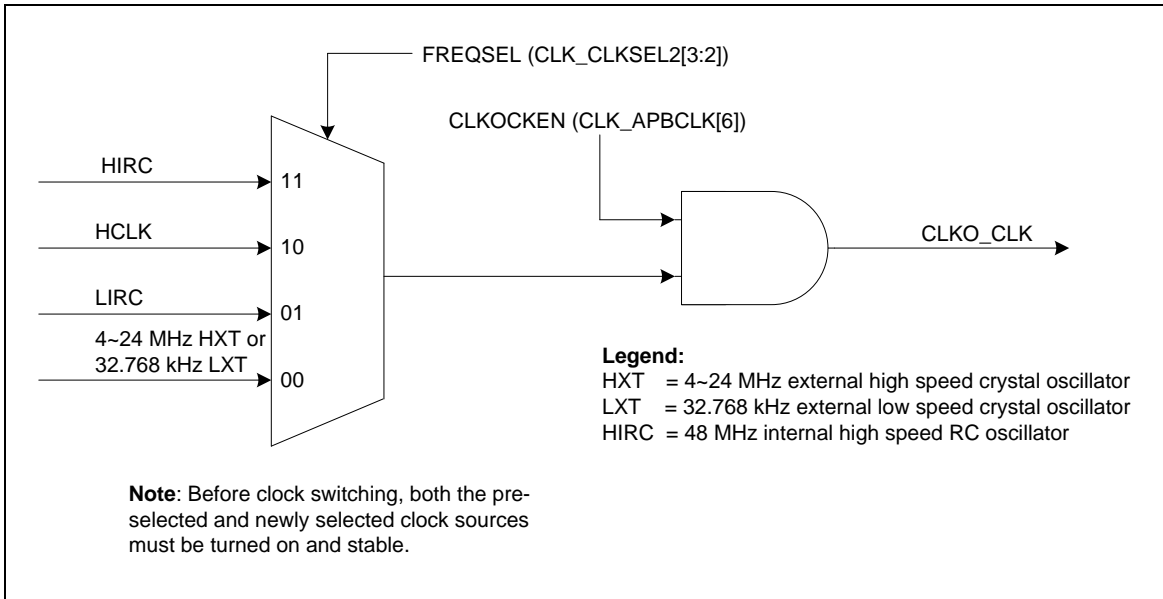

Figure 6.3-6 Clock Source of Frequency Divider

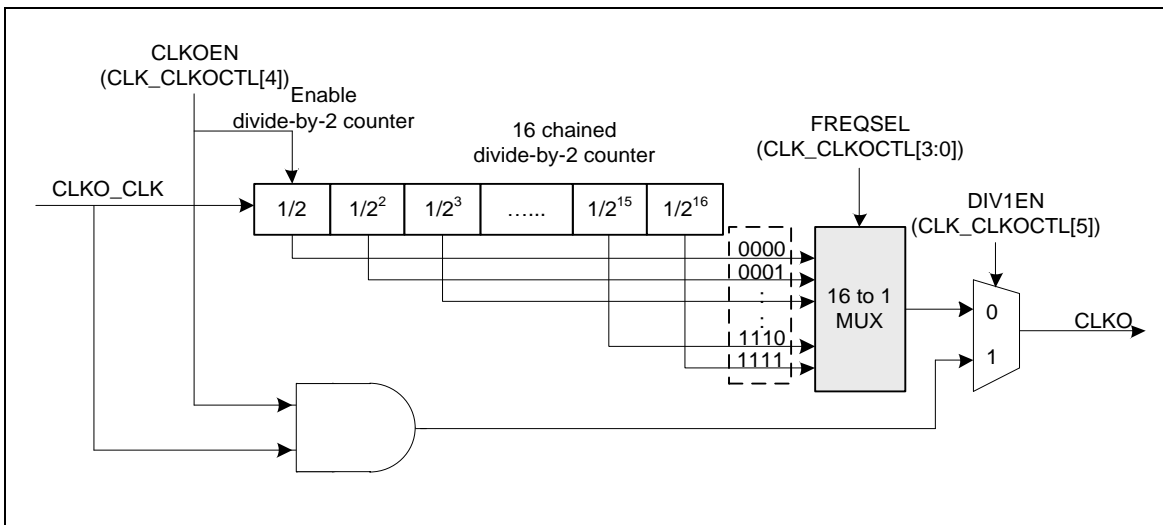

Figure 6.3-7 Block Diagram of Frequency Divider

## 6.4 Flash Memory Controller (FMC)

### 6.4.1 Overview

The NuMicro® NM1200/NM1100 series is equipped with 17.5 Kbytes on-chip embedded flash for application and Data Flash to store some application dependent data. A User Configuration block provides for system initialization. A 2 Kbytes loader ROM (LDROM) is used for In-System-Programming (ISP) function. This chip also supports In-Application-Programming (IAP) function, user switches the code executing without the chip reset after the embedded flash updated.

### 6.4.2 Features

- Supports 17.5 Kbytes application ROM (APROM).
- Supports 2 Kbytes loader ROM (LDROM).
- Supports configurable Data Flash size to share with APROM.
- Supports User Configuration block to control system initialization.
- Supports 512 bytes page erase for all embedded flash.
- Supports In-System-Programming (ISP) / In-Application-Programming (IAP) to update embedded flash memory.



## 6.5 General Purpose I/O (GPIO)

### 6.5.1 Overview

The NuMicro® NM1200/NM1100 series has up to 33 General Purpose I/O pins to be shared with other function pins depending on the chip configuration. These 33 pins are arranged in 6 ports named as P0, P1, P2, P3, P4 and P5. Each of the 33 pins is independent and has the corresponding register bits to control the pin mode function and data.

The I/O type of each pin can be configured by software individually as Input, Push-pull output, Open-drain output, or Quasi-bidirectional mode. After the chip is reset, the I/O mode of all pins is stay in input mode and each port data register Px\_DOUT[n] resets to 1. For Quasi-bidirectional mode, each I/O pin is equipped with a very weak individual pull-up resistor about 110 kΩ ~ 300 kΩ for V<sub>DD</sub> is from 5.0 V to 2.1 V.

### 6.5.2 Features

- Four I/O modes:
  - ◆ Quasi-bidirectional mode
  - ◆ Push-pull output
  - ◆ Open-drain output
  - ◆ Input-only with high impedance
- Quasi-bidirectional TTL/Schmitt trigger input mode selected by SYS\_Px\_MFP[23:16]
- I/O pin configured as interrupt source with edge/level setting
- I/O pin internal pull-up resistor enabled only in Quasi-bidirectional I/O mode
- Enabling the pin interrupt function will also enable the pin wake-up function
- High driver and high sink I/O mode support
- Configurable default I/O mode of all pins after reset by CIOINI (Config0[10]) setting
  - ◆ CIOINI = 0, all GPIO pins in Quasi-bidirectional mode after chip reset
  - ◆ CIOINI = 1, all GPIO pins in Input tri-state mode after chip reset

## 6.6 Timer Controller (TMR)

### 6.6.1 Overview

The Timer Controller includes two 32-bit timers, TMR0 and TMR1, allowing user to easily implement a timer control for applications. The timer can perform functions, such as frequency measurement, delay timing, clock generation, event counting by external input pins, and interval measurement by external capture pins.

### 6.6.2 Features

- Two sets of 32-bit timer with 24-bit up counter and one 8-bit prescale counter
- Independent clock source for each timer
- Provides one-shot, periodic, toggle-output and continuous counting operation modes
- 24-bit up counter value is readable through CNT (TIMRTx\_CNT[23:0])
- Supports event counting function
- 24-bit capture value is readable through CAPDAT (TIMERx\_CAP[23:0])
- Supports external capture pin event for interval measurement
- Supports external capture pin event to reset 24-bit up counter
- Supports chip wake-up from Idle/Power-down mode if a timer interrupt signal is generated
- Supports internal capture triggered while internal ACMP output signal transition

## 6.7 Enhanced PWM Generator (EPWM)

### 6.7.1 Overview

The NuMicro® NM1200/NM1100 series has built in one PWM unit (PWM0) which is specially designed for motor driving control applications. The PWM0 supports six PWM generators which can be configured as six independent PWM outputs, PWM0\_CH0~PWM0\_CH5, or as three complementary PWM pairs, (PWM0\_CH0, PWM0\_CH1), (PWM0\_CH2, PWM0\_CH3) and (PWM0\_CH4, PWM0\_CH5) with three programmable dead-time generators.

Every complementary PWM pairs share one 8-bit prescaler. There are six clock dividers providing five divided frequencies (1, 1/2, 1/4, 1/8, 1/16) for each channel. Each PWM output has independent 16-bit counter for PWM period control, and 16-bit comparators for PWM duty control. The six PWM generators provide twelve independent PWM interrupt flags which are set by hardware when the corresponding PWM period counter comparison matched period and duty. Each PWM interrupt source with its corresponding enable bit can request PWM interrupt. The PWM generators can be configured as One-shot mode to produce only one PWM cycle signal or Auto-reload mode to output PWM waveform continuously.

To prevent PWM driving output pin with unsteady waveform, the 16-bit period down counter and 16-bit comparator are implemented with double buffer. When user writes data to counter/comparator buffer registers, the updated value will be loaded into the 16-bit down counter/ comparator at the end of current period. The double buffering feature avoids glitch at PWM outputs.

Besides PWM, Motor controlling also need Timer, ACMP and ADC to work together. In order to control motor more precisely, we provide some registers that not only configure PWM but also Timer, ADC and ACMP, by doing so, it can save more CPU time and control motor with ease especially in BLDC.

### 6.7.2 Features

The PWM0 supports the following features:

- Six independent 16-bit PWM duty control units with maximum six port pins:
  - Six independent PWM outputs – PWM0\_CH0, PWM0\_CH1, PWM0\_CH2, PWM0\_CH3, PWM0\_CH4, and PWM0\_CH5
  - Three complementary PWM pairs, with each pin in a pair mutually complement to each other and capable of programmable dead-time insertion – (PWM0\_CH0, PWM0\_CH1), (PWM0\_CH2, PWM0\_CH3) and (PWM0\_CH4, PWM0\_CH5)
  - Three synchronous PWM pairs, with each pin in a pair in-phase – (PWM0\_CH0, PWM0\_CH1), (PWM0\_CH2, PWM0\_CH3) and (PWM0\_CH4, PWM0\_CH5)
- Group control bit – PWM0\_CH2 and PWM0\_CH4 are synchronized with PWM0\_CH0, PWM0\_CH3 and PWM0\_CH5 are synchronized with PWM0\_CH1
- One-shot (only support edge-aligned type) or Auto-reload mode PWM
- Up to 16-bit resolution
- Supports edge-aligned and center-aligned mode
- Supports asymmetric PWM generating in center-aligned mode
- Supports center loading in center-aligned mode
- Programmable dead-time insertion between complementary paired PWMs

- Each pin of PWM0\_CH0 to PWM0\_CH5 has independent polarity setting control
- Hardware fault brake protections
  - Supports software trigger
  - Two Interrupt source types:
    - Synchronously requested at PWM frequency when down counter comparison matched (edge- and center-aligned type) or underflow (edge-aligned type)
    - Requested when external fault brake asserted
      - ◆ BKP0: EINT0 or CPO1
      - ◆ BKP1: EINT1 or CPO0
- The PWM signals before polarity control stage are defined in the view of positive logic. The PWM ports is active high or active low are controlled by polarity control register
- Supports mask aligned function
- Supports independently rising CMP matching, PERIOD matching, falling CMP matching (in Center-aligned type), period matching to trigger ADC conversion
- Timer comparing matching event trigger PWM to do phase change in BLDC application
- Supports ACMP output event trigger PWM to force PWM output at most one period low, this feature is usually for step motor control
- Provides interrupt accumulation function

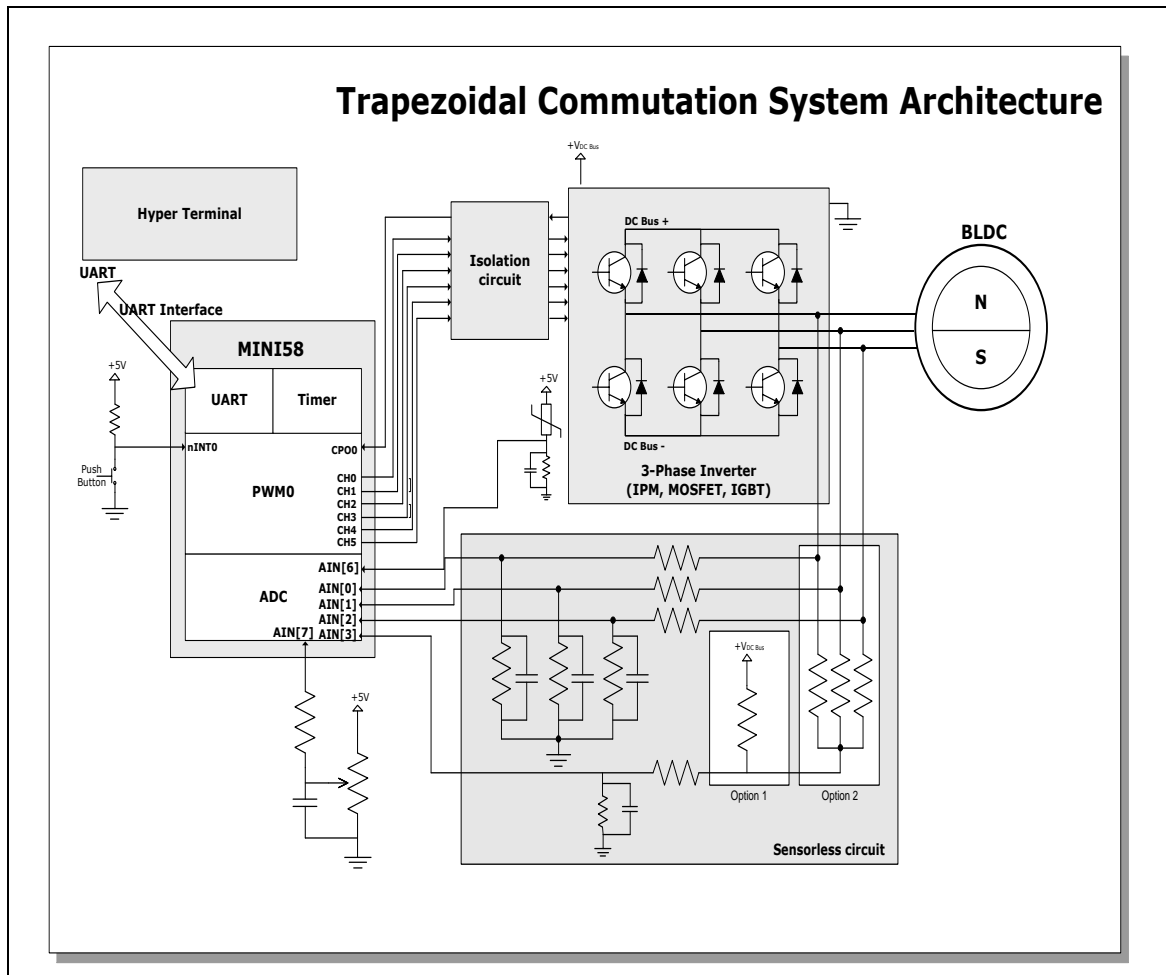

Figure 6.7-1 Application Circuit Diagram

## 6.8 Watchdog Timer (WDT)

### 6.8.1 Overview

The Watchdog Timer is used to perform a system reset when system runs into an unknown state. This prevents system from hanging for an infinite period of time. Besides, the Watchdog Timer supports the function to wake-up system from Idle/Power-down mode.

### 6.8.2 Features

- 18-bit free running up counter for WDT time-out interval
- Selectable time-out interval ( $2^4 \sim 2^{18}$ ) WDT\_CLK cycles and the time-out interval is 1.6 ms ~ 26.214s if WDT\_CLK = 10 kHz
- System kept in reset state for a period of  $(1 / \text{WDT\_CLK}) * 63$
- Supports WDT time-out wake-up function only if WDT clock source is selected as LIRC or LXT

## 6.9 UART Controller (UART)

### 6.9.1 Overview

The NuMicro® NM1200/NM1100 series provides two channels of Universal Asynchronous Receiver/Transmitters (UART). The UART0 performs supports flow control function. The UART0 performs a serial-to-parallel conversion on data received from the peripheral, and a parallel-to-serial conversion on data transmitted from the CPU. The UART0 controller also supports IrDA SIR Function, and RS-485 function mode. The UART0 channel supports six types of interrupts. The UART1 channel supports five types of interrupts. The UART1 only performs a serial-to-parallel conversion on data received from the peripheral, and a parallel-to-serial conversion on data transmitted from the CPU. The UART0 has 16 bytes Receiver/Transmitter FIFO. The UART1 has 4 bytes Receiver/Transmitter FIFO.

### 6.9.2 Features

- Full duplex, asynchronous communications
- Separates receive/transmit 16/16 bytes entry FIFO for data payloads (Only Available in UART0)
- Separates receive/transmit 4/4 byte buffer for data payloads (Only Available in UART1)
- Supports hardware auto flow control/flow control function (CTS, RTS) and programmable RTS flow control trigger level (Only Available in UART0)
- Programmable receiver buffer trigger level
- Supports programmable baud-rate generator for each channel individually
- Supports CTS wake-up function (Only Available in UART0)
- Supports 8-bit receiver buffer time-out detection function
- Programmable transmitting data delay time between the last stop and the next start bit by setting UART\_TOUT[15:8] register
- Supports break error, frame error, parity error and receive/transmit buffer overflow detection function
- Fully programmable serial-interface characteristics
  - Programmable number of data bit, 5, 6, 7, 8 character
  - Programmable parity bit, even, odd, no parity or stick parity bit generation and detection
  - Programmable stop bit, 1, 1.5, or 2 stop bit generation
- Supports IrDA SIR function mode (Only Available in UART0)
  - Supports 3/16-bit duration for normal mode
- Supports RS-485 function mode (Only Available in UART0)
  - Supports RS-485 9-bit mode
  - Supports hardware or software enable to program RTS pin to control RS-485 transmission direction directly

## 6.10 I<sup>2</sup>C Serial Interface Controller (I<sup>2</sup>C)

### 6.10.1 Overview

I<sup>2</sup>C is a two-wire, bi-directional serial bus that provides a simple and efficient method for data exchange between devices. The I<sup>2</sup>C standard is a true multi-master bus including collision detection and arbitration that prevents data corruption if two or more masters attempt to control the bus simultaneously.

### 6.10.2 Features

The I<sup>2</sup>C bus uses two wires (SDA and SCL) to transfer information between devices connected to the bus. The main features of the bus include:

- Master/Slave mode
- Bi-directional data transfer between masters and slaves
- Multi-master bus
- Arbitration between simultaneously transmitting masters without corruption of serial data on the bus
- Serial clock synchronization allowing devices with different bit rates to communicate via one serial bus
- Serial clock synchronization can be used as a handshake mechanism to suspend and resume serial transfer
- Built-in 14-bit time-out counter that requests the I<sup>2</sup>C interrupt if the I<sup>2</sup>C bus hangs up and timer-out counter overflows
- Programmable clocks allowing for versatile rate control
- Supports 7-bit addressing mode
- Supports multiple address recognition (four slave address registers with mask option)
- Supports Power-down wake-up function
- Supports two-level buffer function



## 6.11 Serial Peripheral Interface (SPI)

### 6.11.1 Overview

The Serial Peripheral Interface (SPI) applies to synchronous serial data communication and allows full duplex transfer. Devices communicate in Master/Slave mode with 4-wire bi-direction interface. The SPI controller performing a serial-to-parallel conversion on data received from a peripheral device, and a parallel-to-serial conversion on data transmitted to a peripheral device. SPI controller can be configured as a master or a slave device.

### 6.11.2 Features

- Supports Master or Slave mode operation
- Configurable transfer bit length
- Provides four 32-bit FIFO buffers
- Supports MSB first or LSB first transfer
- Supports byte reorder function
- Supports byte or word suspend mode
- Supports Slave 3-wire mode

## 6.12 Analog-to-Digital Converter (ADC)

### 6.12.1 Overview

The NM1200/NM1100 series contains one 10-bit successive approximation analog-to-digital converters (SAR A/D converter) with 12 input channels. The A/D converters can be started by software, external pin (STADC/P3.2) or PWM trigger.

### 6.12.2 Features

- Analog input voltage range: 0 ~ Analog Supply Voltage from AV<sub>DD</sub>
- 10-bit resolution and 8-bit accuracy is guaranteed
- Up to 12 single-end analog input channels
- Maximum ADC clock frequency is 8 MHz, and 18 ADC clocks per sample
- Two operating modes
  - ◆ Single mode: A/D conversion is performed one time on a specified channel
  - ◆ PWM sequence mode: When PWM trigger, two of three ADC channels from 0 to 2 will automatically convert analog data in the sequence of channel [0,1] or channel[1,2] or channel[0,2] defined by MODESEL (ADC\_SEQCTL[3:2])
- An A/D conversion can be started by:
  - ◆ Software write 1 to SWTRG bit
  - ◆ External pin STADC
  - ◆ PWM trigger with optional start delay period
- Each Conversion result is held in data register with valid and overrun indicators
- Conversion results can be compared with specified value and user can select whether to generate an interrupt when conversion result matches the compare register setting
- Channel 0 supports 2 input sources: External reference voltage (ADC\_VREF) and ADC input internal fixed band-gap voltage
- Channel 7 supports 2 input sources: internal fixed band-gap voltage and ADC input

## 6.13 Analog Comparator (ACMP)

### 6.13.1 Overview

The NuMicro® NM1200/NM1100 series contains two comparators which can be used in a number of different configurations. The comparator output is logic 1 when positive input is greater than negative input, otherwise the output is 0. Each comparator can be configured to generate interrupt when the comparator output value changes.

### 6.13.2 Features

- Analog input voltage range: 0 ~ AV<sub>DD</sub>
- Supports Hysteresis function
- Optional internal reference voltage source for each comparator negative input
- ACMP0 supports:
  - Four positive sources
    - P1.5, P1.0, P1.2, or P1.3
  - Three negative sources
    - P1.4
    - Internal Comparator Reference Voltage (CRV)
    - Internal band-gap voltage (V<sub>BG</sub>)
- ACMP1 supports:
  - Four positive sources
    - P3.1, P3.2, P3.4, or P3.5
  - Three negative sources
    - P3.0
    - Internal Comparator Reference Voltage (CRV)
    - Internal band-gap voltage (V<sub>BG</sub>)

## 6.14 Hardware Divider (HDIV)

### 6.14.1 Overview

The hardware divider (HDIV) is useful to the high performance application. The hardware divider is a signed, integer divider with both quotient and remainder outputs.

### 6.14.2 Features

- Signed (two's complement) integer calculation
- 32-bit dividend with 16-bit divisor calculation capacity
- 32-bit quotient and 32-bit remainder outputs (16-bit remainder with sign extends to 32-bit)
- Divided by zero warning flag
- 6 HCLK clocks taken for one cycle calculation
- Write divisor to trigger calculation
- Waiting for calculation ready automatically when reading quotient and remainder

7 APPLICATION CIRCUIT

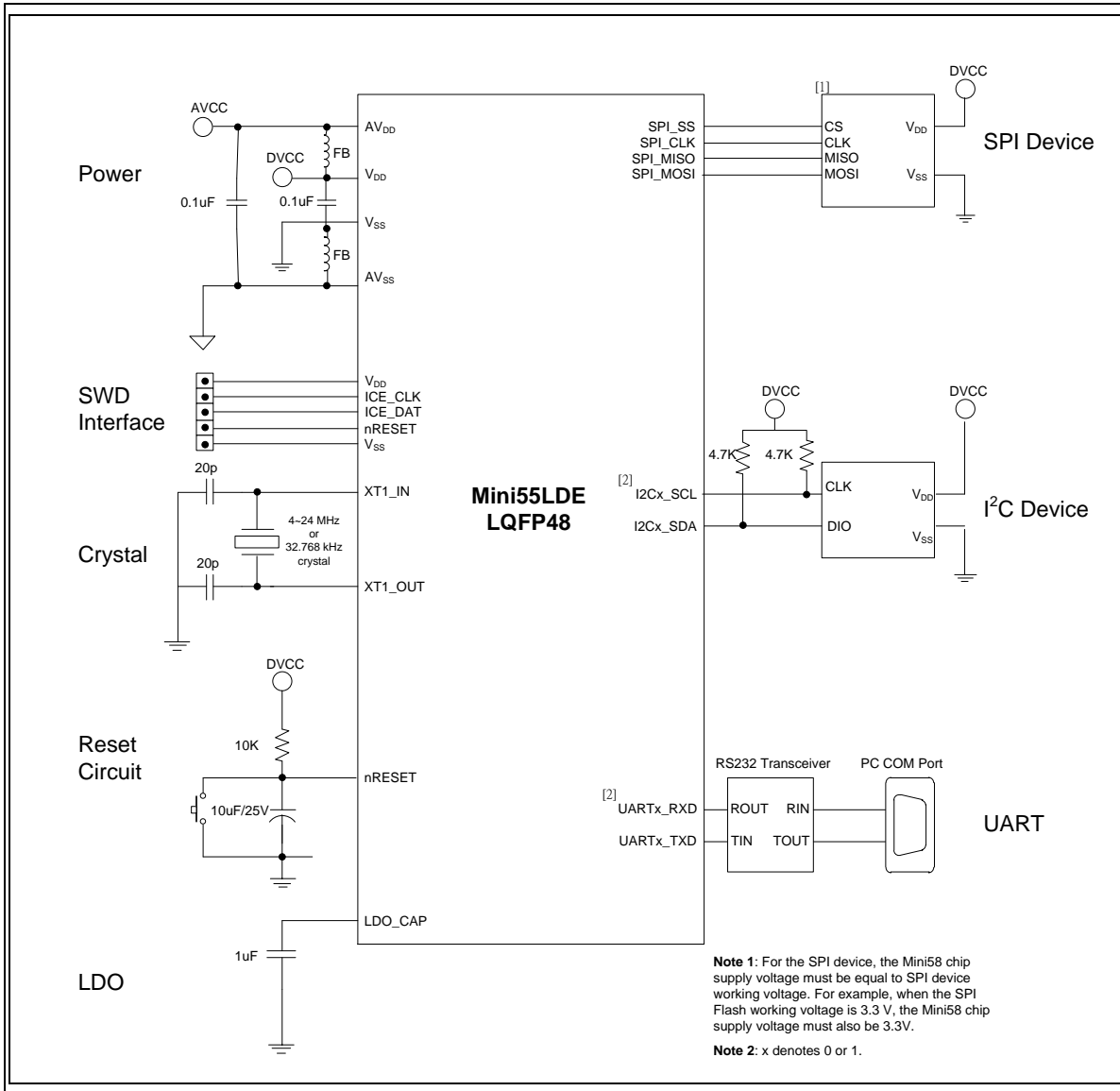

## 8 ELECTRICAL CHARACTERISTICS

### 8.1 Absolute Maximum Ratings

Symbol	Parameter	Min	Max	Unit
$V_{DD} - V_{SS}$	DC Power Supply	-0.3	+7.0	V
$V_{IN}$	Input Voltage	$V_{SS} - 0.3$	$V_{DD} + 0.3$	V
$1/t_{CLCL}$	Oscillator Frequency	4	24	MHz
$T_A$	Operating Temperature	-40	+105	°C
$T_{ST}$	Storage Temperature	-55	+150	°C
$I_{DD}$	Maximum Current into $V_{DD}$	-	120	mA
$I_{SS}$	Maximum Current out of $V_{SS}$	-	120	mA
$I_{IO}$	Maximum Current sunk by an I/O pin	-	35	mA
	Maximum Current sourced by an I/O pin	-	35	mA
	Maximum Current sunk by total I/O pins	-	100	mA
	Maximum Current sourced by total I/O pins	-	100	mA

Note: Exposure to conditions beyond those listed under absolute maximum ratings may adversely affects the life and reliability of the device.

### 8.2 DC Electrical Characteristics

( $V_{DD} - V_{SS} = 2.5 \sim 5.5$  V,  $T_A = 25^\circ\text{C}$ )

Symbol	Parameter	Min	Typ	Max	Unit	Test Conditions			
$V_{DD}$	Operation voltage	2.5	-	5.5	V	$V_{DD} = 2.5\text{V} \sim 5.5\text{V}$ up to 48 MHz			
$V_{SS} / AV_{SS}$	Power Ground	-0.3	-	-	V				
$V_{LDO}$	LDO Output Voltage	1.62	1.8	1.98	V	$V_{DD} \geq 2.5$ V			
$V_{BG}$	Band-gap Voltage		1.2		V	$V_{DD} = 3.0\text{V} \sim 5.5\text{V}$ , $T_A = -40^\circ\text{C} \sim 105^\circ\text{C}$			
$V_{DD} - AV_{DD}$	Allowed Voltage Difference for $V_{DD}$ and $AV_{DD}$	-0.3	0	0.3	V	-			
$I_{DD5}$	Operating Current Normal Run Mode	-	17	-	mA	$V_{DD}$	HXT	HIRC	All Digital Modules
						5.5V	X	V	V
$I_{DD6}$	HCLK =48 MHz	-	12	-	mA	5.5V	X	V	X
$I_{DD7}$	while(1){ Executed from Flash	-	17	-	mA	3.3V	X	V	V
$I_{DD8}$		-	12	-	mA	3.3V	X	V	X
$I_{DD5}$	Operating Current Normal Run Mode	-	16	-	mA	$V_{DD}$	HXT	HIRC	All Digital Modules
						5.5V	X	V	V
$I_{DD6}$	HCLK =44.2368 MHz	-	11	-	mA	5.5V	X	V	X
$I_{DD7}$	while(1){ Executed from Flash	-	16	-	mA	3.3V	X	V	V
$I_{DD8}$		-	11	-	mA	3.3V	X	V	X
$I_{DD5}$	Operating Current Normal Run Mode	-	10.5	-	mA	$V_{DD}$	HXT	HIRC	All Digital Modules
						5.5V	X	V	V
$I_{DD6}$	HCLK =24 MHz	-	7.5	-	mA	5.5V	X	V	X
$I_{DD7}$	while(1){ Executed from Flash	-	10.5	-	mA	3.3V	X	V	V
$I_{DD8}$		-	7.5	-	mA	3.3V	X	V	X
$I_{DD5}$	Operating Current Normal Run Mode	-	9.5	-	mA	$V_{DD}$	HXT	HIRC	All Digital Modules
						5.5V	X	V	V
$I_{DD6}$	HCLK =22.1184 MHz	-	6.5	-	mA	5.5V	X	V	X
$I_{DD7}$	while(1){ Executed from Flash	-	9.5	-	mA	3.3V	X	V	V

I <sub>DD8</sub>		-	6.5	-	mA	3.3V	X	V	X
I <sub>DD1</sub>	Operating Current Normal Run Mode	-	8.0	-	mA	V <sub>DD</sub>	HXT	HIRC	All Digital Modules
						5.5V	24 MHz	X	V
I <sub>DD2</sub>	HCLK = 24 MHz	-	6.5	-	mA	5.5V	24 MHz	X	X
I <sub>DD3</sub>	while(1){ Executed from Flash	-	8.0	-	mA	3.3V	24 MHz	X	V
I <sub>DD4</sub>		-	6.5	-	mA	3.3V	24 MHz	X	X
I <sub>DD9</sub>	Operating Current Normal Run Mode	-	4.5	-	mA	V <sub>DD</sub>	HXT	HIRC	All Digital Modules
						5.5V	12 MHz	X	V
I <sub>DD10</sub>	HCLK = 12MHz	-	3.5	-	mA	5.5V	12 MHz	X	X
I <sub>DD11</sub>	while(1){ Executed from Flash	-	4.5	-	mA	3.3V	12 MHz	X	V
I <sub>DD12</sub>		-	3.5	-	mA	3.3V	12 MHz	X	X
I <sub>DD13</sub>	Operating Current Normal Run Mode	-	2.0	-	mA	V <sub>DD</sub>	HXT	HIRC	All Digital Modules
						5.5V	4 MHz	X	V
I <sub>DD14</sub>	HCLK = 4 MHz	-	1.6	-	mA	5.5V	4 MHz	X	X
I <sub>DD15</sub>	while(1){ Executed from Flash	-	2.0	-	mA	3.3V	4 MHz	X	V
I <sub>DD16</sub>		-	1.6	-	mA	3.3V	4 MHz	X	X
I <sub>DD17</sub>	Operating Current Normal Run Mode	-	100	-	μA	V <sub>DD</sub>	HXT	LIRC	All Digital Modules
						5.5V	X	V	V <sup>(4)</sup>
I <sub>DD18</sub>	HCLK = 10 kHz	-	100	-	μA	5.5V	X	V	X
I <sub>DD19</sub>	while(1){ Executed from Flash	-	90	-	μA	3.3V	X	V	V <sup>(4)</sup>
I <sub>DD20</sub>		-	90	-	μA	3.3V	X	V	X
I <sub>IDLE5</sub>	Operating Current	-	10	-	mA	V <sub>DD</sub>	HXT	HIRC	All Digital Modules
						5.5V	X	V	V
I <sub>IDLE6</sub>	Idle Mode	-	5	-	mA	5.5V	X	V	X
I <sub>IDLE7</sub>	HCLK=48 MHz	-	10	-	mA	3.3V	X	V	V
I <sub>IDLE8</sub>		-	5	-	mA	3.3V	X	V	X
I <sub>IDLE5</sub>	Operating Current	-	9.5	-	mA	V <sub>DD</sub>	HXT	HIRC	All Digital Modules



	Idle Mode					5.5V	X	V	V
I <sub>IDLE6</sub>	HCLK=44.2368 MHz	-	4.5	-	mA	5.5V	X	V	X
I <sub>IDLE7</sub>		-	9.5	-	mA	3.3V	X	V	V
I <sub>IDLE8</sub>		-	4.5	-	mA	3.3V	X	V	X
I <sub>IDLE5</sub>		Operating Current	-	6.5	-	mA	V <sub>DD</sub>	HXT	HIRC
						5.5V	X	V	V
I <sub>IDLE6</sub>	Idle Mode	-	3.5	-	mA	5.5V	X	V	X
I <sub>IDLE7</sub>	HCLK=24 MHz	-	6.5	-	mA	3.3V	X	V	V
I <sub>IDLE8</sub>			-	3.5	-	mA	3.3V	X	V
I <sub>IDLE5</sub>	Operating Current	-	6.0	-	mA	V <sub>DD</sub>	HXT	HIRC	All Digital Modules
						5.5V	X	V	V
I <sub>IDLE6</sub>	Idle Mode	-	3.0	-	mA	5.5V	X	V	X
I <sub>IDLE7</sub>	HCLK=22.1184 MHz	-	6.0	-	mA	3.3V	X	V	V
I <sub>IDLE8</sub>			-	3.0	-	mA	3.3V	X	V
I <sub>IDLE1</sub>	Operating Current	-	4.0	-	mA	V <sub>DD</sub>	HXT	HIRC	All Digital Modules
						5.5V	24 MHz	X	V
I <sub>IDLE2</sub>	Idle Mode	-	2.2	-	mA	5.5V	24 MHz	X	X
I <sub>IDLE3</sub>	HCLK = 24MHz	-	4.0	-	mA	3.3V	24 MHz	X	V
I <sub>IDLE4</sub>			-	2.2	-	mA	3.3V	24 MHz	X
I <sub>IDLE9</sub>	Operating Current	-	2.5	-	mA	V <sub>DD</sub>	HXT	HIRC	All Digital Modules
						5.5V	V	X	V
I <sub>IDLE10</sub>	Idle Mode	-	1.5	-	mA	5.5V	V	X	X
I <sub>IDLE11</sub>	HCLK = 12 MHz	-	2.5	-	mA	3.3V	V	X	V
I <sub>IDLE12</sub>			-	1.5	-	mA	3.3V	V	X
I <sub>IDLE13</sub>	Operating Current Idle Mode	-	1.5	-	mA	V <sub>DD</sub>	HXT	HIRC	All Digital Modules
						5.5V	V	X	V
I <sub>IDLE14</sub>	HCLK = 4 MHz	-	1.0	-	mA	5.5V	V	X	X

I <sub>IDLE15</sub>		-	1.5	-	mA	3.3V	V	X	V
I <sub>IDLE16</sub>		-	1.0	-	mA	3.3V	V	X	X
I <sub>DD17</sub>	Operating Current Idle Mode HCLK = 10 kHz	-	90	-	μA	V <sub>DD</sub>	HXT	LIRC	All Digital Modules
I <sub>DD18</sub>		-	90	-	μA	5.5V	X	V	V <sup>[4]</sup>
I <sub>DD19</sub>		-	80	-	μA	3.3V	X	V	V <sup>[4]</sup>
I <sub>DD20</sub>		-	80	-	μA	3.3V	X	V	X
I <sub>PWD1</sub>	Standby Current Power-down Mode (Deep Sleep Mode)	-	1.5	-	μA	V <sub>DD</sub> = 5.5 V, All oscillators and analog blocks turned off.			
I <sub>PWD2</sub>		-	1.4	-	μA	V <sub>DD</sub> = 3.3 V, All oscillators and analog blocks turned off.			
I <sub>IL</sub>	Logic 0 Input Current P0/1/2/3/4/5 (Quasi-bidirectional Mode)	-		-75	μA	V <sub>DD</sub> = 5.5 V, V <sub>IN</sub> = 0V			
I <sub>TL</sub>	Logic 1 to 0 Transition Current P0/1/2/3/4/5 (Quasi-bidirectional Mode) [*3]	-		-750	μA	V <sub>DD</sub> = 5.5 V, V <sub>IN</sub> = 2.0V			
I <sub>LK</sub>	Input Leakage Current P0/1/2/3/4	-1	-	+1	μA	V <sub>DD</sub> = 5.5 V, 0 < V <sub>IN</sub> < V <sub>DD</sub> Open-drain or input only mode			
V <sub>IL1</sub>	Input Low Voltage P0/1/2/3/4 (TTL Input)	-0.3	-	0.8	V	V <sub>DD</sub> = 4.5 V			
		-0.3	-	0.6		V <sub>DD</sub> = 2.5 V			
V <sub>IH1</sub>	Input High Voltage P0/1/2/3/4 (TTL Input)	2.0	-	V <sub>DD</sub> + 0.3	V	V <sub>DD</sub> = 5.5 V			
		1.5	-	V <sub>DD</sub> + 0.3		V <sub>DD</sub> = 3.0 V			
V <sub>IL3</sub>	Input Low Voltage XTAL1[*2]	0	-	0.8	V	V <sub>DD</sub> = 4.5 V			
		0	-	0.4		V <sub>DD</sub> = 2.5 V			
V <sub>IH3</sub>	Input High Voltage XTAL1[*2]	3.5	-	V <sub>DD</sub> + 0.3	V	V <sub>DD</sub> = 5.5 V			
		2.4	-	V <sub>DD</sub> + 0.3		V <sub>DD</sub> = 3.0 V			
V <sub>ILS</sub>	Negative-going Threshold (Schmitt Input), nRESET	-0.3	-	0.2 V <sub>DD</sub>	V	-			
V <sub>IHS</sub>	Positive-going Threshold (Schmitt Input), nRESET	0.7 V <sub>DD</sub>	-	V <sub>DD</sub> + 0.3	V	-			
R <sub>RST</sub>	Internal nRESET Pin Pull-up Resistor	17.5		150	kΩ	V <sub>DD</sub> = 2.1 V ~ 5.5V			

$V_{ILS}$	Negative-going Threshold (Schmitt input), P0/1/2/3/4/5	-0.3	-	$0.3 V_{DD}$	V	-
$V_{IHS}$	Positive-going Threshold (Schmitt input), P0/1/2/3/4/5	$0.7 V_{DD}$	-	$V_{DD} + 0.3$	V	-
$I_{SR11}$	Source Current P0/1/2/3/4/5 (Quasi-bidirectional Mode)	-300	-400	-	$\mu A$	$V_{DD} = 4.5 V, V_S = 2.4 V$
$I_{SR12}$		-50	-80	-	$\mu A$	$V_{DD} = 2.7 V, V_S = 2.2 V$
$I_{SR13}$		-40	-73	-	$\mu A$	$V_{DD} = 2.5 V, V_S = 2.0 V$
$I_{SR21}$	Source Current P0/1/2/3/4/5 (Push-pull Mode)	-20	-26	-	mA	$V_{DD} = 4.5 V, V_S = 2.4 V$
$I_{SR22}$		-3	-5	-	mA	$V_{DD} = 2.7 V, V_S = 2.2 V$
$I_{SR23}$		-2.5	-5	-	mA	$V_{DD} = 2.5 V, V_S = 2.0 V$
$I_{SK11}$	Sink Current P0/1/2/3/4/5 (Quasi-bidirectional, Open-Drain and Push-pull Mode)	10	15	-	mA	$V_{DD} = 4.5 V, V_S = 0.45 V$
$I_{SK12}$		6	9	-	mA	$V_{DD} = 2.7 V, V_S = 0.45 V$
$I_{SK13}$		5	8	-	mA	$V_{DD} = 2.5 V, V_S = 0.45 V$

Notes:

1. nRST pin is a Schmitt trigger input.
2. XTAL1 is a CMOS input.
3. Pins of P0, P1, P2, P3, P4 and P5 can source a transition current when they are being externally driven from 1 to 0. In the condition of  $V_{DD}=5.5V$ , the transition current reaches its maximum value when  $V_{IN}$  approximates to 2V.
4. Only enable modules which support 10 kHz LIRC clock source

### 8.3 AC Electrical Characteristics

#### 8.3.1 External Input Clock

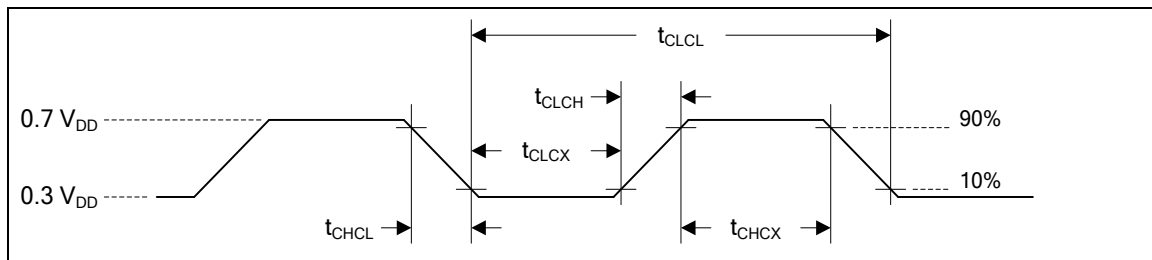

Note: Duty cycle is 50%.

Symbol	Parameter	Min	Typ	Max	Unit	Test Conditions
t <sub>CHCX</sub>	Clock High Time	10	-	-	ns	-
t <sub>CLCX</sub>	Clock Low Time	10	-	-	ns	-
t <sub>CLCH</sub>	Clock Rise Time	2	-	15	ns	-
t <sub>CHCL</sub>	Clock Fall Time	2	-	15	ns	-

#### 8.3.2 External 4~24 MHz High Speed Crystal (HXT)

Symbol	Parameter	Min.	Typ.	Max	Unit	Test Conditions
V <sub>HXT</sub>	Operation Voltage	2.5	-	5.5	V	-
T <sub>A</sub>	Temperature	-40	-	105	°C	-
I <sub>HXT</sub>	Operating Current	-	410	-	uA	12 MHz, V <sub>DD</sub> = 5.5V
f <sub>HXT</sub>	Clock Frequency	4	-	24	MHz	-

#### 8.3.3 Typical Crystal Application Circuits

Crystal	C1	C2
4 MHz ~ 24 MHz	10~20 pF	10~20 pF

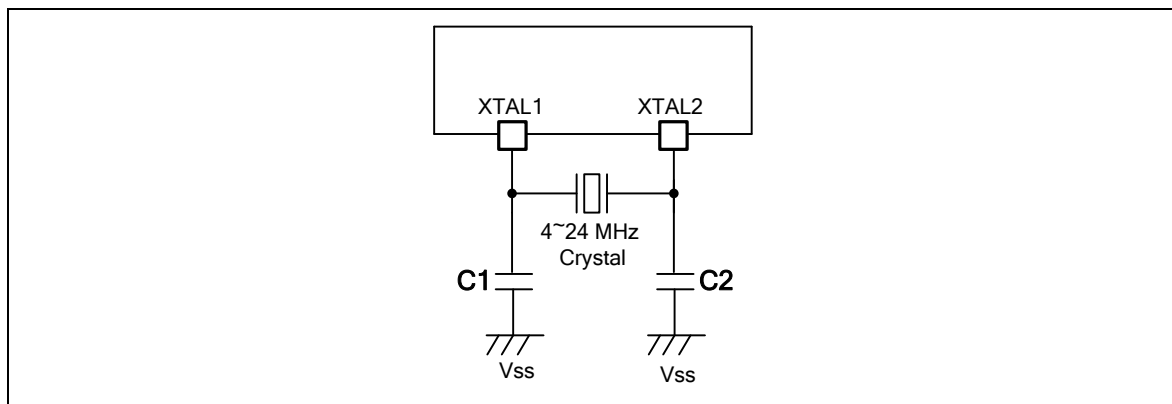

Figure 8-1 NM1200/NM1100 Typical Crystal Application Circuit

### 8.3.4 48 MHz Internal High Speed RC Oscillator (HIRC)

Symbol	Parameter	Min	Typ	Max	Unit	Test Conditions
$V_{HRC}$	Supply Voltage	1.62	1.8	1.98	V	-
$f_{HRC}$	Center Frequency	-	48	-	MHz	-
	Calibrated Internal Oscillator Frequency	-1	-	+1	%	$T_A = 25^\circ\text{C}$ $V_{DD} = 5\text{ V}$
		-3 <sup>[1]</sup>	-	+3 <sup>[1]</sup>	%	$T_A = -40^\circ\text{C} \sim 105^\circ\text{C}$ $V_{DD} = 2.5\text{ V} \sim 5.5\text{ V}$
$I_{HRC}$	Operating Current	-	700	-	$\mu\text{A}$	$T_A = 25^\circ\text{C}, V_{DD} = 5\text{ V}$

**Note1:** These parameters are characterized but not tested.

### 8.3.5 10 kHz Internal Low Speed RC Oscillator (LIRC)

Symbol	Parameter	Min	Typ	Max	Unit	Test Conditions
$V_{LRC}$	Supply Voltage	2.5	-	5.5	V	-
$f_{LRC}$	Center Frequency	-	10	-	kHz	-
	Oscillator Frequency	-50 <sup>[1]</sup>	-	+50 <sup>[1]</sup>	%	$V_{DD} = 2.1\text{ V} \sim 5.5\text{ V}$ $T_A = -40^\circ\text{C} \sim +105^\circ\text{C}$

**Note1:** These parameters are characterized but not tested.

## 8.4 Analog Characteristics

### 8.4.1 10-bit SAR ADC

Symbol	Parameter	Min	Typ	Max	Unit	Test Condition
-	Resolution	-	-	10	Bit	-
DNL	Differential Nonlinearity Error	-	-1~1.5	-1~+3	LSB	-
INL	Integral Nonlinearity Error	-	±1	±2	LSB	-
E <sub>o</sub>	Offset Error	-	1	2	LSB	-
E <sub>G</sub>	Gain Error (Transfer Gain)	-	-1	-1.5	LSB	-
E <sub>A</sub>	Absolute Error	-	3	5	LSB	-
-	Monotonic	Guaranteed			-	-
F <sub>ADC</sub>	ADC Clock Frequency	-	-	8	MHz	AV <sub>DD</sub> = 4.5~5.5 V
		-	-	5.4		AV <sub>DD</sub> = 2.5~5.5 V
F <sub>S</sub>	Sample Rate (F <sub>ADC</sub> /T <sub>CONV</sub> )	-	-	500	kSPS	AV <sub>DD</sub> = 4.5~5.5 V
		-	-	300	kSPS	AV <sub>DD</sub> = 2.5~5.5 V
T <sub>ACQ</sub>	Acquisition Time (Sample Stage)	N+1			1/F <sub>ADC</sub>	N is sampling counter, N=6,7,8,10,14,22,38,70,134,262,1030
T <sub>CONV</sub>	Total Conversion Time	N+12			1/F <sub>ADC</sub>	
AV <sub>DD</sub>	Supply Voltage	2.5	-	5.5	V	-
I <sub>DDA</sub>	Supply Current (Avg.)	-	200	-	μA	AV <sub>DD</sub> = 5.5 V
V <sub>IN</sub>	Analog Input Voltage	0	-	AV <sub>DD</sub>	V	-
C <sub>IN</sub>	Input Capacitance	-	12	-	pF	-
R <sub>IN</sub>	Input Load	-	7	-	kΩ	-

Note: ADC voltage reference is same with AV<sub>DD</sub>

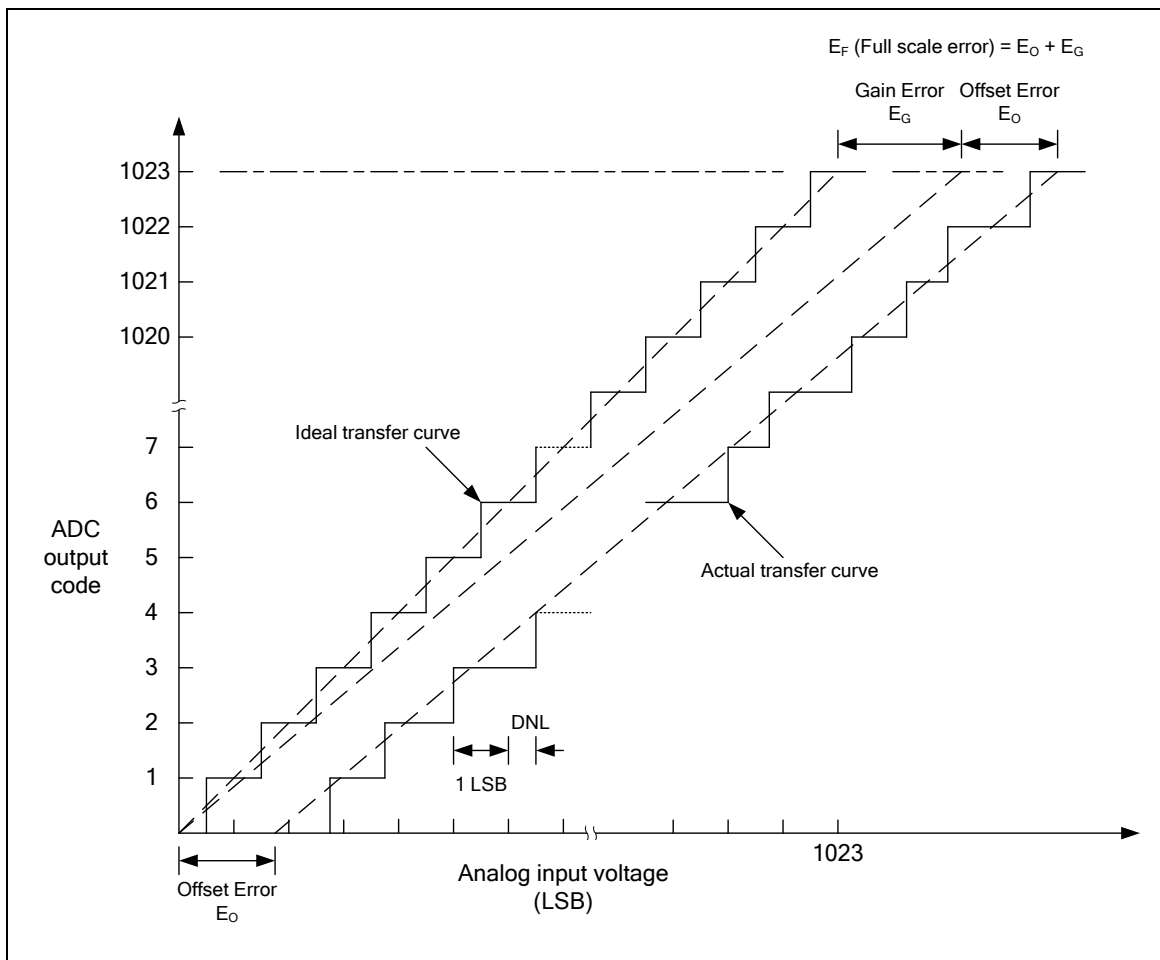

### 8.4.2 LDO & Power Management

Symbol	Parameter	Min	Typ	Max	Unit	Test Condition
V <sub>DD</sub>	DC Power Supply	2.5	-	5.5	V	-
V <sub>LDO</sub>	Output Voltage	1.62	1.8	1.98	V	-
T <sub>A</sub>	Temperature	-40	25	105	°C	

**Notes:**

1. It is recommended a 0.1µF bypass capacitor is connected between V<sub>DD</sub> and the closest V<sub>SS</sub> pin of the device.

### 8.4.3 Brown-out Detector

Symbol	Parameter	Min	Typ	Max	Unit	Test Condition
AV <sub>DD</sub>	Supply Voltage	0	-	5.5	V	-
T <sub>A</sub>	Temperature	-40	25	105	°C	-

I <sub>BOD</sub>	Quiescent Current	-	100	-	μA	AV <sub>DD</sub> =5.5V
V <sub>BOD</sub>	Brown-out Detector (Falling edge)		4.3		V	BOV_VL [2:0] = 3
			3.7		V	BOV_VL [2:0] = 2
			3.0		V	BOV_VL [2:0] = 7
			2.7		V	BOV_VL [2:0] = 1
			2.4		V	BOV_VL [2:0] = 6
			2.2		V	BOV_VL [2:0] = 0
			2.0		V	BOV_VL [2:0] = 5
			1.7		V	BOV_VL [2:0] = 4

#### 8.4.4 Power-on Reset

Symbol	Parameter	Min	Typ	Max	Unit	Test Condition
T <sub>A</sub>	Temperature	-40	25	105	°C	-
V <sub>POR</sub>	Reset Voltage		1.25		V	-

#### 8.4.5 Comparator

Symbol	Parameter	Min	Typ	Max	Unit	Test Condition
V <sub>CMP</sub>	Supply Voltage	2.5	-	5.5	V	
T <sub>A</sub>	Temperature	-40	25	105	°C	-
I <sub>CMP</sub>	Operation Current	-	40	80	μA	AV <sub>DD</sub> =5V
V <sub>OFF</sub>	Input Offset Voltage		10	20	mV	-
V <sub>SW</sub>	Output Swing	0.1	-	AV <sub>DD</sub> - 0.1	V	-
V <sub>COM</sub>	Input Common Mode Range	0.1	-	AV <sub>DD</sub> - 0.1	V	-
-	DC Gain	-	60	-	dB	-
T <sub>PGD</sub>	Propagation Delay	-	200	-	ns	V <sub>COM</sub> =1.2 V, V <sub>DIFF</sub> =0.1 V
V <sub>HYS</sub>	Hysteresis	-	±30	-	mV	V <sub>COM</sub> =1.2 V
T <sub>STB</sub>	Stable time	-	-	1.2	μs	



### 8.5 Flash DC Electrical Characteristics

Symbol	Parameter	Min	Typ	Max	Unit	Test Condition
V <sub>FLA</sub> <sup>[2]</sup>	Supply Voltage	1.62	1.8	1.98	V	
N <sub>ENDUR</sub>	Endurance	20,000	-	-	cycles <sup>[1]</sup>	
T <sub>RET</sub>	Data Retention	10	-	-	year	T <sub>A</sub> =85°C
T <sub>ERASE</sub>	Sector Erase Time	-	6	-	ms	
T <sub>PROG</sub>	Program Time	-	7.5	-	us	
I <sub>DD1</sub>	Read Current	-	4	-	mA	
I <sub>DD2</sub>	Program Current	-	3.5	-	mA	
I <sub>DD3</sub>	Erase Current	-	2	-	mA	

**Notes:**

1. Number of program/erase cycles.
2. V<sub>FLA</sub> is source from chip LDO output voltage.
3. Guaranteed by design, not test in production.

9 PACKAGE DIMENSIONS

9.1 48-pin LQFP

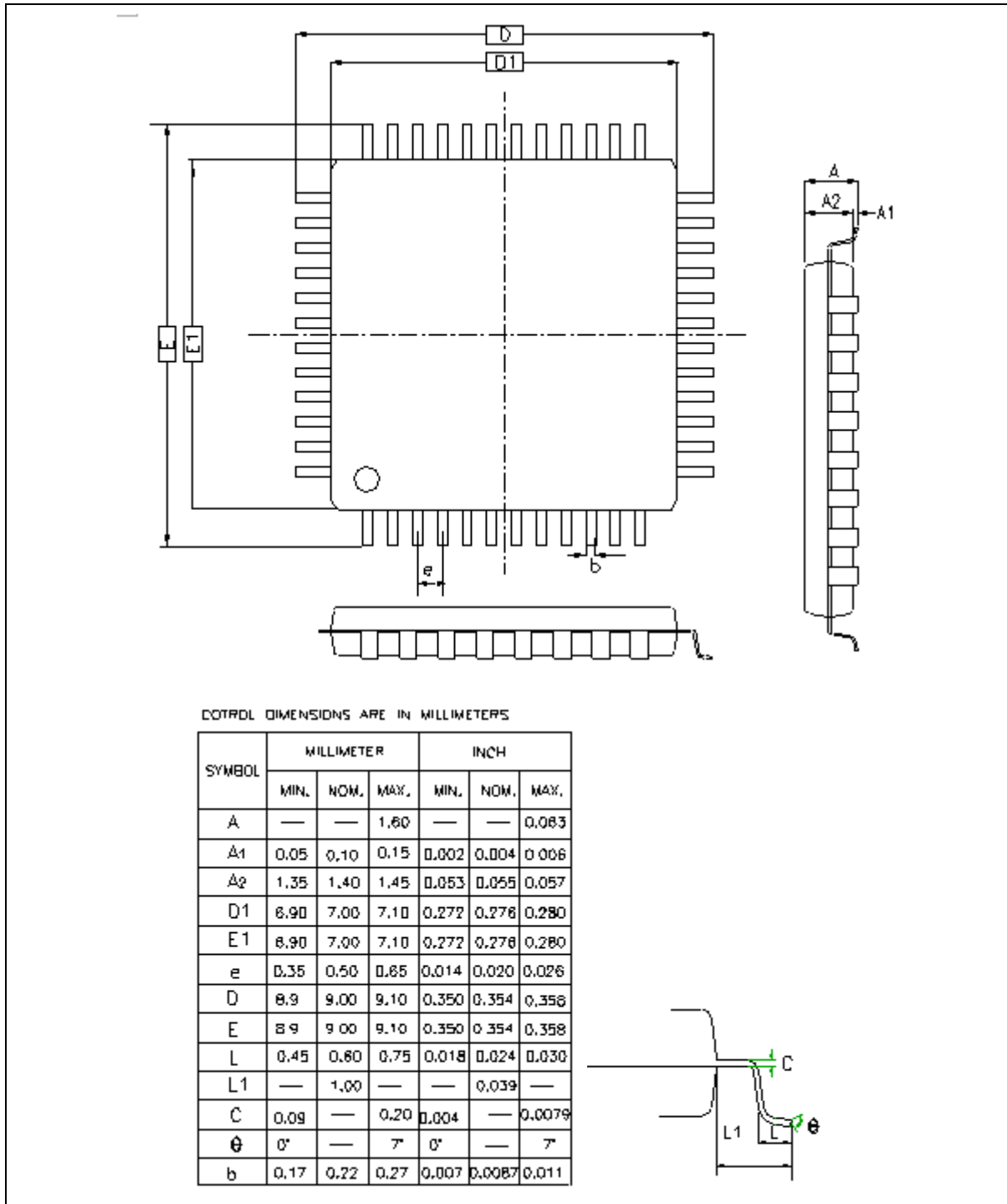

9.2 33-pin QFN (5 mm x 5 mm)

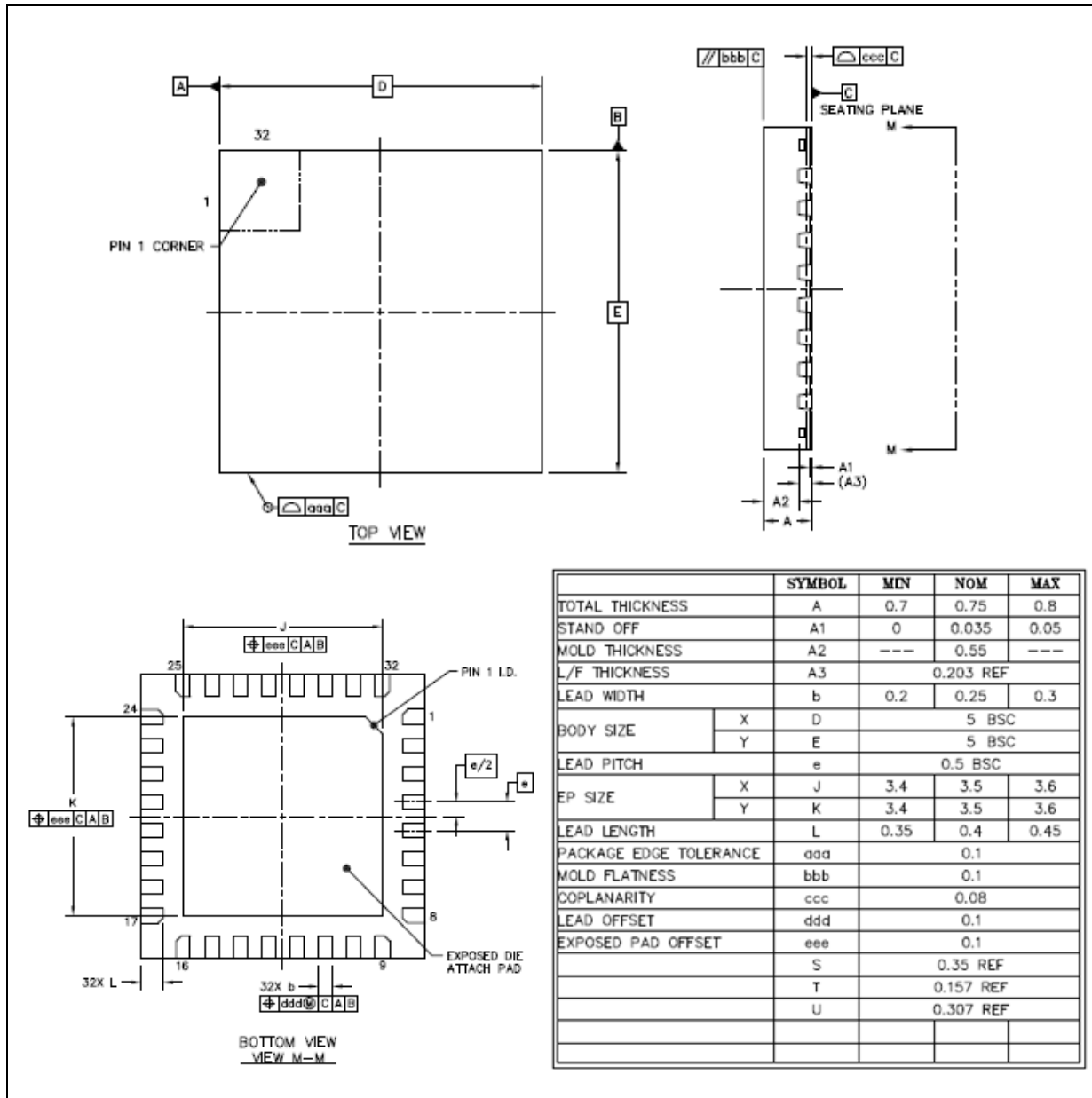

9.3 20-pin TSSOP

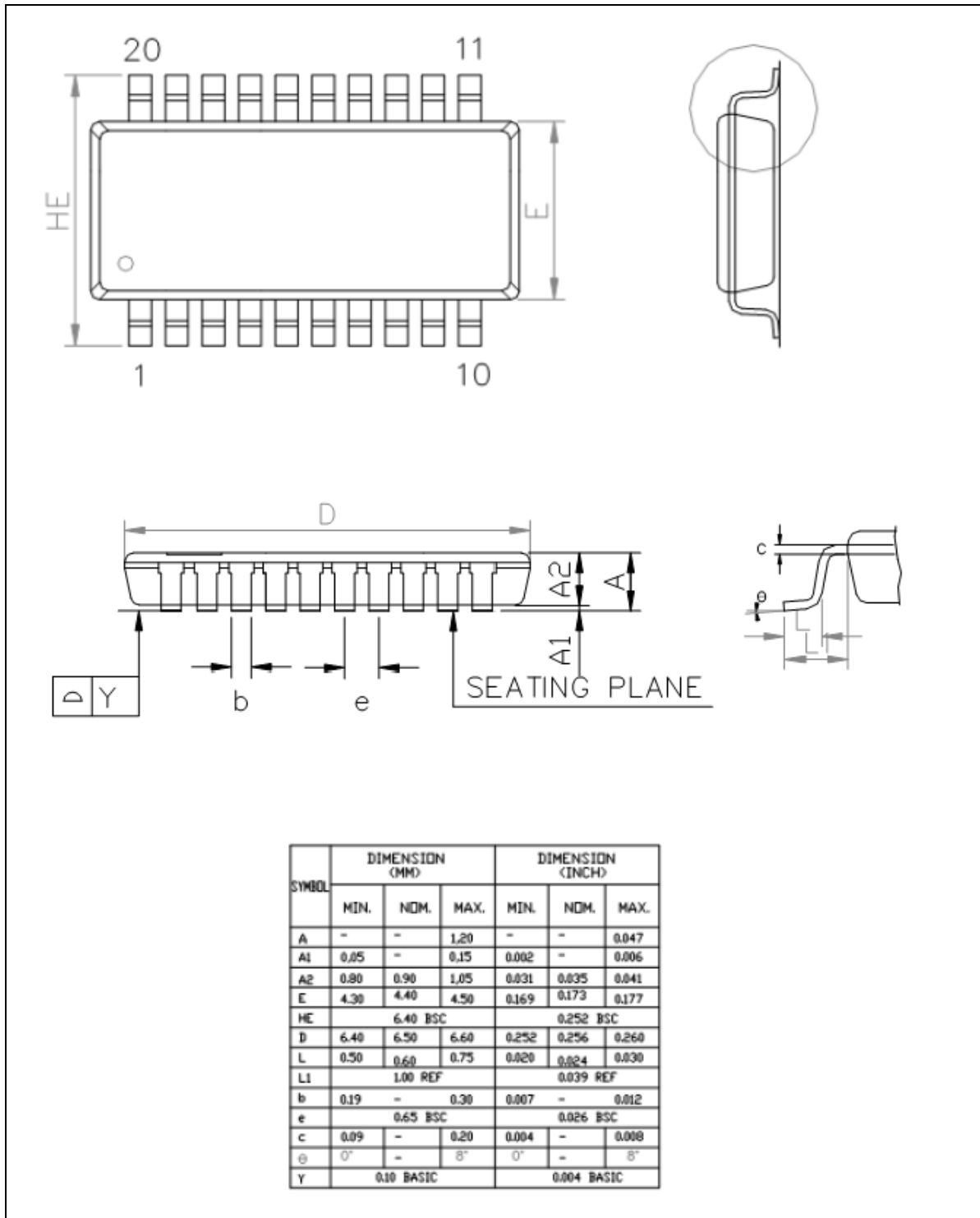

**10 REVISION HISTORY**

Date	Revision	Description
2015.07.14	1.00	Preliminary version.
2015.08.10	1.01	1. add Z:QFN 33 5x5mm of package type of Figure 4.1-1. 2. modify HIRC to 48Mhz from 22.1184MHz of Table 4.2-1.
2015.11.05	1.02	1. modify DC Electrical Characteristics part, add I <sub>DD</sub> and I <sub>IDLE</sub> of HIRC (48MHz/44.2368MHz/24MHz)
2016.08.01	1.03	1. Modify 9.3 20-pin QFN (4 mm x 4 mm) package dimension 2. Add QFN 33 5x5mm selection guide of Table 4.2-1. 3. Add QFN 33 5x5mm package dimension
2017.12.08	1.08	1. Update the content of ELECTRICAL CHARACTERISTICS.
2018.05.23	1.09	1.Remove the extra information of parts in QFN33(4x4) and QFN20.
2018.11.09	1.10	1. In section 4.4 Pin Description, add a note for pins ICE_CLK and ICE_DAT that the 2 pins should not be in floating state when MCU is in operation.
2019.01.30	1.10	1. Add "(EPWM)" in the title of 6.7 Enhanced PWM Generator (EPWM)
2022.11.08	1.12	1. Add compliance statement of International Environmental Regulations.

### Important Notice

Nuvoton Products are neither intended nor warranted for usage in systems or equipment, any malfunction or failure of which may cause loss of human life, bodily injury or severe property damage. Such applications are deemed, "Insecure Usage".

Insecure usage includes, but is not limited to: equipment for surgical implementation, atomic energy control instruments, airplane or spaceship instruments, the control or operation of dynamic, brake or safety systems designed for vehicular use, traffic signal instruments, all types of safety devices, and other applications intended to support or sustain life.

All Insecure Usage shall be made at customer's risk, and in the event that third parties lay claims to Nuvoton as a result of customer's Insecure Usage, customer shall indemnify the damages and liabilities thus incurred by Nuvoton.

---

*Please note that all data and specifications are subject to change without notice.  
All the trademarks of products and companies mentioned in this datasheet belong to their respective owners.*