



Messrs.					
Product Specification	Model:	MTB-F000368MNHNA	Rev. No.	Issued Date.	Page.
			A	Sep.29, 05	1 / 22

LIQUID CRYSTAL DISPLAY MODULE
MODEL: MTB-F000368MNHNA
Customer's No.:

Acceptance

Microtips Technology Inc.
 12F. No.31 Lane 169, Kang Ning St., His-Chih,
 Taipei Hsien, Taiwan, R.O.C.
 FAX: 886-2-26958625

Approved and Checked by

Approved by	Checked by		Made by
			



Microtips Technology Inc.

Messrs.					
Product Specification	Model:	MTB-F000368MNHNAA	Rev. No.	Issued Date.	Page.
			A	Sep.29, 05	2 / 22

Revise Records

Rev.	Date	Contents	Written	Approved
A	2005/7/23	Preliminary Spec	David Ma	Garry Chen
A	2005/9/5	See Note1	David Ma	Garry Chen
A	2005/9/29	See Note2	David Ma	Garry Chen

Special Notes

Note1.	With DC/DC circuit built in, revised in 4.2 and 4.3 (page12,13)
Note2.	Add schematics (page 13)
Note3.	
Note4.	
Note5.	



Messrs.					
Product Specification	Model:	MTB-F000368MNHNA	Rev. No.	Issued Date.	Page.
			A	Sep.29, 05	3 / 22

Contents

1.	General Specifications	4
2.	Electrical Specifications	5
2.1	Absolute Maximum Ratings.....	5
2.2	DC Characteristics.....	5
2.3	AC Characteristics	6
2.4	Power Supply ON/OFF Sequence.....	8
2.5	Lighting Specifications.....	9
3.	Optical Specifications	10
3.1	LCD Driving Voltage Recommended.....	10
3.2	Optical Characteristics	10
3.3	Definition of Viewing Angle and Optimum Viewing Area	11
3.5	Definition of Contrast C.....	11
4.	I/O Terminal.....	12
4.1	Pin Assignment	12
4.2	Example of Power Supply	12
4.3	Block Diagram	13
5.	Schematics	13
6.	Reliability Test.....	15
6.1	Test Item.....	15
6.2	Judgment Standard.....	16
7.	Appearance Standards	17
7.1	Inspection Conditions	17
7.2	Definition of Applicable Zones	17
7.3	Standards.....	18
8.	Handling and Precautions.....	20
9.	Warranty:.....	21
10.	Dimensional Outlines.....	21



Messrs.					
Product Specification	Model:	MTB-F000368MNHNA	Rev. No.	Issued Date.	Page.
			A	Sep.29, 05	4 / 22

1. General Specifications

Operating Temperature	:	Min. -20°C ~ Max. 70°C
Storage Temperature	:	Min. -30°C ~ Max. 80°C
Dot Pixels	:	122 (W) x 32 (H) dots
Dot Size	:	0.42 (W) x 0.47 (H) mm
Dot Pitch	:	0.44 (W) x 0.49 (H) mm
Viewing Area	:	60.5 (W) x18.5 (H) mm
Outline Dimensions	:	80.0 (W) x 36.0 (H) x 14.0max. (D) mm
Weight	:	N/A
LCD Type	:	FSTN/ Negative mode/ Transmissive
Viewing Direction	:	12:00
Backlight	:	Array LED B/L (Amber)
LCD LSI	:	SBN1661G_M02
Drawings	:	As attached drawings



Messrs.					
Product Specification	Model:	MTB-F000368MNHNA	Rev. No.	Issued Date.	Page.
			A	Sep.29, 05	5 / 22

2. Electrical Specifications

2.1 Absolute Maximum Ratings

$V_{SS} = 0V$

Parameter	Symbol	Conditions	Min.	Max.	Units
Supply Voltage (Logic)	$V_{DD} - V_{SS}$	-	- 0.3	8.0	V
Supply Voltage (LCD Drive)	$V_{DD} - V_{EE}$	-	-0.30	16.5	V
Input Voltage	V_I	-	- 0.3	$V_{DD} + 0.3$	V

2.2 DC Characteristics

$T_a = 25^\circ C, V_{SS} = 0V$

Parameter	Symbol	Conditions	Min.	Typ.	Max.	Units
Supply Voltage (Logic)	$V_{DD} - V_{SS}$	-	4.5	5.0	5.5	V
Supply Voltage (LCD Drive)	$V_{DD} - V_O$	Shown in 3.1				V
High Level Input Voltage	V_{IHT}	Note 1	2.0	-	V_{DD}	V
	V_{IHC}		$0.8V_{DD}$	-	V_{DD}	V
Low Level Input Voltage	V_{ILT}	Note 1	0	-	0.8	V
	V_{ILC}		0	-	$0.2V_{DD}$	V
High Level Output Voltage	V_{OH}	$I_{OH} = -3.0mA$ Note 2	2.4	-	-	V
Low Level Output Voltage	V_{OL}	$I_{OH} = 3.0mA$ Note 2	-	-	0.4	V
Supply Current	I_{DD}	$V_{DD} - V_{SS}$	-	0.6	1.1	mA
	I_{EE}	$V_{DD} - V_{EE}$	-	1.8	3.3	mA

Note 1 : Applied to A0, CS1, CS2, DB0~DB7, E(RD), R/W(WR).

Note 2 : Applied to DB0~DB7.



Microtips Technology Inc.

Messrs.					
Product Specification	Model:	MTB-F000368MNHNA	Rev. No.	Issued Date.	Page.
			A	Sep.29, 05	6 / 22

2.3 AC Characteristics

2.3.1 MPU Bus Read/Write I (80-family MPU)

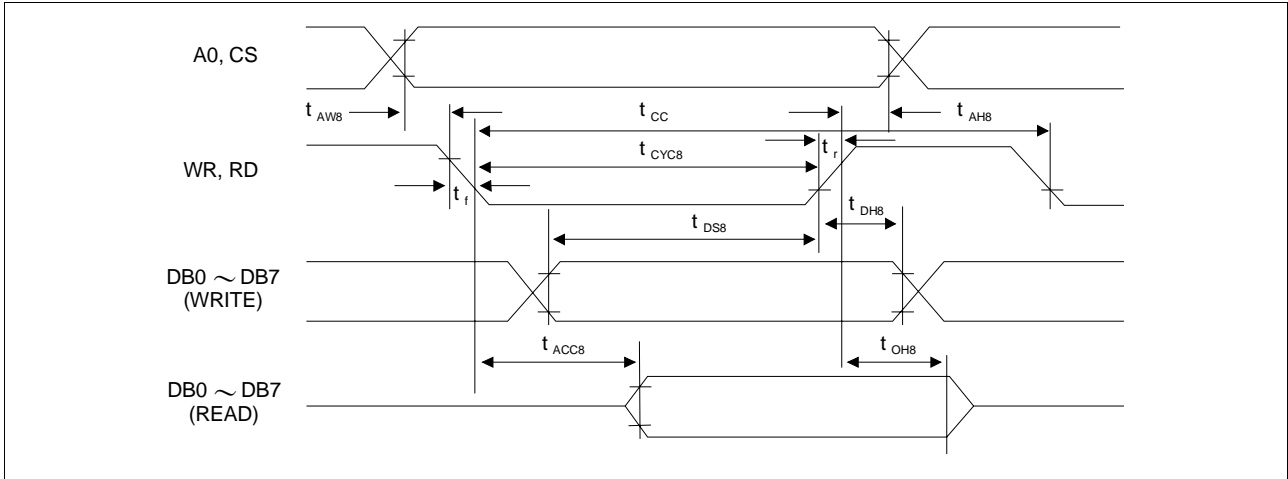

Ta = -20~70°C, V_{DD} = 5.0V ± 10%, unless state otherwise

Parameter	Symbol	Condition	Rating		Unit	Signal
			Min.	Max.		
Address hold time	t _{AH8}	-	10	-	ns	A0, CS
Address setup time	t _{AW8}	-	20	-	ns	
System cycle time	t _{CYC8}	-	1000	-	ns	WR, RD
Control pulse-width	t _{CC}	-	200	-	ns	
Data setup time	t _{DS8}	-	80	-	ns	D0 to D7
Data hold time	t _{DH8}	-	10	-	ns	
RD access time	t _{ACC8}	C _L = 100pF	-	90	ns	
Output disable time	t _{CH8}		10	60	ns	
Rise and fall time	t _r , t _f	-	-	15	ns	

Ta = -20~70°C, V_{DD} = 3.0V ± 10%, unless state otherwise

Parameter	Symbol	Condition	Rating		Unit	Signal
			Min.	Max.		
Address hold time	t _{AH8}	-	20	-	ns	A0, CS
Address setup time	t _{AW8}	-	40	-	ns	
System cycle time	t _{CYC8}	-	2000	-	ns	WR, RD
Control pulse-width	t _{CC}	-	400	-	ns	
Data setup time	t _{DS8}	-	160	-	ns	D0 to D7
Data hold time	t _{DH8}	-	20	-	ns	
RD access time	t _{ACC8}	C _L = 100pF	-	180	ns	
Output disable time	t _{CH8}		20	120	ns	
Rise and fall time	t _r , t _f	-	-	15	ns	



Microtips Technology Inc.

2.3.2 MPU Bus Read/Write II (68-family MPU)

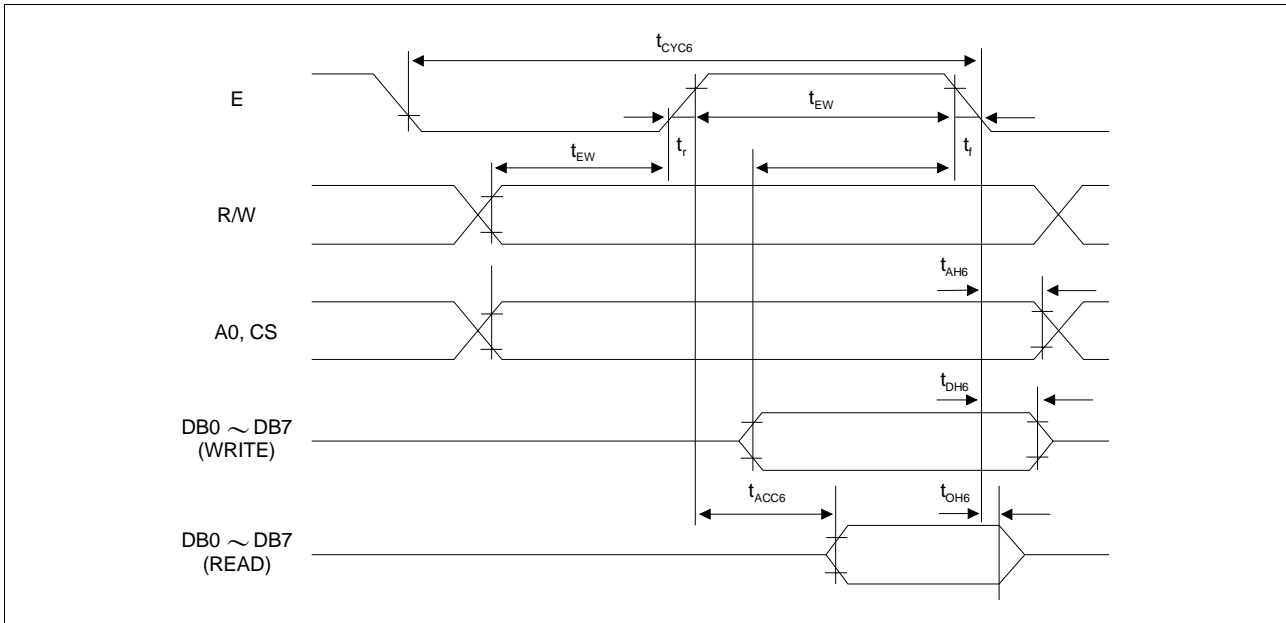

Ta = -20~70°C, V_{DD} = 5.0V ± 10%, unless state otherwise

Parameter	Symbol	Condition	Rating		Unit	Signal
			Min.	Max.		
System cycle time	t _{CYC6}		1000	-	ns	
Address setup time	t _{AW6}		20	-	ns	A0, CS, R/W
Address hold time	t _{AH6}		10	-	ns	
Data setup time	t _{DS6}		80	-	ns	D0 to D7
Data hold time	t _{DH6}		10	-	ns	
Output disable time	t _{OH6}	C _L = 100pF	10	60	ns	
Access time	t _{ACC6}		-	90	ns	
Enable pulse-width	Read	t _{EW}	100	-	ns	E
	Write		80	-	ns	
Rise and fall time	t _r , t _f	-	-	15	Ns	-

Ta = -20~70°C, V_{DD} = 3.0V ± 10%, unless state otherwise

Parameter	Symbol	Condition	Rating		Unit	Signal
			Min.	Max.		
System cycle time	t _{CYC6}		2000	-	ns	
Address setup time	t _{AW6}		40	-	ns	A0, CS, R/W
Address hold time	t _{AH6}		20	-	ns	
Data setup time	t _{DS6}		160	-	ns	D0 to D7
Data hold time	t _{DH6}		20	-	ns	
Output disable time	t _{OH6}	C _L = 100pF	20	120	ns	
Access time	t _{ACC6}		-	180	ns	
Enable pulse-width	Read	t _{EW}	200	-	ns	E
	Write		160	-	ns	
Rise and fall time	t _r , t _f	-	-	15	ns	-



Messrs.					
Product Specification	Model:	MTB-F000368MNHNA	Rev. No.	Issued Date.	Page.
			A	Sep.29, 05	8 / 22

2.4 Power Supply ON/OFF Sequence

2.4.1 ON Sequence

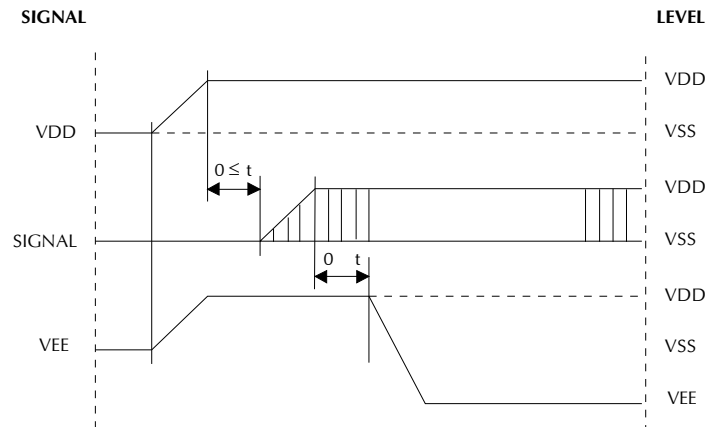

2.4.2 OFF Sequence

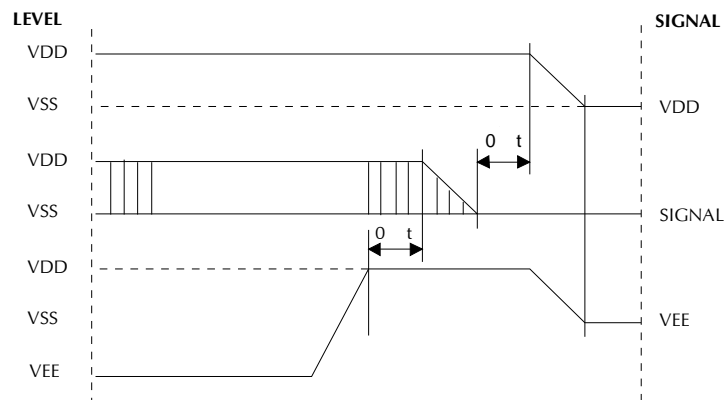

Please maintain the above sequence when turning on and off the power supply of the module. If VEE is supplied to the module while internal alternate signal for LCD driving (M) is unstable or RESET is active, DC component will be supplied to the LCD panel. This may cause damage to the LCD module.



Microtips Technology Inc.

Messrs.					
Product Specification	Model:	MTB-F000368MNHNA	Rev. No.	Issued Date.	Page.
			A	Sep.29, 05	9 / 22

2.5 Lighting Specifications

2.5.1 Absolute Maximum Ratings

Ta = 25°C

Parameter	Symbol	Conditions	Min.	Typ.	Max.	Units
Forward Current	I _F	-	-	-	195	mA
Reverse Voltage	V _R	-	-	-	5.0	V
LED Power Dissipation	P _D	-	-	-	905	mW

2.5.2 Operating Characteristics

Ta = 25°C

Parameter	Symbol	Conditions	Min.	Typ.	Max.	Units
Forward Voltage	V _F	I _F = 130mA	3.6	3.8	4.6	V
Luminance of Backlight Surface*	L		700	1000	-	cd/m ²
Spectrum radiation bandwidth	Δλ		-	30	-	nm
Peak emission wavelength	λ _p		603	606	609	nm

*Measured from the surface of backlight.

2.5.3 Schematics Related

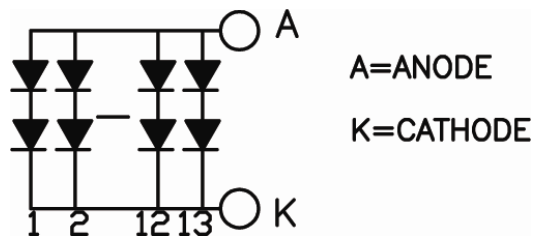

Microtips Technology Inc.

Messrs.					
Product Specification	Model:	MTB-F000368MNHNA	Rev. No.	Issued Date.	Page.
			A	Sep.29, 05	10 / 22

3. Optical Specifications

3.1 LCD Driving Voltage Recommended

Parameter	Symbol	Conditions	Min.	Typ.	Max.	Units
LCD Driving Voltage Note 1	$V_{DD}-V_O$	Ta = -20 °C	-	TBD	-	V
		Ta = 25 °C	TBD	(6.05)	TBD	V
		Ta = 70 °C	-	TBD	-	V

Note 1 : Voltage (Applied actual waveform to LCD Module, bias = 1/4.2) for the best contrast. The range of minimum and maximum shows tolerance of the operating voltage. The specified contrast ratio and response time are not guaranteed over the entire range.

3.2 Optical Characteristics

Ta=25 °C, 1/32 Duty, 1/5 Bias, $V_{DD} = 5V$ (Note 4), $\theta = 0^\circ$, $\phi = -^\circ$

Parameter	Symbol	Conditions	Min.	Typ.	Max.	Units
Contrast Ratio Note 1	C	$\theta = 0^\circ, \phi = 0^\circ$	-	(6.0)	-	-
Viewing Angle (Shown in 3.3)	Front-Back	$\theta_l - \theta_b, \phi = 0^\circ$	+30	to	-10	deg.
	Left-Right	$\theta_l - \theta_r, \phi = 0^\circ$	+30	to	-30	deg.
Response Time	Rise Note 2	T_{ON}	-	(160)	TBD	msec
	Decay Note 3	T_{OFF}	-	(130)	TBD	msec

Note 1 : Contrast ratio is defined as follows.

$$CR = L_{OFF} / L_{ON}$$

L_{ON} : Luminance of the ON segments, L_{OFF} : Luminance of the OFF segments

Note 2 : The time that the luminance level reaches 90% of the saturation level from 0% when ON signal is applied.

Note 3 : The time that the luminance level reaches 10% of the saturation level from 100% when OFF signal is applied.

Note 4 : Definition of Driving Voltage V_D . Assuming that the typical driving waveforms shown below are applied to the LCD Panel at 1/A Duty - 1/B Bias (A : Duty Number, B : Bias Number). Driving voltage V_D is defined as follows: $V_D = (V_{th1} + V_{th2}) / 2$

V_{th1} : The voltage VO-P that should provide 50% of the saturation level in the luminance at the segment which the ON signal is applied to.

V_{th2} : The voltage VO-P that should provide 50% of the saturation level in the luminance at the segment which the OFF signal is applied to.

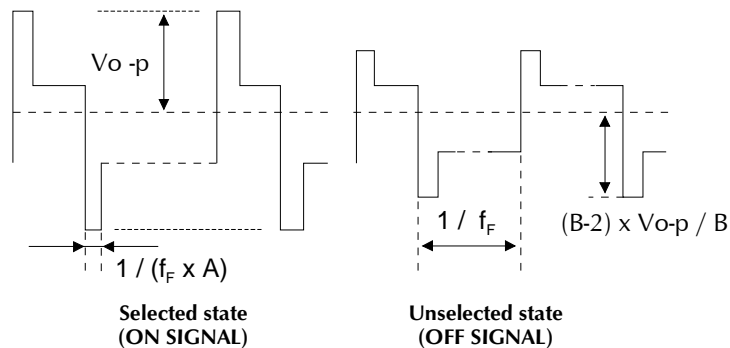

Messrs.					
Product Specification	Model:	MTB-F000368MNHNA	Rev. No.	Issued Date.	Page.
			A	Sep.29, 05	11 / 22

3.3 Definition of Viewing Angle and Optimum Viewing Area

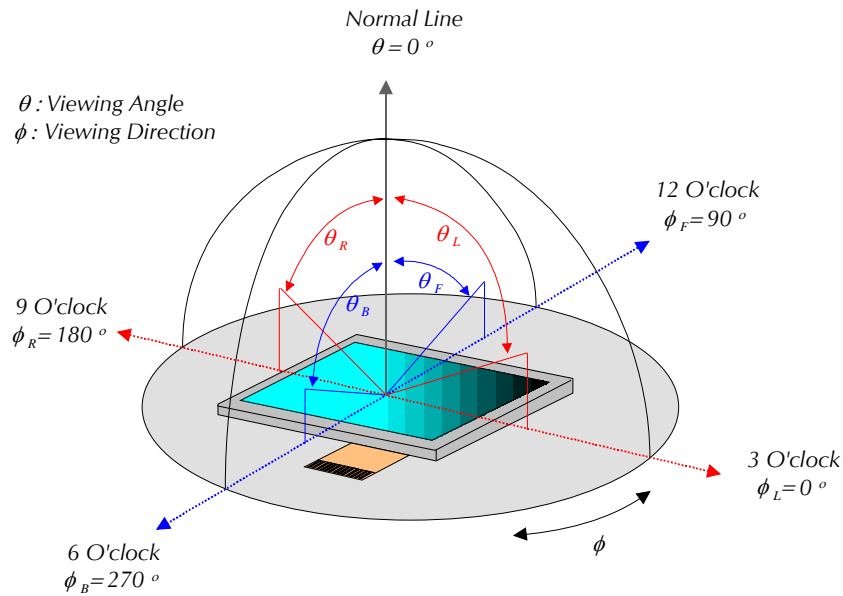

3.4 Definition of Viewing Angle θ_f and θ_b

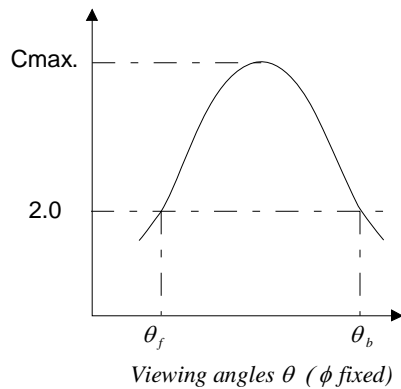

Optimum viewing angle with the naked eye and viewing angle θ at Cmax. Above are not always the same.

3.5 Definition of Contrast C

$C = \text{Brightness of selected dot (B1)} / \text{Brightness of unselected dot (B2)}$

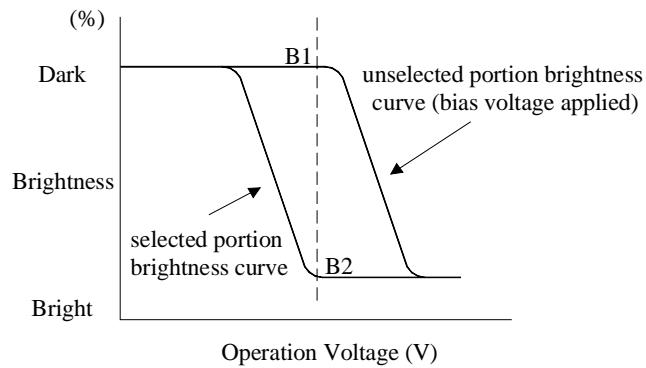

Microtips Technology Inc.

Messrs.					
Product Specification	Model:	MTB-F000368MNHNA	Rev. No.	Issued Date.	Page.
			A	Sep.29, 05	12 / 22

4. I/O Terminal

4.1 Pin Assignment

No.	Symbol	Level	Function
1	V _{SS}	--	GND
2	V _{DD} (Vcc)	--	Logic supply voltage
3	Vo(V _{EE} /V _{lcd})	--	LCD driver supply voltage
4	A0	H / L	Display Data/Display commands switching input. A0=0: DB0~DB7 are command input and status output. A0=1: DB0~DB7 are Display Data input/output.
5	CS1	H / L	Chip select pin for the left half of the screen. Active LOW
6	CS2	H / L	Chip select pin for the right half of the screen. Active LOW
7	CL	--	External clock input (typical : 2kHz)
8	/RD (E)	H / L	/RD for 8080 series, E for 6800 series.
9	/WR (R/W)	H / L	/WR for 8080 series, R/W for 6800 series.
10	DB0	I/O	3-state I/O Data Bus.
11	DB1	I/O	
12	DB2	I/O	
13	DB3	I/O	
14	DB4	I/O	
15	DB5	I/O	
16	DB6	I/O	
17	DB7	I/O	
18	RES	H/L	Reset. High for 8080 series, Low for 6800 series.
19	LEDA(BKL1)	--	Power supply for LED B/L anode.
20	LEDK(BKL2)	--	Power supply for LED B/L cathode.

4.2 Example of Power Supply

It is recommended to apply a potentiometer for the contrast adjust due to the tolerance of the driving voltage and its temperature dependence.

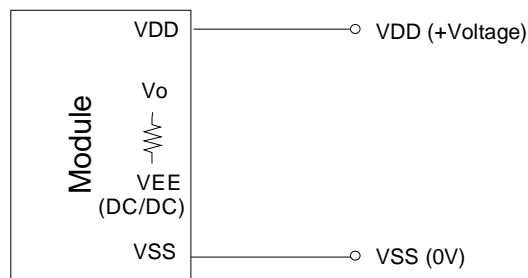

Messrs.					
Product Specification	Model:	MTB-F000368MNHNA	Rev. No.	Issued Date.	Page.
			A	Sep.29, 05	13 / 22

4.3 Block Diagram

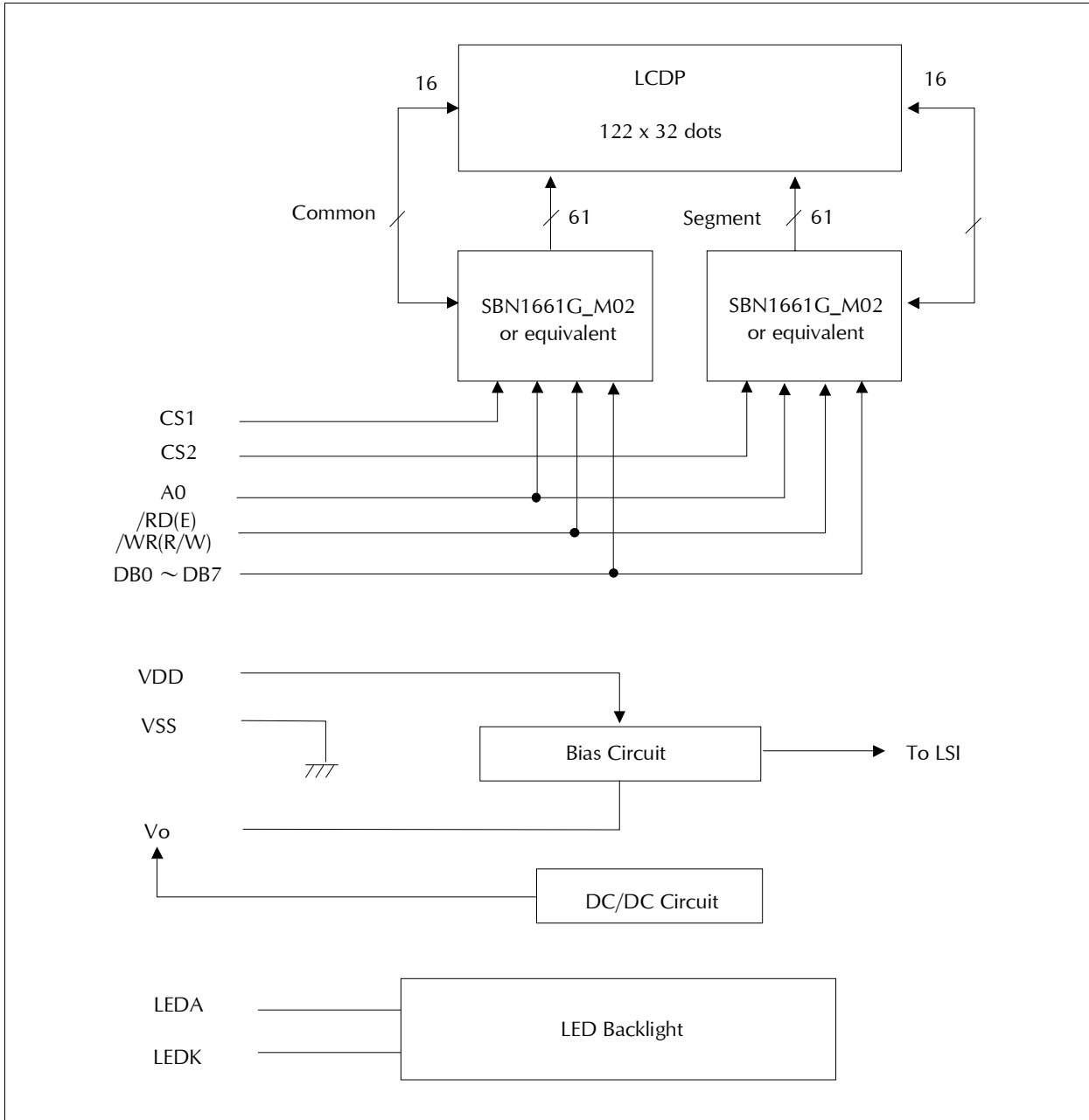

5. Schematics



Microtips Technology Inc.

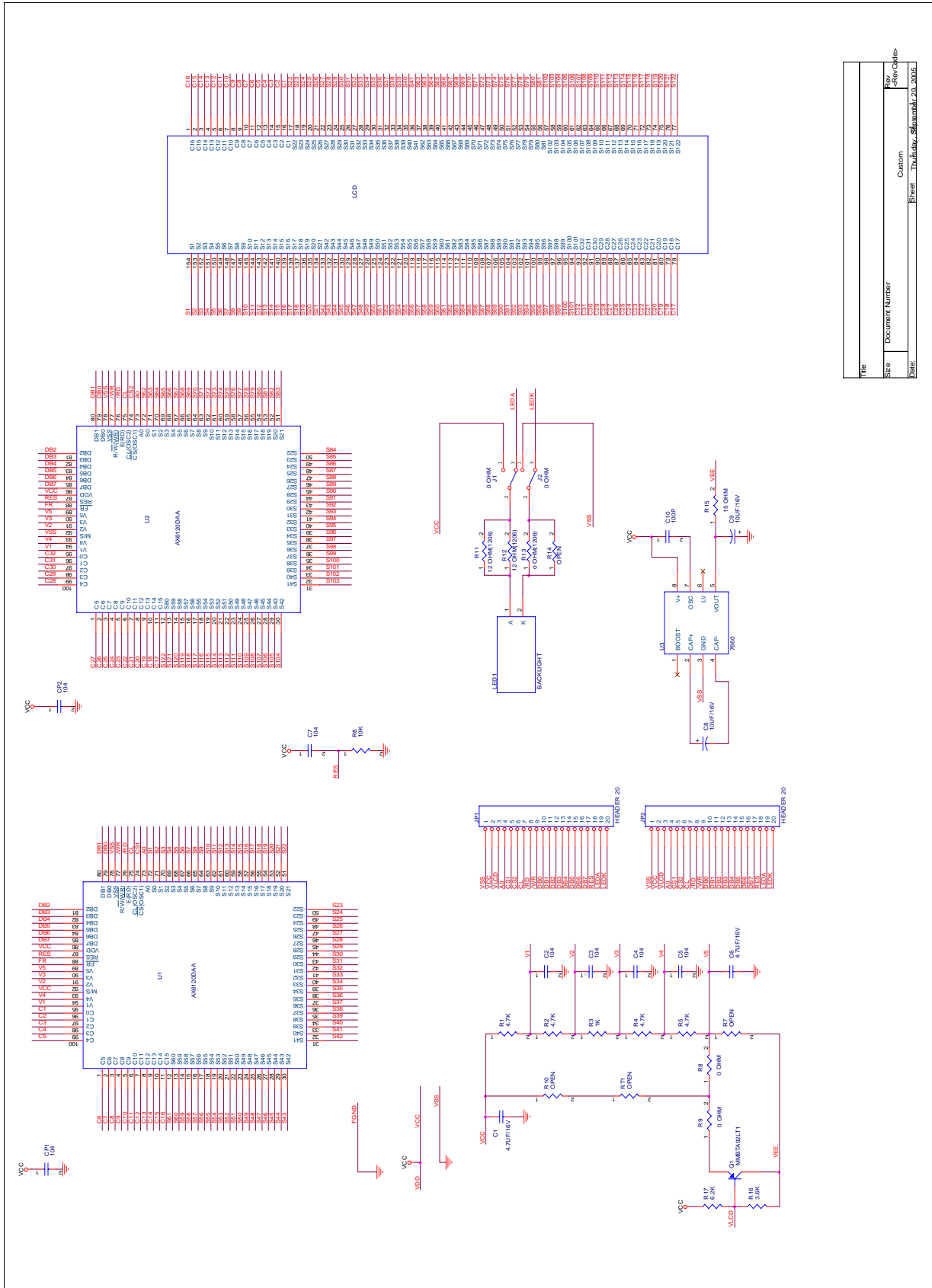

File	
Doc Number	Custom
Rev	Rev 01
Date	Rev 01 - 29/09/2005



Messrs.					
Product Specification	Model:	MTB-F000368MNHNA	Rev. No.	Issued Date.	Page.
			A	Sep.29, 05	15 / 22

6. Reliability Test

6.1 Test Item

No change on display and in operation under the following test condition.

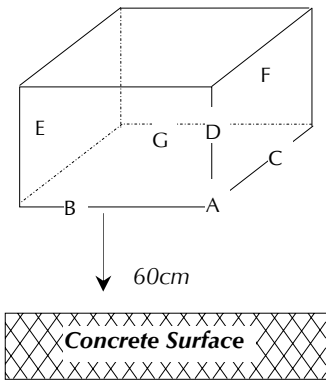
No.	Test Item	Description	Condition	Note
1.	High Temperature (Operation)	Durability test under long time high temperature with electrical stress (voltage, current)	70°C ± 2°C 96hrs	
2.	High Temperature (Storage)	Durability test under long time high temperature storage	80°C ± 2°C 96hrs	4
3.	Low Temperature (Operation)	Durability test under long time low temperature with electrical stress (voltage, current)	-20°C ± 2°C, 96hrs	3
4.	Low Temperature (Storage)	Durability test under long time low temperature storage	-30°C ± 2°C, 96hrs	3, 4
5.	Damp Proof Test	Durability test under long time high temperature and high humidity	40°C ± 2°C, 90~95% RH 96hrs	3, 4
6.	Vibration Test	Total fixed amplitude: 1.5mm Vibration frequency: 10~55Hz One cycle 60 seconds to 3 directions of X, Y, Z for each 15 minutes	--	5
7.	Drop Test	To be measured after dropping from 60cm high on the concrete surface in packing state.  <i>Dropping method corner dropping</i> A corner: once <i>Edge dropping</i> B, C, D edge: once <i>Face dropping</i> E, F, G face: once		

Note 1: Unless otherwise specified, tests will be conducted under the following condition,

Temperature : 25°C ± 2°C

Humidity : 65% ± 5%

Note 2: Unless otherwise specified, tests will be not conducted under functioning state.

Note 3: No dew condensation to be observed.

Note 4: The function test shall be conducted after 4 hours storage at the normal temperature and humidity after removed from the test chamber.

Note 5: Vibration test will be conducted to the product itself without putting it in a container.



Microtips Technology Inc.

Messrs.					
Product Specification	Model:	MTB-F000368MNHNA	Rev. No.	Issued Date.	Page.
			A	Sep.29, 05	16 / 22

6.2 Judgment Standard

Failure Mode	Test Item							Judgment Standard
	1	2	3	4	5	6	7	
Orientation	*	*	*	*	*			No remarkable degradation of appearance under bias/ non-bias condition
Current Value (IAC)	*	*	*	*	*			No remarkable increase
Contrast	*		*	*	*			No remarkable poor contrast
Domain	*	*	*	*	*			Less than 20% of all dots have reverse tilt of more than on third of one dot area.
Bubble (Inside Cell)	*	*	*	*	*	*		As per "Appearance Standard" (Note. Including one which disappear after 25°C 2H)
Polarizer	*				*	*		As per "Appearance Standard" no remarkable appearance change
Glass Damage							*	As per "Appearance Standard"

Note.1. * is strong linkage between Failure Mode and Test Item.

2. Number of Test Item should be referred to former page.

3. Judgment and Standard value should be fixed by other inspection standard and criteria samples.



Microtips Technology Inc.

Messrs.					
Product Specification	Model:	MTB-F000368MNHNA	Rev. No.	Issued Date.	Page.
			A	Sep.29, 05	17 / 22

7. Appearance Standards

7.1 Inspection Conditions

The LCD shall be inspected under 40W white fluorescent light. The distance between the eyes and the sample shall be more than 30cm. All directions for inspecting the sample should be within 45° against perpendicular line.

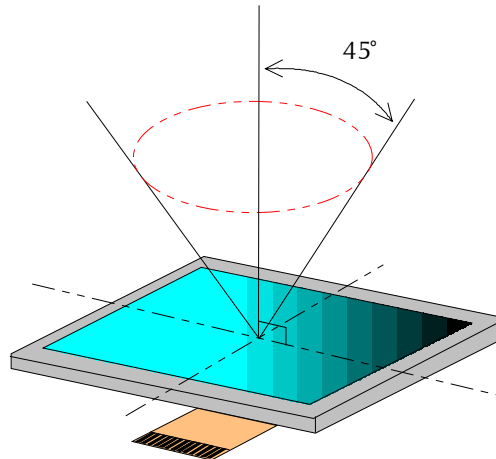

7.2 Definition of Applicable Zones

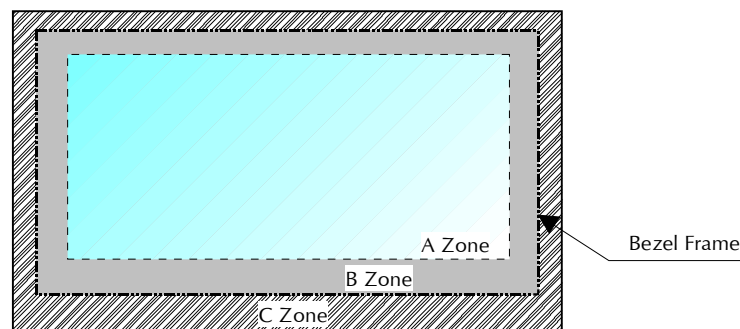

A Zone : Active display area

B Zone : Area from outside of "A Zone" to validity viewing area

C Zone : Rest parts

A Zone + B Zone = Validity viewing area



Microtips Technology Inc.

Messrs.					
Product Specification	Model:	MTB-F000368MNHNA	Rev. No.	Issued Date.	Page.
			A	Sep.29, 05	18 / 22

7.3 Standards

No.	Parameter	Criteria																																																									
1.	Black and White Spots, Foreign Substances	<p>(1) Round Shape</p> <table border="1"> <thead> <tr> <th rowspan="2">Dimension (mm) \ Zone</th> <th colspan="3">Acceptable Number</th> </tr> <tr> <th>A</th> <th>B</th> <th>C</th> </tr> </thead> <tbody> <tr> <td>D ≤ 0.1</td> <td>*</td> <td>*</td> <td>*</td> </tr> <tr> <td>0.1 < D ≤ 0.2</td> <td>3</td> <td>5</td> <td>*</td> </tr> <tr> <td>0.2 < D ≤ 0.25</td> <td>2</td> <td>3</td> <td>*</td> </tr> <tr> <td>0.25 < D ≤ 0.3</td> <td>0</td> <td>1</td> <td>*</td> </tr> <tr> <td>0.3 < D</td> <td>0</td> <td>0</td> <td>*</td> </tr> </tbody> </table> <p>D = (Long + Short)/2 *: Disregard</p> <p>(2) Line Shape</p> <table border="1"> <thead> <tr> <th>Zone \ X (mm)</th> <th>Zone \ Y (mm)</th> <th colspan="3">Acceptable Number</th> </tr> <tr> <th></th> <th></th> <th>A</th> <th>B</th> <th>C</th> </tr> </thead> <tbody> <tr> <td>--</td> <td>0.03 ≥ W</td> <td>*</td> <td>*</td> <td>*</td> </tr> <tr> <td>2.0 ≥ L</td> <td>0.05 ≥ W</td> <td>3</td> <td>3</td> <td>*</td> </tr> <tr> <td>1.0 ≥ L</td> <td>0.1 ≥ W</td> <td>3</td> <td>3</td> <td>*</td> </tr> <tr> <td>--</td> <td>0.1 < W</td> <td colspan="3">In the same way (1)</td> </tr> </tbody> </table> <p>X : Length Y: Width *: Disregard</p> <p>Total defects shall not exceed 5.</p>	Dimension (mm) \ Zone	Acceptable Number			A	B	C	D ≤ 0.1	*	*	*	0.1 < D ≤ 0.2	3	5	*	0.2 < D ≤ 0.25	2	3	*	0.25 < D ≤ 0.3	0	1	*	0.3 < D	0	0	*	Zone \ X (mm)	Zone \ Y (mm)	Acceptable Number					A	B	C	--	0.03 ≥ W	*	*	*	2.0 ≥ L	0.05 ≥ W	3	3	*	1.0 ≥ L	0.1 ≥ W	3	3	*	--	0.1 < W	In the same way (1)		
Dimension (mm) \ Zone	Acceptable Number																																																										
	A	B	C																																																								
D ≤ 0.1	*	*	*																																																								
0.1 < D ≤ 0.2	3	5	*																																																								
0.2 < D ≤ 0.25	2	3	*																																																								
0.25 < D ≤ 0.3	0	1	*																																																								
0.3 < D	0	0	*																																																								
Zone \ X (mm)	Zone \ Y (mm)	Acceptable Number																																																									
		A	B	C																																																							
--	0.03 ≥ W	*	*	*																																																							
2.0 ≥ L	0.05 ≥ W	3	3	*																																																							
1.0 ≥ L	0.1 ≥ W	3	3	*																																																							
--	0.1 < W	In the same way (1)																																																									
2.	Air Bubbles (between glass & polarizer)	<table border="1"> <thead> <tr> <th rowspan="2">Dimension (mm) \ Zone</th> <th colspan="3">Acceptable Number</th> </tr> <tr> <th>A</th> <th>B</th> <th>C</th> </tr> </thead> <tbody> <tr> <td>D ≤ 0.3</td> <td>*</td> <td>*</td> <td>*</td> </tr> <tr> <td>0.3 < D ≤ 0.4</td> <td>3</td> <td>*</td> <td>*</td> </tr> <tr> <td>0.4 < D ≤ 0.6</td> <td>2</td> <td>3</td> <td>*</td> </tr> <tr> <td>0.6 < D</td> <td>0</td> <td>0</td> <td>*</td> </tr> </tbody> </table> <p>*: Disregard</p> <p>Total defects shall not exceed 3.</p>	Dimension (mm) \ Zone	Acceptable Number			A	B	C	D ≤ 0.3	*	*	*	0.3 < D ≤ 0.4	3	*	*	0.4 < D ≤ 0.6	2	3	*	0.6 < D	0	0	*																																		
Dimension (mm) \ Zone	Acceptable Number																																																										
	A	B	C																																																								
D ≤ 0.3	*	*	*																																																								
0.3 < D ≤ 0.4	3	*	*																																																								
0.4 < D ≤ 0.6	2	3	*																																																								
0.6 < D	0	0	*																																																								

To be continued.....

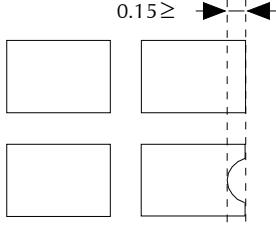
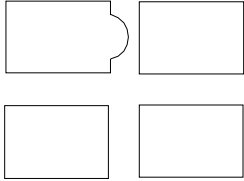
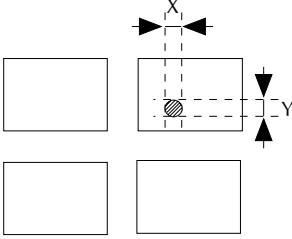
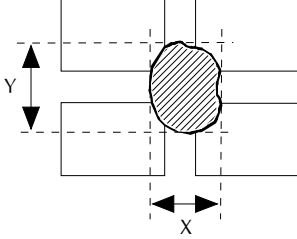

Messrs.					
Product Specification	Model:	MTB-F000368MNHNA	Rev. No.	Issued Date.	Page.
			A	Sep.29, 05	19 / 22

No.	Parameter	Criteria
3.	The Shape of Dot	<p>(1) Dot Shape (with Dent)</p>  <p>As per the sketch of left hand.</p> <p>(2) Dot Shape (with Projection)</p>  <p>Should not be connected to next dot.</p> <p>(3) Pin Hole</p>  <p>$(X+Y)/2 \leq 0.2\text{mm}$ (Less than 0.1mm is no counted.)</p> <p>(4) Deformation</p>  <p>$(X+Y)/2 \leq 0.2\text{mm}$</p> <p>Total acceptable number: 1/dot, 5/cell (Defect number of (4): 1pc.)</p>
4.	Polarizer Scratches	Not to be conspicuous defects.
5.	Polarizer Dirts	If the stains are removed easily from LCDP surface, the module is not defective.
6.	Complex Foreign Substance Defects	Black spots, line shaped foreign substance or air bubbles between glass & polarizer should be 5pcs maximum in total.
7.	Distance between different Foreign Substance defects	$D \leq 0.2$: 20mm or more $0.2 < D$: 40mm or more



Messrs.					
Product Specification	Model:	MTB-F000368MNHNA	Rev. No.	Issued Date.	Page.
			A	Sep.29, 05	20 / 22

8. Handling and Precautions

The Following precautions will guide you in handling our product correctly.

- 1 Liquid crystal display devices
 - 1.1 The liquid crystal display device panel used in the liquid crystal display module is made of plate glass. Avoid any strong mechanical shock. Should the glass break handle it with care.
 - 1.2 The polarizer adhering to the surface of the LCD is made of a soft material. Guard against scratching it.
- 2 Care of the liquid crystal display module against static electricity discharge.
 - 2.1 When working with the module, be sure to ground your body and any electrical equipment you may be using. We strongly recommend the use of anti static mats (made of rubber), to protect work tables against the hazards of electrical shock.
 - 2.2 Avoid the use of work clothing made of synthetic fibers. We recommend cotton clothing or other conductivity-treated fibers.
 - 2.3 Slowly and carefully remove the protective film from the LCD module, since this operation can generate static electricity.
- 3 When the LCD module alone must be stored for long periods of time:
 - 3.1 Protect the modules from high temperature and humidity.
 - 3.2 Keep the modules out of direct sunlight or direct exposure to ultra-violet rays.
 - 3.3 Protect the modules from excessive external forces.
- 4 Use the module with a power supply that is equipped with an over current protector circuit, since the module is not provided with this protective feature.
- 5 Do not ingest the LCD fluid itself should it leak out of a damaged LCD module. Should hands or clothing come in contact with LCD fluid, wash immediately with soap.
- 6 Conductivity is not guaranteed for models that use metal holders where solder connections between the metal holder and the PCB are not used. Please contact us to discuss appropriate ways to assure conductivity.



Messrs.					
Product Specification	Model:	MTB-F000368MNHNA	Rev. No.	Issued Date.	Page.
			A	Sep.29, 05	21 / 22

9. Warranty:

This product has been manufactured to your company's specifications as a part for use in your company's general electronic products. It is guaranteed to perform according to delivery specifications. For any other use apart from general electronic equipment, we cannot take responsibility if the product is used in medical devices, nuclear power control equipment, aerospace equipment, fire and security systems, or any other applications in which there is a direct risk to human life and where extremely high levels of reliability are required. If the product is to be used in any of the above applications, we will need to enter into a separate product liability agreement.

- 1 We cannot accept responsibility for any defect, which may arise from additional manufacturing of the product (including disassembly and reassembly), after product delivery.
- 2 We cannot accept responsibility for any defect, which may arise after the application of strong external force to the product.
- 3 We cannot accept responsibility for any defect, which may arise due to the application of static electricity after the product has passed your company's acceptance inspection procedures.
- 4 We cannot accept responsibility for industrial property, which may arise through the use of your product, with exception to those issues relating directly to the structure or method of manufacturing of our product. Microtips-origin longer than one year from Microtips production.

10. Dimensional Outlines

- See the next page.....



Microtips Technology Inc.

Messrs.

Product Specification

Model:

MTB-F000368MNHNA

Rev. No.

A

Issued Date.

Sep.29, 05

Page.

22 / 22

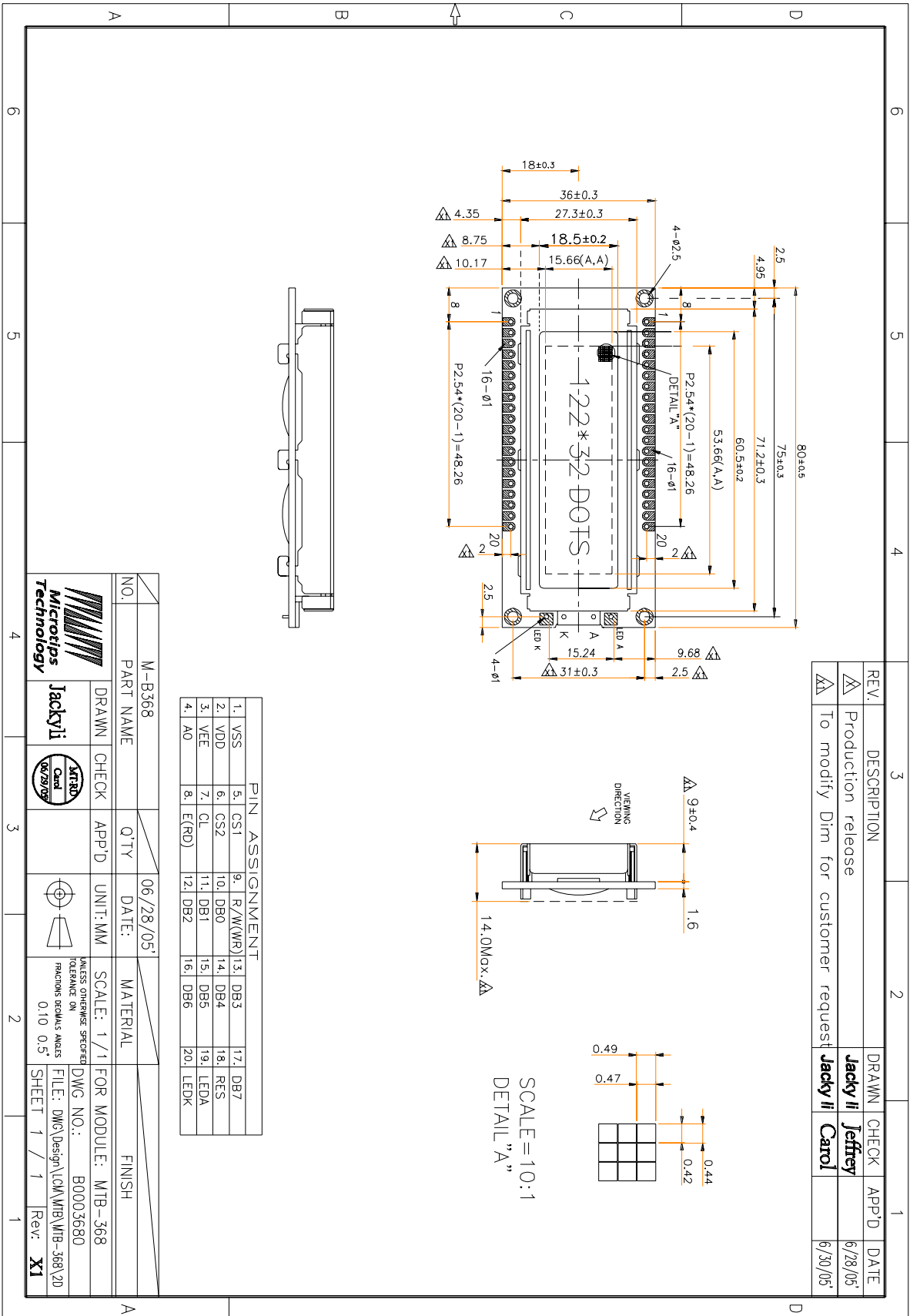

REV.	DESCRIPTION	DRAWN	CHECK	APP'D	DATE
1	Production release	Jacky Ji	Jeffrey		6/28/05
2	To modify Dim for customer request	Jacky Ji	Carol		6/30/05

NO.	M-B368	PART NAME	QTY	DATE:	06/28/05	MATERIAL	FINISH
DRAWN	Jacky Ji	CHECK	APP'D	UNIT:MM	SCALE: 1/1	FOR MODULE: MTB-368	
					UNLESS OTHERWISE SPECIFIED TOLERANCE ON FRACTIONS DECIMALS ANGLES 0.10 0.5°	DWG NO.: B0003680 FILE: DWG\Design\1CM\MTB\MTB-368_2D	
		SHEET 1 / 1		Rev: X1			



Microtips Technology Inc.