

40V N-Channel Enhancement Mode MOSFET

Description

The NP4008SR uses trench MOSFET technology that is uniquely optimized to provide the most efficient high frequency switching performance. Conduction and switching losses are minimized due to an extremely low combination of $R_{DS(ON)}$ and Cr_{ss} .

General Features

- ◆ $V_{DS} = 40V$ $I_D = 6A$
 $R_{DS(ON)}(Typ.) = 25m\Omega$ @ $V_{GS} = 10V$
 $R_{DS(ON)}(Typ.) = 31m\Omega$ @ $V_{GS} = 4.5V$
- ◆ Lead free product is acquired
- ◆ Surface mount package

Application

- ◆ High Frequency Point-of-Load Synchronous Buck Converter for MB/NB/UMPC/VGA
- ◆ Networking DC-DC Power System
- ◆ Load switch

Package

- ◆ SOP-8

100% UIS TESTED!
100% ΔV_{ds} TESTED!

Schematic diagram

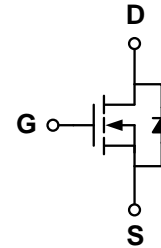

Marking and pin assignment

SOP-8

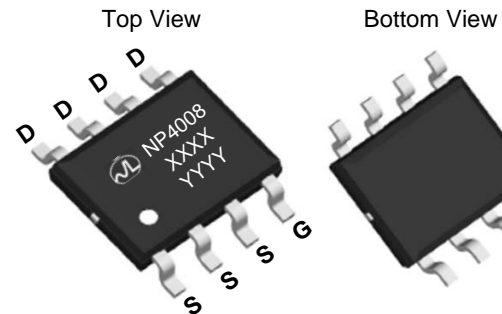

XXXX—Date Code
 YYYY—Quality Code.



Ordering Information

Part Number	Storage Temperature	Package	Devices Per Reel
NP4008SR-G	-55°C to +150°C	SOP-8	4000

Absolute Maximum Ratings (TA=25°C unless otherwise noted)

parameter	symbol	limit	unit
Drain-source voltage	V_{DS}	40	V
Gate-source voltage	V_{GS}	±20	V
Continuous Drain Current	I_D	TC=25°C	6
		TC=70°C	4
Pulsed Drain Current	I_{DP}	24	A
Avalanche energy(L=0.1mH)	E_{AS}	10	mJ
Power Dissipation	P_D	TC=25°C	3
		TC=70°C	2.1
Operating junction Temperature range	T_j	-55—150	°C

Electrical Characteristics (TA=25°C unless otherwise noted)

Parameter	Symbol	Condition	Min	Typ	Max	Unit
Static Characteristics						
Drain-source breakdown voltage	BV_{DSS}	$V_{GS}=0V, I_D=250\mu A$	40	-	-	V
Zero gate voltage drain current	I_{DSS}	$V_{DS}=40V, V_{GS}=0V$ $T_J=85^\circ C$	-	-	1	μA
			-	-	5	
Gate Leakage Current	I_{GSS}	$V_{DS}=0V, V_{GS}=\pm 20V$	-	-	± 100	nA
Gate threshold voltage	$V_{GS(th)}$	$V_{DS}=V_{GS}, I_D=250\mu A$	1.0	1.4	2.0	V
Drain-source on-state resistance ¹	$R_{DS(ON)}$	$V_{GS}=10V, I_D=6A$	-	25	28	m Ω
		$V_{GS}=4.5V, I_D=4A$		31	35	
On Status Drain Current	$I_{D(ON)}$	$V_{DS}=10V, V_{GS}=5V$	6	-	-	A
Diode Characteristics						
Diode Forward Voltage	V_{SD}	$I_{SD}=1A, V_{GS}=0V$	-	0.82	1.1	V
Diode Continuous Forward Current	I_S		-	-	2	A
Reverse Recovery Time	t_{rr}	$I_F=6A,$	-	18	-	ns
Reverse Recovery Charge	Q_{rr}	$di/dt=100A/\mu s$	-	10	-	nC
Dynamic Characteristics						
Gate Resistance	R_G	$V_{GS}=0V, V_{DS}=0V, f=1MHz$	-	4.6	-	Ω
Input capacitance	C_{ISS}	$V_{GS}=0V, V_{DS}=20V$ $f=1.0MHz$	-	516	-	pF
Output capacitance	C_{OSS}		-	82	-	
Reverse transfer capacitance	C_{RSS}		-	43	-	
Turn-on delay time	$t_{D(ON)}$	$V_{GS}=10V, V_{DS}=20V, R_L=1\Omega,$ $R_G=3\Omega$	-	6.4	-	ns
Turn-on Rise time	t_r		-	3.6	-	
Turn-off delay time	$t_{D(OFF)}$		-	16.2	-	
Turn-off Fall time	t_f		-	6.6	-	
Total gate charge	Q_g	$V_{GS}=10V, V_{DS}=15V, I_D=13A$	-	8.9	-	nC
Gate-source charge	Q_{gs}		-	2.4	-	
Gate-drain charge	Q_{gd}		-	1.4	-	

Thermal Characteristics

Parameter	Symbol	Typ	Max	Unit
Maximum Junction-to-Ambient ^A	$\leq 10s$	33	40	$^\circ C/W$
Maximum Junction-to-Ambient ^A	Steady-State			
Maximum Junction-to-Lead ^B	Steady-State	16	24	

A: The value of R_{qJA} is measured with the device mounted on 1in 2 FR-4 board with 2oz. Copper, in a still air environment with $T_A=25^\circ C$. The value in any given application depends on the user's specific board design. The current rating is based on the $t \leq 10s$ thermal resistance rating.

B: The R_{qJA} is the sum of the thermal impedance from junction to lead R_{qJL} and lead to ambient.

Package Information

- SOP-8

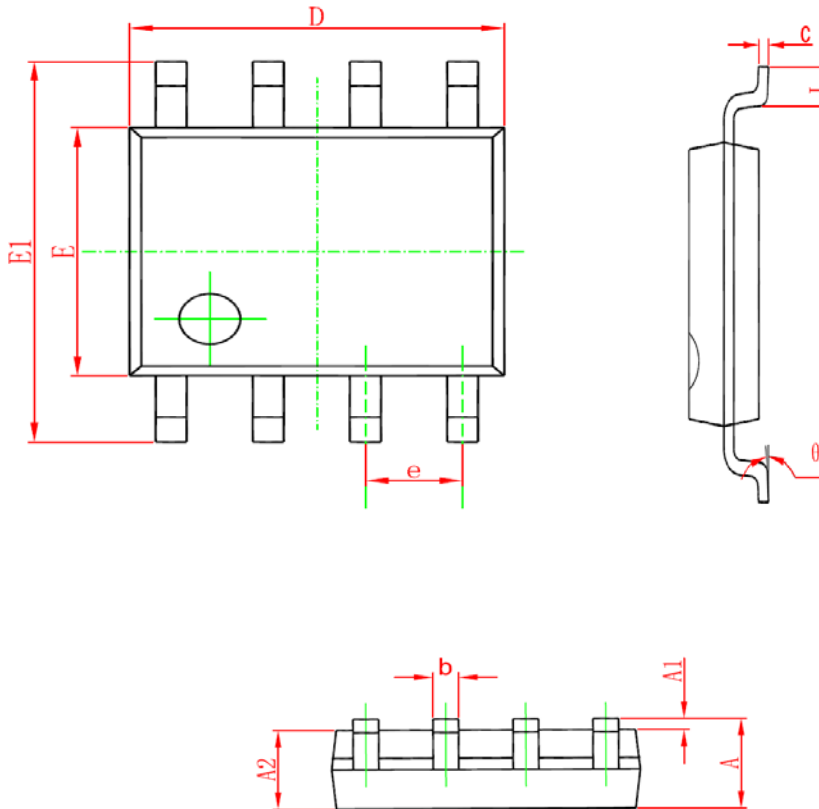

Symbol	Dimensions In Millimeters		Dimensions In Inches	
	Min	Max	Min	Max
A	1.350	1.750	0.053	0.069
A1	0.100	0.250	0.004	0.010
A2	1.350	1.550	0.053	0.061
b	0.330	0.510	0.013	0.020
c	0.170	0.250	0.006	0.010
D	4.700	5.100	0.185	0.200
E	3.800	4.000	0.150	0.157
E1	5.800	6.200	0.228	0.244
e	1.270 (BSC)		0.050 (BSC)	
L	0.400	1.270	0.016	0.050
θ	0°	8°	0°	8°

Recommended Minimum Pads

- SOP-8

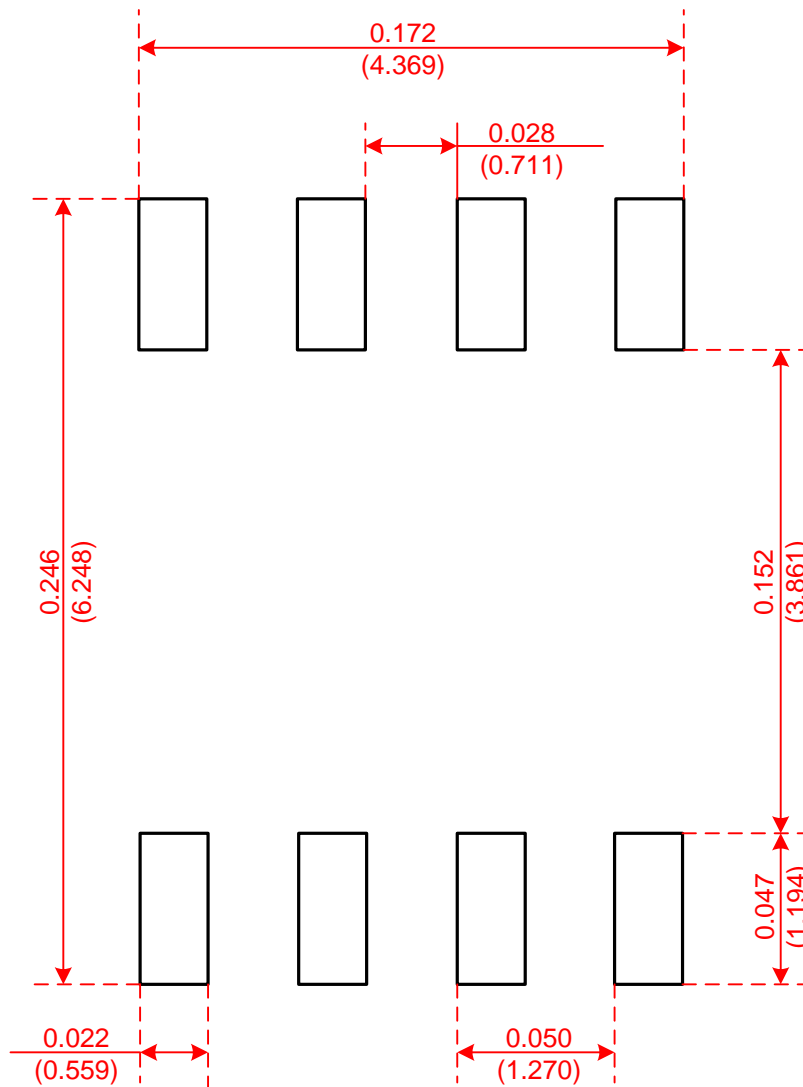

**Recommended Minimum Pads
Dimensions in Inches/(mm)**

Tape and Reel

- SOP-8

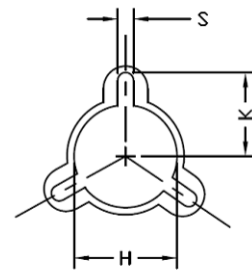
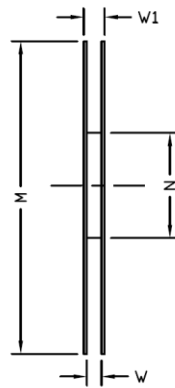
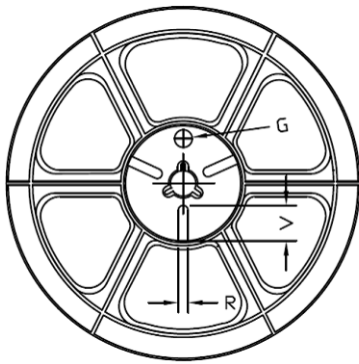
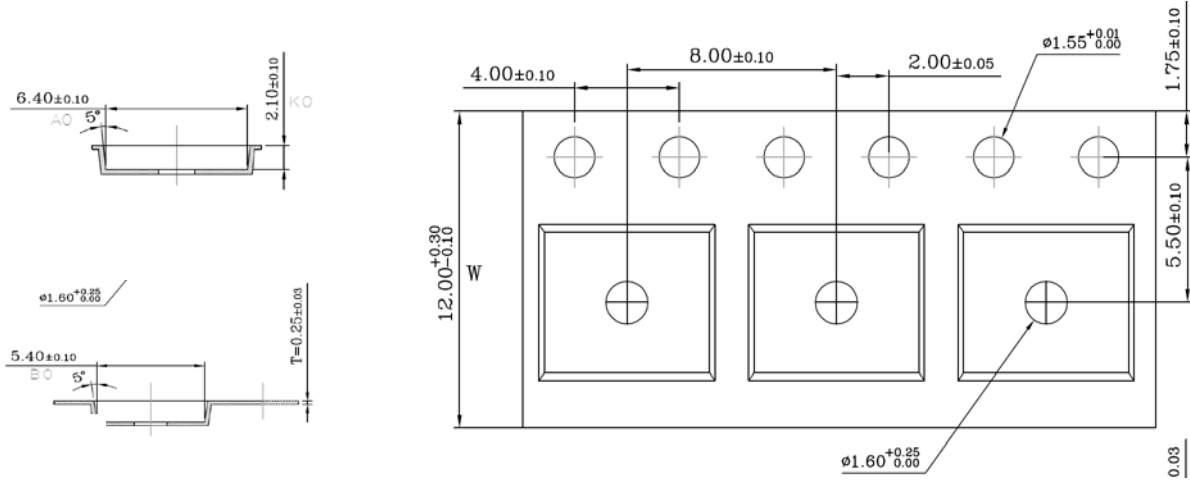

Tape Size	Reel Size	M	N	W	W1	H	K	S	G	R	V
12mm	$\phi 330$	$\phi 330.00$ ± 0.50	$\phi 97.00$ ± 0.30	13.00 ± 0.30	17.40 ± 1.00	$\phi 13.00$ ± 0.5	10.6	2.00 ± 0.50	—	—	—

Unit Per Reel:
4000pcs

