

30V N And P-Channel Enhancement Mode MOSFET

Description

The NP4606G uses advanced trench technology to provide excellent $R_{DS(ON)}$ and low gate charge. The complementary MOSFETs may be used to form a level shifted high side switch, and for a host of other applications.

General Features

◆ N-channel:

$V_{DS} = 30V$, $I_D = 12A$

$R_{DS(ON)} = 17m\Omega$ (typical) @ $V_{GS} = 10V$

$R_{DS(ON)} = 25m\Omega$ (typical) @ $V_{GS} = 4.5V$

P-Channel:

$V_{DS} = -30V$, $I_D = -12A$

$R_{DS(ON)} = 28m\Omega$ (typical) @ $V_{GS} = -10V$

$R_{DS(ON)} = 36m\Omega$ (typical) @ $V_{GS} = -4.5V$

- ◆ Excellent gate charge x $R_{DS(ON)}$ product(FOM)
- ◆ Very low on-resistance $R_{DS(ON)}$
- ◆ 150 °C operating temperature
- ◆ Pb-free lead plating
- ◆ 100% UIS tested

Application

- ◆ DC/DC Converter
- ◆ Ideal for high-frequency switching and synchronous rectification

Schematic diagram

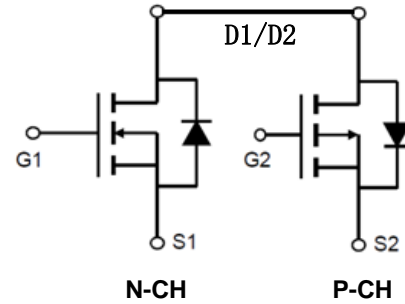

Marking and pin assignment

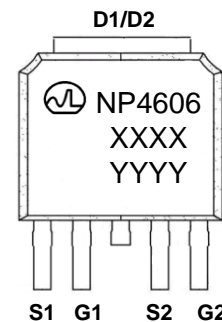

XXXX—Wafer Information

YYYY—Quality Code

Ordering Information

Part Number	Storage Temperature	Package	Devices Per Reel
NP4606G-G	-55°C to +150°C	TO252-4L	2500

Absolute Maximum Ratings (TA=25°C unless otherwise noted)

Parameter	Symbol	Limit		Unit
		N	P	
Drain-source voltage	V_{DS}	30	-30	V
Gate-source voltage	V_{GS}	±20	±20	V
Operating junction Temperature range	T_j	-55—150	-55—150	°C
Drain Current-Continuous	I_D	12	-12	A

(Silicon Limited)	$T_A=70^\circ\text{C}$		9	-9	
Pulsed Drain Current (Package Limited)		I_{DM}	50	-50	A
Avalanche Current ^C		I_{AS}, I_{AR}	22	-27	A
Avalanche energy $L=0.1\text{mH}^C$		E_{AS}, E_{AR}	24	36	mJ
Power Dissipation ^B	$T_A=25^\circ\text{C}$	P_D	15.6	31	W
	$T_A=100^\circ\text{C}$		6.2	12.5	
Junction and Storage Temperature Range		T_J, T_{STG}	-55—150		$^\circ\text{C}$

Thermal Characteristics

Parameter		Symbol	Device	Typ	Max	Unit
Maximum Junction-to-Ambient ^A	$\leq 10\text{s}$	$R_{\theta JA}$	n-ch	20	28	$^\circ\text{C/W}$
Maximum Junction-to-Ambient ^A	Steady-State		n-ch	45	60	
Maximum Junction-to-Lead ^B	Steady-State	$R_{\theta JC}$	n-ch	6	8	
Maximum Junction-to-Ambient ^A	$\leq 10\text{s}$	$R_{\theta JA}$	p-ch	15	20	
Maximum Junction-to-Ambient ^A	Steady-State		p-ch	35	45	
Maximum Junction-to-Lead ^B	Steady-State	$R_{\theta JC}$	p-ch	3	4	

A: The value of $R_{\theta JA}$ is measured with the device mounted on 1in 2 FR-4 board with 2oz. Copper, in a still air environment with $T_A=25^\circ\text{C}$. The value in any given application depends on the user's specific board design. The current rating is based on the $t \leq 10\text{s}$ thermal resistance rating.

B: The $R_{\theta JA}$ is the sum of the thermal impedance from junction to lead $R_{\theta JL}$ and lead to ambient.

N-Channel Electrical Characteristics ($T_J=25^{\circ}\text{C}$ unless otherwise noted)

Parameter	Symbol	Condition	Min	Typ	Max	Unit
OFF Characteristics						
Drain-source breakdown voltage	BV_{DSS}	$V_{GS}=0V, I_D=250\mu A$	30	-	-	V
Zero gate voltage drain current	I_{DSS}	$V_{DS}=30V, V_{GS}=0V$	-	-	1	μA
Gate-body leakage	I_{GSS}	$V_{DS}=0V, V_{GS}=\pm 20V$	-	-	± 100	nA
ON Characteristics						
Gate threshold voltage	$V_{GS(th)}$	$V_{DS}=V_{GS}, I_D=250\mu A$	1.0	1.7	2.5	V
Drain-source on-state resistance	$R_{DS(on)}$	$V_{GS}=10V, I_D=10A$	-	17	28	m Ω
		$V_{GS}=4.5V, I_D=10A$	-	25	40	
Forward transconductance	gfs	$V_{DS}=5V, I_D=10A$	-	15	-	S
Dynamic Characteristics						
Input capacitance	C_{ISS}	$V_{DS}=15V, V_{GS}=0V$ $f=1.0\text{MHz}$	-	544	-	pF
Output capacitance	C_{OSS}		-	66	-	
Reverse transfer capacitance	C_{RSS}		-	50	-	
Gate resistance	R_g	$V_{GS}=0V, V_{DS}=0V,$ $f=1.0\text{MHz}$	-	2.8	-	Ω
Switching Characteristics						
Turn-on delay time	$t_{D(on)}$	$V_{DS}=15V$ $V_{GS}=10V$ $R_L=1.8\Omega$ $R_{GEN}=3\Omega$	-	4	-	ns
Rise time	tr		-	3	-	
Turn-off delay time	$t_{D(off)}$		-	15	-	
Fall time	tf		-	2	-	
Total gate charge	Qg	$V_{DS}=15V, I_D=10A$ $V_{GS}=10V$	-	11.3	-	nC
Gate-source charge	Qgs		-	2.7	-	
Gate-drain charge	Qgd		-	1.5	-	

Typical Performance Characteristics

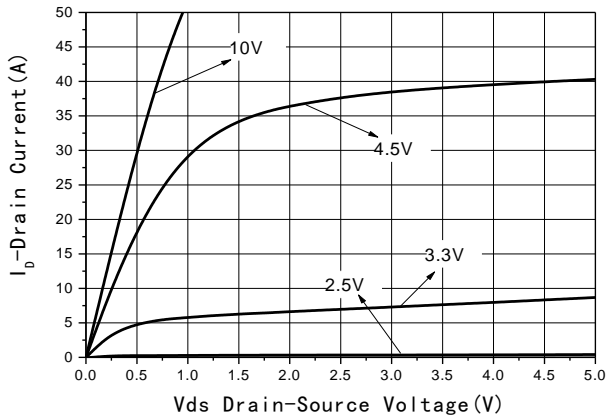

Fig1 Output Characteristics

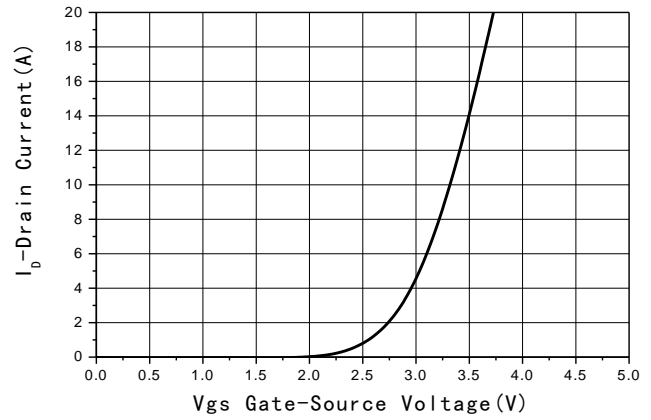

Fig2 Transfer Characteristics

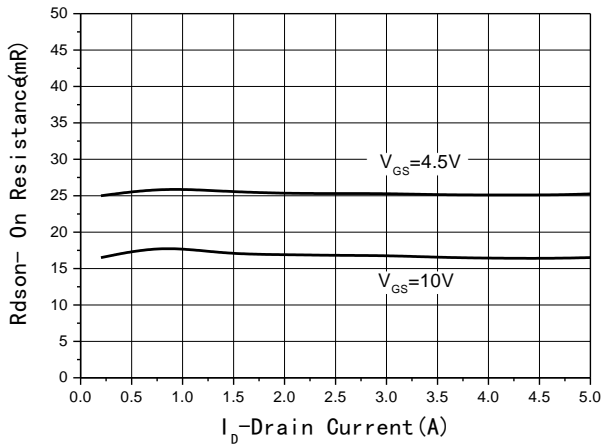

Fig3 $R_{DS(on)}$ -Drain current

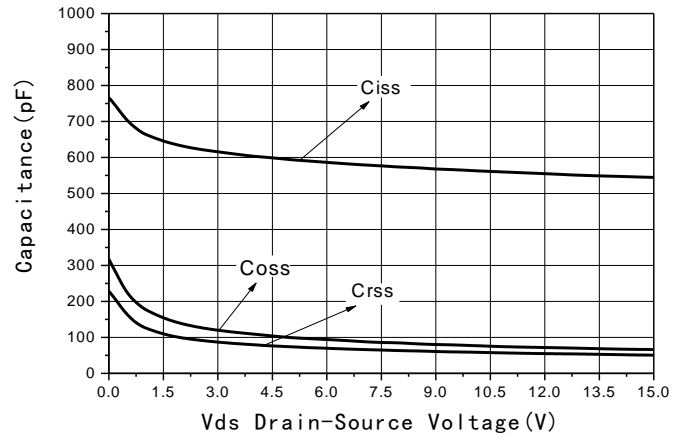

Fig4 Capacitance vs V_{DS}

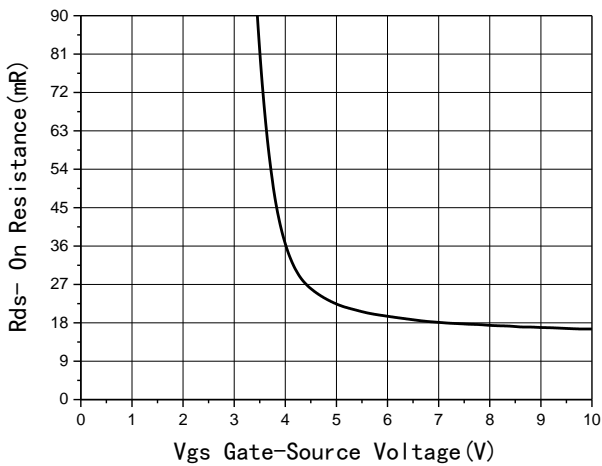

Fig5 $R_{DS(on)}$ -Gate Drain voltage

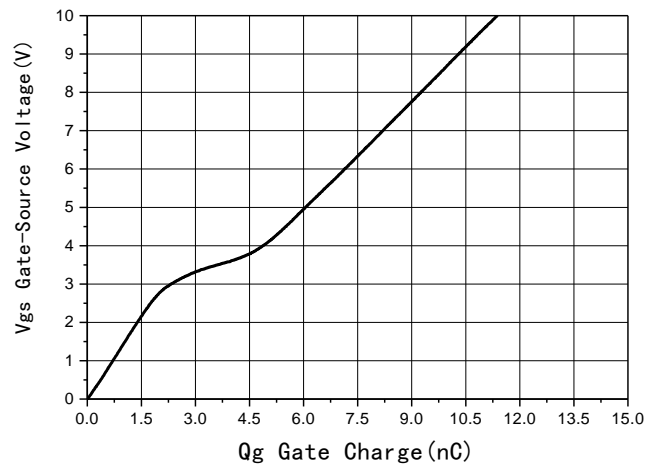
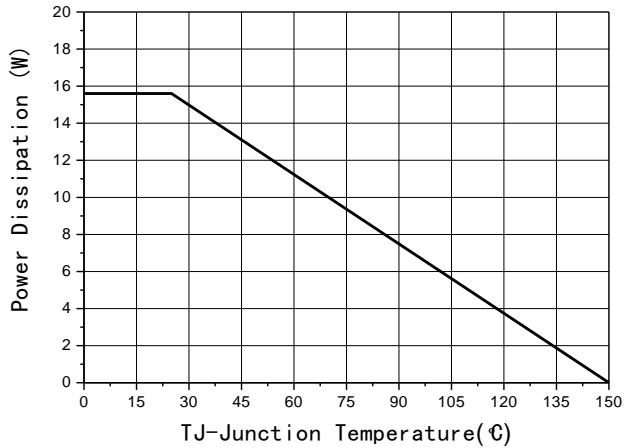
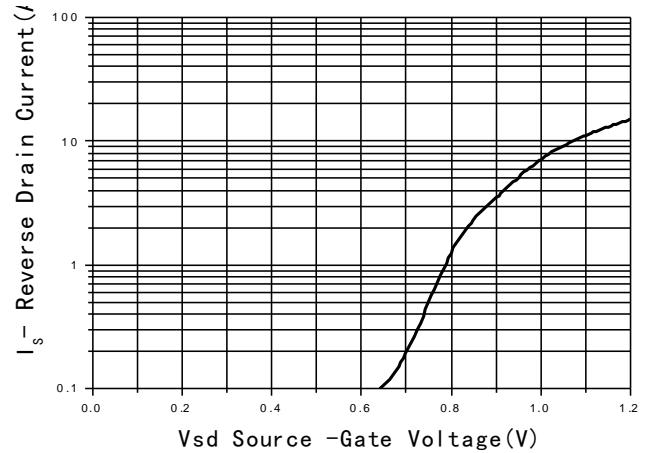

Fig6 Gate Charge

Fig7 Power De-rating

Fig8 Source-Drain Diode Forward

P-Channel Electrical Characteristics (T_J=25°C unless otherwise noted)

Parameter	Symbol	Condition	Min	Typ	Max	Unit
OFF Characteristics						
Drain-source breakdown voltage	BV _{DSS}	V _{GS} =0V, I _D =-250μA	-30	-	-	V
Zero gate voltage drain current	I _{DSS}	V _{DS} =-30V, V _{GS} =0V	-	-	-1	μA
Gate-body leakage	I _{GSS}	V _{DS} =0V, V _{GS} =±20V	-	-	±100	nA
ON Characteristics						
Gate threshold voltage	V _{GS(th)}	V _{DS} =V _{GS} , I _D =-250μA	-1.0	-1.35	-2.5	V
Drain-source on-state resistance	R _{DS(ON)}	V _{GS} =-10V, I _D =-10A	-	28	32	mΩ
		V _{GS} =-4.5V, I _D =-10A	-	36	42	
Forward transconductance	g _{fs}	V _{DS} =-5V, I _D =-10A	-	18	-	S
Dynamic Characteristics						
Input capacitance	C _{ISS}	V _{DS} =-15V, V _{GS} =0V f=1.0MHz	-	911	-	pF
Output capacitance	C _{OSS}		-	94	-	
Reverse transfer capacitance	C _{RSS}		-	82	-	
Gate resistance	R _g	V _{GS} =0V, V _{DS} =0V, f=1.0MHz	-	4	-	Ω
Switching Characteristics						
Turn-on delay time	t _{D(ON)}	V _{DS} =-15V V _{GS} =-10V R _L =2.3Ω R _{GEN} =3Ω	-	10	-	ns
Rise time	t _r		-	5.5	-	
Turn-off delay time	t _{D(OFF)}		-	3.6	-	
Fall time	t _f		-	4.6	-	
Total gate charge	Q _g	V _{DS} =-15V, I _D =-10A V _{GS} =-10V	-	18.7	-	nC
Gate-source charge	Q _{gs}		-	3.8	-	
Gate-drain charge	Q _{gd}		-	2.6	-	

Typical Performance Characteristics

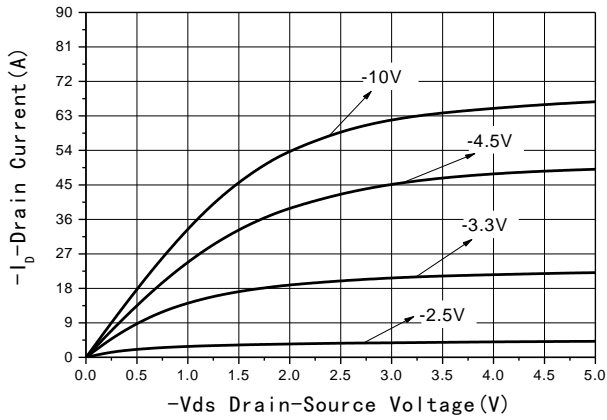

Fig1 Output Characteristics

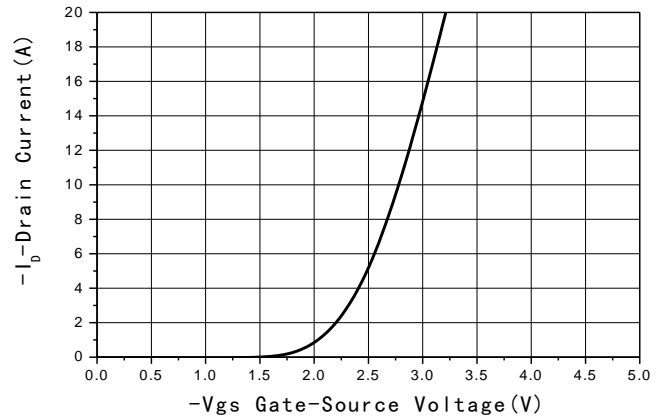

Fig2 Transfer Characteristics

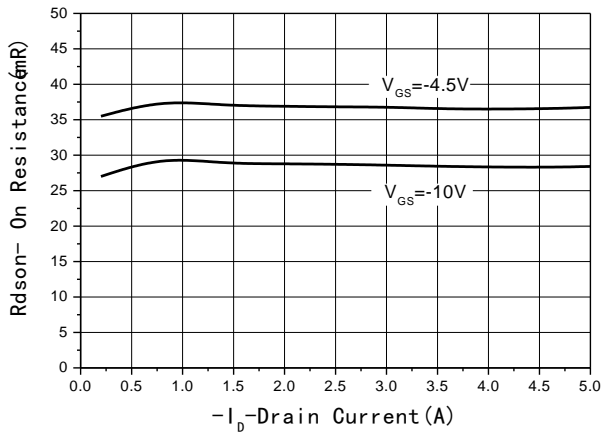

Fig3 $R_{DS(on)}$ -Drain current

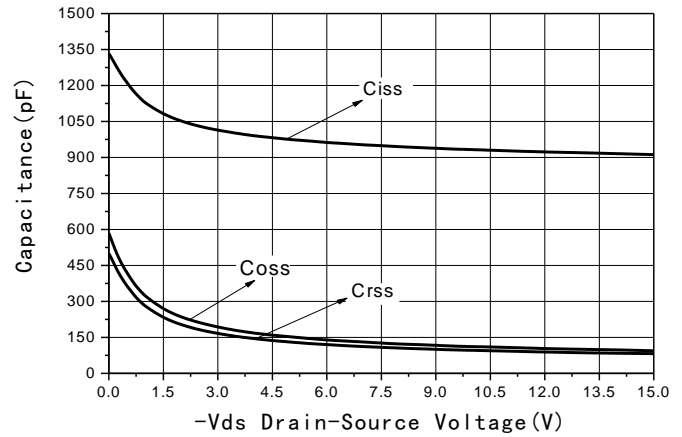

Fig4 Capacitance vs V_{DS}

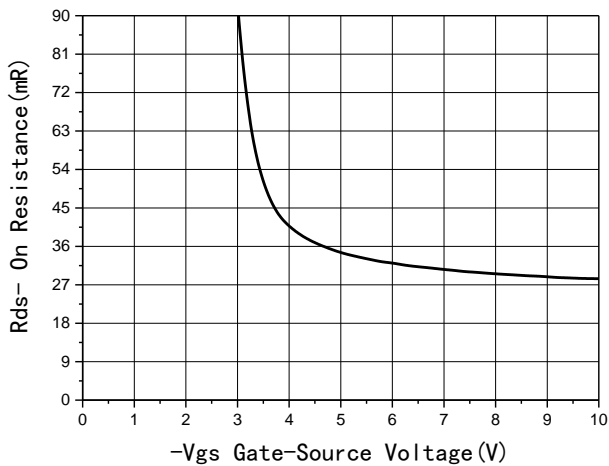

Fig5 $R_{DS(on)}$ -Gate Drain voltage

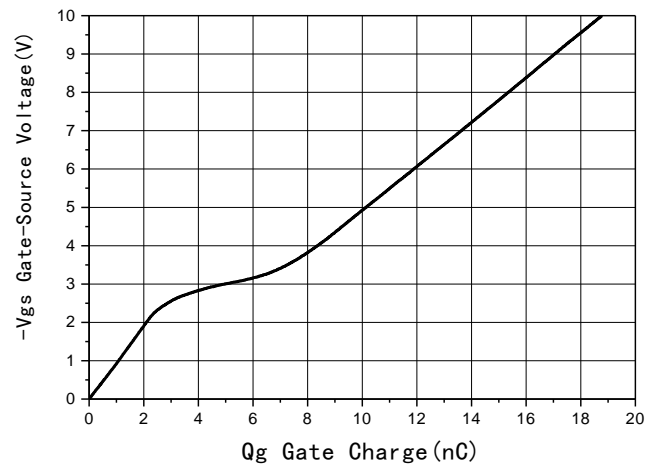

Fig6 Gate Charge

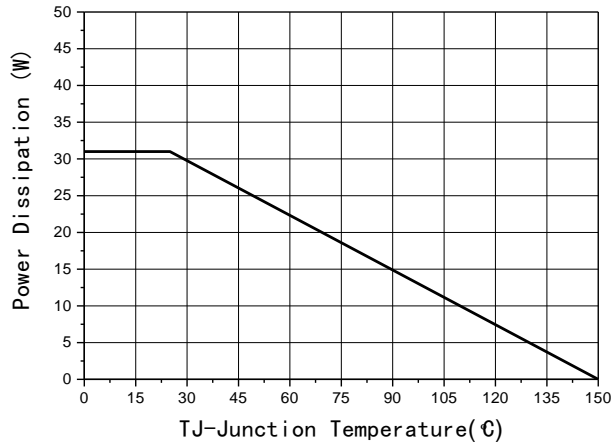

Fig7 Power De-rating

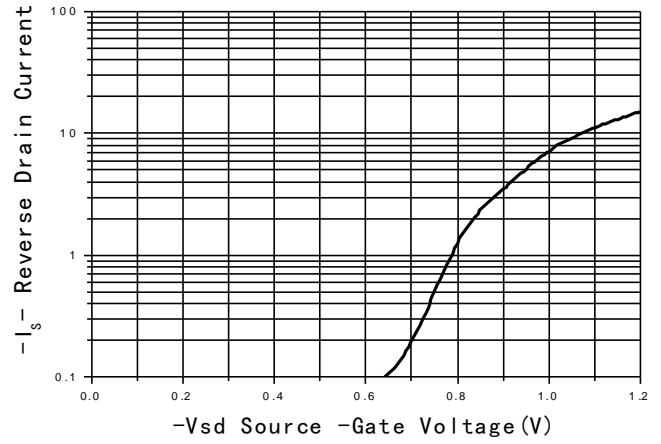
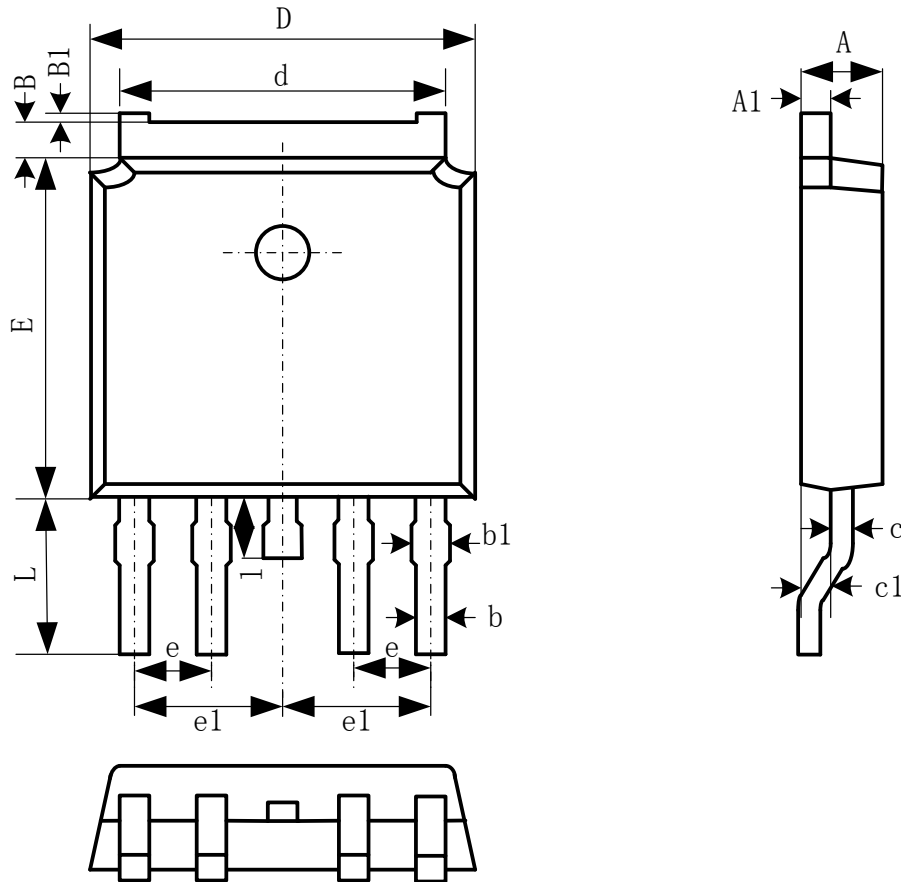

Fig8 Source-Drain Diode Forward

Package Information

- TO252-4L



Symbol	Dimensions In Millimeters		Dimensions In Inches	
	Min.	Max.	Min.	Max.
A	2.25	2.35	0.09	0.094
A1	0.503	0.513	0.0201	0.0205
B	0.962	0.162	0.0385	0.0065
B1	0.05 REF		0.002 REF	
c	0.503	0.513	0.0201	0.0205
c1	0.96	1.06	0.038	0.042
D	6.55	6.65	0.262	0.266
d	5.234	5.434	0.209	0.217
E	6.05	6.15	0.242	0.246
e	1.27 REF		0.05 REF	
e1	2.54REF		0.101REF	
L	2.698	2.998	0.1079	0.1199
l	0.7	0.9	0.028	0.036