



NEC's  $\phi 50\mu\text{m}$   
**InGaAs APD WITH INTERNAL  
 PREAMPLIFIER IN COAXIAL PACKAGE  
 FOR 2.5 Gb/s APPLICATIONS**

**NR4500BP-CC  
 NR4500CP-CC**

## FEATURES

- **HIGH DATA RATE CAPABILITY:**  
2.5 Gbps
- **RECEIVER SENSITIVITY:**  
 $\bar{P}_{\text{LOW}} = -32 \text{ dBm}$
- **APD WITH HIGH PERFORMANCE GaAs  
PRE-AMPLIFIER**
- **OPERATING CASE TEMPERATURE RANGE:**  
 $T_c = 0 \text{ to } +85^\circ\text{C}$
- **COAXIAL MODULE WITH SC-UPC CONNECTOR**
- **SINGLE-END OUTPUT**

## DESCRIPTION

NEC's NR4500BP-CC and NR4500CP-CC are 2.5-Gbp/s APD receivers in a coaxial module with an internal pre-amplifier.

These modules are ideal as receivers for Synchronous Digital Hierarchy (SDH) system, STM-16, ITU-T recommendations.

## ELECTRO-OPTICAL CHARACTERISTICS, ( $T_c = 25^\circ\text{C}$ , unless otherwise specified)

PART NUMBER			NR4500BP-CC NR4500CP-CC		
SYMBOLS	PARAMETERS AND CONDITIONS	UNITS	MIN	TYP	MAX
$V_{BR}$	Reverse Break Down Voltage, $I_D = 100 \mu\text{A}$	V	40	60	80
$\delta$	Temperature Coefficient of Reverse Breakdown Voltage $T_c = 0 \text{ to } +85^\circ\text{C}$	$\%/^\circ\text{C}$	0.15		0.22
$\bar{P}_{\text{LOW}}$	Receiver Sensitivity, 2.488320 Gbps, BER $10^{-10}$ , PRBS $2^{23}-1$ , Mark = 1/2, NRZ, $M(v_R)$ is set at opt. value	dBm		-32	-31
	$T_c = 0 \text{ to } +85^\circ\text{C}$			-31	
$\bar{P}_{\text{HIGH}}$	Maximum Optical Input Power, 2.488320 Gbps, BER = $10^{-10}$ , PRBS = $2^{23}-1$ , Mark = 1/2, NRZ, $M(v_R)$ is set at optimum value	dBm	-7		
	$T_c = 0 \text{ to } +85^\circ\text{C}$			-8	
S	Sensitivity, $M = 1, \lambda = 1310 \text{ nm}$ $M = 1, \lambda = 1550 \text{ nm}$	A/W	0.80	0.94	
			0.81	0.96	
$f_c$	Cut-off Frequency, AC Coupling, $R_L = 50 \Omega$ , $P_{IN} = -30 \text{ dBm}$ , $M = 10^1$	GHz	1.8		
ORL	Optical Return Loss, $\lambda = 1310 \text{ nm}$ , $\lambda = 1550 \text{ nm}$	dB	30		
$Z_t$	Trans Impedance, AC coupling, $R_L = 50 \Omega$ , $f = 100 \text{ MHz}$ $P_{IN} \leq -20 \text{ dBm}$	$\Omega$	400	600	
$V_{SS}$	Supply Voltage	V	-5.46	-5.20	-4.96
$I_{SS}$	Supply Current, $V_{SS} = -5.2 \text{ V}$	mA			45

Note:

1. -3 dB point from 3 MHz

# NR4500BP-CC, NR4500CP-CC

## ABSOLUTE MAXIMUM RATINGS<sup>1</sup>

(T<sub>c</sub> = 25°C, unless otherwise specified)

SYMBOLS	PARAMETERS	UNITS	RATINGS
I <sub>F</sub>	Forward Current	mA	10
I <sub>R</sub>	Reverse Current	mA	1.0
V <sub>SS</sub>	Supply Voltage	V	-6.0
T <sub>c</sub>	Operating Case Temperature	°C	0 to +85
T <sub>STG</sub>	Storage Temperature	°C	-40 to +85
T <sub>SLD</sub>	Lead Soldering Temperature (10 sec)	°C	260
RH	Relative Humidity (noncondensing)	%	85

Note:

- Operation in excess of any one of these parameters may result in permanent damage.

## ORDERING INFORMATION

PART NUMBER	AVAILABLE CONNECTOR	DESCRIPTION
NR4500BP-CC	With SC-UPC Connector	Flat Mount Flange
NR4500CP-CC		Vertical Flange

## OPTICAL FIBER CHARACTERISTICS

PARAMETER	SPEC	UNIT
Mode Field Diameter	9.5±1	μm
Cladding Diameter	125±2	μm
Maximum Cladding Noncircularity	2	%
Maximum Core/Cladding Concentricity	1.6	%
Outer Diameter	0.9±0.1	mm
Cut-off Wavelength	1100 to 1270	nm
Minimum Fiber Bending Radius	30	mm
Fiber Length	1000 MIN	mm
Flammability	UL1581 VW-1	

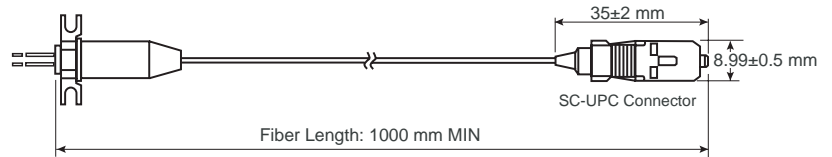

## TYPICAL PERFORMANCE CURVES (T<sub>A</sub> = 25°C)

FREQUENCY RESPONSE

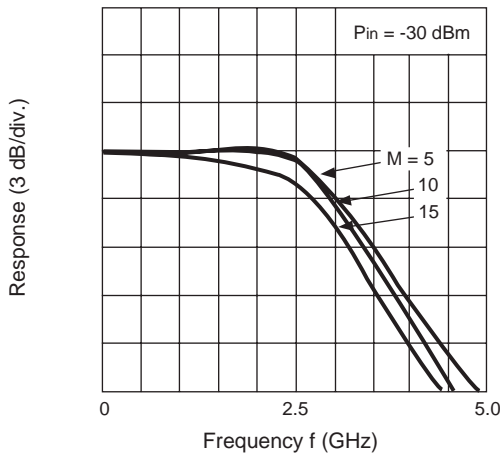

SENSITIVITY vs. MULTIPLICATION FACTOR

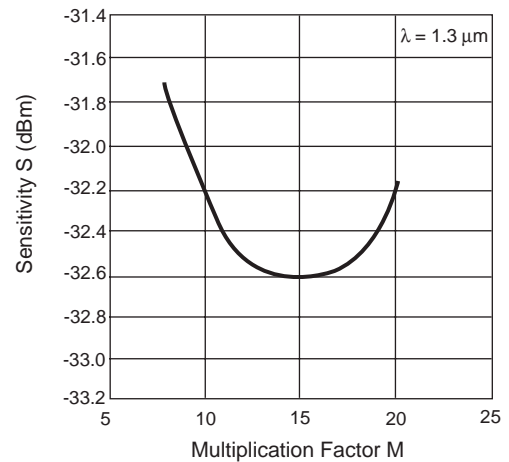

OUTPUT VOLTAGE vs. PHOTO CURRENT AVERAGE

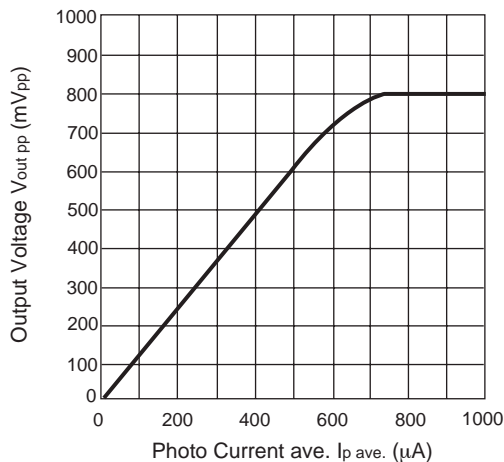

ERROR CHARACTERISTICS

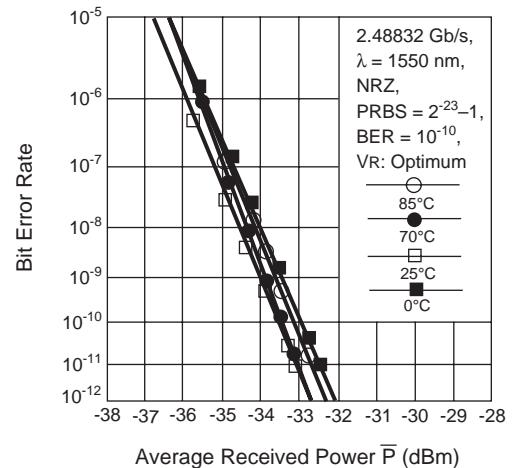

TYPICAL PERFORMANCE CURVES (TA = 25°C)

EYE DIAGRAM

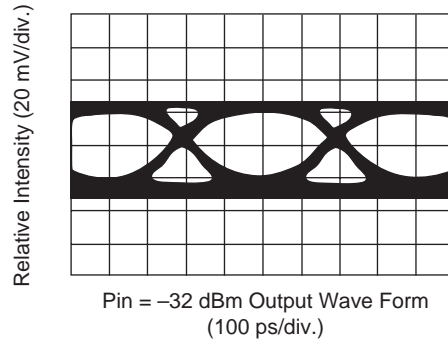
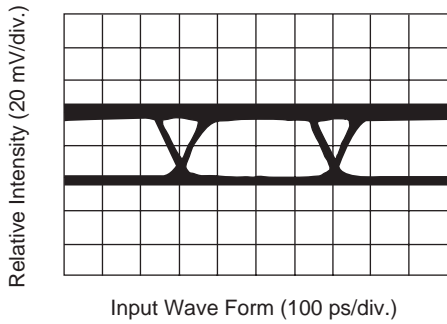

Remark: The graphs indicate nominal characteristics.

OUTLINE DIMENSIONS (Units in mm)

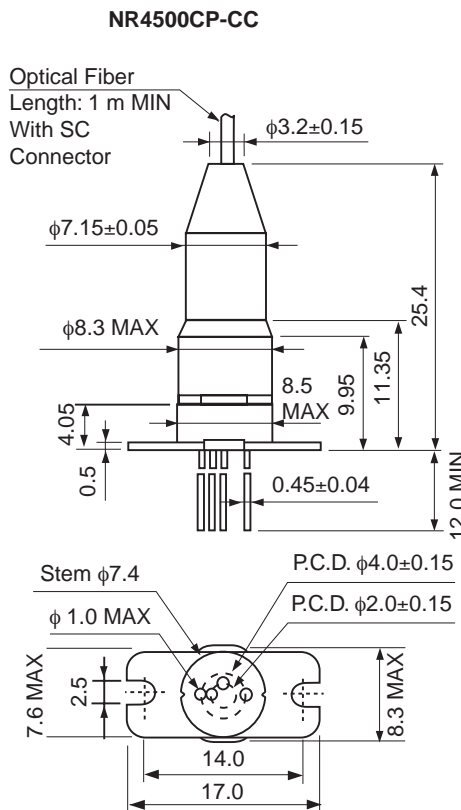
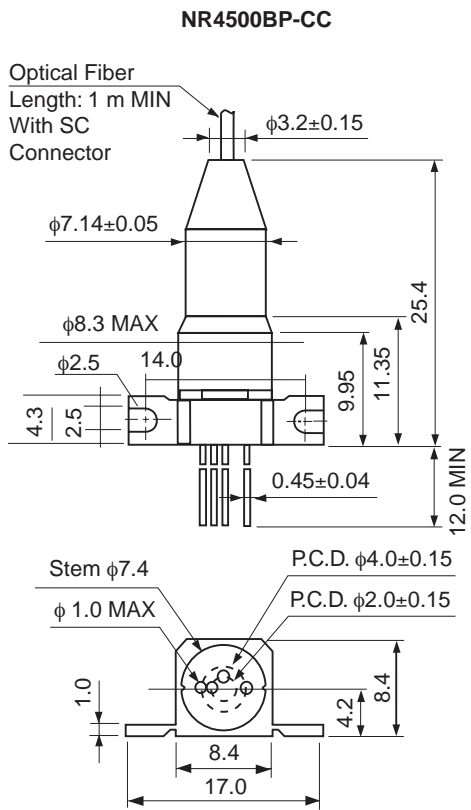

BOTTOM VIEW

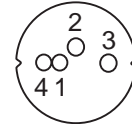

PIN CONNECTIONS

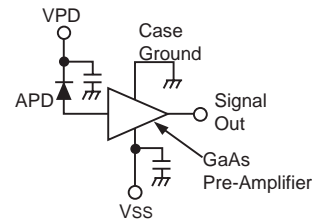

PIN CONNECTIONS

Pin No.	Function
1	VPD (APD Cathode)
2	Vss (-5.2 V)
3	Signal Out
4	Case Ground

Life Support Applications

These NEC products are not intended for use in life support devices, appliances, or systems where the malfunction of these products can reasonably be expected to result in personal injury. The customers of CEL using or selling these products for use in such applications do so at their own risk and agree to fully indemnify CEL for all damages resulting from such improper use or sale.

**CEL** California Eastern Laboratories, Your source for NEC RF, Microwave, Optoelectronic, and Fiber Optic Semiconductor Devices.

4590 Patrick Henry Drive • Santa Clara, CA 95054-1817 • (408) 988-3500 • FAX (408) 988-0279 • www.cel.com

DATA SUBJECT TO CHANGE WITHOUT NOTICE

02/27/2003