

NS4150B 3W Mono Class D Audio Amplifier

1 Features

- Operating voltage: 3.0- 5.0V.
- Output power: 2.8W(5V/4Ω, THD=10%).
- 0.1% THD(0.5W/3.6V).
- Efficiency up to 88%.
- High PSRR (80dB at 217Hz).
- Filterless Class D structure.
- Excellent full bandwidth EMI suppression capability.
- Excellent power on and power off noise suppression.
- Low quiescent current: 4mA (VDD=3.6V, No load).
- Overcurrent protection, overheat protection and under voltage protection.
- MSOP8 packages are available.

2 Applications

- Pads.
- Automobile data recorders.
- Bluetooth speakers.

4 Typical application circuit

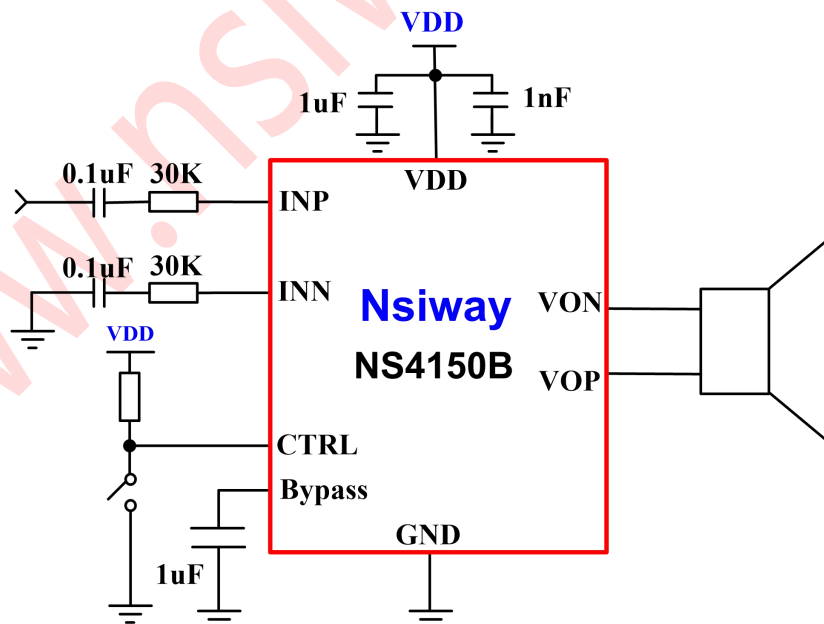

3 Description

The NS4150B is a Low EMI, filterless, 3W mono Class D audio amplifier. NS4150B uses advanced technology to greatly reduce EMI interference in the full bandwidth range, minimizing the impact on other components.

NS4150B has overcurrent protection, overheat protection and under voltage protection functions, effectively protect the chip from being damaged in abnormal working conditions. Using spread spectrum technology to fully optimize the new circuit design, up to 90% efficiency is more suitable for portable audio products.

The NS4150B's filterless PWM modulation structure and gain built-in mode reduce external components, PCB area and system cost.

The NS4150B is available in SOP8 and MSOP8 packages and is rated for operating temperatures ranging from -40 °C to 85 °C.

5 Pin Configuration

Pins of MSOP-8 are shown as follows.

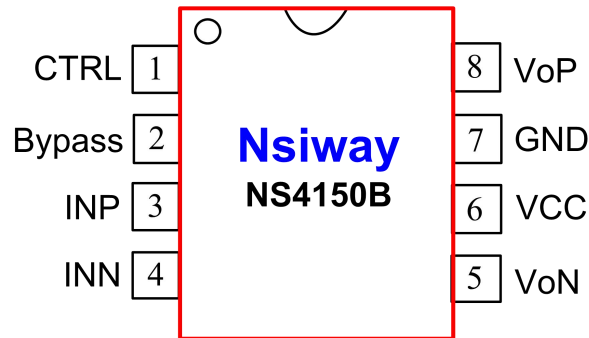

Pin NO.	Pin Name	Description
1	CTRL	Operating control, shutdown at low level.
2	Bypass	Internal common mode voltage bypass capacitor pin, connect 1uF capacitor to GND
3	INP	Audio positive input
4	INN	Audio negative input
5	VoN	Audio negative output
6	VCC	Power supply input and power pin of audio power tube
7	GND	Ground
8	VoP	Audio positive output

6 Absolute Maximum Ratings

parameter	Min.	Max.	Unit	Note
Supply voltage VDD	-0.3	5.25	V	
INP/INN/CTRL PIN	-0.3	VDD+0.3		
Storage temperature	-65	150	°C	
ESD withstand voltage	±4000		V	
Junction temperature		150	°C	
Recommended operating temperature	-40	85	°C	
Recommended operating voltage	2.2	5.0		
thermal resistance				
θ_{JC} (MSOP-8)		190	°C/W	
Latch up		±150	mA	
welding temperature		220	°C	15 秒内

Note: Exceeding the limit operating parameters may cause permanent damage to the chip. Prolonged exposure to

any of these limiting conditions may affect the reliability and longevity of the chip.

7 Electrical characteristics

Operating conditions (unless otherwise specified) : T=25°C, VDD=4.8V.

symbol	parameter	test conditions	Min.	Typ.	Max.	unit
V _{DD}	Supply Voltage		3.0	4.8	5.0	V
I _{DD}	Quiescent power current	V _{IN} =0V, V _{DD} =3.6V, No Load		4.0		mA
I _{SD}	Turn off leakage current	V _{DD} =3.6V, CTRL=0V		1	10	μA
V _{OS}	Output offset voltage	V _{IN} =0V, V _{DD} =3.0V to 5.0V		5	20	mV
f _{SW}	Modulation frequency	V _{DD} =3.0V to 5.0V		400		kHz
P _O	Output power	THD=1%, f=1kHz, V _{DD} =5V R _L =4Ω R _L =8Ω		2.0 1.3		W
		THD=10%, f=1kHz, V _{DD} =5V R _L =4Ω R _L =8Ω		2.8 1.7		W
THD+N	Total distortion + noise	V _{DD} =3.6V, f=1kHz, R _L =8Ω, P _O =0.1W		0.15		%
		V _{DD} =3.6V, f=1kHz, R _L =4Ω, P _O =0.5W		0.10		%
PSRR	Power supply rejection ratio	217Hz 20KHz		-80 -72		dB
CMRR	Common mode rejection ratio			-70		dB
η	Efficiency	V _{DD} =3.6V, f=1kHz, P _O =0.6W, R _L =8Ω		90		%
V _{IH}	CTRL input high level	enable	1.2		V _{DD}	V
V _{IL}	CTRL input low level	turn off	0		0.2	V
T _{st}	Start up time	Switch from the turn off state to the Enable state		120		ms
T _{sd}	Turn off time	Switch from the Enable state to the turn off state	80			ms

8 Typical characteristic curves

In the following characteristic curves, $T=25^{\circ}\text{C}$, unless conditions are specified.

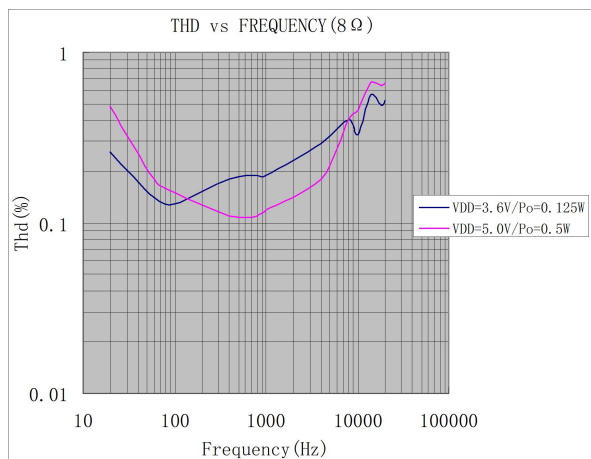
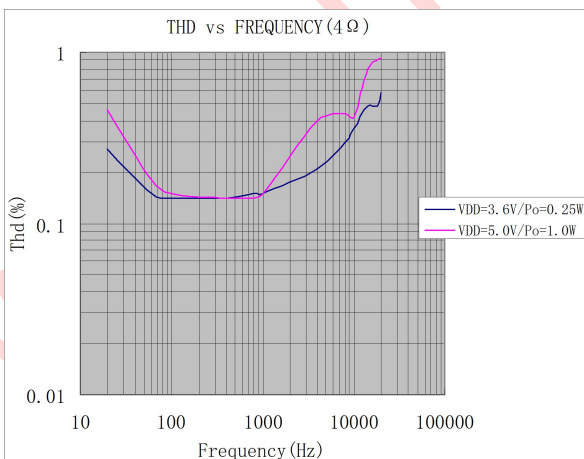
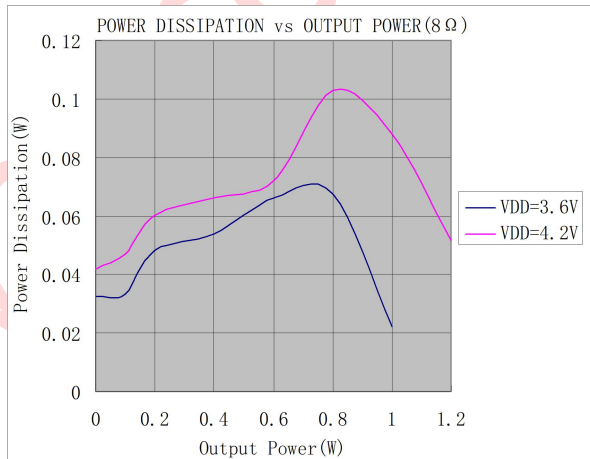
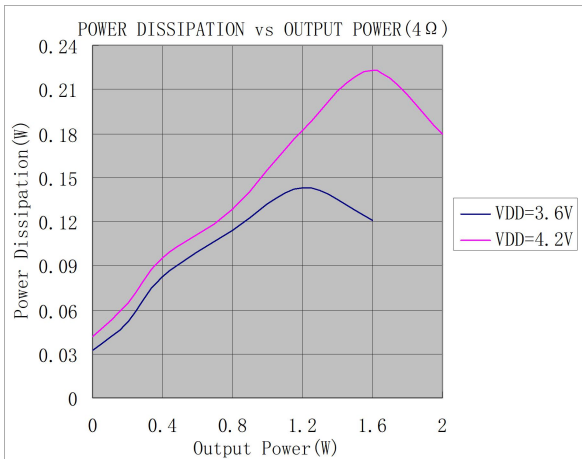
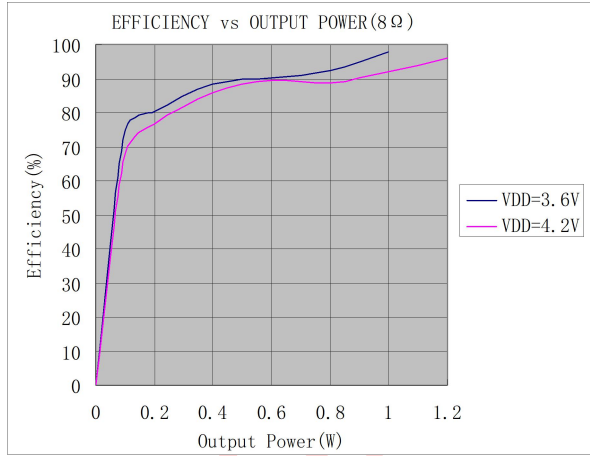
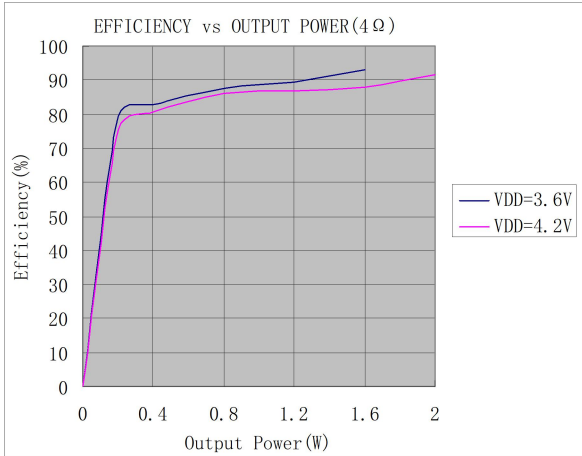

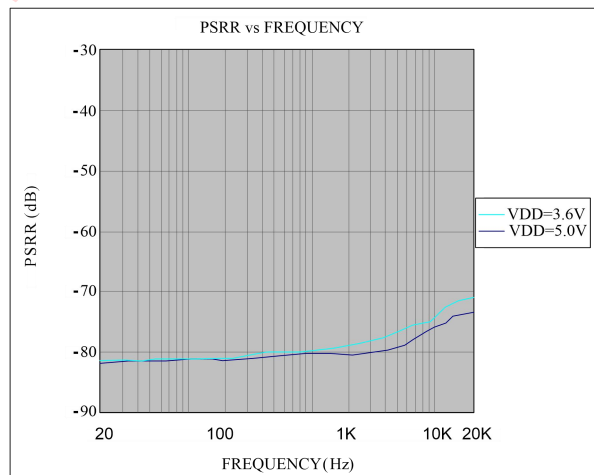
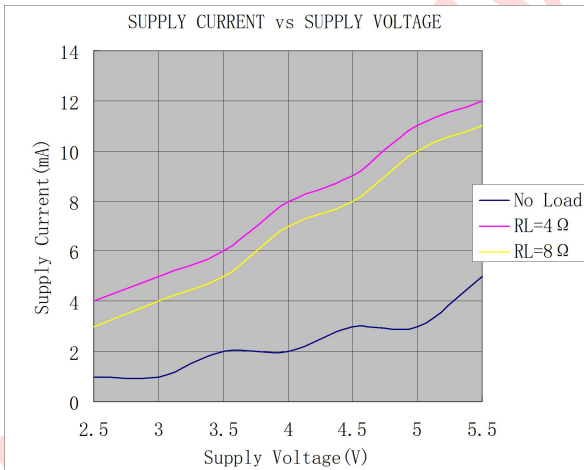
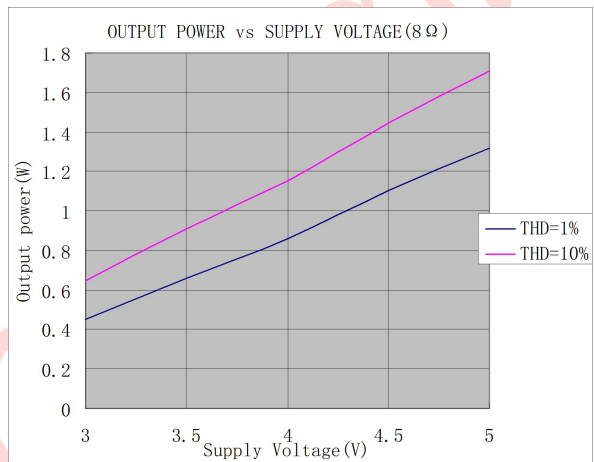
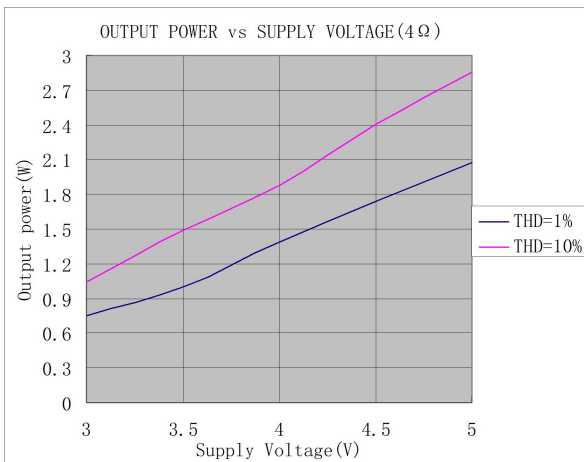
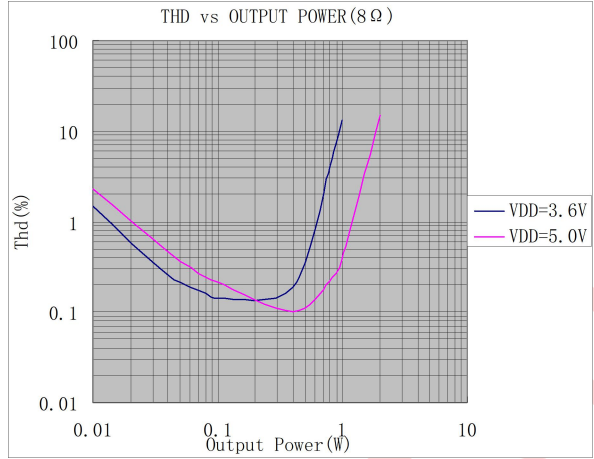
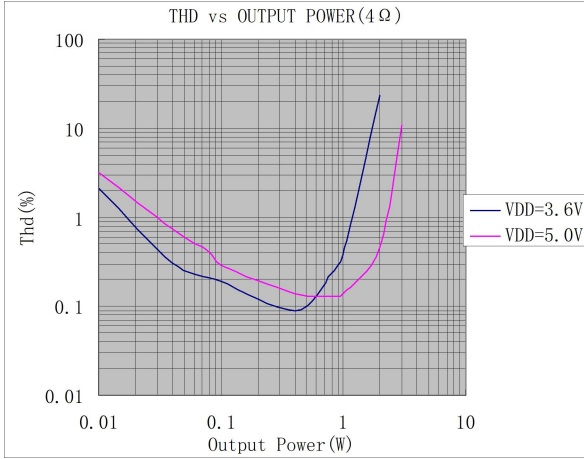

9 Application specification

9.1 Basic structure description

NS4150B is an ultra-low EMI, filterless 3W mono Class D audio power amplifier. At 5V power supply, it can provide 3W power to a 4Ω load with up to 90% efficiency. NS4150B uses advanced technology to greatly reduce EMI interference in the full bandwidth range, minimizing the impact on other components.

The NS4150B's filterless PWM modulation structure and gain built-in mode reduce the number of external components, PCB area and system cost. Using spread spectrum technology to fully optimize the new circuit design. The chip has built-in functions of overcurrent protection, overheat protection and undervoltage protection, which can turn off the chip under abnormal working conditions to effectively protect the chip from being damaged. When the abnormal conditions are eliminated, NS4150B automatically restores to work. Its principle block diagram is as follows:

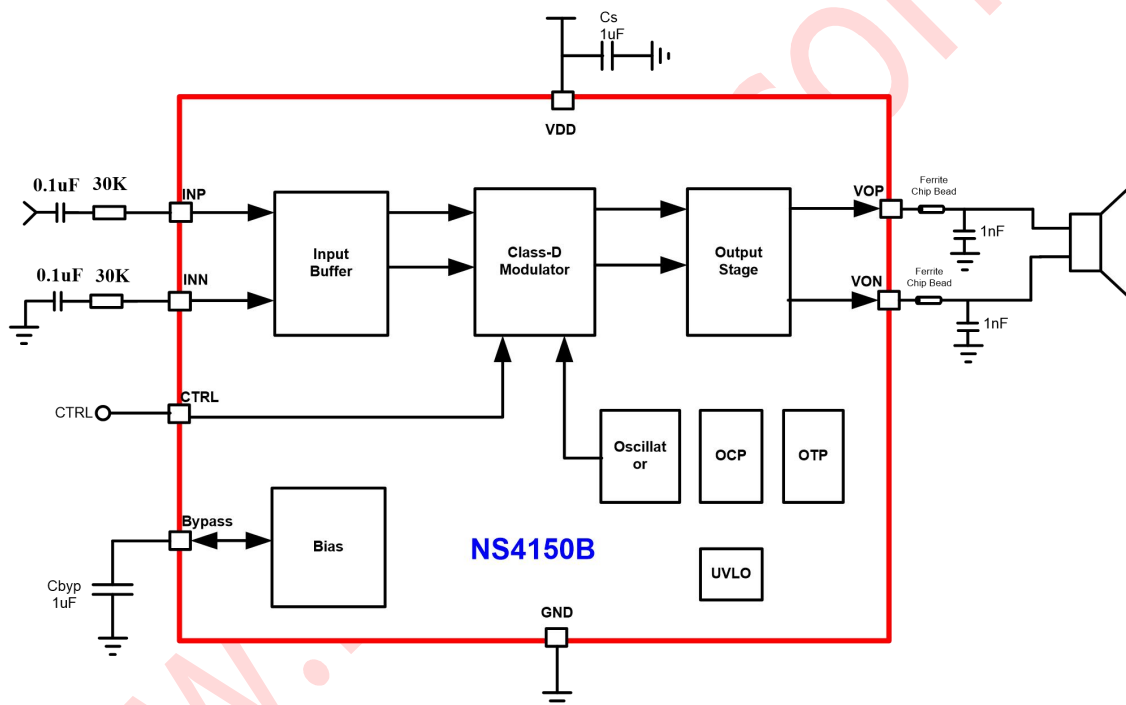

9.2 Filterless output

NS4150B adopts filterless PWM modulation mode, which eliminates LC filter of traditional Class D amplifier, improves efficiency and provides a smaller area and lower cost solution.

9.3 Power on and power off noise suppression

NS4150B has built-in power-on and power-off noise suppression circuit, effectively eliminate the system in power-on, power-off, wake up and shut down operations may appear transient noise.

9.4 EMI enhancement technology

NS4150B has built-in EMI enhancement technology. With using advanced technology, EMI interference is greatly reduced in the full bandwidth range, minimizing the impact on other components. As shown in the

figure:

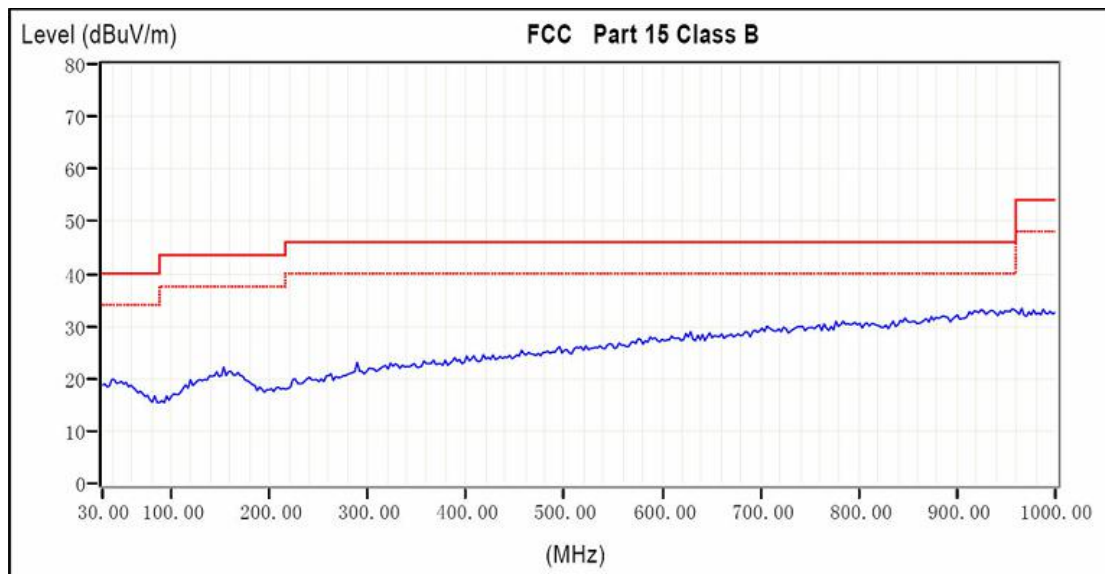

9.5 CTRL pin setting

The operating mode of NS4150B can be set by setting the level value of CTRL pin, as shown in the table:

CTRL	Mode
H	Open
L	Shutdown

9.6 Efficiency

The NS4150B utilizes extended spectrum technology to fully optimize the circuit design of the new Class D amplifier to improve efficiency. Up to 88% efficiency is more suitable for portable audio products.

9.7 Protect circuit

In the event of a short circuit between the output pins, the overcurrent protection circuit shuts off the chip to prevent damage. After the short-circuit fault is removed, the NS4150B automatically recovers. When the temperature of the chip is too high, the chip is also turned off. After the temperature drops, NS4150B continues to work normally. When the power supply voltage is too low, the chip will also be turned off. After the power supply voltage is restored, the chip will start again.

9.8 Power supply decoupling capacitor

An appropriate decoupling capacitor at the power supply end can ensure high efficiency and the best THD+N performance of the device. Meanwhile, in order to obtain good high frequency transient performance, it is expected that the ESR value of the capacitor should be as small as possible. A ceramic capacitor of 1uF is generally used to bypass the V_{DD} to ground. The decoupling capacitor should be laid out as close as possible to the V_{DD} of the chip. If you want to filter low frequency noise better, you need to add a decoupling capacitor of 10uF or larger depending on the application.

9.9 Gain setting and input resistance

NS4150B internal integrated feedback resistance is 240K, gain $A_{VD} = \frac{240 K\Omega}{R_{in}}$, which R_{in} is the external input resistance.

9.10 Input filter

The audio signal is fed to the INP and INN of the NS4150B via a isolating capacitor and input resistor. The input capacitor C_{in} and the input resistor R_{in} form a high-pass filter. The cut off frequency is

$$f_c = \frac{1}{2\pi \cdot R_{in} \cdot C_{in}}$$

In fact, in many applications, the speaker cannot reproduce low frequency speech below 100HZ-150Hz, so using large capacitors does not improve system performance. In addition to considering the performance of the system, the suppression performance of on and off/switching noise is affected by capacitance. If the coupling capacitance is large, the delay of the feedback network is large, resulting in POP noise. Therefore, a small coupling capacitance can reduce the noise.

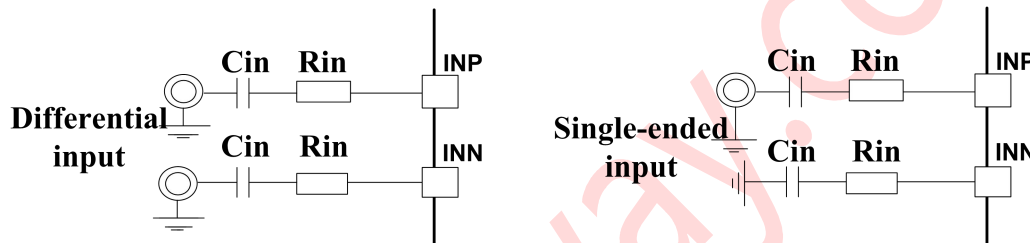

9.11 Magnetic beads and capacitances

NS4150B can still meet FCC standard requirements for 60cm audio cable without magnetic beads and capacitances. If the output audio cable is too long or the device layout is close to EMI sensitive devices, magnetic beads and capacitors are recommended. Magnetic beads and capacitors should be placed as close to the chip as possible.

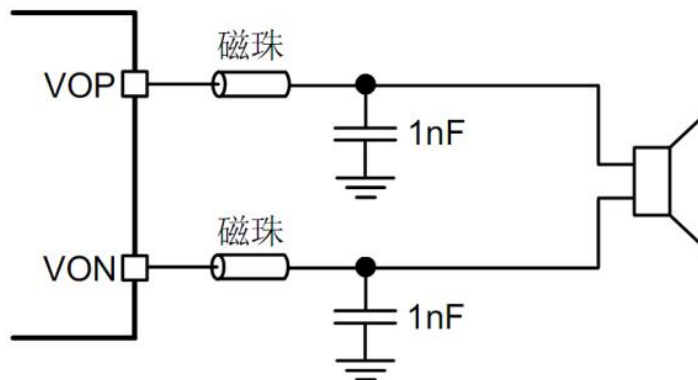

10 Packaging information

10.1 MSOP-8 package dimension drawing

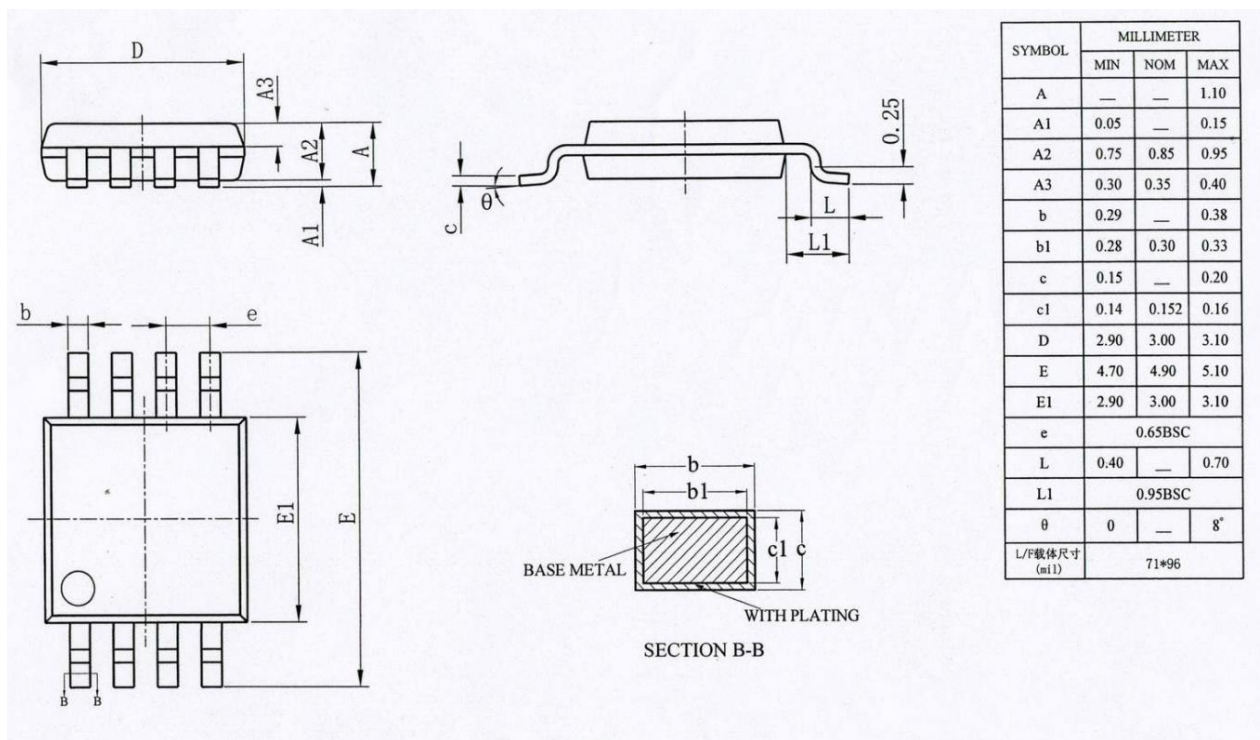

12 Version Change History

Notice : Shenzhen Nsiway Co. LTD. reserve the right to modify the datasheet at anytime without notice.Only Shenzhen Nsiway Co. LTD. have the right to explain the content in this datasheet.