



NS4158 Data Sheet V1.0

ShenZhen Nsiway Technology Co., Ltd

2012,10

General Description

NS4158 is a class D can switch work mode, with the function of preventing distortion, low EMI, no filter, 5 w high efficiency mono audio power amplifier. class D work mode can be controlled through a terminal high and low level switch, to match different application environment. Its unique prevent distortion function can effectively prevent the input signal overload, battery voltage drop caused by the output signal distortion, can effectively protect the power output at the same time the speaker is not damaged. The actual application can be set by software line pulse amplifier working in preventing distortion mode and normal mode. Even in class D work mode, NS4158 adopts advanced technology, within the scope of the whole bandwidth greatly reduces the EMI interference, minimize impact on the rest of the parts. The output PWM modulation structure without filter and feedback resistance built-in way to reduce the external components and PCB area and system cost. When the NS4158 working in voltage of 5 v, it can provide up to 4.5W for 2 Ω load output power.

NS4158 built-in over-current protection, overheating protection and under-voltage protection, effectively protect the chip under abnormal working conditions are not damaged. And using spread spectrum technology fully optimize a new circuit design, the efficiency of more than 85% is more suitable for low voltage, high power output audio system.

NS4158 provide SOP8 encapsulation, rated operating temperature range for - 40 $^{\circ}\text{C}$ to 85 $^{\circ}\text{C}$.

Features

- Prevent distortion function, a line of pulse Settings
- Output power. 2.8W(4 Ω load),4.5W(2 Ω load)
- Working voltage range: 3 V to 5.5 V
- 0.2%THD (1 W output power, 5 v power supply, 4 Ω load)
- 85% Efficiency
- Over-current, Thermal and Low voltage Malfunction Protection function
- Packages: SOP-8

Applications

- Blue speakers
- Loudspeaker
- Other portable audio

Typical Application Circuit

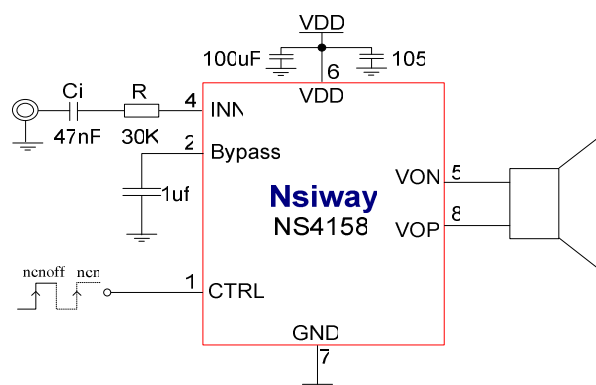

Figure1.NS4158 Typical Application Circuit

Absolute Maximum Ratings

Table1.Absolute Maximum Ratings

Parameter	Min	Max	Unit	Note
Supply Voltage VDD	2.8	5.5	V	
Junction Temperature		150	°C	
Storage Temperature	-65	150	°C	
Lead Temperature (Soldering 15 Seconds)		220	°C	
Package Thermal Resistance θ_{JA}		80	°C/W	
Operating Ambient Temperature	-40	85	°C	
ESD Rating		4000	V	Human Body Model

Note1: Stresses beyond those listed under "absolute maximum ratings" may cause permanent damage to the device. These are stress ratings only and functional operation of the device at these or any other conditions beyond those indicated under "recommended operating conditions" is not implied. Exposure to absolute-maximum-rated conditions for extended periods may affect device reliability.

Electrical Characteristics

Table2. Electrical Characteristics (TA=25oC)

Symbol	Parameter	Conditions	Min	Typ	Max	Units
V _{DD}	Output offset voltage	V _{IN} =0V, V _{DD} =3.0V to 5.5V		5	20	mV
I _{DD}	Quiescent Current	V _{DD} =3.6V, No load		8		mA
I _{SD}	Shutdown Current	V _{DD} =3.6V, CTRL=0V		1	10	μ A
PSRR	Power-Supply Rejection Ratio	217Hz			-80	dB
		20KHz			-72	dB
CMRR	Common-Mode Rejection Ratio			-70		dB
f _{SW}	Carrier clock frequency	V _{DD} =3.0V to 5.25V		400		kHz

P _O	Output power (NCNOFF)	THD=1%,ClassD f=1KHz,R _L =2 Ω		3.5		W
		THD=10%,ClassD f=1KHz,R _L =2 Ω		4.5		W
		THD=1%,ClassD f=1KHz,R _L =4 Ω		2.0		W
		THD=10%,ClassD f=1KHz,R _L =4 Ω		2.8		W
THD	Harmonic Distortion	V _{DD} =5V, P _O =1W, R _L =4Ω, f=1kHz		0.2		%
η	Efficiency	P _O =2W, R _L =4Ω, V _{DD} =5V, f=1kHz		85		%
V _{IH}	CTRL High voltage		1.8		V _{DD}	V
V _{IL}	CTRL Low voltage		0		0.2	V
T _{HI}	CTRL Pulse time(high or low)		1		12	us
T _{OFF}	CTRL Turn_off time		100			us
t _{AT}	Attack time	V _{DD} =3.6V, NCN		10		ms
t _{RL}	Release time	V _{DD} =3.6V, NCN		1.1		s
AMAX	Maximum attenuation gain			-10		dB

Pin Configuration

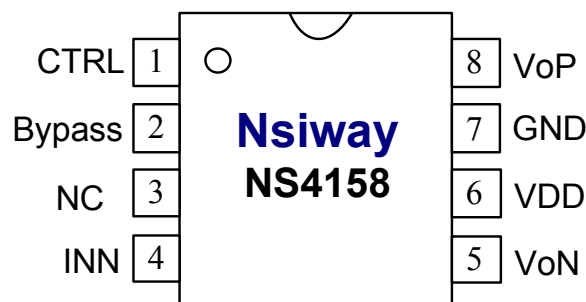

Figure2. SOP-8 (top view)

Pin Discription

Table3. Pin Discription

Pin NO.	Pin Name	Description
1	CTRL	Power down control terminal
2	Bypass	Analog reference power supply terminal
3	NC	No connecting
4	INN	Signal input
5	VoN	Negative output terminal (differential -)
6	VDD	Power supply
7	GND	Ground
8	VoP	Positive output terminal (differential +)

Typical Characteristics

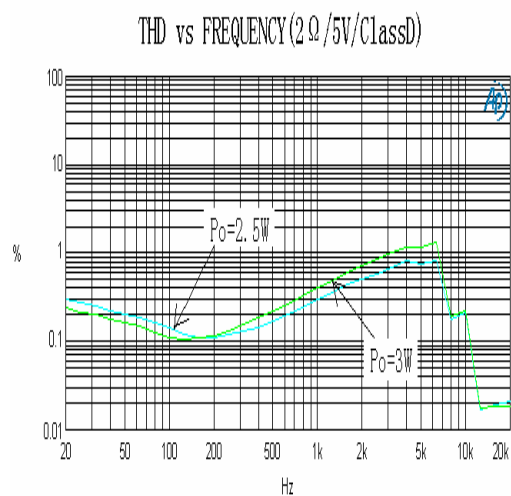
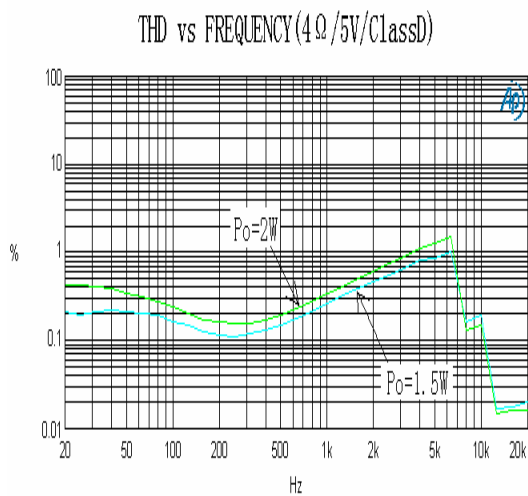
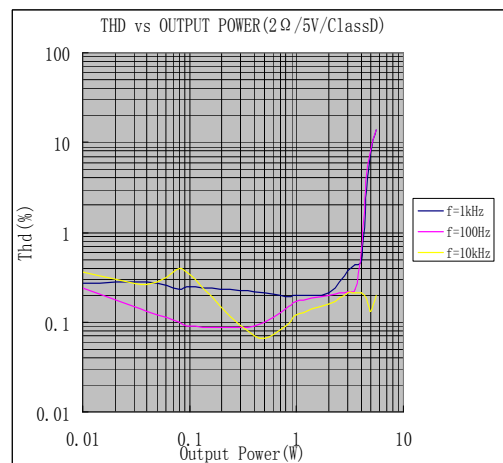
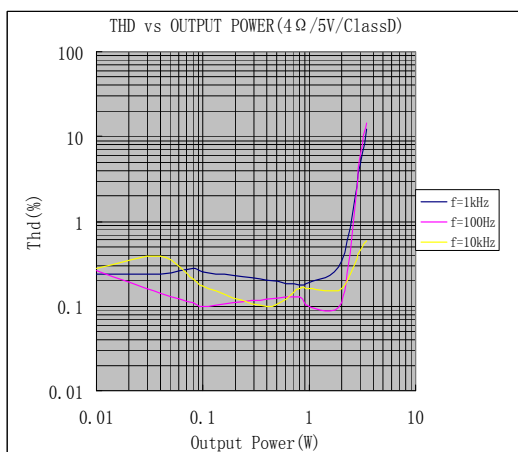
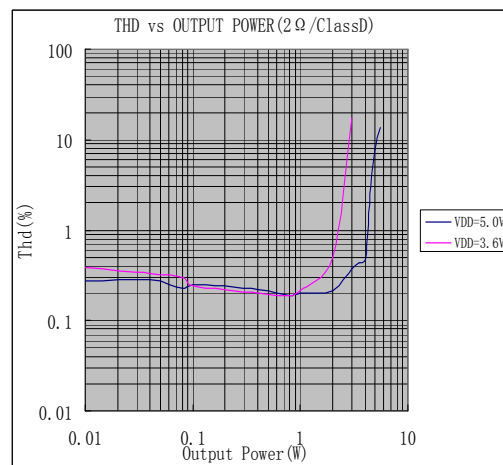
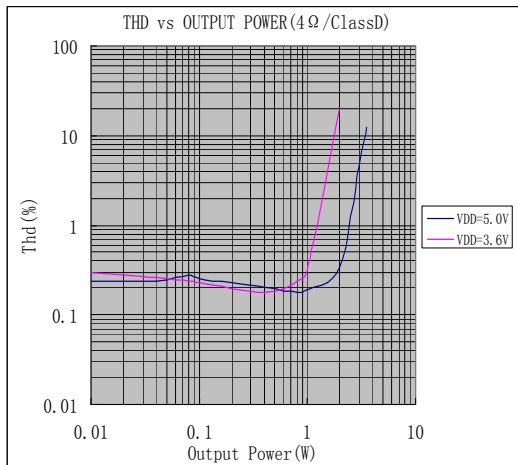

THD vs FREQUENCY (4Ω /1W/ClassD)

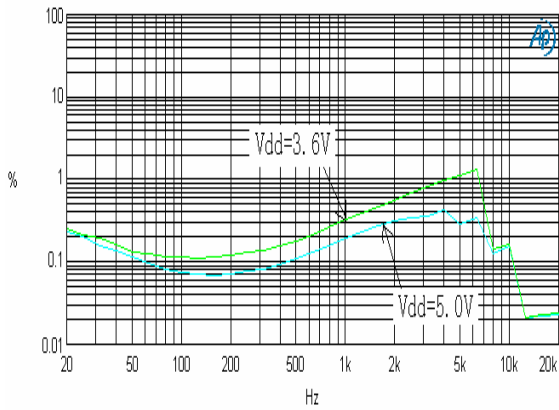

THD vs FREQUENCY (2Ω /2W/ClassD)

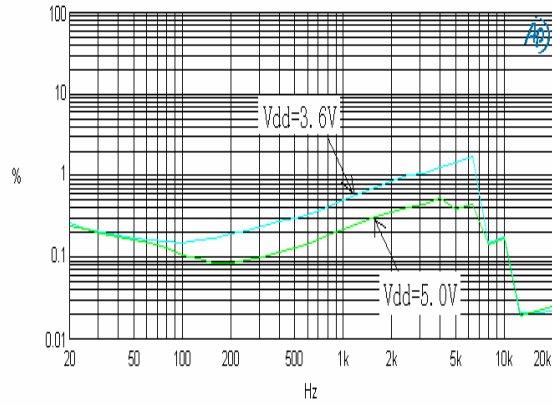

FREQUENCY vs RESPONSE (Vdd=5V/ClassD)

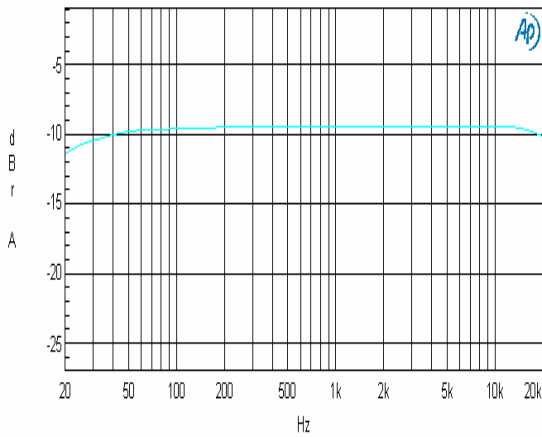

POWER SUPPLY RITPLE REJECTION vs FREQUENCY (Vdd=5V/ClassD)

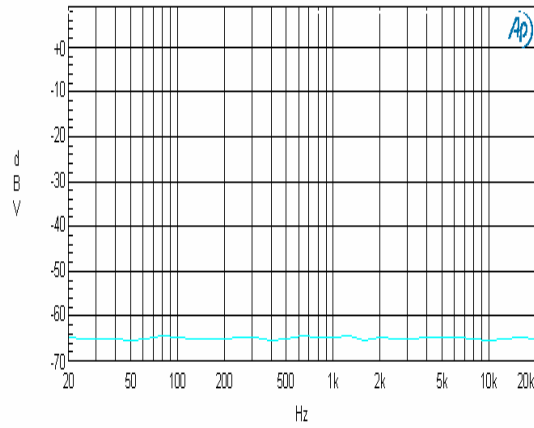

FFT of Noise Output (Vdd=5V/Class D)

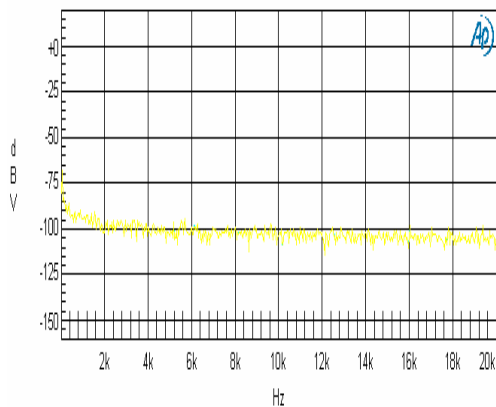

EFFICIENCY vs OUTPUT POWER (4Ω)

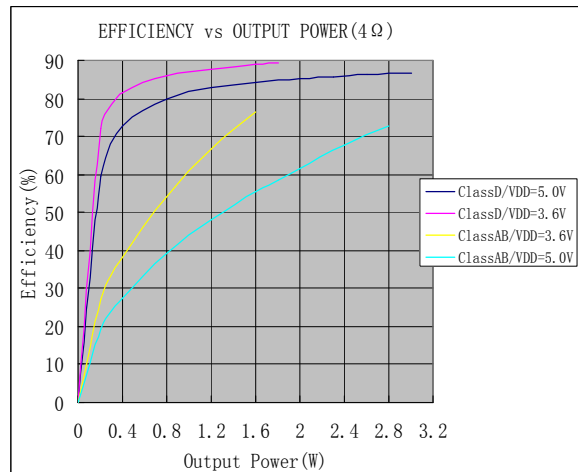

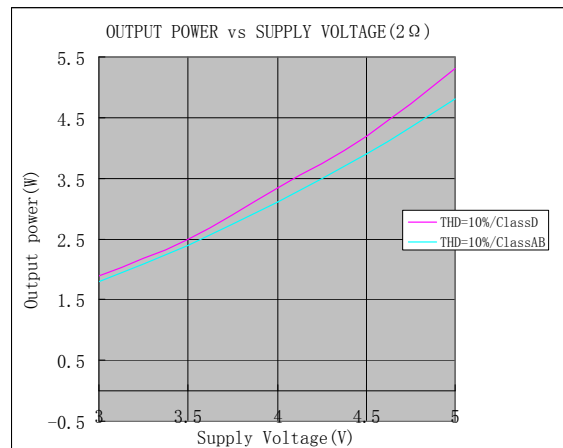
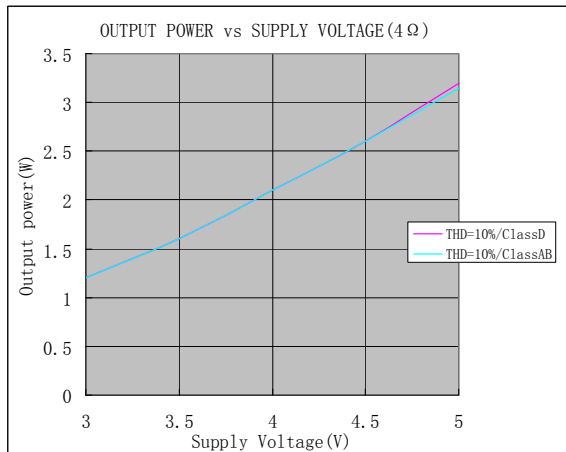

Application Information

Block Diagram

NS4158 is a class D can be realized working mode switching, with the function of preventing distortion (NCN), low EMI, no filter, mono audio power amplifier. Chip internal integration the feedback resistance, amplifier gain can be set in the periphery through input resistance, and bridge output. The principle block diagram is as follows:

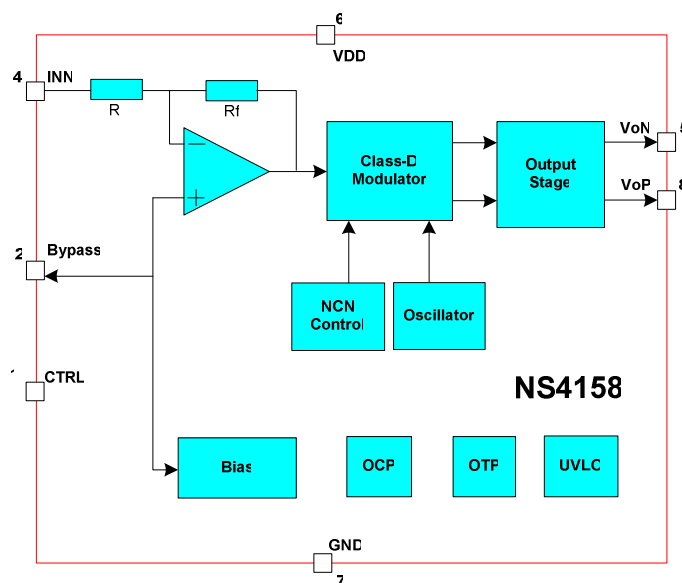

Figure3.The block diagram of NS4158

NS4158 application instructions

NS4158 is a class D can be realized working mode switching, with the function of preventing distortion (NCN), low EMI, no filter, mono audio power amplifier. Chip internal integration the feedback resistance, amplifier gain can be set in the periphery through input resistance, and bridge output. The principle block diagram is as follows:

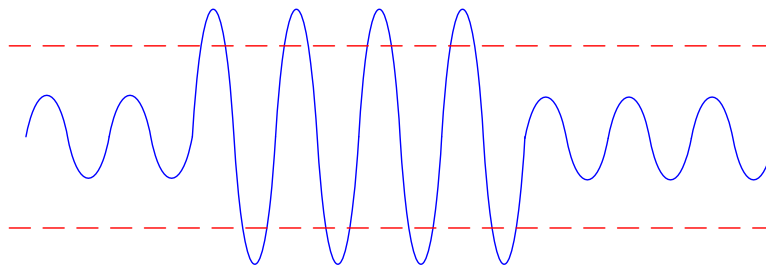

Figure 4. Assumptions without being limited by the power supply voltage of the audio output signal

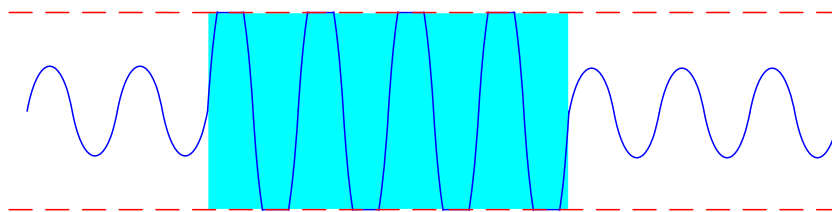

Figure 5. Normal working mode of the audio output signal

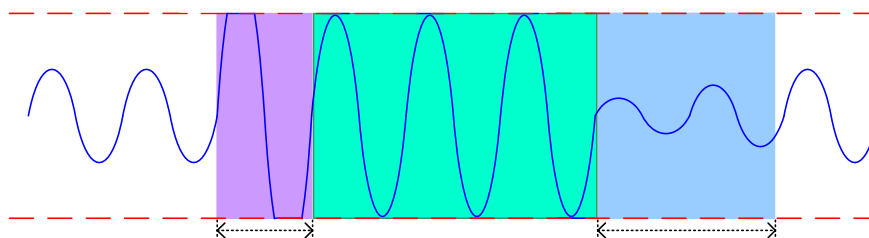

Figure 6. Audio output signal distortion prevention work mode

Application parameters

distortion function on and off

NS4158 support line pulse through the CTRL pin control NS4158 prevent distortion (NCN) function is on. CTRL pin a rising edge is detected, the chip working in normal mode (NCNOFF); Along the CTRL pin detection of two consecutive rise, chip work in preventing distortion mode (SAP). CTRL pin more than 100 uS down and keep the chip into SHUTDOWN (SHUTDOWN) mode. After chip into SHUTDOWN (SHUTDOWN) mode. If you want to re-enter the two modes of one of the must be reset. Schematic diagram is as follows:

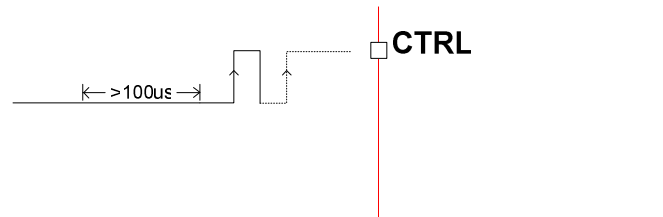

Figure 7: the distortion (NCN) feature set

In addition, the distortion (NCN) model can only work in the Class D status, the Class AB condition, even if the CTRL pin along the detected two consecutive rise, work mode with CTRL pin detects a rising along the same. Class AB condition without distortion (NCN) function. About the Class AB and the Class D state see below.

Plus a line in the CTRL pin high level pulse width (THI) requires $1\ \mu\text{s} < \text{THI} < 12\ \mu\text{s}$. Low level width (TLO) requires $1\ \mu\text{s} < \text{TLO} < 12\ \mu\text{s}$. Into SHUTDOWN mode in a low level (TOFF) require $\text{TOFF} > 100\ \mu\text{s}$. Sequence diagram is as follows:

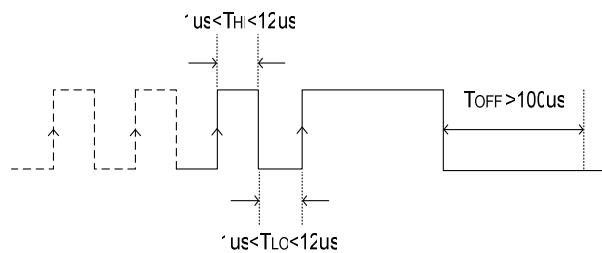

Figure 8. A line of pulse sequence diagram

gain calculation

NS4158 gain through an external input resistance Ri Settings.

Distortion function closure (NCNOFF), gain calculation formula is: $A_v/R_i = 360 \text{ k}$, 360 k for chip internal feedback resistance value. If the input resistance $R_i = 40 \text{ k}$, the gain is: $A_v = 360 \text{ k} / 40 \text{ k} = 9$ times (19 db).

The choice of input capacitance Ci

Input capacitance and input resistance constitutes a high-pass filter, frequency of $f_c = 1 / (2 * R_i * \pi C_i)$. Too much input capacitance, increase the cost, increase area, this for cost, area of the application of tension, very bad. Obviously, determine how much capacitance are used to complete the coupling is very important. In fact, in many applications, the Speaker (Speaker) will not be able to reproduce the below 100 hz - 150 hz low frequency voice, so the large capacitance is not able to improve the performance of the system. In addition to consider the performance of the system, the switch/switching noise suppression performance is affected by capacitance, if coupling capacitance is large, the feedback network delay is large, lead to pop noise appear, therefore, the small coupling capacitance can reduce the noise. If the input resistance $R_i = 10 \text{ k}$, it was decided that take $f_c = 150 \text{ hz}$ frequency, input capacitance $C_i = 1 / (2 * R_i * \pi f_c) = 0.1 \text{ uF}$.

bypass capacitors Cb choice

The stability of the Cb decided NS4158 static working point, so when open a burst of input signal is critical to its value. The Cb, the greater the chip output tilt to the static dc voltage ($V_{DD} / 2$) slower, the smaller the crackle of the open. Cb 1 uf can get a "tick" and "crackling" smaller shut off function.

the power filter capacitor

In the application of the amplifier, the power of the bypass design is very important, especially for the noise performance of a application solutions and supply voltage suppression performance. Requirements in the design of the filter capacitor close to the chip power. Typical capacitance for 100 uf capacitance and 1 uf ceramic capacitors.

the efficiency

NS4158 using spread spectrum technology to fully optimize new digital amplifier circuit design, in order to improve efficiency. Up to more than 85% of the efficiency is more suitable for low voltage high power

output.capacity.

protection circuit

When chip and power supply output pin or short circuit, or between the output short circuit fault, over-current protection circuit will shut off chip in order to prevent the chip is damaged. After fault elimination, NS4158 automatically return to work. When the temperature of the chip is too high, the chip will be shut off. Temperature drop after NS4158 continue to work normally. When the supply voltage is too low, the chip will also be shut off, the power supply voltage after recovery, the chip will start again.

Layout proposal

Class D NS4158 work mode, the EMI interference should be considered. The application from the following several aspects can minimize EMI interference:

1. Linear power amplifier output to the speaker, attachment as far as possible short, wide, as far as possible and output wiring, cords as far as possible away from sensitive signal lines and circuits.
2. The decoupling capacitor amplifier power feet as close to the chip pins. The power cord, ground had better use y connection.
3. The reason of limited because of the space application when the environment is bad on the output side with magnetic beads and capacitance can effectively restrain EMI interference. When using magnetic beads and capacitor as close to the chip pins. Here are NS4158 output terminal and the application design of magnetic beads and capacitor after reference circuit:

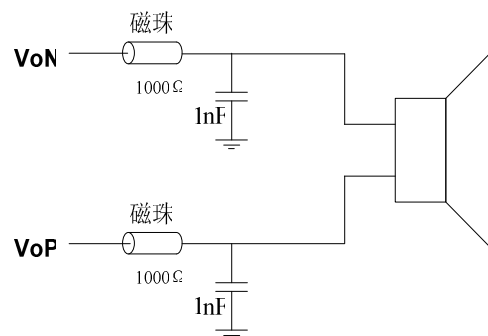

Figure 10. Output figure applied magnetic beads

Test circuit

NS4158 test circuit diagram, measurement mode of class D power amplifier, Low PASS Filter (Low PASS Filter) is a must. Can use two 33 uH on both ends of the load resistance in the equivalent inductance in series speakers. If only use pure resistance to replace the speaker load, the test results will be worse than speakers do load results, including power, efficiency, distortion and so on.

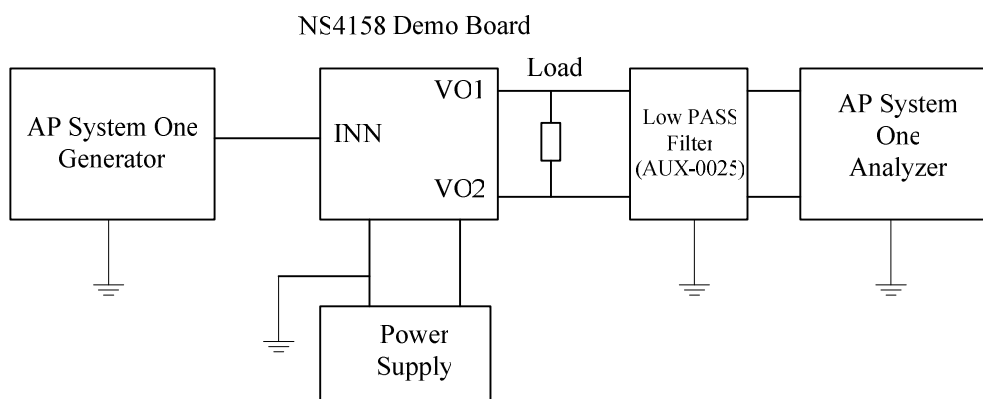
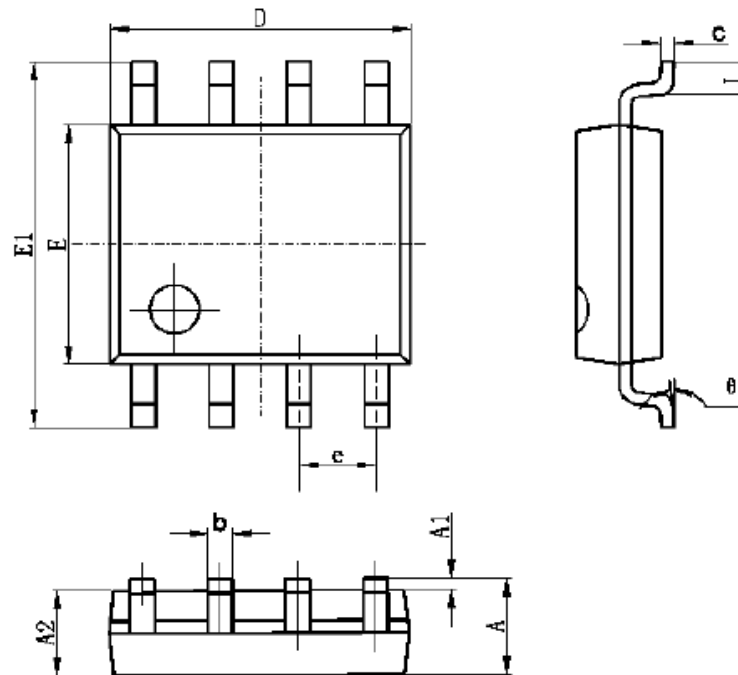

Figure 11. NS4158 test circuit

The Package of SOP-8

Symbol	Dimensions In Millimeters		Dimensions In Inches	
	Min	Max	Min	Max
A	1.350	1.750	0.053	0.069
A1	0.100	0.250	0.004	0.010
A2	1.350	1.550	0.053	0.061
b	0.330	0.510	0.013	0.020
c	0.170	0.250	0.006	0.010
D	4.700	5.100	0.185	0.200
E	3.800	4.000	0.150	0.157
E1	5.800	6.200	0.228	0.244
e	1.270 (BSC)		0.050 (BSC)	
L	0.400	1.270	0.016	0.050
θ	0°	8°	0°	8°

Figure 12. The SOP - 8 packaging size figure

Notice: Shenzhen Nsiway Co. LTD. Reserve the right to modify the datasheet at anytime, And without notice, Only Shenzhen Nsiway Co. LTD. have the right to explain the content in this datasheet.