

NSE-5310

Miniature Position Encoder with Zero Reference and I²C Output

1 General Description

The TRACKER NSE-5310 is an incremental position sensor with on-chip encoding for direct digital output. A Hall element array on the chip is used to derive the incremental position of an external magnetic strip placed above the IC at a distance of 0.3 mm (typ). This sensor array detects the ends of the magnetic strip to provide a zero reference point.

The integration of Hall-effect position sensors, analog front end and digital signal processing on a single IC chip provides an ingeniously small position sensor, without the need for external pulse counters. Direct digital output is accessible over the serial interface using I²C protocol.

The TRACKER NSE-5310 provides absolute position information over the length of a magnet pole pair (2 mm). A user can count pole pairs and achieve absolute position information over the entire length of the magnet (essentially unlimited).

With better than 0.5 micron resolution, the TRACKER is a robust, cost-effective alternative to miniature optical encoders. It can be used as a linear or off-axis rotary encoder.

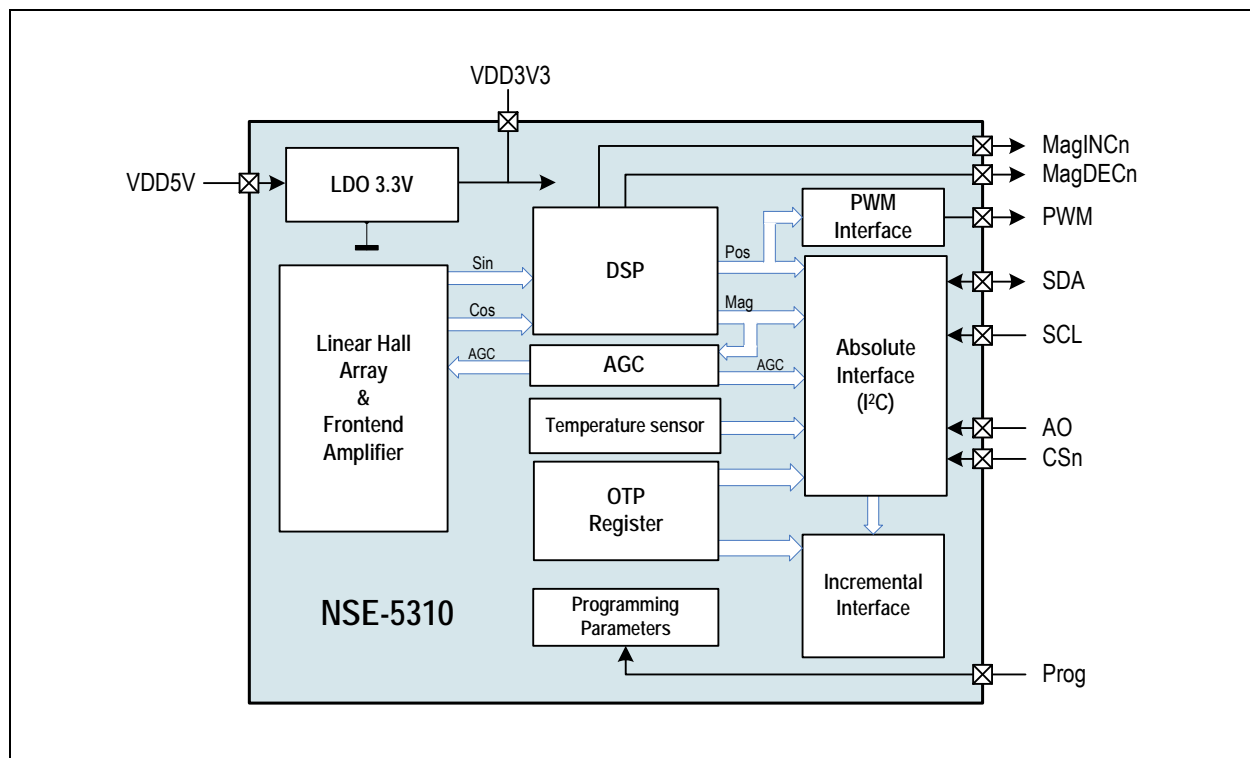
2 Key Features

- Direct digital output using I²C protocol
- End-of-magnet detection for built-in zero reference
- 0.488 μm resolution
- < 2 μm bi-directional repeatability
- < ±10 μm absolute error
- On-chip temperature sensor
- Magnetic field strength monitor
- Available in TSSOP-20
- Custom packaging such as wafer-level chip scale packaging can be provided. Minimum order quantities may apply.
- RoHS compliant

3 Applications

The NSE-5310 is ideal for Micro-actuator and servo drive feedback, Replacement for optical encoders, Optical and imaging systems, Consumer electronics, Precision biomedical devices, Instrumentation and automation, Automotive applications, and Integrated closed-loop motion systems using New Scale's SQUIGGLE micro motor.

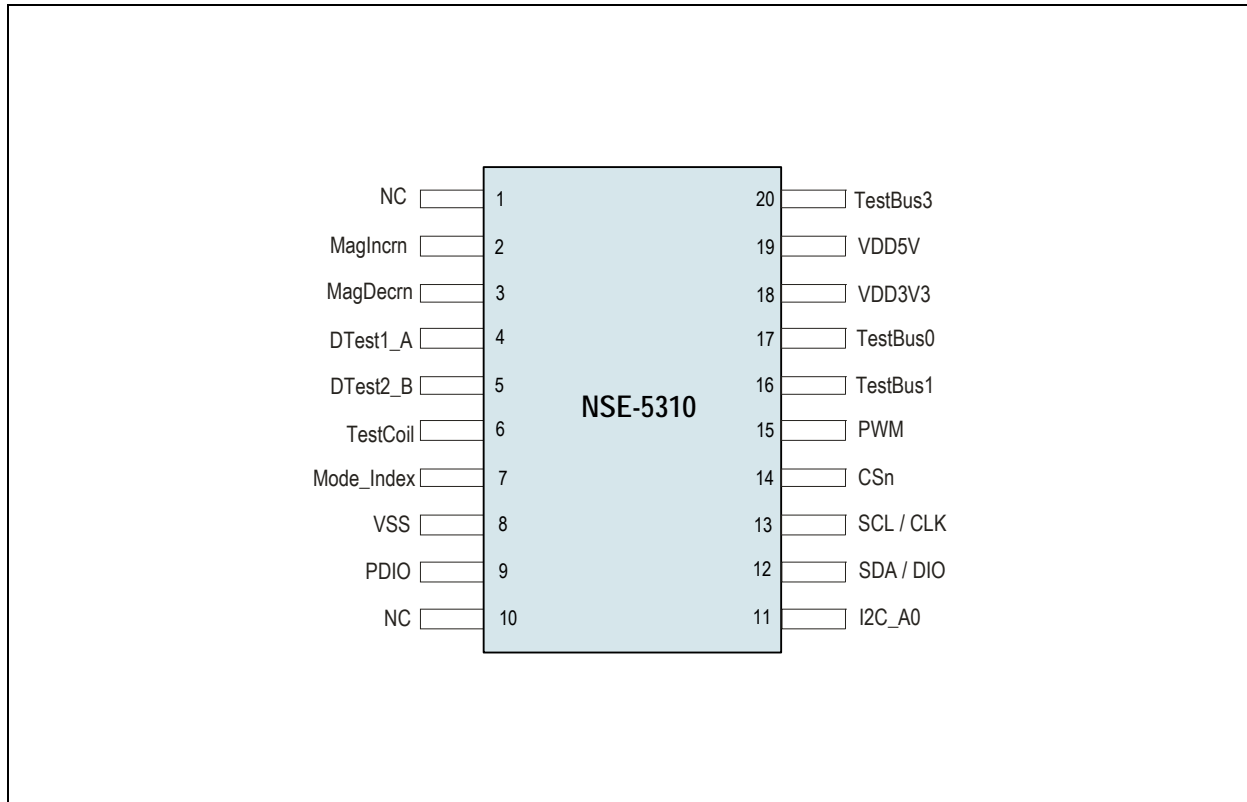
Figure 1. TRACKER NSE-5310 Block Diagram





4 Pin Assignments

Figure 2. Pin Assignments (Top View)



4.1 Pin Descriptions

Table 1. Pin Descriptions

Pin Number	Pin Name	Pin Type	Description
1	NC		Not Connected
2	MagINCn	Digital output open drain	Indicates increasing or decreasing of magnitude by the AGC. Can be used for Push Button Function. Both signals are active low if AGC is in Non Valid Range and can be hooked together in wired-AND Non Valid X / Y Alignment during Align Mode
3	MagDECn		
4	DTEST1_A		
5	DTEST2_B		
6	Coil	Analog I/O	Serial connection of Hall Element Coils to VSS
7	Mode_Index	Digital I/O with pull-down Digital output open drain	Decimation Rate Selection internal pull down, by default DCR = 256. Static setup at power up.
8	VSS	Supply pad	Ground
9	PDIO	Digital I/O Analog I/O	Digital and Analog Access to PPTRIM
10	NC		Not connected
11	I2C A0	Digital input with pull-down	Digital input to choose I ² C address by input pin. This pin is the I ² C address pin (0 or 1) to select the position sensor when two sensors are used.



Table 1. Pin Descriptions

Pin Number	Pin Name	Pin Type	Description
12	SDA (DO)	Digital I/O / Tristate	DATA Input / Output for I²C Mode. This pin is the I2C serial interface used to read direct position information. This pin can also be used to read the absolute magnitude of the magnetic field (used to detect the end of the magnet, as a zero reference), and the temperature sensor information. See I²C User Interface on page 12 for more information.
13	SCL (CLK)	Digital input	Serial Interface Unit CLK, also used for PPTIM access. Frequency up to 400 KHz.
14	CSn	Digital input with pull-up	ChipSelect / DO tristate / Reset Device in TestEN Mode / Control Mode at PPTIM access
15	PWM	Digital output	~200 Hz Pulse Width Modulation Absolute Output
16	TestBus1	Analog I/O	Analog Test Bus1 / Configurable IO
17	TestBus0		Analog Test Bus0 / Configurable IO
18	VDD3V3	Supply pad	LDO Output. Positive I/O supply voltage pin. See Using 3.3V or 5V Operation on page 10 for more information.
19	VDD5V		LDO Input / Connection to IO structure. Positive I/O supply voltage pin. See Using 3.3V or 5V Operation on page 10 for more information.
20	TestBus3	Analog I/O	Analog Test Bus3 / Configurable IO



5 Absolute Maximum Ratings

Stresses beyond those listed in [Table 2](#) may cause permanent damage to the device. These are stress ratings only, and functional operation of the device at these or any other conditions beyond those indicated in [Electrical Characteristics on page 5](#) is not implied. Exposure to absolute maximum rating conditions for extended periods may affect device reliability.

Table 2. Absolute Maximum Ratings

Symbol	Parameter	Min	Max	Units	Comments
V _{IN} VDD5V	DC Supply Voltage at pin VDD5V	-0.3	7	V	
V _{IN} VDD3V3	DC Supply Voltage at pin VDD3V3		5	V	
VDD	DC Supply Voltage		7	V	Except VDD3V3
V _{IN}	Input Pin Voltage		VDD+ 0.3	V	
V _{IN} VDD3V3	Input Pin Voltage VDD3V3		5	V	
I _{scr}	Input Current (latchup immunity)	-100	100	mA	Norm: Jedec 78
ESD	Electrostatic Discharge		±2	kV	Norm: MIL 883 E method 3015
T _{strg}	Storage Temperature (TSSOP)	-55	125	°C	
T _{body}	Body temperature (Lead-free package)		260	°C	Norm: IPC/JEDEC J-STD-020. The reflow peak soldering temperature (body temperature) specified is in accordance with IPC/JEDEC J-STD-020C "Moisture/Reflow Sensitivity Classification for Non-Hermetic Solid State Surface Mount Devices".
	Humidity non-condensing	5	85	%	
R _{th}	Thermal Package Resistance		114.5	°C/W	
MSL	Moisture Sensitivity Level		3		Represents a maximum floor time of 168h



6 Electrical Characteristics

Table 3. Operating Conditions

Symbol	Parameter	Conditions	Min	Typ	Max	Units
VDD5V	Positive I/O Supply Voltage	5V Operation via LDO	4.5	5.0	5.5	V
VDD3V3		IO structure on VDD5V connected to VDD3V3	3	3.3	3.6	V
VDDD/ VDDA	Positive Core Supply Voltage	5V Operation over LDO Internal analog and digital supply	3	3.3	3.6	V
TAMB	Ambient Temperature	-40°F to +275°F	-40		125	°C
I _{supp}	Supply Current			16	21	mA

6.1 Magnet Input Specification

Table 4. Two Pole Cylindrical Diametrically Magnetized Source

Symbol	Parameter	Conditions	Min	Typ	Max	Units
pL	Pole Length			1		mm
ppL	Pole Pair Length	Magnetic North & South Pole		2		mm
pLV	Pole Length Variation	% of ppL 2mm			±1.2	%
B _{pk}	Magnetic input field amplitude	Required vertical component of the magnetic field strength on the die's surface	10		40	mT
B _{pkV}	Magnetic input field variation	Amplitude variation over encoder length			±2	%
B _{tc}	Magnetic Field Temperature Drift	Samarium Cobalt ReComa28 typ - 0.035 %/K			-0.2	%/K
B _{off}	Magnetic offset	Constant magnetic stray field			±5	mT
V _{abs}	Linear travelling speed	Absolute output	see note below			

Note: There is no upper speed limit for the absolute outputs. With increasing speed, the distance between two samples increases. The travelling distance between two subsequent samples can be calculated as:

$$\text{sampling_dist} = \frac{v}{f_s}$$

where:

sampling_distance = travelling distance between samples in mm

v = travelling speed in mm/sec

f_s = sampling rate in Hz

Pole crossings need to be tracked to calculate absolute position beyond one pole pair. The ability to differentiate pole crossings may be a speed limiting factor in such cases.



6.2 Electrical System Specifications

Table 5. Electrical System Specifications

Symbol	Parameter	Conditions	Min	Typ	Max	Units
RES	Resolution	0.48828125 μm (max. 2mm/4096)			12	bit
INL _{opt}	Integral non-linearity (optimum)	Maximum error with respect to the best line fit. Ideal magnet, T _{AMB} =25°C			± 5.6	μm
INL _{temp}	Integral non-linearity (over temperature)	Maximum error with respect to the best line fit. Ideal magnet, T _{AMB} = -30 to +70°C			± 10	μm
INL	Integral non-linearity ¹	Best line fit = (Err _{max} - Err _{min})/2 including magnet error, T _{AMB} = -30 to +70°C			± 40	μm
DNL	Differential non-linearity	10bit, no missing codes			± 0.97	μm
TN	Transition noise	1 sigma, fast mode			0.6	$\mu\text{m RMS}$
		1 sigma, slow mode			0.3	
t _{PwrUp}	Power-up time	Fast mode until status bit OCF=1			20	ms
		Slow mode			80	
t _{delay}	System propagation delay	Fast mode (MODE=1)			96	μs
		Slow mode (MODE=0 or open)			384	
f _s	Internal sampling rate for absolute output:	T _{AMB} =25°C, slow mode	2.48	2.61	2.74	kHz
		T _{AMB} = -30 to +70°C, slow mode	2.35	2.61	2.87	
		T _{AMB} =25°C, fast mode	9.90	10.42	10.94	
		T _{AMB} = -30 to +70°C, fast mode	9.38	10.42	11.46	
Hyst	Hysteresis	Incremental output /12bit resolution Hyst=0 for absolute serial output	2		8	LSB
t _{PwrUp}	Power Up Time	Mode dependant	20		80	ms
CLK	I ² C Read-out frequency	Maximum clock frequency to read out serial data		400	800	kHz

1. System integral non linearity is limited by magnetic source.



6.3 DC/AC Characteristics for Digital Inputs and Outputs

Table 6. CMOS Input, CMOS Input Pull Down, CMOS Input Pull Up

Symbol	Parameter	Conditions	Min	Typ	Max	Units
V_{IH}	High Level Input Voltage	Operating range VDD5V	1.6		0.4	V
V_{IL3V3}	Low Level Input Voltage					
V_{IH}	High Level Input Voltage	Operating range VDD3V3	1.3		0.4	V
V_{IL3V3}	Low Level Input Voltage					
I_{LEAK}	Input Leakage Current CMOS Input		-1		+1	μA
$I_{LEAKLOW}$	Input Leakage Current CMOS Input Pull up		-30		-100	μA
$I_{LEAKHIGH}$	Input Leakage Current CMOS Input Pull down		30		100	μA

Table 7. CMOS Output

Symbol	Parameter	Conditions	Min	Typ	Max	Units
V_{OH}	High Level Output Voltage	DVDD: Positive I/O Supply Voltage	DVDD -0.5			V
V_{OL}	Low Level Output Voltage	DVSS: Negative Supply Voltage			DVSS +0.4	V
CL	Capacitive Load				50	pF
I_o	Output Current				4	mA

Table 8. Tristate CMOS Output

Symbol	Parameter	Conditions	Min	Typ	Max	Units
V_{OH}	High Level Output Voltage	DVDD: Positive I/O Supply Voltage	DVDD -0.5			V
V_{OL}	Low Level Output Voltage	DVSS: Negative Supply Voltage			DVSS +0.4	V
I_{oz}	Tristate Leakage Current	to DVDD and DVSS			1	μA

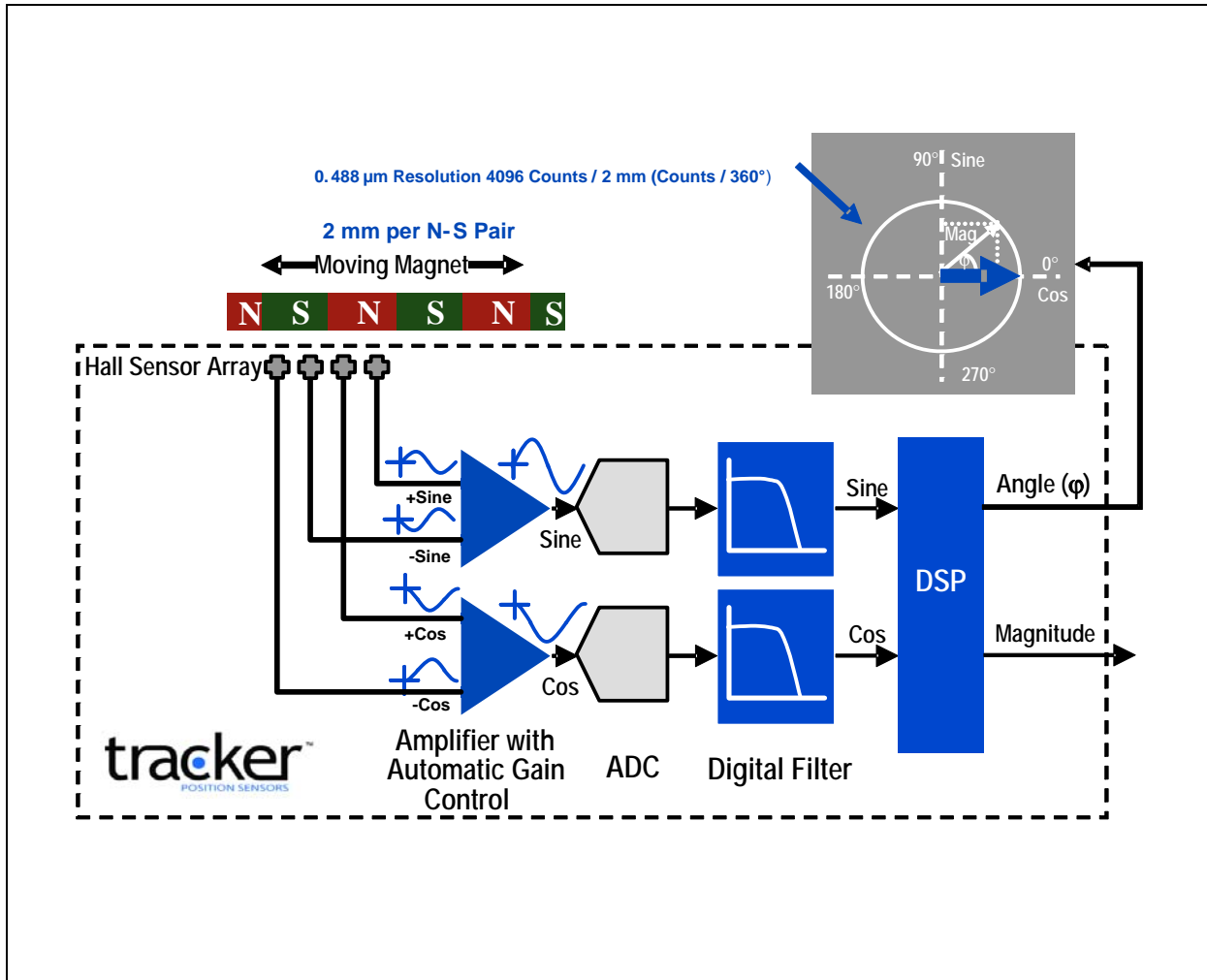


7 Detailed Description

The TRACKER measures the spatially varying magnetic field produced by moving a multi-pole magnetic strip over a Hall sensor array on the NSE-5310 chip (see Figure 3). The internal sinusoidal (SIN) and phase-shifted sinusoidal (COS) signals are filtered and transformed into angle (ANG) and magnitude (MAG), representing the absolute linear position within a 2 mm pole pair on the magnet. Interpolation with 12 bit (4096) resolution yields 0.5 μm position resolution. Automatic gain control (AGC) adjusts for DC bias in the magnetic field and provides a large magnetic field dynamic range for high immunity to external magnetic fields. The absolute magnitude of the magnetic field intensity is used to detect the end of the magnetic strip and serves as a built-in zero reference. The length of the magnetic strip determines the maximum measured stroke.

Note: Hall sensor array and on-chip digital encoder yield absolute position within a pole pair. Use a system processor to count pole pair crossings for long-range absolute position.

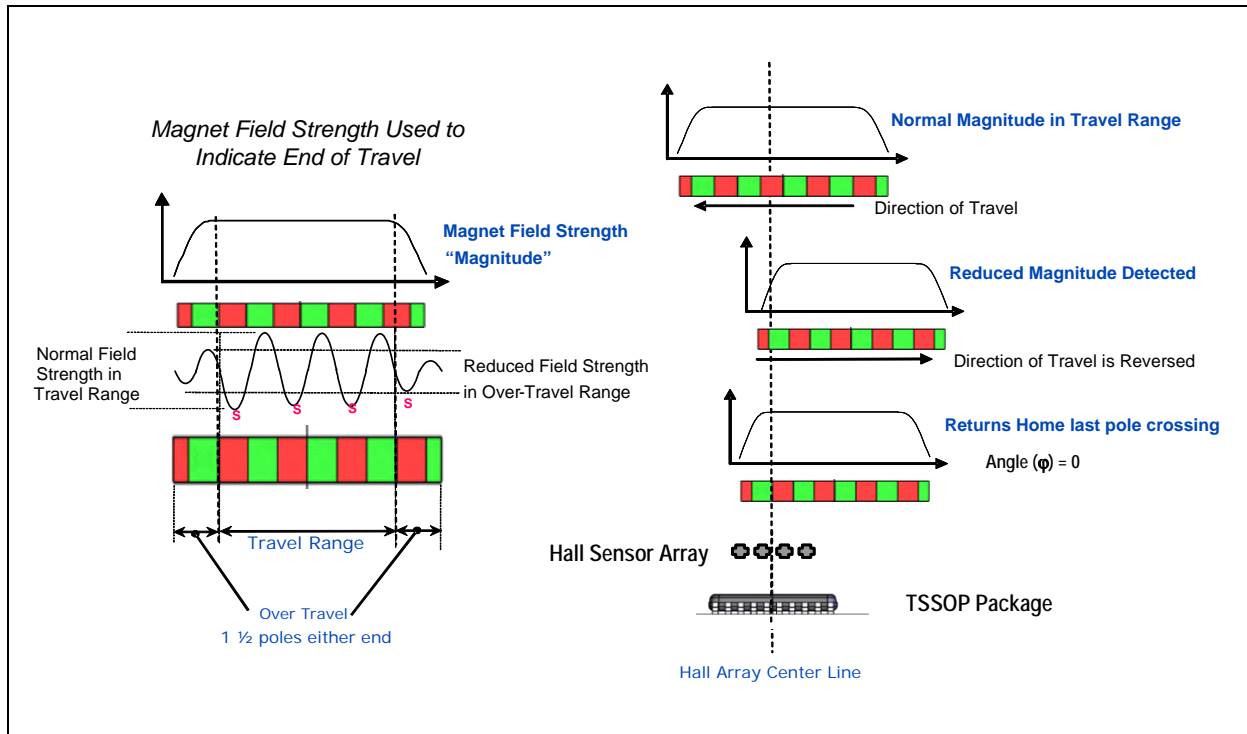
Figure 3. Hall Sensor Array



The over travel pole crossing provides a precision home position and eliminates the need for a secondary zero reference sensor.

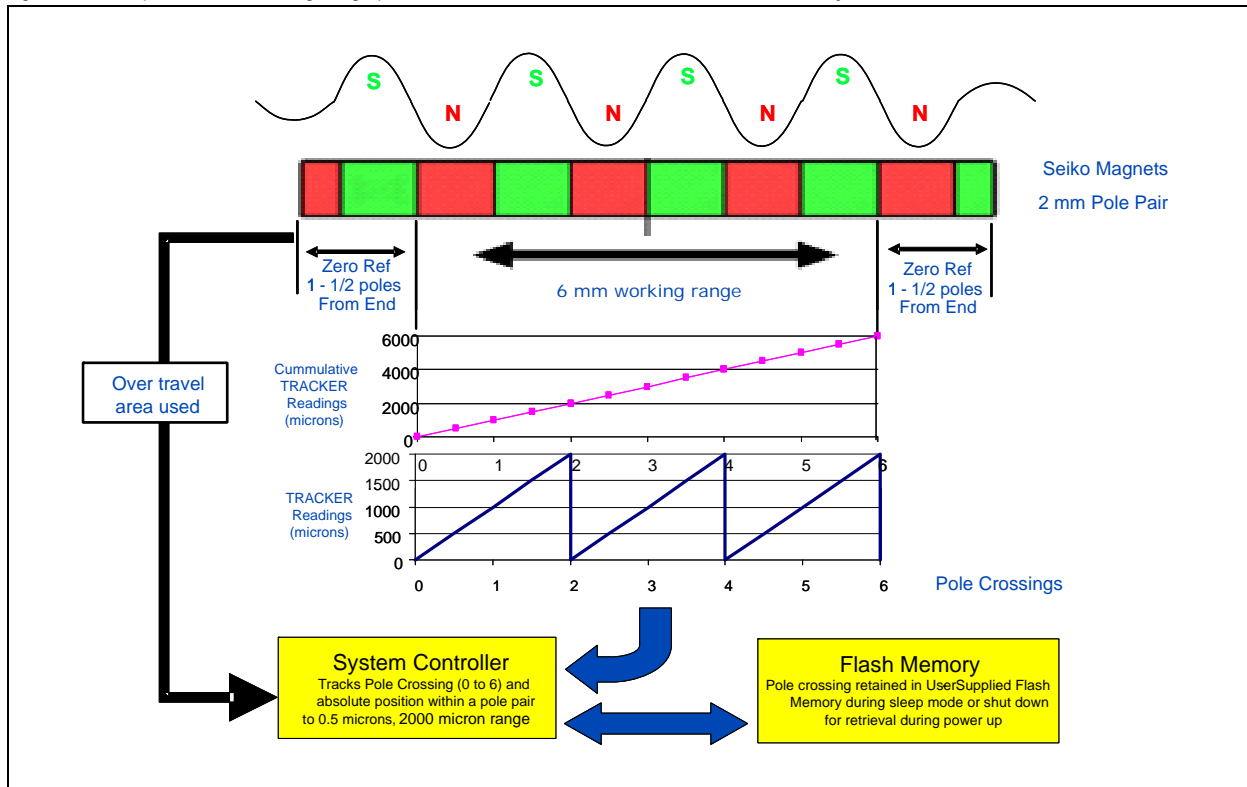


Figure 4. Magnetic Field Strength Used to Indicate End of Travel



A system controller and user-supplied flash memory with the TRACKER NSE-5310 provide for long-range absolute position information that is retained during sleep mode or power-down.

Figure 5. Example of Absolute long-range position information with use of external flash memory and controller





7.1 Using 3.3V or 5V Operation

For 3.3V operation: Bypass the voltage regulator (LDO) by connecting VDD3V3 with VDD5V.

For 5V operation: Connect the 5V supply to pin VDD5V. VDD3V3 (LDO output) must be buffered by a 2.2µF to 10µF capacitor placed close to the supply pin.

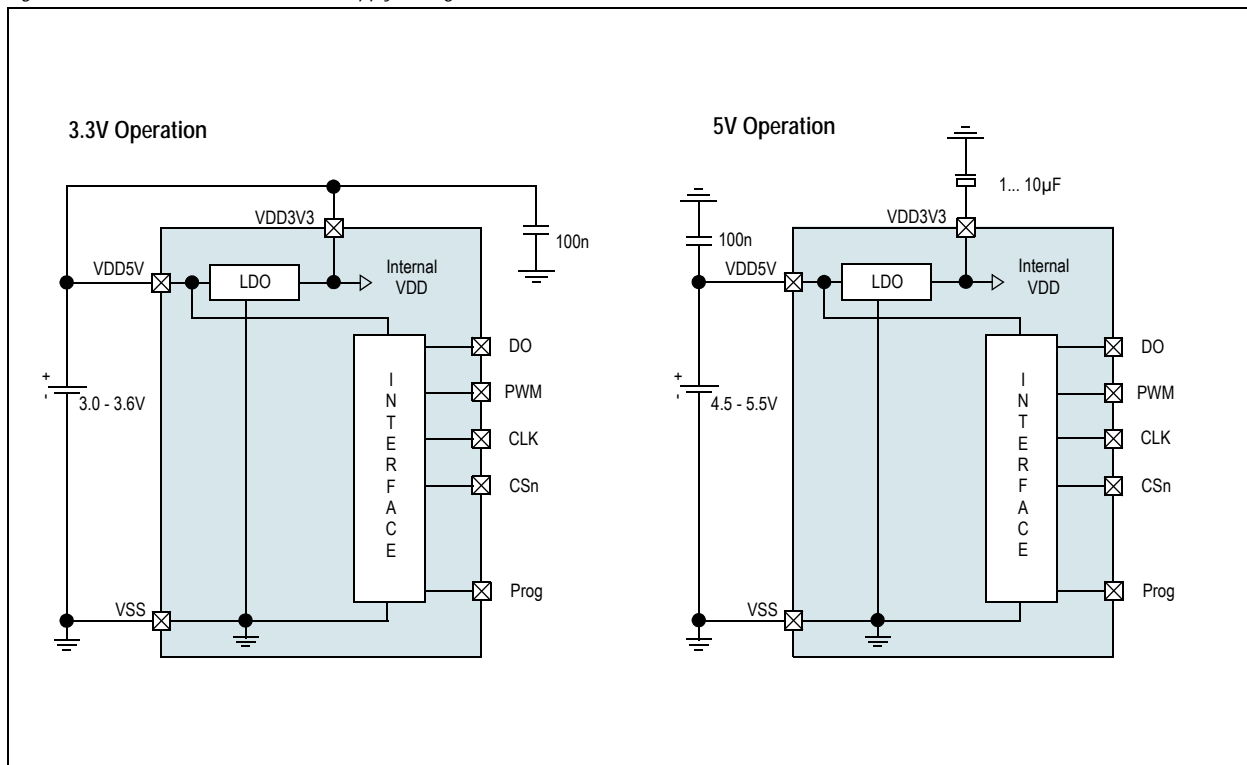
In either case, a buffer capacitor of 100nF close to pin VDD5V is recommended.

Note: Pin VDD3V3 must always be buffered by a capacitor. It must not be left floating, as this may cause an instable internal 3.3V supply voltage which may lead to larger than normal jitter of the measured position.

The 3V3 output is intended for internal use only. It must not be loaded with an external load.

The output voltage of the digital interface I/Os corresponds to the voltage at pin VDD5V, as the I/O buffers are supplied from this pin.

Figure 6. Connections for 3.3V or 5V Supply Voltage





8 Application Information

Figure 7. TRACKER NSE-5310 Evaluation Board

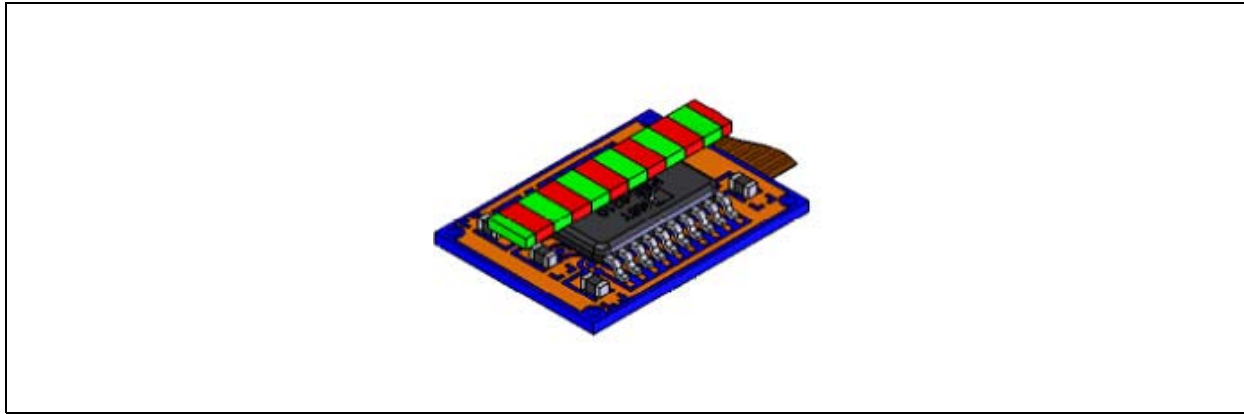


Figure 7 shows NSE-5310 mounted on a PCB with FPC connector for ease of handling. A multipole linear magnetic strip is positioned above the sensor.

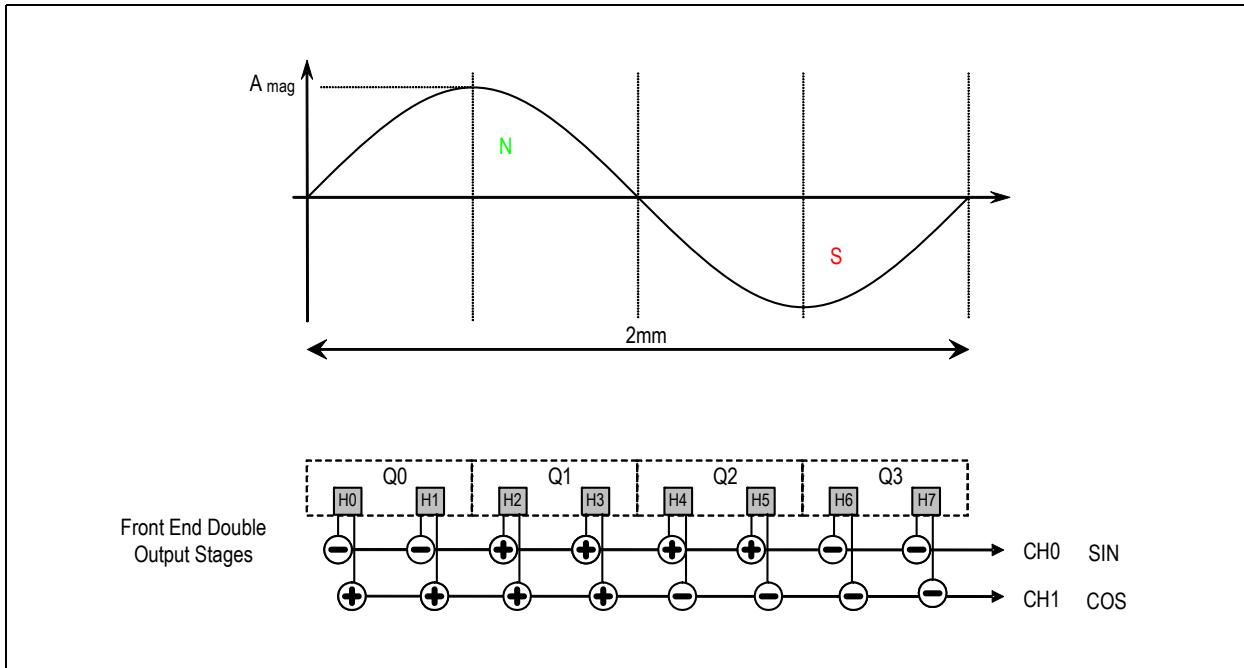
8.1 Hall Sensor Array

Eight Hall Sensor Front End cells are connected to two current summation busses which end into two Active Load circuits. The Hall elements are arranged in an even linear array. The array is divided into four quadrants. For normal operation (position encoding), two opposite quadrants are summed up differentially to neglect magnetic offsets. The 90 degree angular shift of the quadrant pairs produces 90 degree phase shifted SIN and COS signals for a harmonic input signal provided by a diametrically magnetized source.

Table 9. Hall Sensor Array Characteristics

Symbol	Parameter	Conditions	Min	Typ	Max	Units
G_{Array}	Array Gain	Double output stage		5.226		
d_{Array}	Array Length			2		mm

Figure 8. Hall Sensor FE Arrangement





8.2 Automatic Gain Control (AGC)

As the magnetic input field varies non-linearly with the air gap between sensor and magnet, the gain is controlled to an optimum input signal for the SD ADC. The magnitude output is compared to a target register value. The most significant eight bits are used. If the actual magnitude differs from the target value, an UP/DOWN signal for the AGC counter signal is generated.

For air gap detection functionality, two magnitude-change outputs are derived from the AGC counter UP/DOWN signals while the loop is controlling the amplitude back to the target amplitude. Magnitude Increasing (MagINCn) and Magnitude Decreasing (MagDECn) signals indicate air gap (SIN/COS amplitude) changes. Both signals are high for saturation of the AGC counter (running into upper / lower limit) and produce a Non-Valid-Range alarm. The output pins can be connected together in wired-OR configuration to produce a single NVRn bit. For faster power-up and response time, a successive approximation algorithm is implemented.

8.3 Temperature Sensor

The Temperature Sensor provides the junction temperature information over the serial interface.

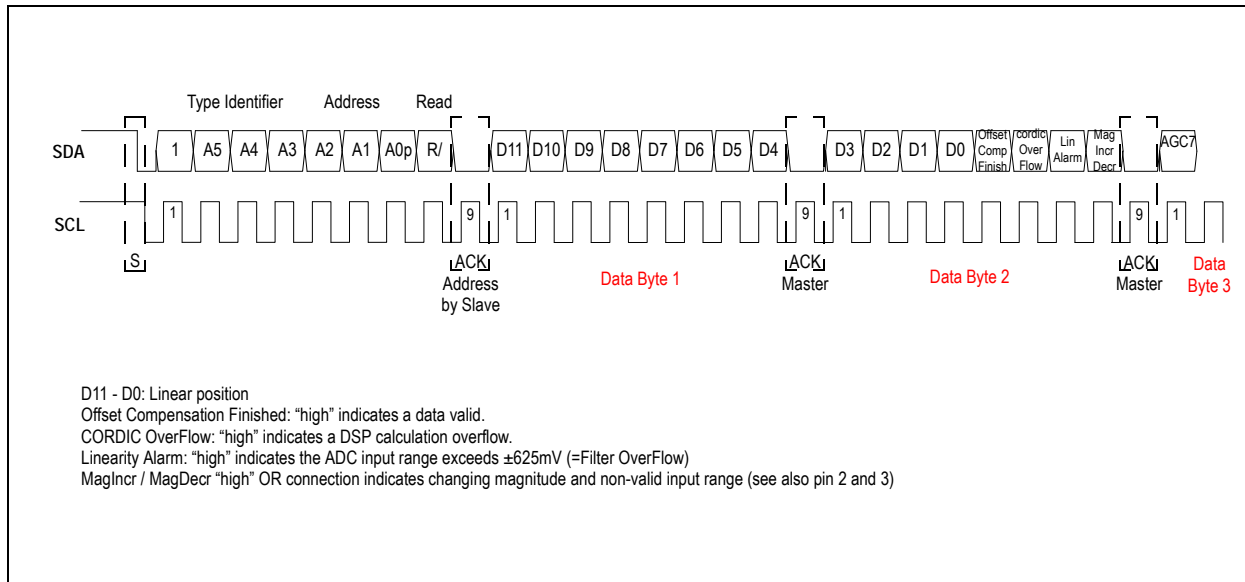
Table 10. Temperature Sensor Characteristics

Parameter	Conditions	Min	Typ	Max	Units
Absolute Error Trimmed	See I ² C User Interface on page 12			±10	°C
Conversion Rate	For continuous readout (1303 clock cycles between conversion)			767	sample/s
Temperature Range	Specified temperature range	-30		70	°C
Readout Range	Design limit for temperature range	-50		80	°C
Resolution	Temp [°C] = output code [LSB] x 0.667 [°C/LSB] - 75[°C]		8		bit
			0.667		°C/LSB
Clock Frequency	System clock (4 MHz) divided by 4			1	MHz

8.4 I²C User Interface

The device is accessible via an I²C two-wire serial interface. The default address is A<6:0>1000000. A<5:1> can be defined by the OTP I²C Address. A0 can be selected by pulling up pin 11 (default internal pull down). CSn (default internal pull up) must be low during I²C data transmission.

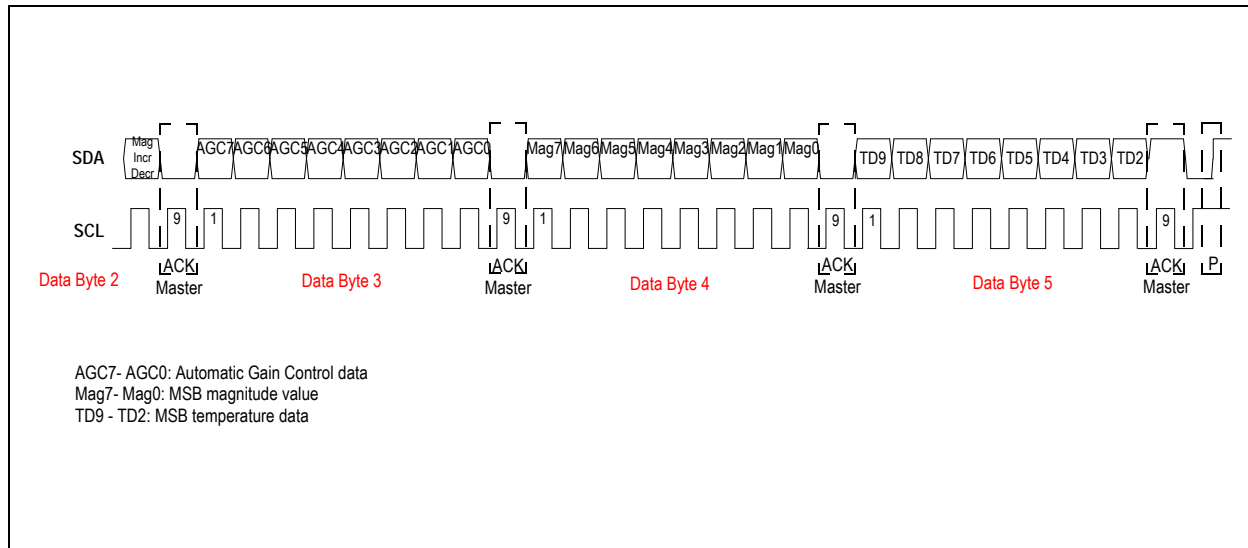
Figure 9. I²C Read Out by an μC-Master



In addition to the position data, magnitude and temperature sensor information can be read out as described in [Automatic Gain Control \(AGC\) on page 12](#) and [Temperature Sensor on page 12](#).



Figure 10. I²C Additional Information – Magnitude and Temperature Sensor



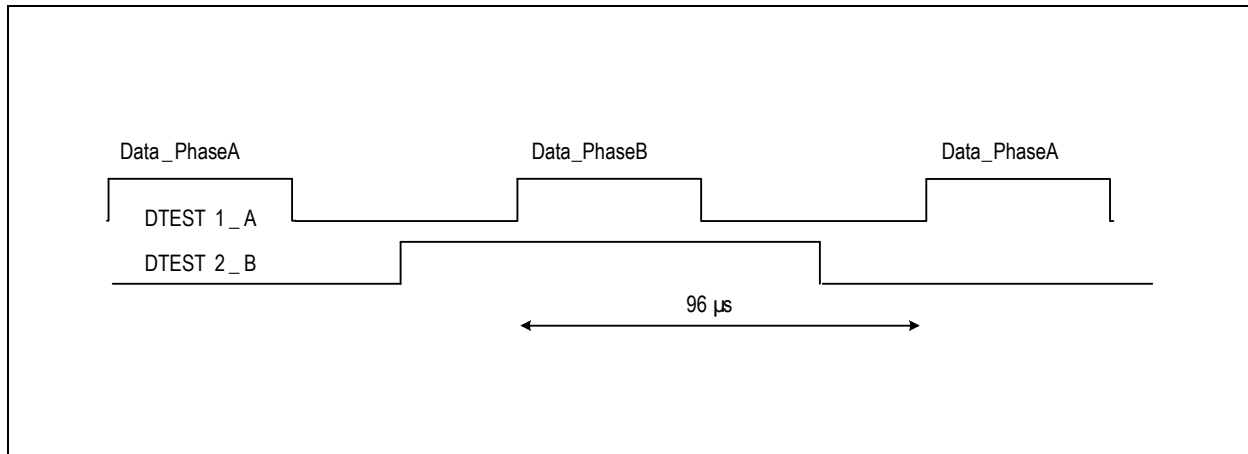
The information is sequenced by the order of priority during operation. Hence temperature readout is not needed for every access and magnitude information is only important if the AGC is out of range. The I²C readout can be stopped after every byte with the stop condition P. Timing constraints are according to I2C-Bus Specification V2.1 / 2000.

8.4.1 Sync Mode

This mode is used to synchronize the external electronics with the NSE-5310. In this mode two signals are provided at the pins DTEST_A and DTEST_B.

To activate sync mode, the internal trim bit for Sync Mode must be set. Please refer to Application Note AN5310-10.

Figure 11. Sync Mode



Every rising edge at DTEST1_A indicates that new data in the device is available. With this signal it is possible to trigger a μC (interrupt) and start the serial interface readout.



8.5 Z-axis Range Indication (“Red/Yellow/Green” Indicator)

The NSE-5310 provides several options of detecting the magnet distance by indicating the strength of the magnetic field. Signal indicators MagINCn and MagDECn are available both as hardware pins (pins 2 and 3) and as status bits in the serial data stream (see Figure 9). Additionally the LIN status bit indicates the non-recommended “red” range.

The digital status bits MagINC, MagDec, LIN and the hardware pins MagINCn, MagDECn have the following function:

Table 11. Magnetic Field Strength Red-Yellow-Green Indicators

Status Bits			MAG	Hardware Pins		
Mag INC	Mag DEC	Lin	M11... M0	Mag INCn	Mag DECn	Description
0	0	0	3F hex	OFF	OFF	No distance change Magnetic input field OK (GREEN range, ~10-40mT peak amplitude)
0	1	0	3F hex	OFF	OFF	Distance increase; this state is a dynamic state and only active while the magnet is moving away from the chip. Magnitude register may change but regulates back to 3F hex.
1	0	0	3F hex	OFF	OFF	Distance decrease; this state is a dynamic state and only active while the magnet is moving towards the chip. Magnitude register may change but regulates back to 3F hex.
1	1	0	20 hex - 5F hex	ON	OFF	YELLOW range: magnetic field is ~3.4-4.5mT. The device may still be operated in this range, but with slightly reduced accuracy.
1	1	1	<20 hex >5F hex	ON	ON	RED range: magnetic field is <3.4mT (MAG <20) or >5.5mT (MAG >5F). It is still possible to operate the device in the red range, but not recommended.

8.6 Pulse Width Modulation (PWM) Output

The NSE-5310 also provides a pulse width modulated output (PWM), whose duty cycle is proportional to the relative linear position of the magnet within one pole pair (2.0 mm). This cycle repeats after every subsequent pole pair:

$$Position = \frac{t_{on} \cdot 4098}{(t_{on} + t_{off})} - 1 \quad (EQ 1)$$

Where:

Digital position = 0 – 4094

Exception: A linear position of 1999.5µm = digital position 4095 will generate a pulse width of $t_{ON} = 4097\mu s$ and a pause $t_{OFF} = 1\mu s$

The PWM frequency is internally trimmed to an accuracy of $\pm 5\%$ ($\pm 10\%$ over full temperature range). This tolerance can be cancelled by measuring the complete duty cycle as shown above.

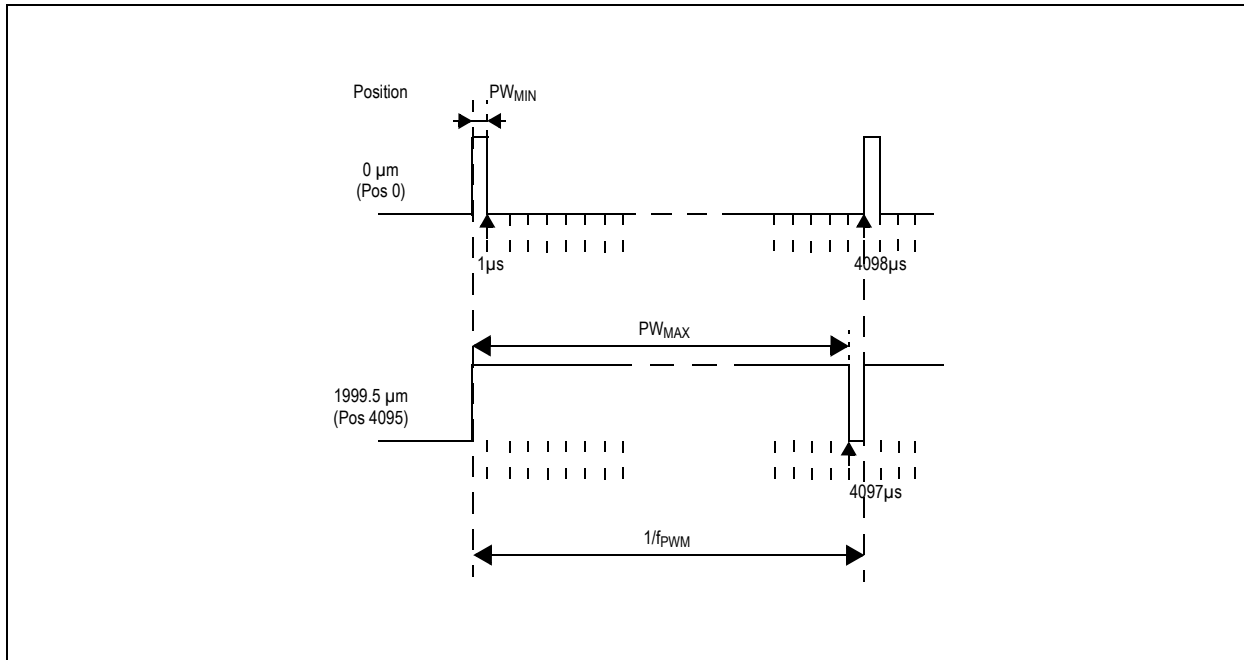
Operating Conditions: $T_{AMB} = -40$ to $+125^\circ C$, $V_{DD5V} = 3.0$ – $3.6V$ (3V operation) $V_{DD5V} = 4.5$ – $5.5V$ (5V operation) unless otherwise noted.

Table 12. PWM Output Timing Considerations

Symbol	Parameter	Conditions	Min	Typ	Max	Units
f_{PWM}	PWM frequency	Signal period = $4098\mu s \pm 5\%$ at $T_{AMB}=25^\circ C$	232	244	256	Hz
		= $4098\mu s \pm 10\%$ at $T_{AMB}= -40$ to $+125^\circ C$	220	244	268	
PW_{MIN}	Minimum pulse width	Position 0d = $0\mu m$	0.9	1	1.1	μs
PW_{MAX}	Maximum pulse width	Position 4095d = $1999.5\mu m$	3892	4097	4301	μs



Figure 12. PWM Output Signal



8.7 Magnetic Strip Requirements

The NSE-5310 requires a magnetic strip with alternate poles (North-South) of pole length of 1 mm and pole pair length of 2 mm. A half pole is required at each end of the strip. The length of the strip determines the maximum measured stroke; it must be 3 mm greater than the stroke in 1 mm increments (1.5 mm on each end).

A circular magnet may be used to achieve off-axis rotary encoding.

Table 13. Magnetic Strip Requirements

Parameter	Value	Note
Pole length	1 mm	
Pole pair length	2 mm ± 1.2%	Accuracy of magnetic pole length determines accuracy of linear measurement
Magnetic strip length	Stroke + 3 mm	The magnet strip must be in 1 mm increments. A ½ pole is required at each end.
Magnetic strip area	1 mm X 2 mm	Size recommended for TSSOP package
Magnetic field temp drift	-0.2%/K max	Recommended - for example Samarium Cobalt ReComa28 is -0.035%/K

8.7.1 Mounting the Magnet

Vertical Distance: As a rule of thumb, the gap between chip and magnet should be ½ of the pole length, that is Z=0.5mm for the 1.0mm pole length of the magnets. However, the gap also depends on the strength of the magnet. The NSE-5310 automatically adjusts for fluctuating magnet strength by using an automatic gain control (AGC). The vertical distance should be set such that the NSE-5310 is in the “green” range. See [Z-axis Range Indication \(“Red/Yellow/Green” Indicator\)](#) on page 14 for more details.

Alignment of Multi-pole Magnet and IC: When aligning the magnet strip or ring to the NSE-5310, the centerline of the magnet strip should be placed exactly over the Hall array. A lateral displacement in Y-direction (across the width of the magnet) is acceptable as long as it is within the active area of the magnet. The active area in width is the area in which the magnetic field strength across the width of the magnet is constant with reference to the centerline of the magnet.

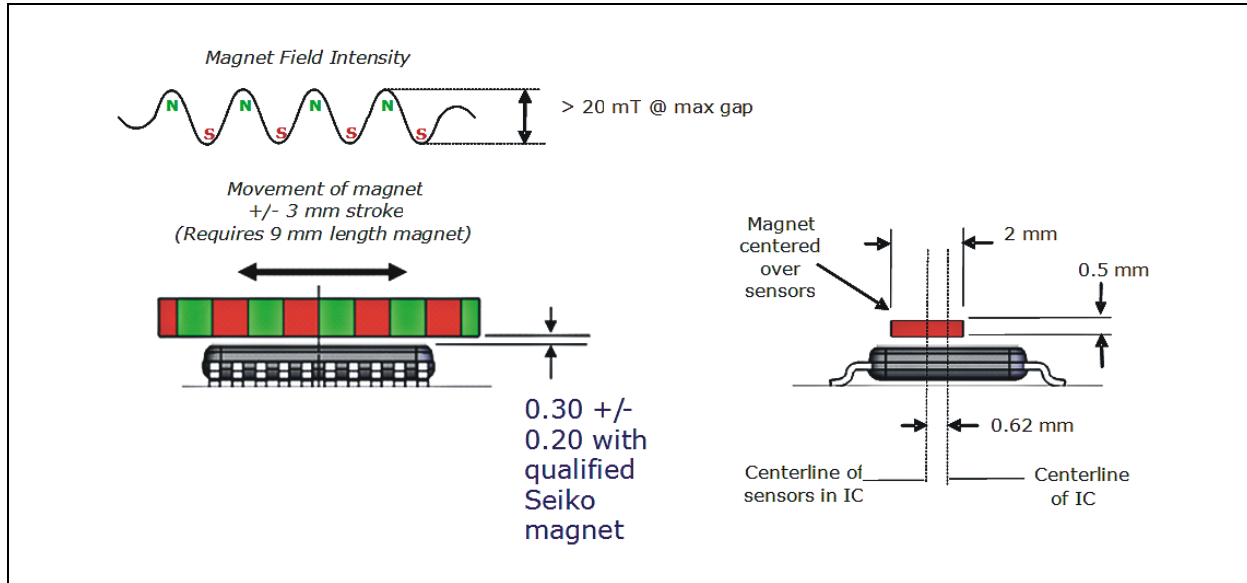


Lateral Stroke of Multi-pole Strip Magnets: The lateral movement range (stroke) is limited by the area at which all Hall sensors of the IC are covered by the magnet in either direction. The Hall array on the NSE-5310 has a length of 2.0mm, hence the total stroke is:

$$\text{maximum lateral Stroke} = \text{Length of active area} - \text{length of Hall array} \tag{EQ 2}$$

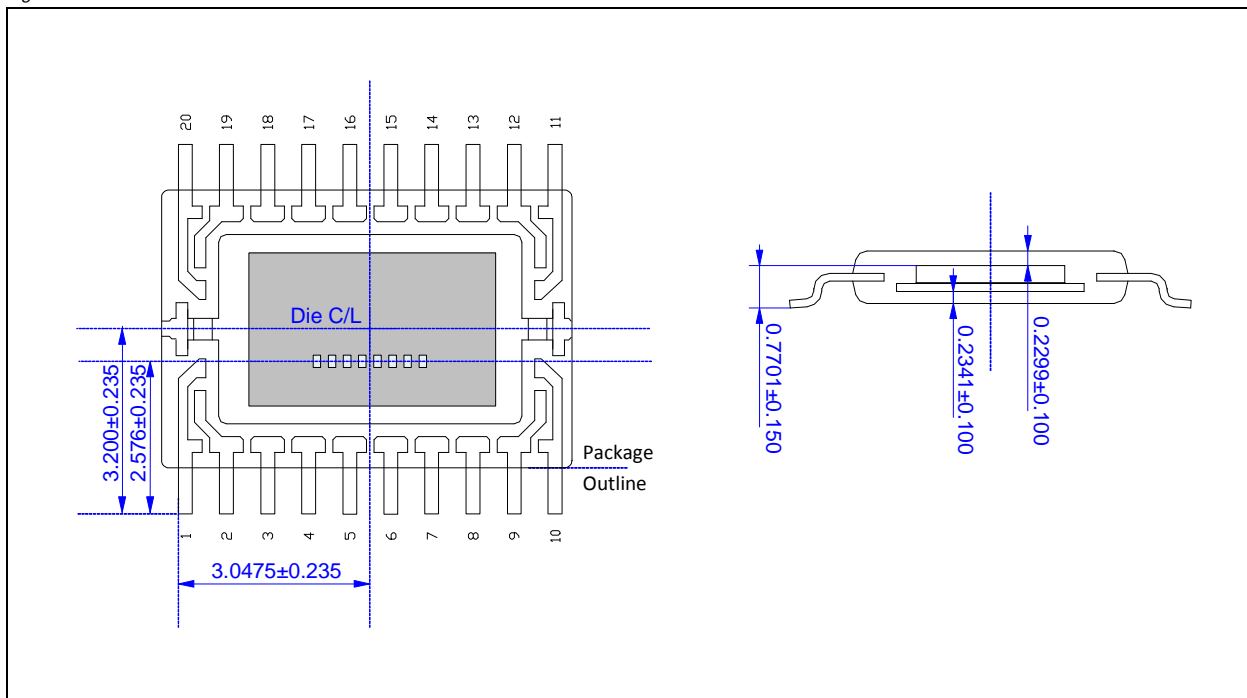
Note: Active area in length is defined as the area containing poles with the specified 1.0mm pole length. Shorter poles at either edge of the magnet must be excluded from the active area.

Figure 13. Magnetic Strip Alignment



Note: Further examples including use in off-axis rotary applications are shown in the “Magnet Selection Guide”, available for download at www.ams.com/eng/content/view/download/11922

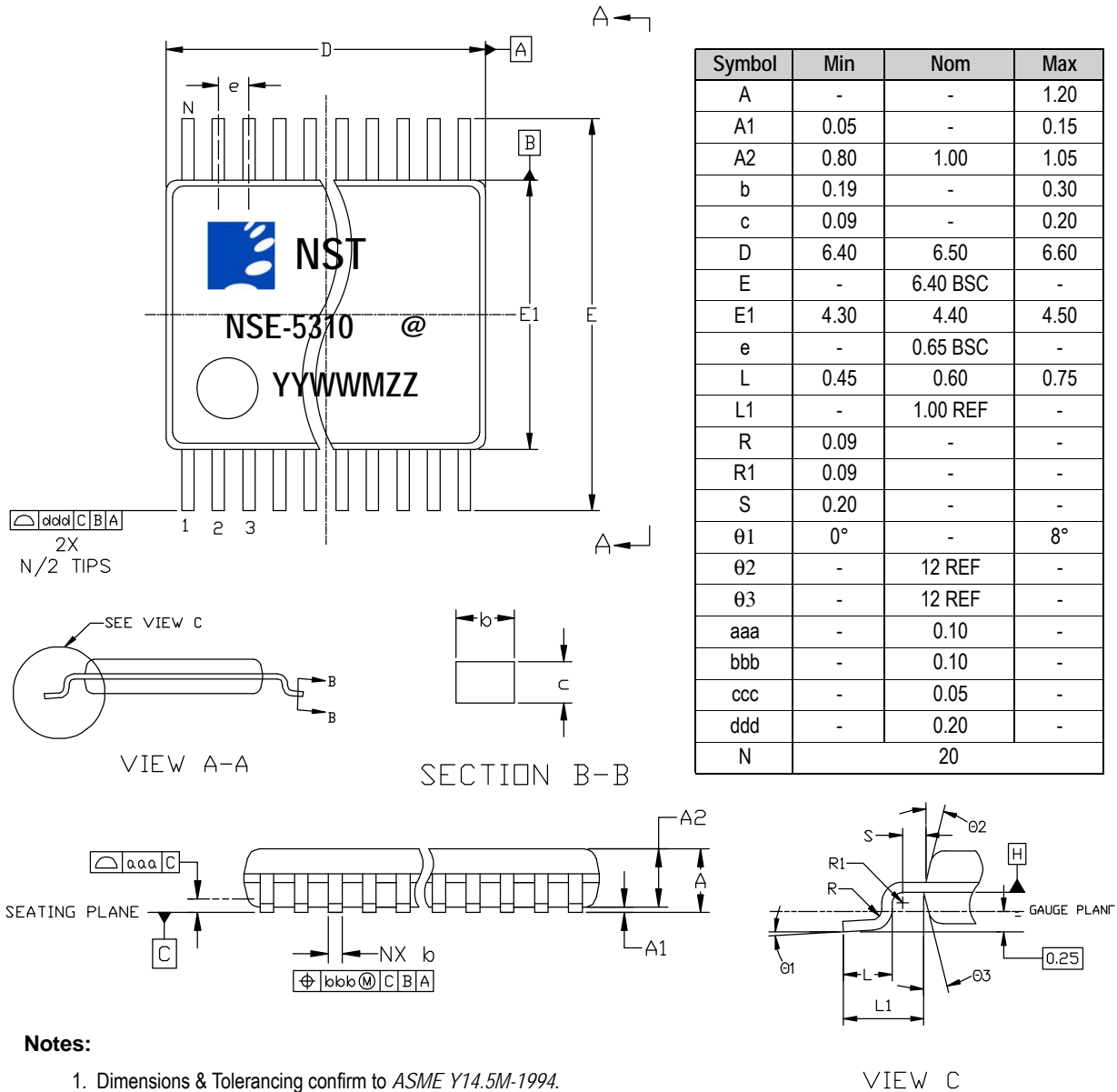
Figure 14. Vertical Cross Section





9 Package Drawings and Markings

Figure 15. 20-pin TSSOP Package



Marking: YYWWMZZ.

YY	WW	M	ZZ	@
Year	Manufacturing Week	Plant Identifier	Traceability Code	Sublot Identifier

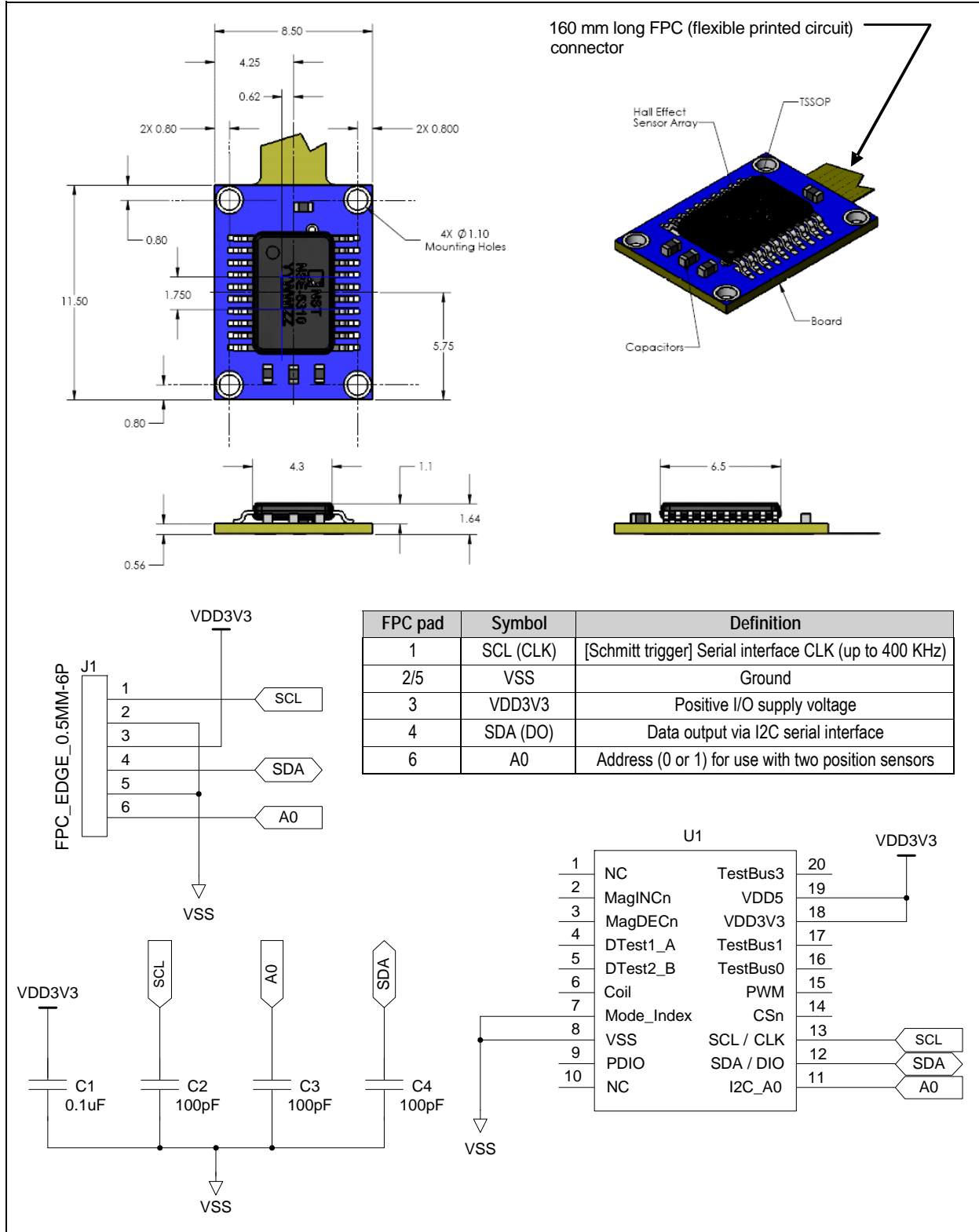
JEDEC Package Outline Standard: MO - 153

Thermal Resistance $R_{th(j-a)}$: 89 K/W in still air, soldered on PCB



The evaluation kit includes an NSE-5310 mounted in a TSSOP 20 package with flex cable, for easy handling during evaluation and system development. The TRK-1T02-E evaluation pack includes a TRK-1T02 along with a suitable linear magnetic strip, a MC-31MB interface card and New Scale Pathway™ software with intuitive user interface to facilitate evaluation.

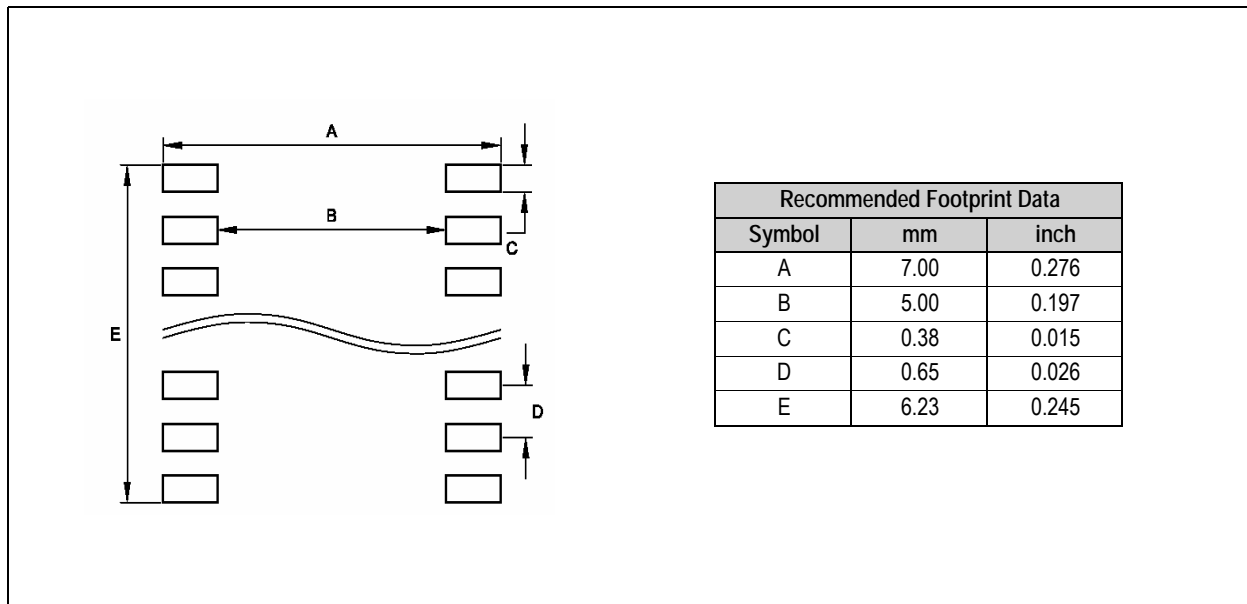
Figure 16. TRK-1T02 Package for Easy Handling During Evaluation





9.1 Recommended PCB Footprint

Figure 17. PCB Footprint





Revision History

Revision	Date	Owner	Description
1.0	03 Aug, 2007		Initial version
1.1	06 Jan, 2012	rph	Updated Table 1 and Section 8.4.1 Sync Mode Added logos to Package Drawings and Markings on page 17
1.2	19 Nov, 2012		Updated package diagrams and added Recommended PCB Footprint
1.3	09 Jan, 2013		Added Figure 14 and updated Absolute Maximum Ratings
1.4	06 Mar, 2013		Updated Ordering Information
	20 Mar, 2013		Updates carried out in Absolute Maximum Ratings on page 4 and removed SOIC info.
1.5	30 May, 2013		Updated Section 8.4 I ² C User Interface

Note: Typos may not be explicitly mentioned under revision history.



10 Ordering Information

The devices are available as the standard products shown in [Table 14](#).

Table 14. Ordering Information

Ordering Code	Description	Delivery Form	Package
TRK-1T02-E Evaluation Pack	Includes TRK-1T02 position sensor, MC-31MB interface card, New Scale pathway software		
NSE-5310ASSU	Encoder, TSSOP-20	Tube	TSSOP-20
NSE-5310ASST		Tape & Reel	TSSOP-20
Custom chip-on-board	Inquire for details		

Note: All products are RoHS compliant and ams green.
Buy our products or get free samples online at www.ams.com/ICdirect

Technical Support is available at www.ams.com/Technical-Support

For further information and requests, email us at sales@ams.com
(or) find your local distributor at www.ams.com/distributor



Copyrights

Copyright © 1997-2013, ams AG, Tobelbaderstrasse 30, 8141 Unterpremstaetten, Austria-Europe. Trademarks Registered ®. All rights reserved. The material herein may not be reproduced, adapted, merged, translated, stored, or used without the prior written consent of the copyright owner.

All products and companies mentioned are trademarks or registered trademarks of their respective companies.

Disclaimer

Devices sold by ams AG are covered by the warranty and patent indemnification provisions appearing in its Term of Sale. ams AG makes no warranty, express, statutory, implied, or by description regarding the information set forth herein or regarding the freedom of the described devices from patent infringement. ams AG reserves the right to change specifications and prices at any time and without notice. Therefore, prior to designing this product into a system, it is necessary to check with ams AG for current information. This product is intended for use in normal commercial applications. Applications requiring extended temperature range, unusual environmental requirements, or high reliability applications, such as military, medical life-support or life-sustaining equipment are specifically not recommended without additional processing by ams AG for each application. For shipments of less than 100 parts the manufacturing flow might show deviations from the standard production flow, such as test flow or test location.

The information furnished here by ams AG is believed to be correct and accurate. However, ams AG shall not be liable to recipient or any third party for any damages, including but not limited to personal injury, property damage, loss of profits, loss of use, interruption of business or indirect, special, incidental or consequential damages, of any kind, in connection with or arising out of the furnishing, performance or use of the technical data herein. No obligation or liability to recipient or any third party shall arise or flow out of ams AG rendering of technical or other services.



Contact Information

Headquarters

ams AG
Tobelbaderstrasse 30
A-8141 Unterpremstaetten, Austria

Tel : +43 (0) 3136 500 0
Fax : +43 (0) 3136 525 01

For Sales Offices, Distributors and Representatives, please visit:
<http://www.ams.com/contact>



Contact Information

New Scale Technologies, Inc.
121 Victor Heights Parkway
Victor, NY 14564

Tel: +1 585 924 4450
Fax: +1 585 924 4468

sales@newscaletech.com

www.newscaletech.com