

Product Overview

The NSI8021 devices are high reliability dual-channel digital isolator. It is safety certified by UL1577 support 3kV_{rms} insulation withstand voltages, while providing high electromagnetic immunity and low emissions at low power consumption. The data rate of the NSI8021 is up to 10Mbps, and the common-mode transient immunity (CMTI) is up to 100kV/us. The NSI8021 device provides the default output high level when the input power is lost. Wide supply voltage of the NSI8021 device support to connect with most digital interface directly, easy to do the level shift. High system level EMC performance enhance reliability and stability of use.

Key Features

- Up to 3000V_{rms} Insulation voltage
- Data rate: DC to 10Mbps
- Power supply voltage: 2.5V to 5.5V
- High CMTI: 100kV/us
- Chip level ESD: HBM: ±4kV
- High system level EMC performance:
 - Enhanced system level ESD, EFT, Surge immunity
- Default output high level or low level option
- Isolation barrier life: >40 years
- Low power consumption: 1.5mA/ch (10Mbps)
- Propagation delay: <45ns
- Operation temperature: -40°C~125°C
- RoHS-compliant packages:
 - SOIC-8 narrow body



Safety Regulatory Approvals

- UL recognition: up to 3000V_{rms} for 1 minute per UL1577
- CQC certification per GB4943.1-2011
- CSA component notice 5A
- DIN VDE V 0884-11:2017-01

Applications

- Industrial automation system
- Isolated SPI, RS232, RS485
- General-purpose multichannel isolation
- Battery management system

Functional Block Diagrams

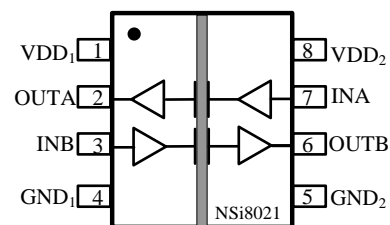

Figure 1. NSI8021N Block Diagram

Index

1.0	ABSOLUTE MAXIMUM RATINGS	3
2.0	SPECIFICATIONS	3
2.1.	ELECTRICAL CHARACTERISTICS	3
2.2.	PARAMETER MEASUREMENT INFORMATION	6
3.0	HIGH VOLTAGE FEATURE DESCRIPTION	7
3.1.	INSULATION AND SAFETY RELATED SPECIFICATIONS	7
3.2.	DIN VDE V 0884-11 (VDE V 0884-11) :2017-01 INSULATION CHARACTERISTICS	7
3.3.	REGULATORY INFORMATION.....	9
4.0	FUNCTION DESCRIPTION	9
5.0	APPLICATION NOTE	10
5.1.	PCB LAYOUT.....	10
6.0	PACKAGE INFORMATION	10
7.0	TAPE AND REEL INFORMATION	11
8.0	ORDER INFORMATION	13
9.0	REVISION HISTORY	13

1.0 ABSOLUTE MAXIMUM RATINGS

Parameters	Symbol	Min	Typ	Max	Unit	Comments
Power Supply Voltage	VDD1, VDD2	-0.5		6.5	V	
Maximum Input Voltage	VINA, VINB	-0.4		VDD+0.4 ¹	V	
Maximum Output Voltage	V _{OUTA} , V _{OUTB}	-0.4		VDD+0.4 ¹	V	
Maximum Input/Output Pulse Voltage	VINA, VINB, V _{OUTA} , V _{OUTB}	-0.8		VDD+0.8	V	Pulse width should be less than 100ns, and the duty cycle should be less than 10%
Common-Mode Transients	CMTI			±100	kV/us	
Output current	I _o	-15		15	mA	
Maximum Surge Isolation Voltage	V _{IOSM}			6.1	kV	
Operating Temperature	T _{opr}	-40		125	°C	
Junction Temperature	T _j	-40		150	°C	
Electrostatic discharge	HBM			±6000	V	
	CDM			±2000	V	

¹The maximum voltage must not exceed 6.5V.

2.0 SPECIFICATIONS

2.1. RECOMMENDED OPERATING CONDITIONS

Parameters	Symbol	min	typ	max	unit
Power Supply Voltage	VDD1, VDD2	2.5		5.5	V
Operating Temperature	T _{opr}	-40		125	°C
High Level Input Voltage	V _{IH}	2			V
Low Level Input Voltage	V _{IL}			0.8	V
Data rate	DR			10	Mbps

2.2. THERMAL CHARACTERISTICS

Parameters	Symbol	WB SOIC-16	NB-SOIC-8	Unit
IC Junction-to-Air Thermal Resistance	θ _{JA}	86.5	137.7	° C/W
Junction-to-case (top) thermal resistance	θ _{JC (top)}	49.6	54.9	° C/W
Junction-to-board thermal resistance	θ _{JB}	49.7	71.7	° C/W

2.3. ELECTRICAL CHARACTERISTICS

(VDD1=2.5V~5.5V, VDD2=2.5V~5.5V, Ta=-40°C to 125°C. Unless otherwise noted, Typical values are at VDD1 = 5V, VDD2 = 5V, Ta = 25°C)

Parameters	Symbol	Min	Typ	Max	Unit	Comments
Power on Reset	VDD _{POR}		2.2		V	POR threshold as during power-up
	VDD _{HYS}		0.1		V	POR threshold Hysteresis
High Level Input Voltage	V _{IH}	0.7*VDD			V	
Low Level Input Voltage	V _{IL}			0.3*VDD	V	
High Level Output Voltage	V _{OH}	VDD-0.4			V	I _{OH} ≤ 4mA
Low Level Output Voltage	V _{OL}			0.4	V	I _{OL} ≤ 4mA
Output Impedance	R _{out}		50		ohm	
Input Pull high or low Current	I _{pull}		8	15	uA	
Start Up Time after POR	trbs		40		usec	
Common Mode Transient Immunity	CMTI	±80		±100	kV/us	

(VDD1=5V± 10%, VDD2=5V± 10%, Ta=-40°C to 125°C. Unless otherwise noted, Typical values are at VDD1 = 5V, VDD2 = 5V, Ta = 25°C)

Parameters	Symbol	Min	Typ	Max	Unit	Comments
Supply current	NSI8021					
	I _{DD1} (Q0)		1.48	2.2	mA	All Input at 0V
	I _{DD2} (Q0)		1.48	2.2	mA	
	I _{DD1} (Q1)		0.92	1.35	mA	All Input at supply
	I _{DD2} (Q1)		0.92	1.35	mA	
	I _{DD1} (1M)		1.24	1.86	mA	All Input with 1Mbps, C _L =15pF
	I _{DD2} (1M)		1.24	1.86	mA	
	I _{DD1} (10M)		1.58	2.37	mA	All Input with 10Mbps, C _L =15pF
I _{DD2} (10M)		1.58	2.37	mA		
Data Rate	DR	0		10	Mbps	
Minimum Pulse Width	PW			50.0	ns	
Propagation Delay	t _{PLH}		32.32	45	ns	See Figure 2.7 , C _L = 15pF
	t _{PHL}		33.86	45	ns	See Figure 2.7 , C _L = 15pF
Pulse Width Distortion	PWD		1.54	10.0	ns	See Figure 2.7 , C _L = 15pF

$ t_{PHL} - t_{PLH} $						
Rising Time	t_r			5.0	ns	See Figure 2.7 , $C_L = 15pF$
Falling Time	t_f			5.0	ns	See Figure 2.7 , $C_L = 15pF$
Peak Eye Diagram Jitter	$t_{JIT}(PK)$		350		ps	
Channel-to-Channel Delay Skew	$t_{SK}(c2c)$			10.0	ns	
Part-to-Part Delay Skew	$t_{SK}(p2p)$			10.0	ns	

(VDD1=3.3V± 10%, VDD2=3.3V± 10%, Ta=-40°C to 125°C. Unless otherwise noted, Typical values are at VDD1 = 3.3V, VDD2 = 3.3V, Ta = 25°C)

Parameters	Symbol	Min	Typ	Max	Unit	Comments
NSI8021						
Supply current	$I_{DD1}(Q0)$		1.41	2.1	mA	All Input at 0V
	$I_{DD2}(Q0)$		1.41	2.1	mA	
	$I_{DD1}(Q1)$		0.85	1.27	mA	All Input at supply
	$I_{DD2}(Q1)$		0.85	1.27	mA	
	$I_{DD1}(1M)$		1.16	1.74	mA	All Input with 1Mbps, $C_L=15pF$
	$I_{DD2}(1M)$		1.16	1.74	mA	
	$I_{DD1}(10M)$		1.41	2.12	mA	All Input with 10Mbps, $C_L=15pF$
	$I_{DD2}(10M)$		1.41	2.12	mA	
Data Rate	DR	0		10	Mbps	
Minimum Pulse Width	PW			50.0	ns	
Propagation Delay	t_{PLH}		33.19	45	ns	See Figure 2.7 , $C_L = 15pF$
	t_{PHL}		31.94	45	ns	See Figure 2.7 , $C_L = 15pF$
Pulse Width Distortion $ t_{PHL} - t_{PLH} $	PWD		1.25	10.0	ns	See Figure 2.7 , $C_L = 15pF$
Rising Time	t_r			5.0	ns	See Figure 2.7 , $C_L = 15pF$
Falling Time	t_f			5.0	ns	See Figure 2.7 , $C_L = 15pF$
Peak Eye Diagram Jitter	$t_{JIT}(PK)$		350		ps	
Channel-to-Channel Delay Skew	$t_{SK}(c2c)$			10.0	ns	
Part-to-Part Delay Skew	$t_{SK}(p2p)$			10.0	ns	

NSI8021

(VDD1=2.5V± 10%, VDD2=2.5V± 10%, Ta=-40°C to 125°C. Unless otherwise noted, Typical values are at VDD1 = 2.5V, VDD2 = 2.5V, Ta = 25°C)

Parameters	Symbol	Min	Typ	Max	Unit	Comments
NSI8021						
Supply current	I _{DD1} (Q0)		1.37	2.05	mA	All Input at 0V
	I _{DD2} (Q0)		1.37	2.05	mA	
	I _{DD1} (Q1)		0.82	1.23	mA	All Input at supply
	I _{DD2} (Q1)		0.82	1.23	mA	
	I _{DD1} (1M)		1.12	1.68	mA	All Input with 1Mbps, C _L =15pF
	I _{DD2} (1M)		1.12	1.68	mA	
	I _{DD1} (10M)		1.33	2.00	mA	All Input with 10Mbps, C _L =15pF
	I _{DD2} (10M)		1.33	2.00	mA	
Data Rate	DR	0		10	Mbps	
Minimum Pulse Width	PW			50.0	ns	
Propagation Delay	t _{PLH}		33.07	45	ns	See Figure 2.7 , C _L = 15pF
	t _{PHL}		31.90	45	ns	See Figure 2.7 , C _L = 15pF
Pulse Width Distortion t _{PHL} - t _{PLH}	PWD		1.17	10.0	ns	See Figure 2.7 , C _L = 15pF
Rising Time	t _r			5.0	ns	See Figure 2.7 , C _L = 15pF
Falling Time	t _f			5.0	ns	See Figure 2.7 , C _L = 15pF
Peak Eye Diagram Jitter	t _{JIT} (PK)		350		ps	
Channel-to-Channel Delay Skew	t _{SK} (c2c)			10.0	ns	
Part-to-Part Delay Skew	t _{SK} (p2p)			10.0	ns	

2.4. PARAMETER MEASUREMENT INFORMATION

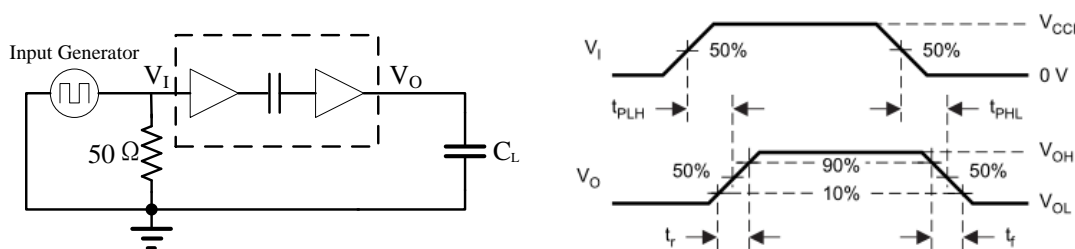

Figure 2.7 Switching Characteristics Test Circuit and Waveform

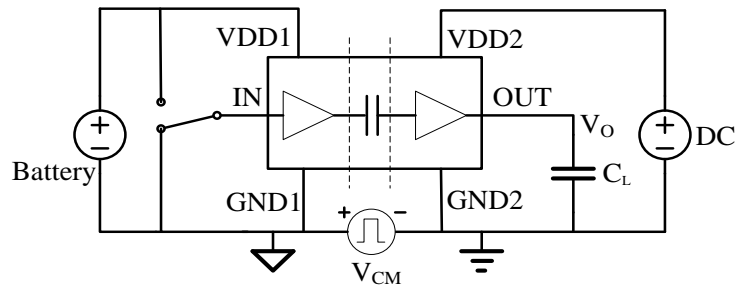

Figure 2.8 Common-Mode Transient Immunity Test Circuit

3.0 HIGH VOLTAGE FEATURE DESCRIPTION

3.1. INSULATION AND SAFETY RELATED SPECIFICATIONS

Parameters	Symbol	Value	Unit	Comments
		SOIC-8		
Minimum External Air Gap (Clearance)	L(I01)	4.0	mm	Shortest terminal-to-terminal distance through air
Minimum External Tracking (Creepage)	L(I02)	4.0	mm	Shortest terminal-to-terminal distance across the package surface
Minimum internal gap	DTI	20	um	Distance through insulation
Tracking Resistance(Comparative Tracking Index)	CTI	>400	V	DIN EN 60112 (VDE 0303-11); IEC 60112
Material Group		II		

3.2. DIN VDE V 0884-11 (VDE V 0884-11) :2017-01 INSULATION CHARATERISTICS

Description	Test Condition	Symbol	Value	Unit
			SOIC-8	
Installation Classification per DIN VDE 0110				
For Rated Mains Voltage $\leq 150V_{rms}$			I to IV	
For Rated Mains Voltage $\leq 300V_{rms}$			I to III	
For Rated Mains Voltage $\leq 400V_{rms}$			I to III	
Climatic Classification			10/105/21	
Pollution Degree per DIN VDE 0110, Table 1			2	

Maximum repetitive isolation voltage		VIORM	565	Vpeak
Input to Output Test Voltage, Method B1	$V_{IORM} \times 1.5 = V_{pd(m)}$, 100% production test, $t_{ini} = t_m = 1$ sec, partial discharge < 5 pC	$V_{pd(m)}$	847	Vpeak
Input to Output Test Voltage, Method A				
After Environmental Tests Subgroup 1	$V_{IORM} \times 1.2 = V_{pd(m)}$, $t_{ini} = 60$ sec, $t_m = 10$ sec, partial discharge < 5 pC	$V_{pd(m)}$	678	Vpeak
After Input and /or Safety Test Subgroup 2 and Subgroup 3	$V_{IORM} \times 1.2 = V_{pd(m)}$, $t_{ini} = 60$ sec, $t_m = 10$ sec, partial discharge < 5 pC	$V_{pd(m)}$	678	Vpeak
Maximum transient isolation voltage	$t = 60$ sec	VIOTM	5300	Vpeak
Maximum Surge Isolation Voltage	Test method per IEC60065, 1.2/50us waveform, $V_{TEST} = V_{IOSM} \times 1.3$	VIOSM	6153	Vpeak
Isolation resistance	$V_{IO} = 500V$	RIO	$>10^9$	Ω
Isolation capacitance	$f = 1MHz$	CIO	0.6	pF
Input capacitance		CI	2	pF
Total Power Dissipation at 25°C		Ps	1100	mW
Safety input, output, or supply current	$\theta_{JA} = 137.7^\circ C/W$, $V_I = 5.5 V$, $T_J = 150^\circ C$, $T_A = 25^\circ C$	Is	200	mA
Case Temperature		Ts	150	°C

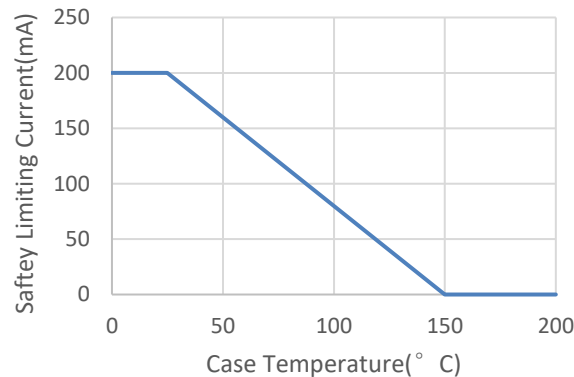

Figure 3.1 NSI8021N Thermal Derating Curve, Dependence of Safety Limiting Values with Case Temperature per DIN VDE V 0884-11

3.3. REGULATORY INFORMATION

The NSI8021N are approved by the organizations listed in table.

	<i>CUL</i>	<i>VDE</i>	<i>CQC</i>
UL 1577 Component Recognition Program ¹	Approved under CSA Component Acceptance Notice 5A	DIN VDE V 0884-11:2017-01 ²	Certified by CQC11-471543-2012 GB4943.1-2011
Single Protection, 3000V _{rms} Isolation voltage	Single Protection, 3000V _{rms} Isolation voltage	Basic Insulation 565V _{peak} , V _{IOSM} =6153V _{peak}	Basic insulation at 400V _{rms} (565V _{peak})
File (E500602)	File (E500602)	File (5024579-4880-0001)	File (pending)

¹ In accordance with UL 1577, each NSI8021N is proof tested by applying an insulation test voltage ≥ 3600 V_{rms} for 1 sec.

² In accordance with DIN VDE V 0884-11, each NSI8021N is proof tested by applying an insulation test voltage ≥ 847 V peak for 1 sec (partial discharge detection limit = 5 pC). The * marking branded on the component designates DIN VDE V 0884-11 approval.

4.0 FUNCTION DESCRIPTION

The NSI8021 is a Dual-channel digital isolator based on a capacitive isolation barrier technique. The digital signal is modulated with RF carrier generated by the internal oscillator at the Transmitter side. Then it is transferred through the capacitive isolation barrier and demodulated at the Receiver side.

The NSI8021 devices are high reliability dual-channel digital isolator. The NSI8021 device is safety certified by UL1577 support 3kV_{rms} insulation withstand voltage, while providing high electromagnetic immunity and low emissions at low power consumption. The data rate of the NSI8021 is up to 10Mbps, and the common-mode transient immunity (CMTI) is up to 100kV/us. The NSI8021 device provides the default output high level when the input power is lost. Wide supply voltage of the NSI8021 device support to connect with most digital interface directly, easy to do the level shift. High system level EMC performance enhance reliability and stability of use.

The NSI8021 has a default output status when VDDIN is unready and VDDOUT is ready as shown in Table 4.1, which helps for diagnosis when power is missing at the transmitter side. The output B follows the same status with the input A within 60us after powering up.

Table 4.1 Output status vs. power status

<i>Input</i>	<i>VDD1 status</i>	<i>VDD2 status</i>	<i>Output</i>	<i>Comment</i>
H	Ready	Ready	H	Normal operation.
L	Ready	Ready	L	
X	Unready	Ready	H	The output follows the same status with the input within 60us after input side VDD1 is powered on.
X	Ready	Unready	X	The output follows the same status with the input within 60us after output side VDD2 is powered on.

5.0 APPLICATION NOTE

5.1. PCB LAYOUT

The NSI8021 requires a 0.1 μF bypass capacitor between VDD1 and GND1, VDD2 and GND2. The capacitor should be placed as close as possible to the package. Figure 5.1 to Figure 5.4 show the recommended PCB layout, make sure the space under the chip should keep free from planes, traces, pads and via. To enhance the robustness of a design, the user may also include resistors (50–300 Ω) in series with the inputs and outputs if the system is excessively noisy. The series resistors also improve the system reliability such as latch-up immunity.

The typical output impedance of an isolator driver channel is approximately 50 Ω , $\pm 40\%$. When driving loads where transmission line effects will be a factor, output pins should be appropriately terminated with controlled impedance PCB traces.

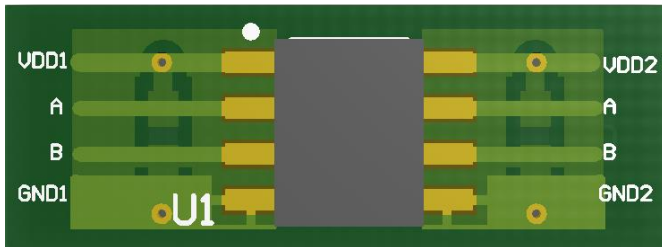

Figure 5.1 Recommended PCB Layout — Top Layer

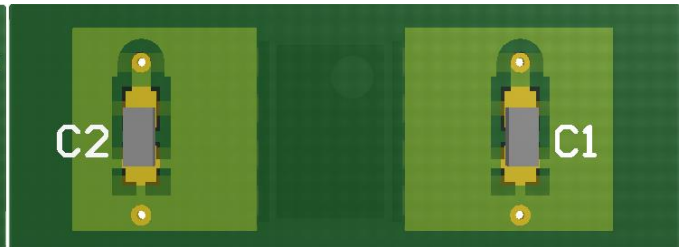

Figure 5.2 Recommended PCB Layout — Bottom Layer

6.0 PACKAGE INFORMATION

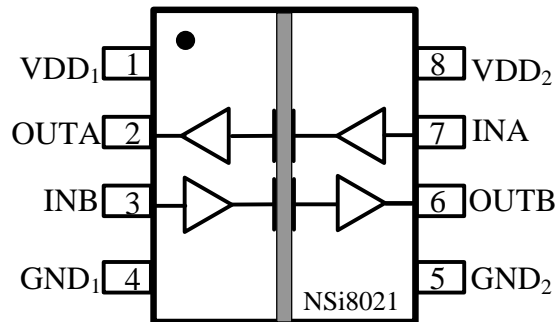

Figure 6.2 NSI8021N Package

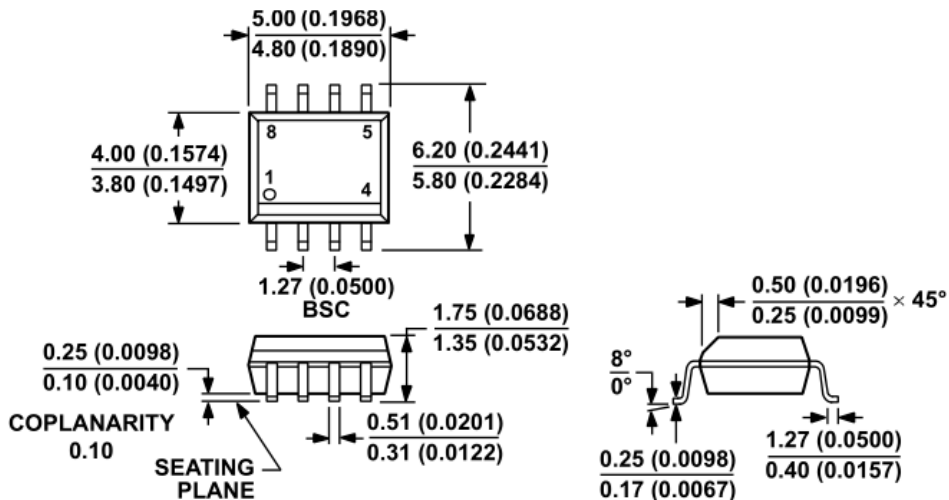
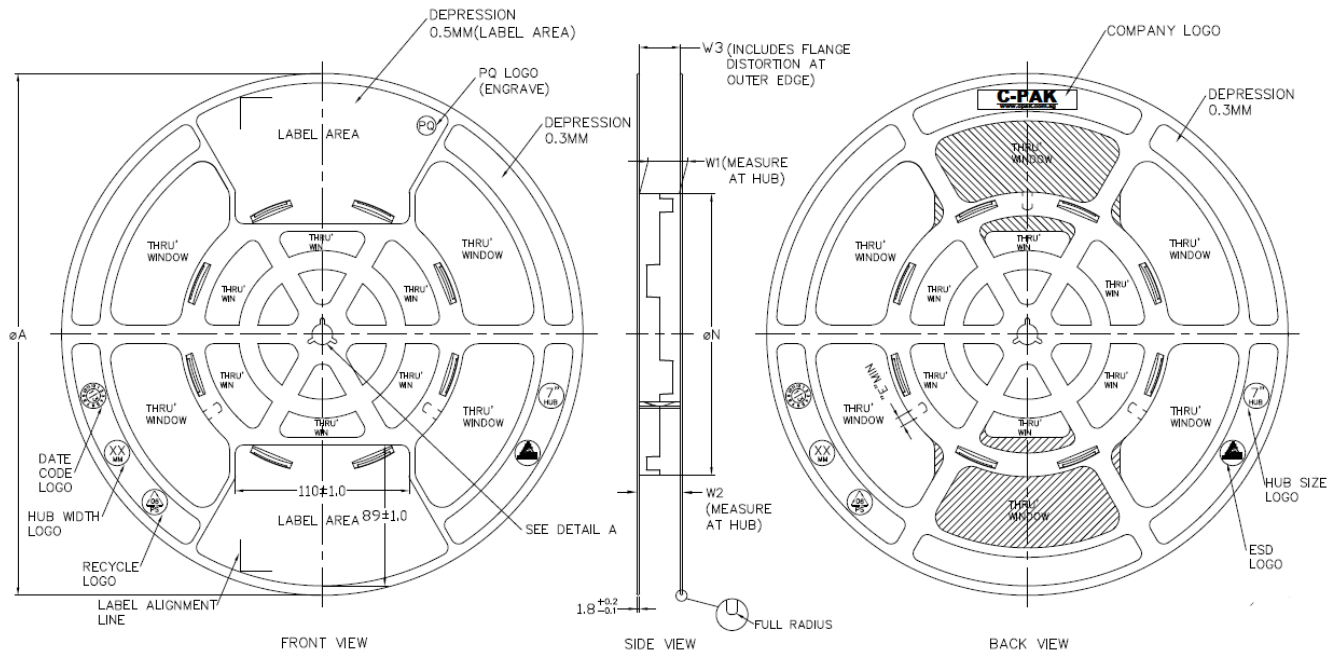

Figure 6.3 SOIC8 Package Shape and Dimension in millimeters (inches)

Table 6.1 NSI8021N Pin Configuration and Description

NSI8021N PIN NO.	SYMBOL	FUNCTION
1	VDD1	Power Supply for Isolator Side 1
2	OUTA	Logic Output A
3	INB	Logic Input B
4	GND1	Ground 1, the ground reference for Isolator Side 1
5	GND2	Ground 2, the ground reference for Isolator Side 2
6	OUTB	Logic Output B
7	INA	Logic Input A
8	VDD2	Power Supply for Isolator Side 2

7.0 TAPE AND REEL INFORMATION



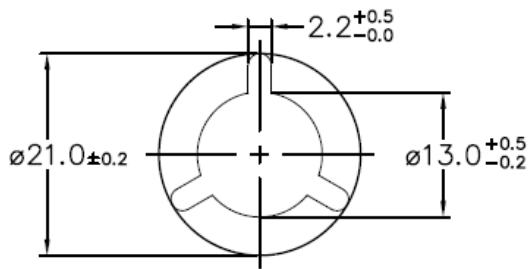

ARBOR HOLE
DETAIL A
SCALE : 3:1

PRODUCT SPECIFICATION						
TAPE WIDTH	∅A ±2.0	∅N ±2.0	W1	W2 (MAX)	W3	E (MIN)
08MM	330	178	8.4 ± 1.5 -0.0	14.4	SHALL ACCOMMODATE TAPE WIDTH WITHOUT INTERFERENCE	5.5
12MM	330	178	12.4 ± 2.0 -0.0	18.4		5.5
16MM	330	178	16.4 ± 2.0 -0.0	22.4		5.5
24MM	330	178	24.4 ± 2.0 -0.0	30.4		5.5
32MM	330	178	32.4 ± 2.0 -0.0	38.4		5.5

SURFACE RESISTIVITY			
LEGEND	SR RANGE	TYPE	COLOUR
A	BELOW 10 ¹²	ANTISTATIC	ALL TYPES
B	10 ⁹ TO 10 ¹¹	STATIC DISSIPATIVE	BLACK ONLY
C	10 ⁹ & BELOW 10 ⁹	CONDUCTIVE (GENERIC)	BLACK ONLY
E	10 ⁹ TO 10 ¹¹	ANTISTATIC (COATED)	ALL TYPES

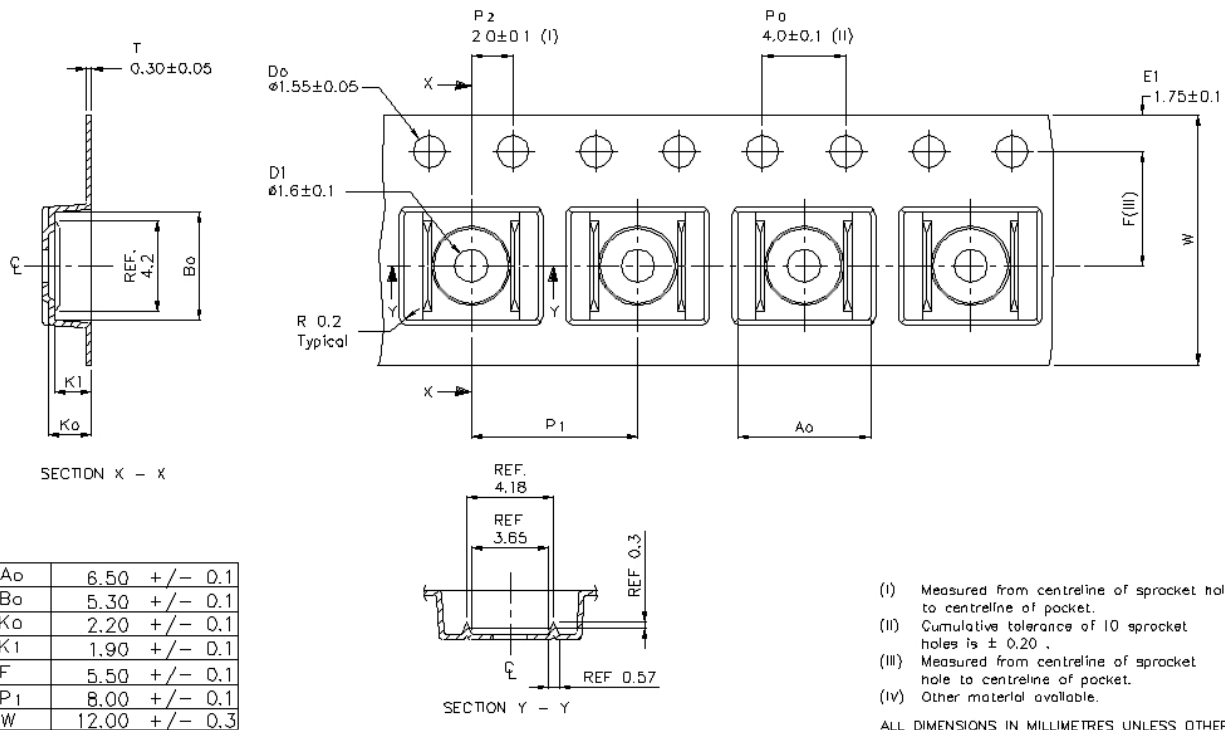

Figure 7.1 Tape and Reel Information of SOIC8

8.0 ORDER INFORMATION

Part Number Rule:

<i>Part No.</i>	<i>Isolation Rating(kV)</i>	<i>Number of side 1 inputs</i>	<i>Number of side 2 inputs</i>	<i>Max Data Rate (Mbps)</i>	<i>Default Output State</i>	<i>Temperature</i>	<i>SPQ</i>	<i>Package</i>
NSI8021N1-DSPR	3	1	1	10	High	-40 to 125°C	2500	SOIC8
NOTE: All packages are RoHS-compliant with peak reflow temperatures of 260 °C according to the JEDEC industry standard classifications and peak solder temperatures.								

9.0 REVISION HISTORY

Revision	Description	Date
1.0	Original	2019/10/10
1.1	Update Format	2020/05/03