

NSP (Flash) Data Sheet

The information described in this document is the exclusive intellectual property of Nuvoton Technology Corporation and shall not be reproduced without permission from Nuvoton.

Nuvoton is providing this document only for reference purposes of *NSP* based system design. Nuvoton assumes no responsibility for errors or omissions.

All data and specifications are subject to change without notice.

For additional information or questions, please contact: Nuvoton Technology Corporation.

www.nuvoton.com

Table of Contents

1.	General Description.....	3
2.	Features.....	3
3.	Pin Description	4
4.	Electrical Characteristics	4
4.1	Absolute Maximum Ratings	4
4.2	D.C. Characteristics	5
4.3	A.C. Characteristics	5
4.4	Output Power	5
5.	Typical Application Circuit.....	6
5.1	Voice Prompt Application By NSP SOP8:	6
5.2	Voice Prompt Application By NSP SOP14:	6
5.3	Voice Prompt Application With N55PA01 PA:.....	7
6.	Package Information.....	8
6.1	Pin Assignment	8
6.2	Package Dimension	9
7.	Ordering Information.....	11
8.	Revision History	11

1. General Description

NSP series is an advanced 1-ch Voice IC with embedded Flash and equips new algorithm to implement Voice Prompt applications with high level of sound quality. NSP series provide SOP8 and SOP14 with 2 I/Os protocol or UART to communicate with host MCU.

The NSP family contains following chips built-in different size of embedded Flash, shown as below:

Part No.	Package	Duration (S)		V _{DD} (V)	LVR (V)	Audio	ISP	REG Pin	Interface
		8KHz	12KHz			PWM			
NSP040A	SOP8	60	40	2.0~5.5	1.9	13-bit	No	Yes	1-wire, 2-wire
NSP082A	SOP8	94	63	2.0~5.5	1.9	13-bit	Yes	Yes	1-wire, 2-wire
NSP172A	SOP8	155	103	2.0~5.5	1.9	13-bit	Yes	Yes	1-wire, 2-wire
NSP341A	SOP8	337	225	2.0~5.5	1.9	13-bit	Yes	Yes	1-wire, 2-wire
NSP342A	SOP8	337	225	2.0~5.5	1.9	13-bit	Yes	Yes	1-wire, 2-wire
NSP481A	SOP8	458	305	2.0~5.5	1.9	13-bit	Yes	Yes	1-wire, 2-wire
NSP650B	SOP14	701	467	2.0~5.5	1.9	13-bit	Yes	Yes	1-wire, 2-wire, UART
NSP960B	SOP14	944	629	2.0~5.5	1.9	13-bit	Yes	Yes	1-wire, 2-wire, UART
NSP2K0B	SOP14	1896	1264	2.0~5.5	1.9	13-bit	Yes	Yes	1-wire, 2-wire, UART

2. Features

- Operating voltage: 2.0~5.5V
- Oscillator: builds in internal Rosc (TRIM)
 - Frequency deviation: +/-1.5%
- Audio output: 13-bit PWM
- Voice channel: 1-ch Voice
- Provide ISP (In System Program) to update content from Host MCU
- Interface with MCU: 1-wire, 2-wire, UART (only support on NSP650B/960B/2K0B)
- Low Voltage Reset (LVR)
- Flash Data Retention: 10-Year
- Flash Program/Erase Cycling Endurance: 10K
- Package form: SOP8, SOP14
- Package is Halogen-free, RoHS-compliant and TSCA-compliant

3. PIN Description

Pin Name	I/O	Function
BP00 BP01 BP12 BP13 BP17 BP20	I/O	<ul style="list-style-type: none"> ● General input/output pins. ● Each pin can be set as Input or Output individually ● For input pin, it can be set as pull-high ● BP00, BP01 share with ICPCLK and ICPDATA ● BP12, BP13, BP17, BP20 support on NSP650B/960B/2K0B
VDD	Power	Positive power supply
REG	Power	Internal regulator, 0.1uF capacitor is needed
VSS	Power	Negative power supply
PWM+	O	PWM driver positive output to drive speaker directly
PWM-	O	PWM driver negative output to drive speaker directly
VDD_SPK	Power	Positive power supply for speaker driver
VSS_SPK	Power	Negative power supply for speaker driver
/RESET	I	IC reset input, low active. No support on NSP040A

Note 1 : Program pin includes BP00 (ICPCLK), BP01(ICPDATA), /RESET, VDD, VSS (Does not contain NSP040A)

Note 2 : NSP040A Program pin includes BP00 (ICPCLK), BP01 (ICPDATA), PWM-, VDD, VSS

4. Electrical Characteristics

4.1 Absolute Maximum Ratings

Parameter	Symbol	Conditions	Rated Value	Unit
Input Voltage	VIN	All Inputs	VSS -0.3 to VDD +0.3	V
Storage Temp.	TSTG	-	-55 to +150	°C
Operating Temp.	TOPR	-	-20 to +85	°C

Note: Exposure to conditions beyond those listed under the Absolute Maximum Ratings table may adversely affect the life and reliability of the device.

4.2 D.C. Characteristics

(VDD – VSS = 4.5V, TA = 25° C, No Load unless otherwise specified)

Parameter	Sym	Conditions	Min	Typ	Max	Unit
Operating Voltage	V _{DD}		2.0	-	5.5	V
Operating Current	I _{OP1}	No load	-	4	6	mA
Standby Current (STOP)	I _{DD1}	No load	-	1	2	μA
Input Low Voltage	V _{IL}	All input pins	V _{SS}	-	0.3 V _{DD}	V
Input High Voltage	V _{IH}	All input pins	0.7 V _{DD}	-	V _{DD}	V
Pull High resistor BP0, BP1	R _{PH}	V _{DD} = 4.5V	90K	150K	210K	Ω
Output Current BP0, BP1	I _{OL}	V _{DD} = 3V, V _{OUT} = 0.4V	8	12	-	mA
	I _{OH}	V _{DD} = 3V, V _{OUT} = 2.6V	-4	-6	-	mA
	I _{OL}	V _{DD} = 4.5V, V _{OUT} = 1.0V	-	25	-	mA
	I _{OH}	V _{DD} = 4.5V, V _{OUT} = 3.5V	-	-12	-	mA

4.3 A.C. Characteristics

(VDD = 4.5V, TA = 25°C, No Load unless otherwise specified)

Parameter	Sym	Conditions	Min	Typ	Max	Unit
Frequency Deviation by Voltage Drop	ΔF/F	(F _{max} – F _{min})/F _{min} @VDD: 2.4 ~ 5.5V	-	2	-	%

4.4 Output Power

(Frequency Input = 1KHz Sine Wave, RL = 8Ω, THD+N ≤ 1%)

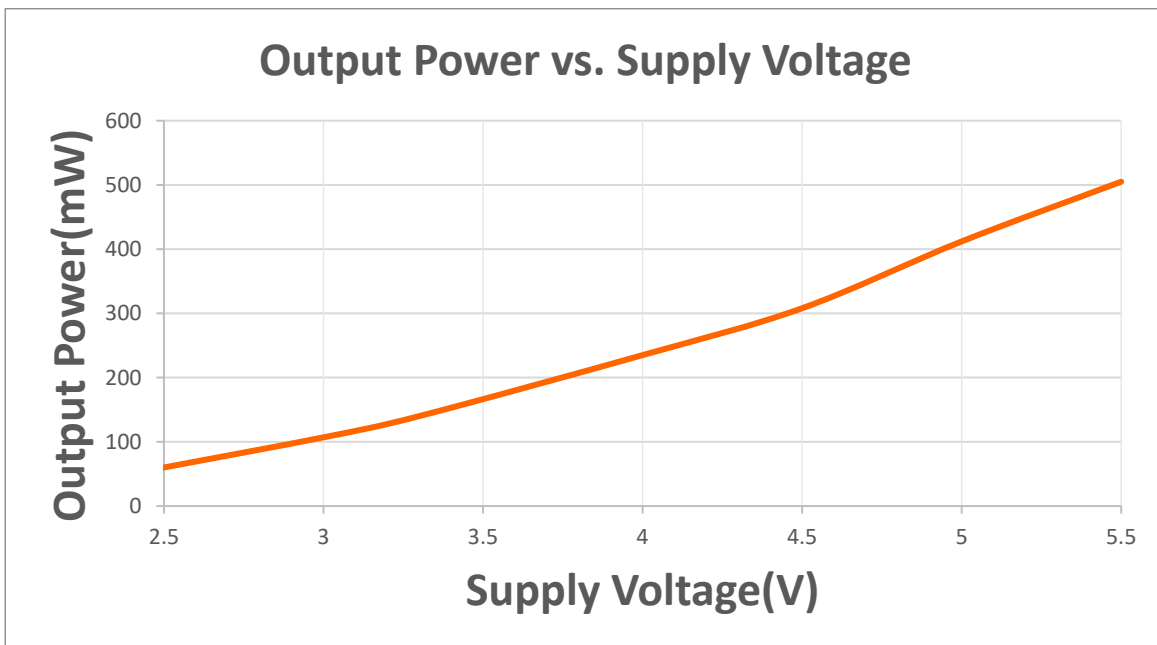

5. Typical Application Circuit

5.1 Voice Prompt Application by NSP SOP8:

NSP040A/082A/172A/341A/342A/481A

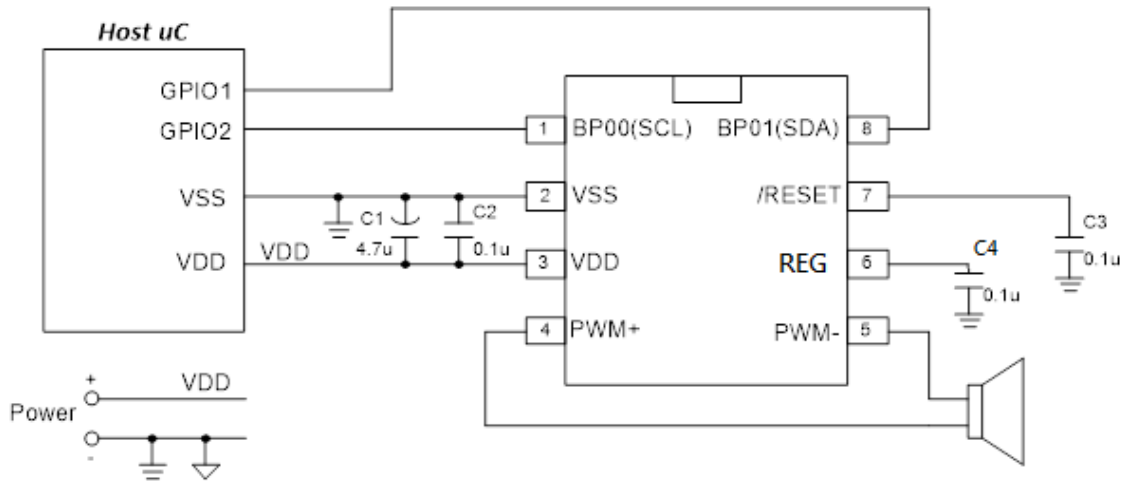

Note1: Pin7 in NSP040A is NC

Note2: C1 and C2 need to be close to the NSP chip layout

Note3: Pin6 REG with 0.1uF is necessary for internal regulator. It is suitable for the system with high power noise.

5.2 Voice Prompt Application by NSP SOP14:

NSP650B/960B/2K0B

a. Connect to Host uC by SCL/SDA:

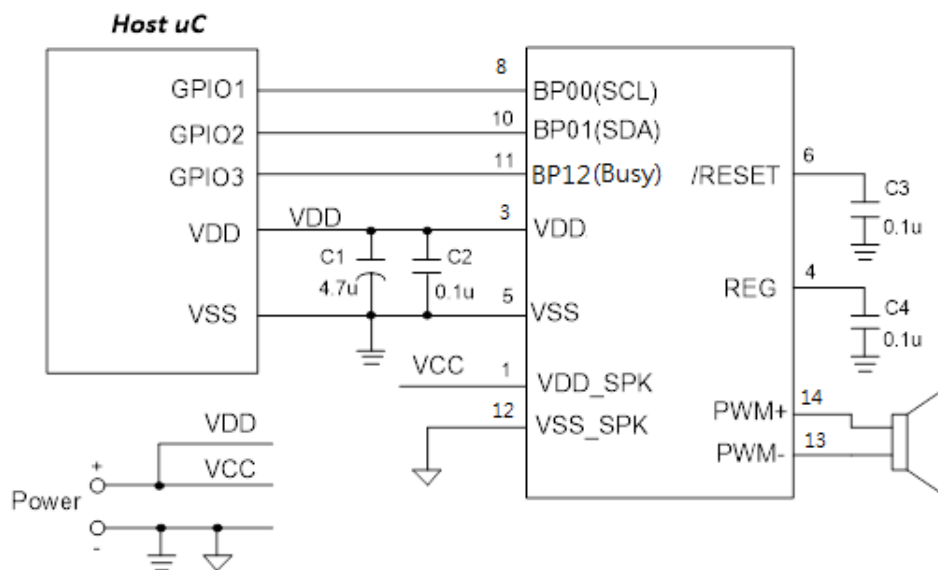

b. Connect to Host uC by UART_TX/RX:

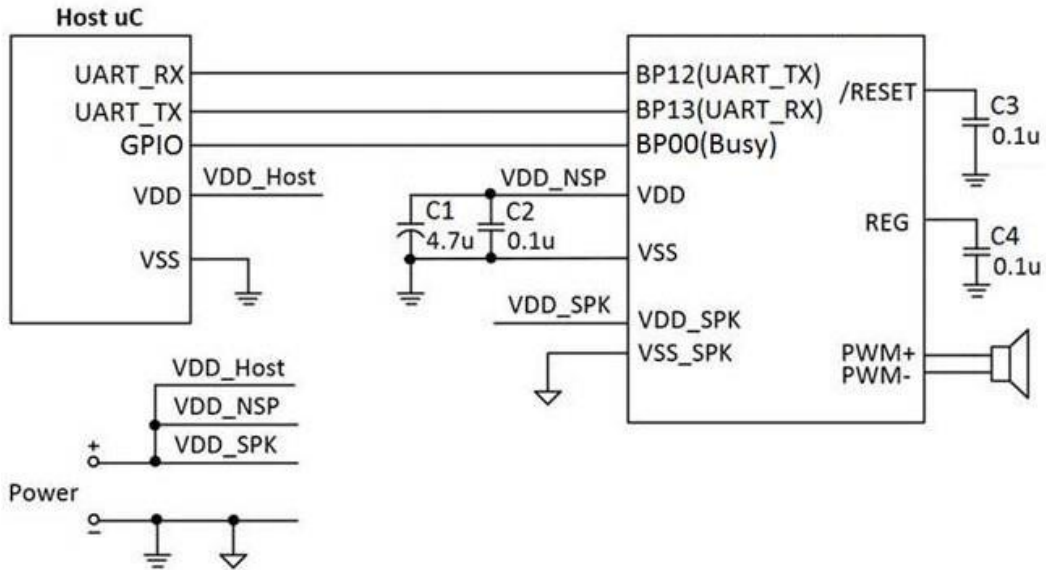

Note: C1 and C2 need to be close to the NSP chip layout.

5.3 Voice Prompt Application with N55PA01 PA:

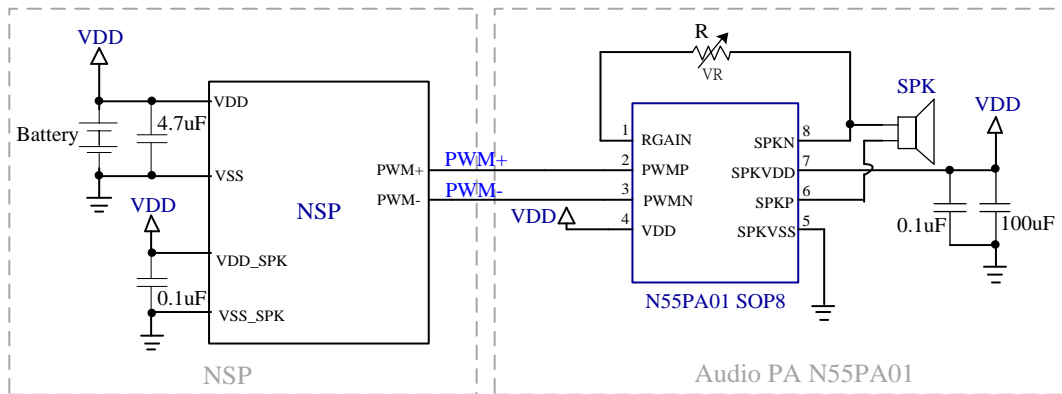

6. Package Information

6.1 Pin Assignment

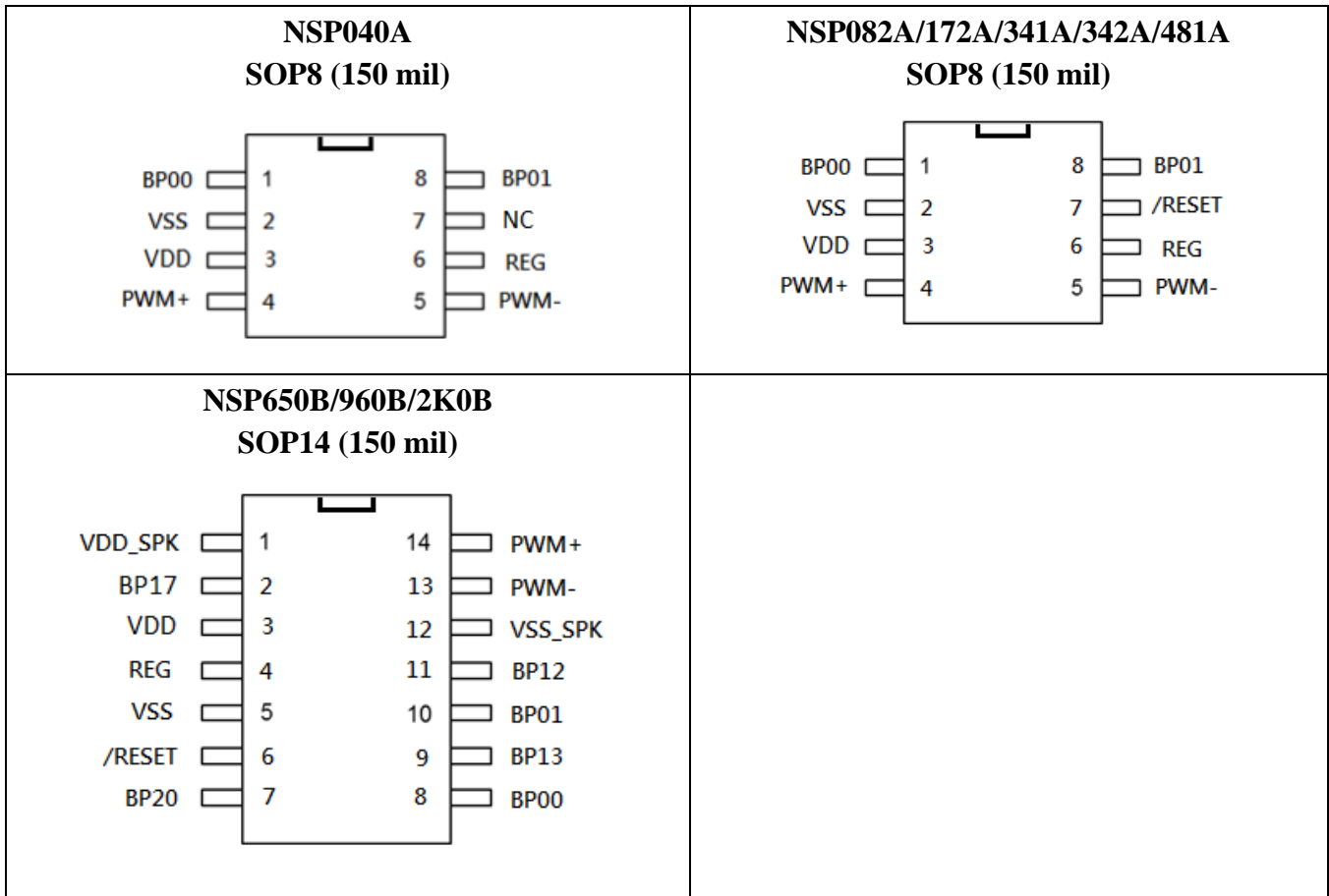

6.2 Package Dimension

SOP8, 150 mil

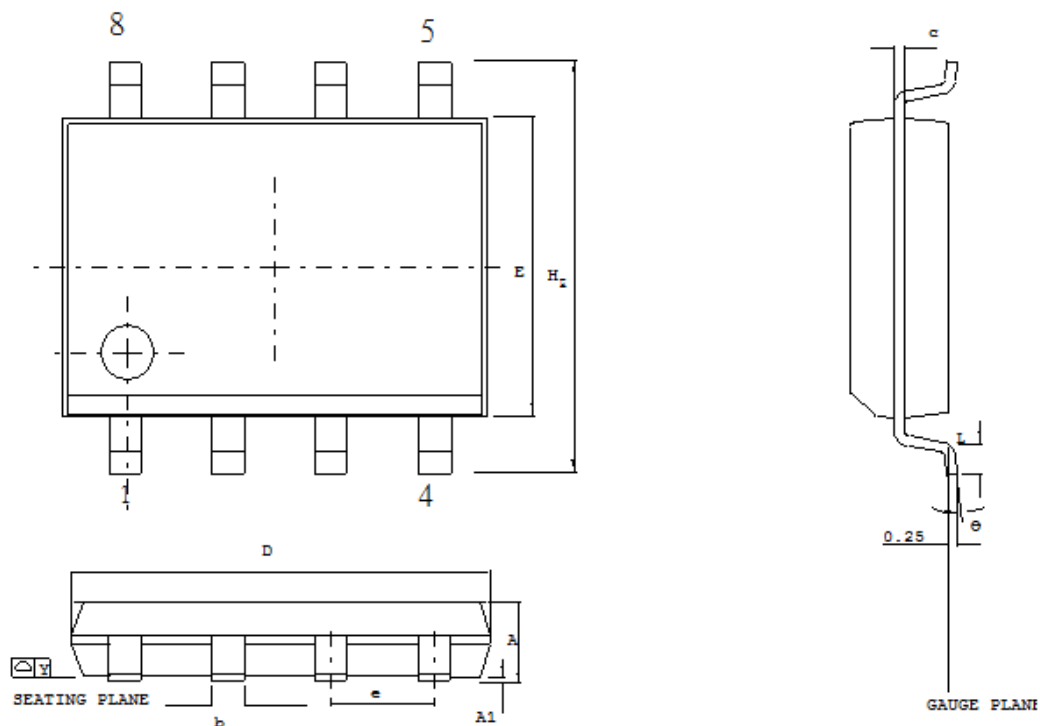

Control dimensions are in millimeters .

SYMBOL	DIMENSION IN MM		DIMENSION IN INCH	
	MIN.	MAX.	MIN.	MAX.
A	1.35	1.75	0.053	0.069
A1	0.10	0.25	0.004	0.010
b	0.33	0.51	0.013	0.020
c	0.19	0.25	0.008	0.010
E	3.80	4.00	0.150	0.157
D	4.80	5.00	0.188	0.196
e	1.27 BSC		0.050 BSC	
H1	5.80	6.20	0.228	0.244
Y	—		—	
L	0.40	1.27	0.016	0.050
θ	0	10	0	10

SOP14, 150 mil

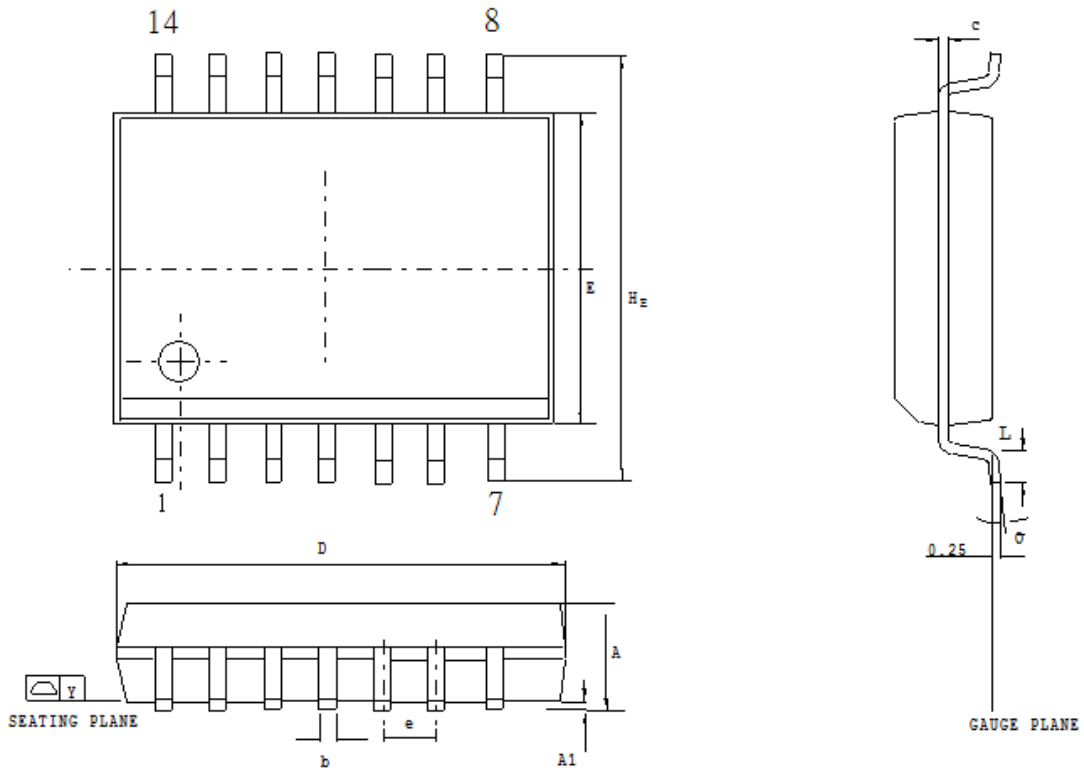

Control demensions are in milimeters .

SYMBOL	DIMENSION IN MM		DIMENSION IN INCH	
	MIN.	MAX.	MIN.	MAX.
A	1.35	1.75	0.053	0.069
A1	0.10	0.25	0.004	0.010
b	0.33	0.51	0.013	0.020
c	0.19	0.25	0.008	0.010
E	3.80	4.00	0.150	0.157
D	8.55	8.75	0.337	0.344
e	1.27 BSC		0.050 BSC	
HE	5.80	6.20	0.228	0.244
Y	—	0.10	—	0.004
L	0.40	1.27	0.016	0.050
Φ	0	8	0	8

7. Ordering Information

Part No.	Shape	Package Type	Remark
NSP040A NSP082A NSP172A NSP341A NSP342A NSP481A	E: Tube T: Tape&Reel	SOP8 (150mil)	Blank chip
NSP650B NSP960B NSP2K0B	E: Tube T: Tape&Reel	SOP14 (150mil)	Blank chip

8. Revision History

Version	Date	Substantial Changes	Page
1.0	Sep.2018	Initial Release	All
1.1	Sep.2018	Update Product Selection Guide	3
1.2	Nov.2018	Add NSP340A, SOP8 package	10-15
2.0	Dec.2018	Update SOP8 as 2 I/O Add NSP080A/170A SOP8 package	All
3.0	Jan.2019	Remove SOP20, LQFP48 and modify Features, Application Circuit for Voice Prompt Application	All
4.0	May.2019	Update Pin Description, Application Circuit, Ordering Information	5,6,8,12
5.0	Jul.2019	Add part no. NSP081A, NSP171A Update AP circuit	3,9,12 6,7
5.1	Aug.2019	Update duration on Selection Guide	3
6.0	Oct.2019	Add NSP341A/481A/650A/960A and NSP480B/650B/960B	All
6.1	Nov.2019	Revise operation temperature as -20 to 85 degree C	4
6.2	Nov.2019	Update NSP480B/650B/960B SOP14 Pin Assignment	12
6.3	Dec.2019	Skip NSP650A/960A Update NSP480B/650B/960B SOP14 Pin Assignment	11
6.4	Dec.2019	Correct NSP081A/171A/341A/481A Pin Assignment Remove the section of MCU Protocol and Command List	8
7.0	May.2020	Add UART Application Circuit on NSP480B/650B/960B	7
8.0	Sep. 2020	Update NSP341A, NSP481A SOP8 Pin Assignment	6, 9
9.0	Dec.2020	Add NSP082A, NSP172A Revise NSP + PA Application Circuit with N55PA01 Add information about Flash Data Retention and Life Cycle	All
10.0	Mar. 2021	Remove NSP080A/170A Add NSP040A	All

10.1	Aug, 2021	Update features and Selection Guide Add note3 for the NSP040A/082A/172A/341A/481A Application Circuit	3 6
11	Feb, 2022	Remove NSP081A/171A/340A, NSP080B/170B/340B/480B Update NSP082A/172A ordering part number Add NSP2K0B	All
11.1	May, 2022	Add NSP342	All

Important Notice

Nuvoton Products are neither intended nor warranted for usage in systems or equipment, any malfunction or failure of which may cause loss of human life, bodily injury or severe property damage. Such applications are deemed, “Insecure Usage”.

Insecure usage includes, but is not limited to: equipment for surgical implementation, atomic energy control instruments, airplane or spaceship instruments, the control or operation of dynamic, brake or safety systems designed for vehicular use, traffic signal instruments, all types of safety devices, and other applications intended to support or sustain life.

All Insecure Usage shall be made at customer’s risk, and in the event that third parties lay claims to Nuvoton as a result of customer’s Insecure Usage, customer shall indemnify the damages and liabilities thus incurred by Nuvoton.

*Please note that all data and specifications are subject to change without notice.
All the trademarks of products and companies mentioned in this datasheet belong to their respective owners.*