

## Product Overview

The NSREF30xx is a family of low power, low dropout, precision bandgap references. These designs are available in 3-pin SOT23 package. The NSREF30xx's small size and low power consumption makes them ideal for use in battery-powered systems where there can be wide variations in supply voltage and a need to minimize power dissipation. The NSREF30xx does not require an output compensation capacitor, yet is stable with capacitive loads and can sink or source up to  $\pm 10$  mA of output current. Unloaded, the NSREF30xx can operate on supplies down to 1 mV above the output voltage. All models are specified over the temperature range of  $-40^{\circ}\text{C}$  to  $+125^{\circ}\text{C}$ .

## Key Features

- Excellent Specified Drift Performance:  
35 ppm/ $^{\circ}\text{C}$  (Maximum) from  $-40^{\circ}\text{C}$  to  $+125^{\circ}\text{C}$
- Output Noise (0.1 to 10Hz): 22 $\mu\text{Vpp}$  of NSREF3025
- High Output Current:  $\pm 10$  mA
- High Accuracy: 0.2% Maximum
- Do Not Require a Load Capacitor to Be Stable
- Low Dropout: 1mV

## Applications

- Data Acquisition Systems
- Medical Equipment
- Hand-Held Test Equipment

## Device Information

Part Number	Package	Body Size
NSREF3012-DSTR	SOT23-3L	2.9 mm $\times$ 1.3 mm
NSREF3020-DSTR		
NSREF3025-DSTR		
NSREF3030-DSTR		
NSREF3033-DSTR		
NSREF3040-DSTR		

## Functional Block Diagram

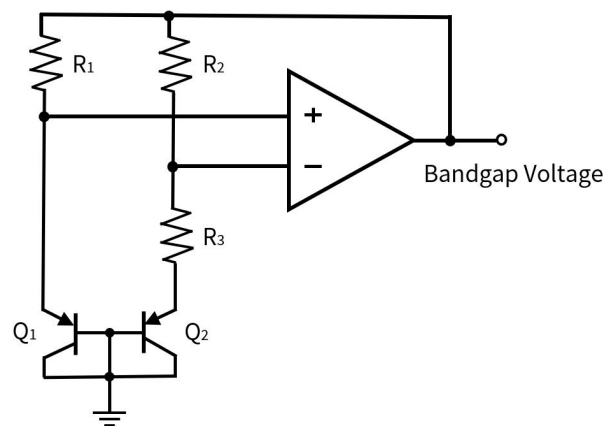

Figure 1 NSREF30xx Functional Block Diagram

## INDEX

1. PIN CONFIGURATION AND FUNCTIONS .....	3
2. ABSOLUTE MAXIMUM RATINGS .....	4
3. ESD RATINGS .....	4
4. RECOMMENDED OPERATING CONDITIONS .....	4
5. THERMAL INFORMATION .....	4
6. ELECTRICAL CHARACTERISTICS .....	5
7. TYPICAL PERFORMANCE CHARACTERISTICS .....	7
8. APPLICATION INFORMATION .....	11
8.1. TEMPERATURE COEFFICIENT .....	11
8.2. LONG-TERM STABILITY .....	11
8.3. NOISE PERFORMANCE .....	12
8.4. TYPICAL VOLTAGE REFERENCE CONNECTION .....	12
8.4.1. INPUT CAPACITORS .....	12
8.4.2. LOAD CAPACITORS .....	12
8.5. LAYOUT GUIDELINES .....	12
9. PACKAGE INFORMATION .....	13
10. ORDERING INFORMATION .....	14
11. DOCUMENTATION SUPPORT .....	14
12. TAPE AND REEL INFORMATION .....	15
13. REVISION HISTORY .....	16

## 1. Pin Configuration and Functions

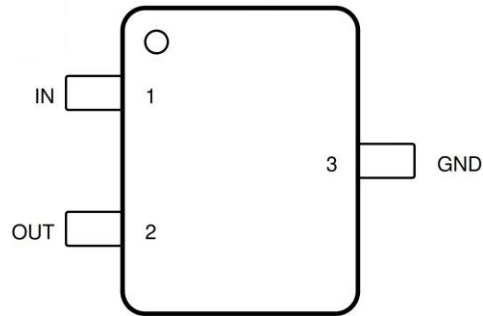

Figure 1.1 NSREF30xx SOT23-3L Package Top View

Table 1.1 NSREF30xx Pin Configuration and Description

<i><b>PIN No.</b></i>	<i><b>Symbol</b></i>	<i><b>Function</b></i>
1	IN	Input supply voltage
2	OUT	Reference output voltage
3	GND	Ground

## 2. Absolute Maximum Ratings

Parameters	Symbol	Min	Typ	Max	Unit
Input supply voltage	$V_{IN}$			6.5	V
Storage temperature	$T_{stg}$	-65		150	°C
Ambient temperature	$T_A$	-40		125	°C
Junction temperature	$T_J$	-40		150	°C

## 3. ESD Ratings

Ratings		Value	Unit
Electrostatic discharge	Human-body model (HBM), per AEC-Q100-002-RevE ● All pins	±8000	V
	Charged-device model (CDM), per AEC-Q100-011-RevD ● All pins	±2000	V

## 4. Recommended Operating Conditions

Parameters	Symbol	Min	Typ	Max	Unit	Comments
Input voltage	$V_{IN}$	1.8		5.5	V	NSREF3012 Only
		$V_{OUT} + 0.05$		5.5		Except NSREF3012
Load current	$I_{LOAD}$	-10		10	mA	
Operating temperature	$T_A$	-40		125	°C	

## 5. Thermal Information

Parameters	Symbol	SOT23-3L	Unit
Junction-to-ambient thermal resistance	$\theta_{JA}$	298	°C/W
Junction-to-case(top) thermal resistance	$\theta_{JC (top)}$	97	°C/W
Junction-to-board thermal resistance	$\theta_{JB}$	72	°C/W

## 6. Electrical Characteristics

$T_A = 25^\circ\text{C}$ ,  $V_{IN} = 5\text{V}$  and  $I_{LAOD} = 0\text{mA}$  (Unless otherwise noted) <sup>1</sup>

Parameters	Symbol	Condition	Min	Typ	Max	Unit
<b>NSREF3012 (1.25V)</b>						
Output voltage	$V_{OUT}$		1.2475	1.25	1.2525	V
Quiescent current	$I_Q$			135	165	uA
		$T_A = -40^\circ\text{C}$ to $+125^\circ\text{C}$			170	
Output voltage noise	$e_{n,p-p}$	$f = 0.1\text{Hz}$ to $10\text{Hz}$		9		$\mu\text{V}_{pp}$
Line regulation		$1.8 \leq V_{IN} \leq 5.5\text{V}$		30	90	ppm/V
Turn-on settling time		to 0.1% with $C_L = 0$		100		us
<b>NSREF3020 (2.048V)</b>						
Output voltage	$V_{OUT}$		2.044	2.048	2.052	V
Quiescent current	$I_Q$			140	165	uA
		$T_A = -40^\circ\text{C}$ to $+125^\circ\text{C}$			170	
Output voltage noise	$e_{n,p-p}$	$f = 0.1\text{Hz}$ to $10\text{Hz}$		20		$\mu\text{V}_{pp}$
Line regulation		$V_{OUT} + 0.05\text{V} \leq V_{IN} \leq 5.5\text{V}$		25	85	ppm/V
Turn-on settling time		to 0.1% with $C_L = 0$		250		us
<b>NSREF3025 (2.5V)</b>						
Output voltage	$V_{OUT}$		2.495	2.5	2.505	V
Quiescent current	$I_Q$			140	165	uA
		$T_A = -40^\circ\text{C}$ to $+125^\circ\text{C}$			170	
Output voltage noise	$e_{n,p-p}$	$f = 0.1\text{Hz}$ to $10\text{Hz}$		22		$\mu\text{V}_{pp}$
Line regulation		$V_{OUT} + 0.05\text{V} \leq V_{IN} \leq 5.5\text{V}$		15	85	ppm/V
Turn-on settling time		to 0.1% with $C_L = 0$		380		us
<b>NSREF3030 (3.0V)</b>						
Output voltage	$V_{OUT}$		2.994	3	3.006	V
Quiescent current	$I_Q$			145	170	uA
		$T_A = -40^\circ\text{C}$ to $+125^\circ\text{C}$			175	
Output voltage noise	$e_{n,p-p}$	$f = 0.1\text{Hz}$ to $10\text{Hz}$		28		$\mu\text{V}_{pp}$
Line regulation		$V_{OUT} + 0.05\text{V} \leq V_{IN} \leq 5.5\text{V}$		15	90	ppm/V
Turn-on settling time		to 0.1% with $C_L = 0\mu\text{F}$		450		us

## Electrical Characteristics(continued)

$T_A = 25^\circ\text{C}$ ,  $V_{IN} = 5\text{V}$  and  $I_{LOAD} = 0\text{mA}$  (Unless otherwise noted)<sup>1</sup>

Parameters	Symbol	Condition	Min	Typ	Max	Unit
<b>NSREF3033 (3.3V)</b>						
Output voltage	$V_{OUT}$		3.294	3.3	3.306	V
Quiescent current	$I_Q$			145	170	uA
		$T_A = -40^\circ\text{C}$ to $+125^\circ\text{C}$			175	
Output voltage noise	$e_{n\text{ p-p}}$	$f = 0.1\text{Hz}$ to $10\text{Hz}$		31		$\mu\text{V}_{pp}$
Line regulation		$V_{OUT} + 0.05\text{V} \leq V_{IN} \leq 5.5\text{V}$		25	100	ppm/V
Turn-on settling time		To 0.1% with $C_L = 0$		550		us
<b>NSREF3040 (4.096V)</b>						
Output voltage	$V_{OUT}$		4.088	4.096	4.104	V
Quiescent current	$I_Q$			145	175	uA
		$T_A = -40^\circ\text{C}$ to $+125^\circ\text{C}$			175	
Output voltage noise	$e_{n\text{ p-p}}$	$f = 0.1\text{Hz}$ to $10\text{Hz}$		33		$\mu\text{V}_{pp}$
Line regulation		$V_{OUT} + 0.05\text{V} \leq V_{IN} \leq 5.5\text{V}$		50	150	ppm/V
Turn-on settling time		To 0.1% with $C_L = 0$		680		us
<b>NSREF30xx (NSREF3012, NSREF3020, NSREF3025, NSREF3030, NSREF3033, NSREF3040)</b>						
Input supply voltage	$V_{IN}$	NSREF3012	1.8		5.5	V
		Except NSREF3012	$V_{OUT} + 0.05$		5.5	
Temperature drift <sup>2</sup>	$d_{V_{OUT}}/d_T$	$T_A = -40^\circ\text{C}$ to $125^\circ\text{C}$		10	35	ppm/ $^\circ\text{C}$
Thermal hysteresis		First cycle, $T_A$ cycled from $25^\circ\text{C}$ to $125^\circ\text{C}$ to $-40^\circ\text{C}$ to $25^\circ\text{C}$		100		ppm
Load regulation	$\Delta V_{O(\Delta I_L)}$	$I_L = 0\text{mA}$ to $10\text{mA}$ , $V_{IN} = V_{OUT} + 0.25\text{V}$ <sup>3</sup>		5	10	uV/mA
		$I_L = -10\text{mA}$ to $0\text{mA}$ , $V_{IN} = V_{OUT} + 0.1\text{V}$ <sup>3</sup>		25	50	
Output current	$I_{LOAD}$	Guaranteed by Load Regulation	-10		+10	mA
Dropout voltage	$V_{IN} - V_{OUT}$			1		mV
Short-circuit current	$I_{SC}$	Sourcing		40		mA
		Sinking		55		
Long-term stability		0 to 1000h at $35^\circ\text{C}$		100		ppm
		0 to 2000h at $35^\circ\text{C}$		130		ppm

<sup>1</sup>NSREF30xx series are 100% production tested at  $T_A = +25^\circ\text{C}$  and are guaranteed by characterization for  $T_A = T_{MIN}$  to  $T_{MAX}$  as specified.

<sup>2</sup>Box Method used to determine temperature drift.

<sup>3</sup>Minimum supply voltage for the NSREF3012 is 1.8V.

## 7. Typical Performance Characteristics

$T_A = 25^\circ\text{C}$ ,  $V_{IN} = 5\text{V}$  and  $I_{LAOD} = 0\text{mA}$  (Unless otherwise noted)

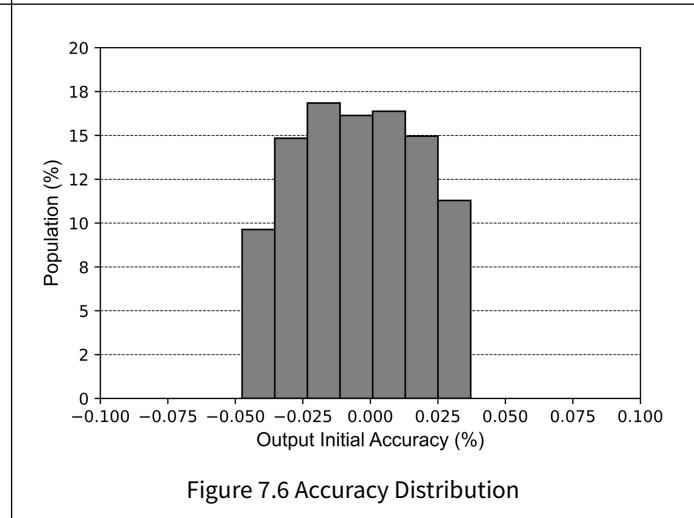
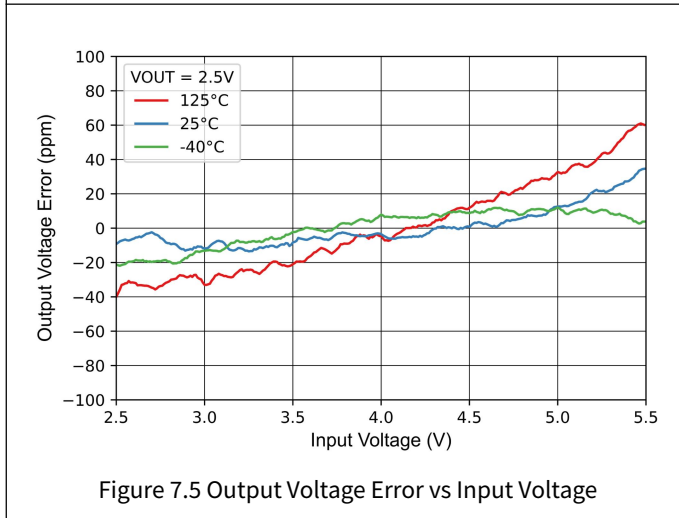
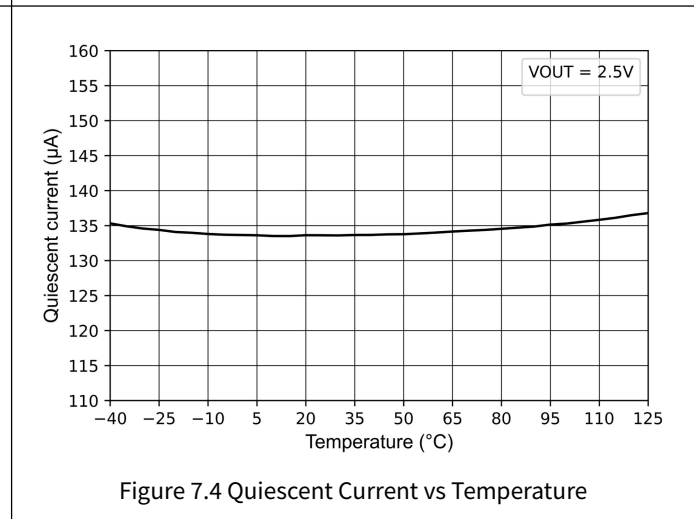
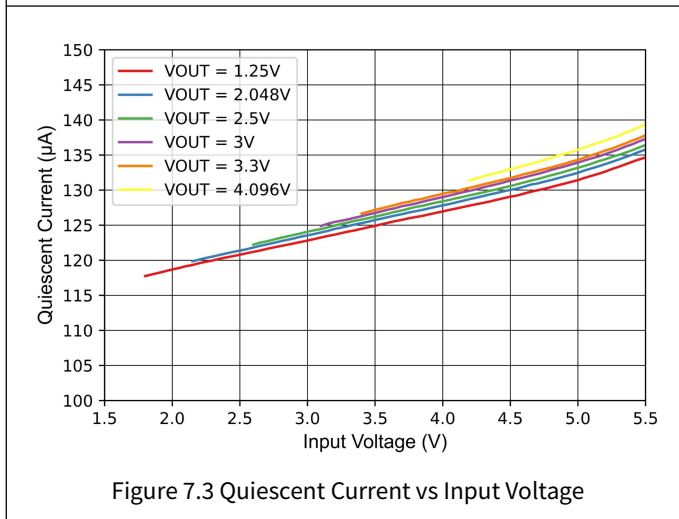
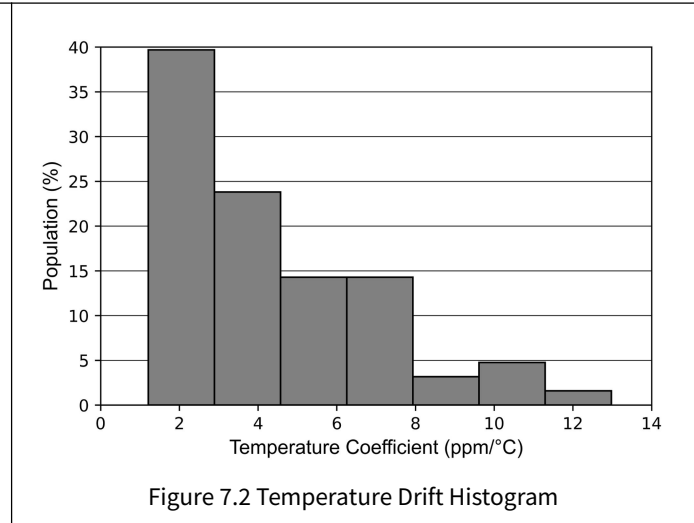
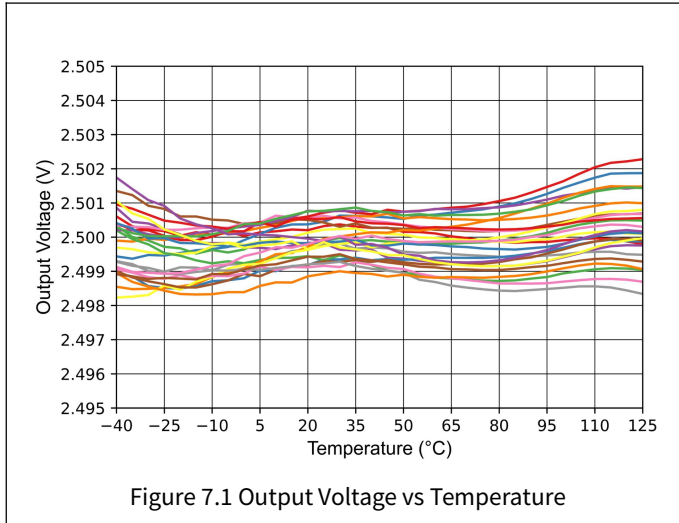

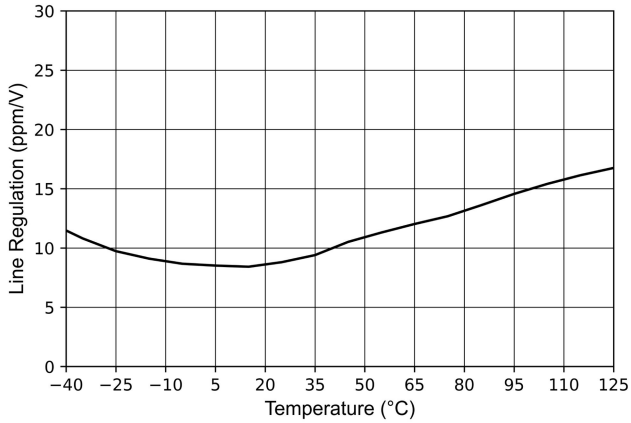

Figure 7.7 Line Regulation vs Temperature

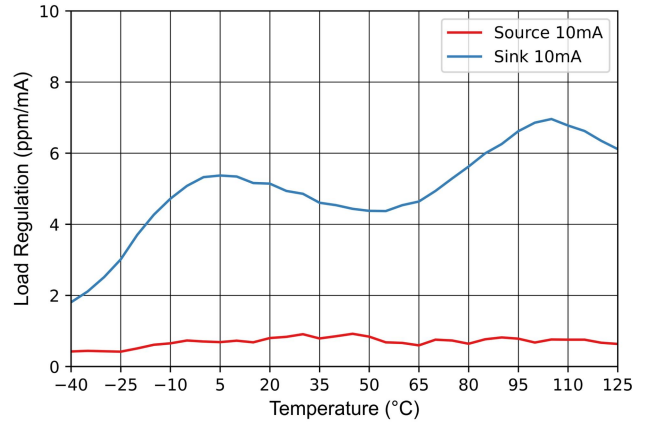

Figure 7.8 Load Regulation vs Temperature

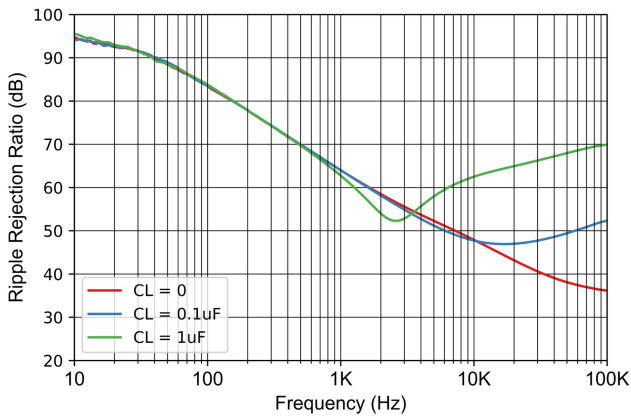

Figure 7.9 Ripple Rejection Ratio vs Frequency

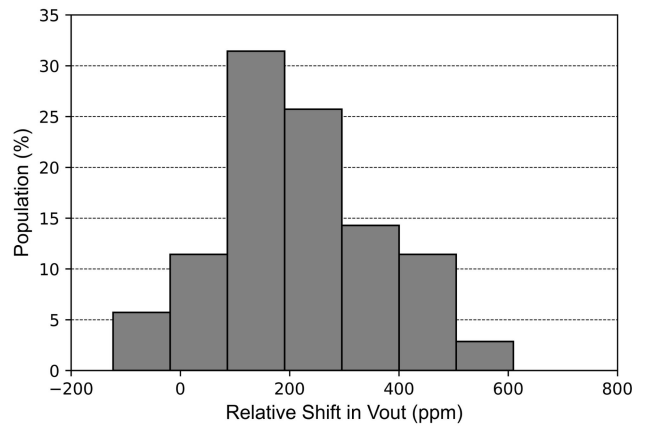

Figure 7.10 Solder Heat Reflow Shift Histogram

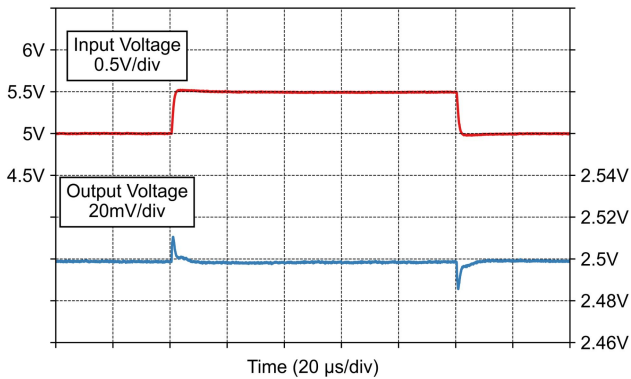

Figure 7.11 Line Transient Response (CL=0)

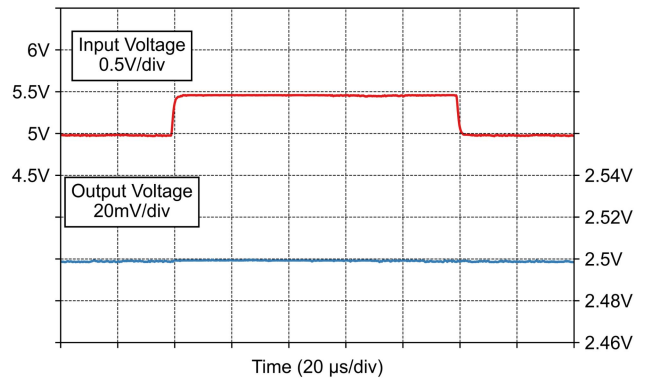

Figure 7.12 Line Transient Response (CL=1uF)



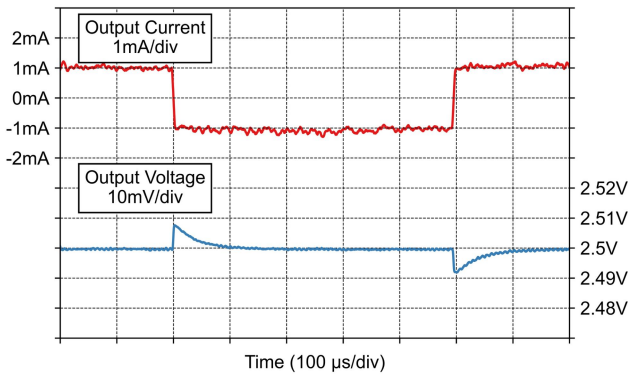

Figure 7.13 Load Transient Response  $\pm 1\text{mA}$  ( $C_L=0$ )

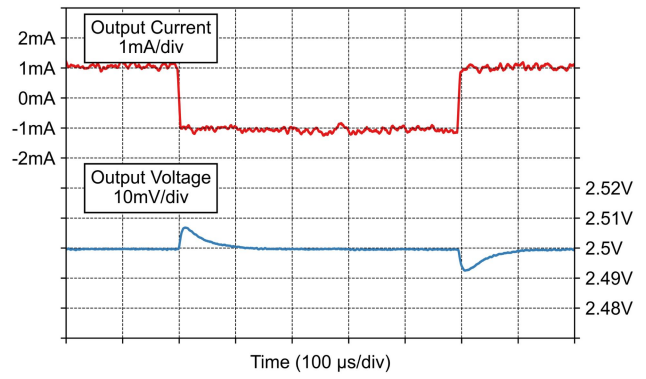

Figure 7.14 Load Transient Response  $\pm 1\text{mA}$  ( $C_L=1\mu\text{F}$ )

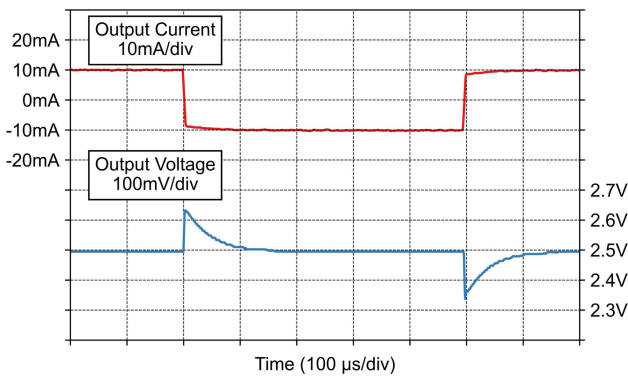

Figure 7.15 Load Transient Response  $\pm 10\text{mA}$  ( $C_L=0$ )

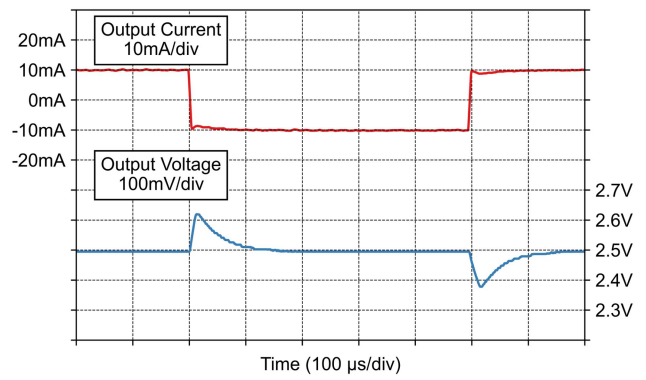

Figure 7.16 Load Transient Response  $\pm 10\text{mA}$  ( $C_L=1\mu\text{F}$ )

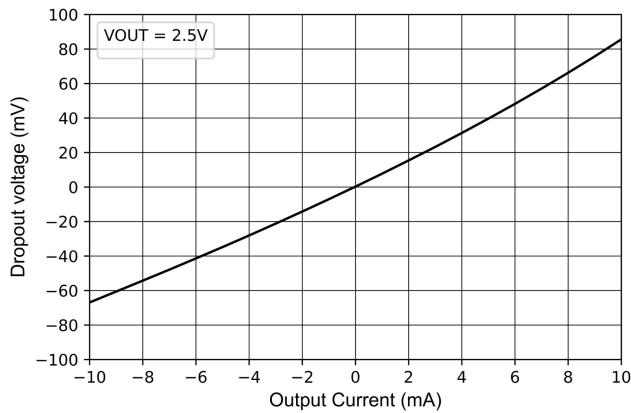

Figure 7.17 Dropout Voltage vs Load Current

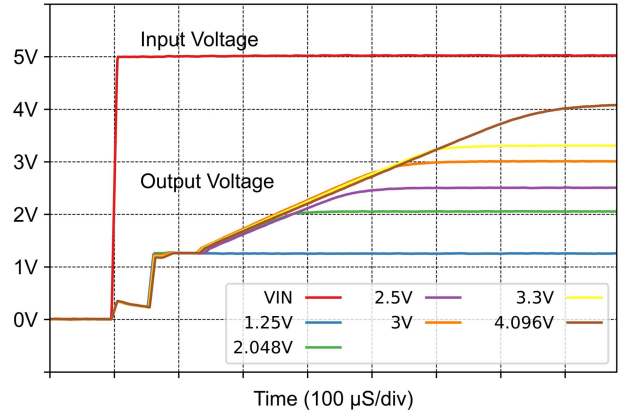

Figure 7.18 Startup Response

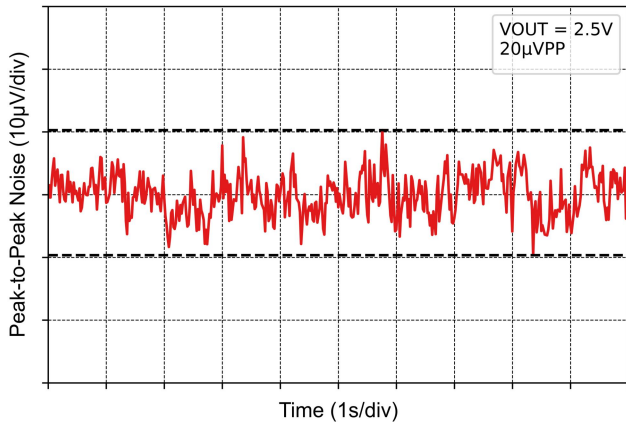

Figure 7.19 0.1Hz to 10Hz Voltage Noise

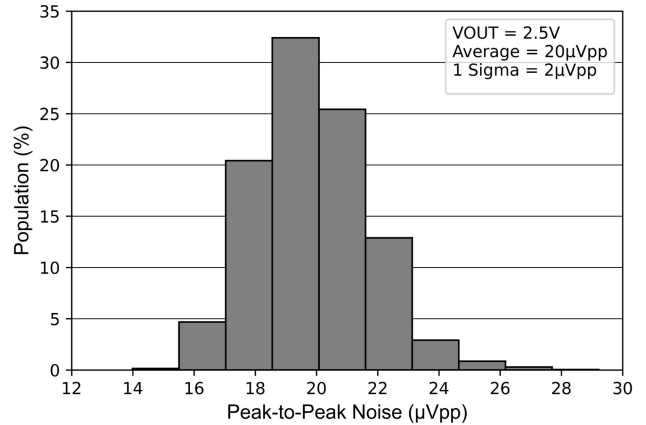

Figure 7.20 0.1Hz to 10Hz Noise Histogram

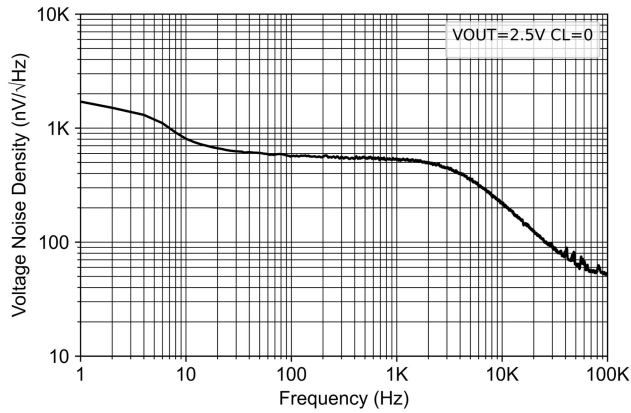

Figure 7.21 Noise Density vs Frequency

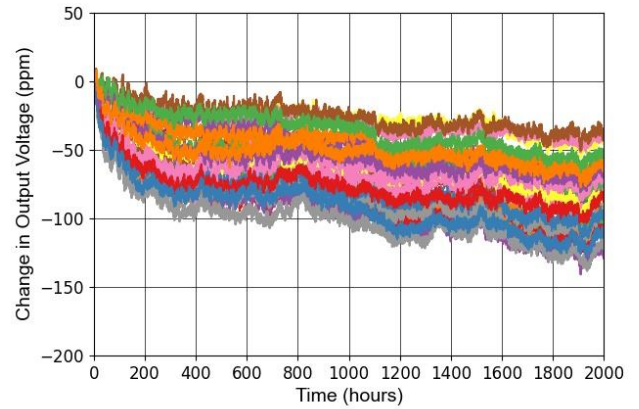

Figure 7.22 Long Term Drift 0 to 2000 hours,  $T_A=35^\circ\text{C}$

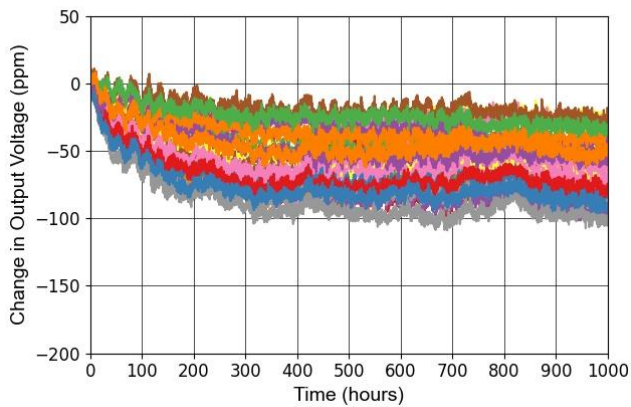

Figure 7.23 Long Term Drift 0 to 1000 hours,  $T_A=35^\circ\text{C}$

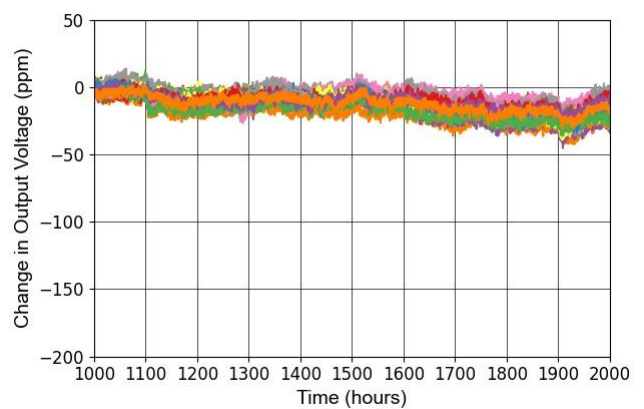

Figure 7.24 Long Term Drift 1000 to 2000 hours,  $T_A=35^\circ\text{C}$

## 8. Application Information

### 8.1. Temperature Coefficient

The temperature coefficient is defined as the change in output voltage over temperature. The temperature coefficient is calculated using the box method in which a box is formed by the minimum and maximum values for the nominal output voltage over the operating temperature range. NSREF30xx series have a low maximum temperature coefficient of 35 ppm/°C from -40°C to +125°C.

$$\text{Temperature Coefficient} = \left( \frac{V_{OUT\_MAX} - V_{OUT\_MIN}}{V_{OUT\_NOMINAL} \times \text{Temperature Range}} \right) \times 10^6$$

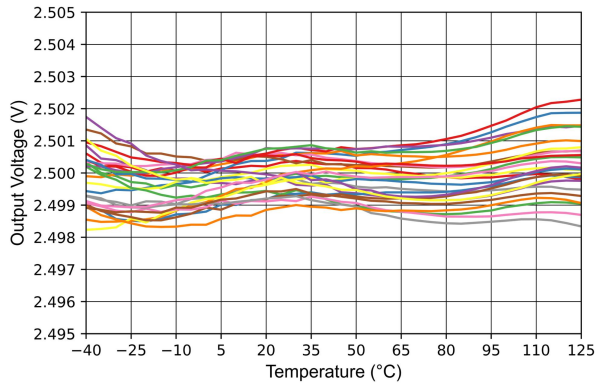

Figure 8.1 Output Voltage vs Temperature

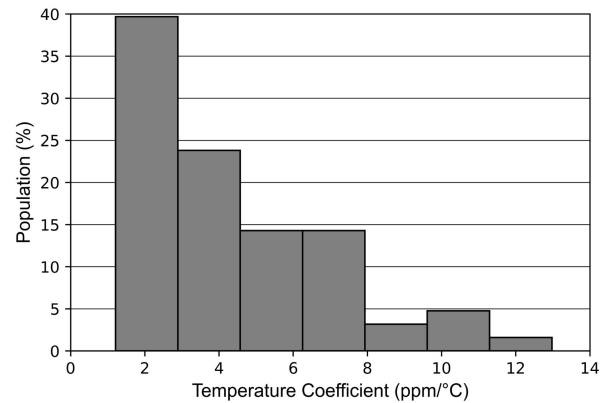

Figure 8.2 Temperature Drift Histogram

The box method specifies limits for the temperature error but does not specify the exact shape and slope of the devices under test. Due to temperature curvature correction to achieve low-temperature drift, the temperature drift is expected to be non-linear. Use for the box method.

### 8.2. Long-Term Stability

The long-term stability value is tested in a setup that reflects standard PCB board manufacturing practices. The boards are made of standard FR4 material and the board does not have special cuts or grooves around the devices to relieve the mechanical stress of the PCB. The devices and boards in this test do not undergo high temperature burn in post-soldering prior to testing. These conditions replicate real-world system performance and common manufacturing techniques. During the long-term stability testing, the devices under test are maintained at  $T_A=35^\circ\text{C}$  in an ultra-stable oil bath, their outputs were scanned regularly and measured with an 8.5 digit DVM.

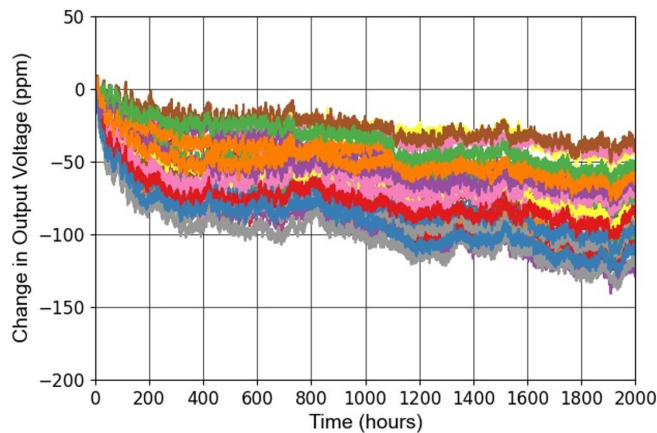

Figure 8.3 Long Term Drift 0 to 2000 hours

Figure 8.3 shows that the typical drift value for the NSREF30xx series is 130 ppm from 0 to 2000 hours. It is important to understand that long-term stability is not ensured by design and that the value is typical. The first 250 hours account most drift, Thus, the early life drift is the dominant contributor, whereas the drift after 250 hours is significantly lower.

### 8.3. Noise Performance

Flicker noise, also known as 1/f noise, is a low-frequency noise that affects the device output voltage which can affect precision measurements in a data acquisition system. This noise increases proportionally with output voltage and operating temperature. NSREF30xx series peak-to-peak flicker noise is measured with a 2-pole high-pass filter at 0.1Hz and 2-pole low-pass filter at 10Hz, and the test time is 10 seconds. Due to the statistical nature of noise, repeating noise measurements will yield larger and smaller peak values in a given measurement interval. By repeating the measurement for 2000 intervals, each 10 seconds long, it is shown that there are time intervals during which the noise is higher than in a typical single interval, as predicted by statistical theory. For the 1000 interval test, a typical unit will exhibit noise that is less than the typical value listed in the Electrical Characteristics table in more than 80% of all units.

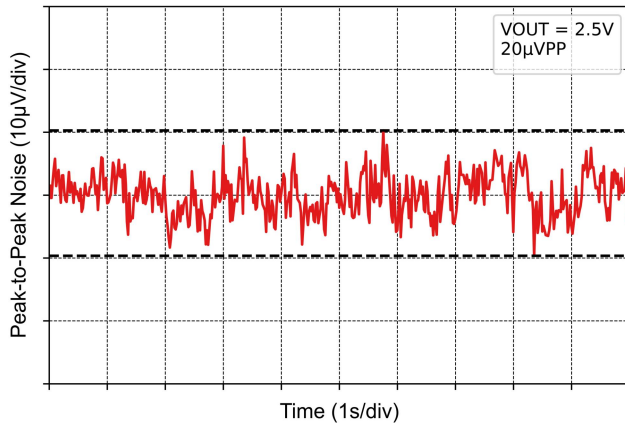

Figure 8.4 0.1Hz to 10Hz Voltage Noise

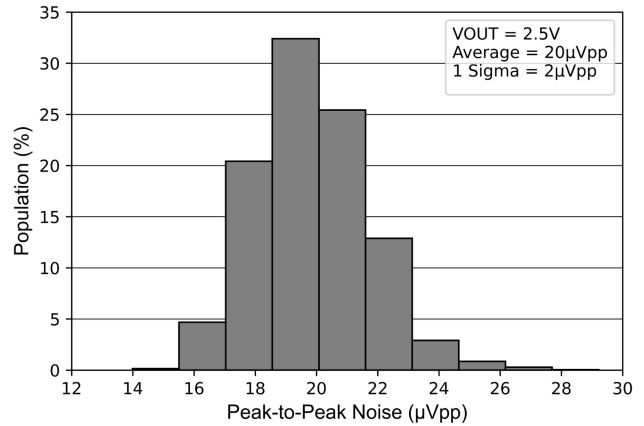

Figure 8.5 0.1Hz to 10Hz Noise Histogram

### 8.4. Typical Voltage Reference Connection

#### 8.4.1. Input Capacitors

The NSREF30xx series require a 1µF or larger input capacitor located close to IN pin to improve transient response in applications where the supply voltage may fluctuate. Connect an additional 0.1µF capacitor in parallel to reduce high frequency supply noise.

#### 8.4.2. Load Capacitors

The NSREF30xx series does not require any output capacitance for frequency stability, an additional 1µF to 10µF electrolytic or ceramic capacitor can be added to improve transient performance in response to sudden changes in load current, however, doing so increases the turn-on time of the device.

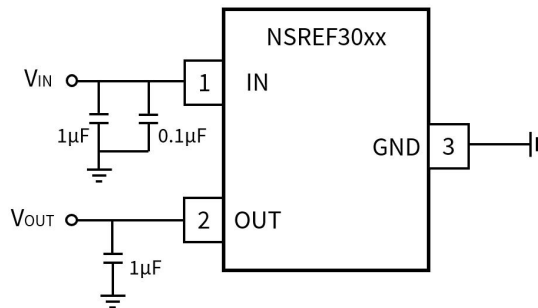

Figure 8.6 The NSREF30xx Typical Application Circuit

### 8.5. Layout Guidelines

- Connect low-ESR, 0.1-µF ceramic bypass capacitors at IN of the NSREF30xx.
- Connect low-ESR, 1-uF to 10-uF capacitor at OUT of the NSREF30xx.
- Decouple other active devices in the system per the device specifications.
- Using a solid ground plane helps distribute heat and reduces electromagnetic interference (EMI) noise pickup.
- Place the external components as close to the device as possible. This configuration prevents parasitic errors from occurring.

### 9. Package Information

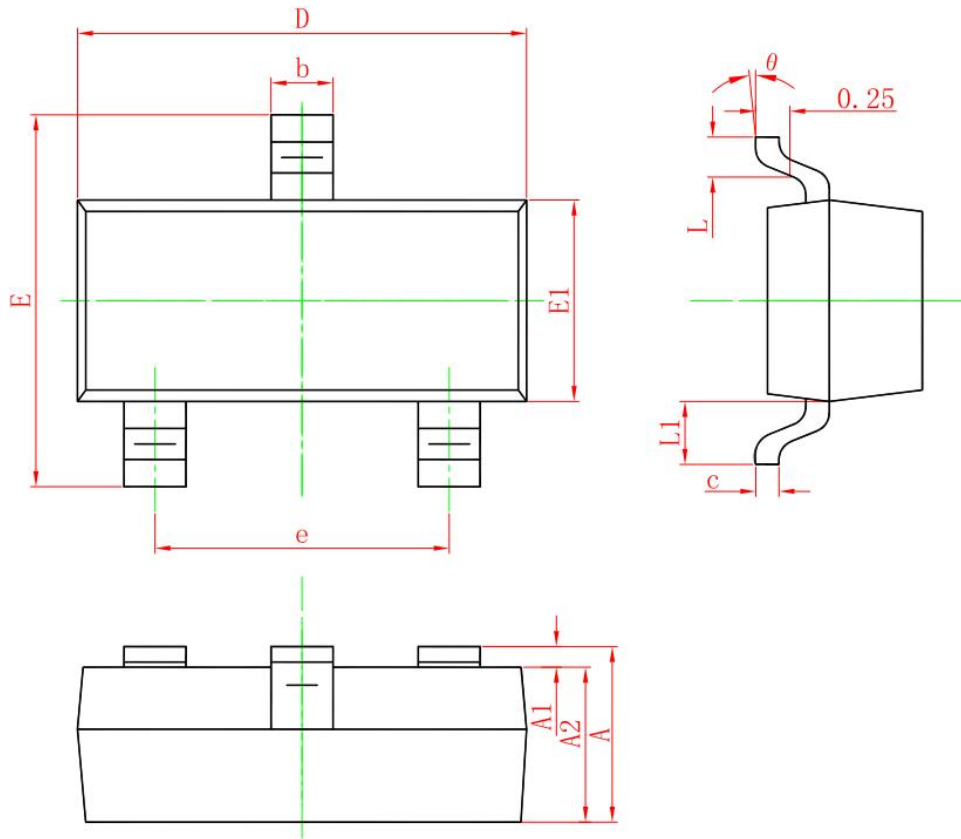

Figure 9.1 SOT23-3L Package Shape and Dimension in millimeters and (inches)

Symbol	Dimensions in Millimeters		Dimensions in Inches	
	Min.	Max.	Min.	Max.
A	1.15Max.		0.045Max.	
A1	0.000	0.100	0.000	0.004
A2	0.900	1.100	0.035	0.043
b	0.300	0.500	0.012	0.020
C	0.132	0.202	0.005	0.008
D	2.800	3.000	0.110	0.118
E	2.250	2.550	0.089	0.100
E1	1.200	1.400	0.047	0.055
e	1.800	2.000	0.071	0.079
L	0.300	0.500	0.012	0.020
L1	0.550 REF.		0.022 REF.	
θ	0°	8°	0°	8°

## 10. Ordering Information

<i>Part Number</i>	<i>MSL</i>	<i>SPQ</i>	<i>Marking</i>	<i>Temperature</i>	<i>Package</i>
NSREF3012-DSTR	1	3000ea/Reel	3012	-40 to 125°C	SOT23-3L
NSREF3020-DSTR	1	3000ea/Reel	3020	-40 to 125°C	SOT23-3L
NSREF3025-DSTR	1	3000ea/Reel	3025	-40 to 125°C	SOT23-3L
NSREF3030-DSTR	1	3000ea/Reel	3030	-40 to 125°C	SOT23-3L
NSREF3033-DSTR	1	3000ea/Reel	3033	-40 to 125°C	SOT23-3L
NSREF3040-DSTR	1	3000ea/Reel	3040	-40 to 125°C	SOT23-3L

NOTE: All packages are RoHS-compliant with peak reflow temperatures of 260 °C according to the JEDEC industry standard classifications and peak solder temperatures.

## 11. Documentation Support

<i>Part Number</i>	<i>Product Folder</i>	<i>Datasheet</i>	<i>Technical Documents</i>
NSREF30xx	<a href="#">Click here</a>	<a href="#">Click here</a>	<a href="#">Click here</a>

### 12. Tape and Reel Information

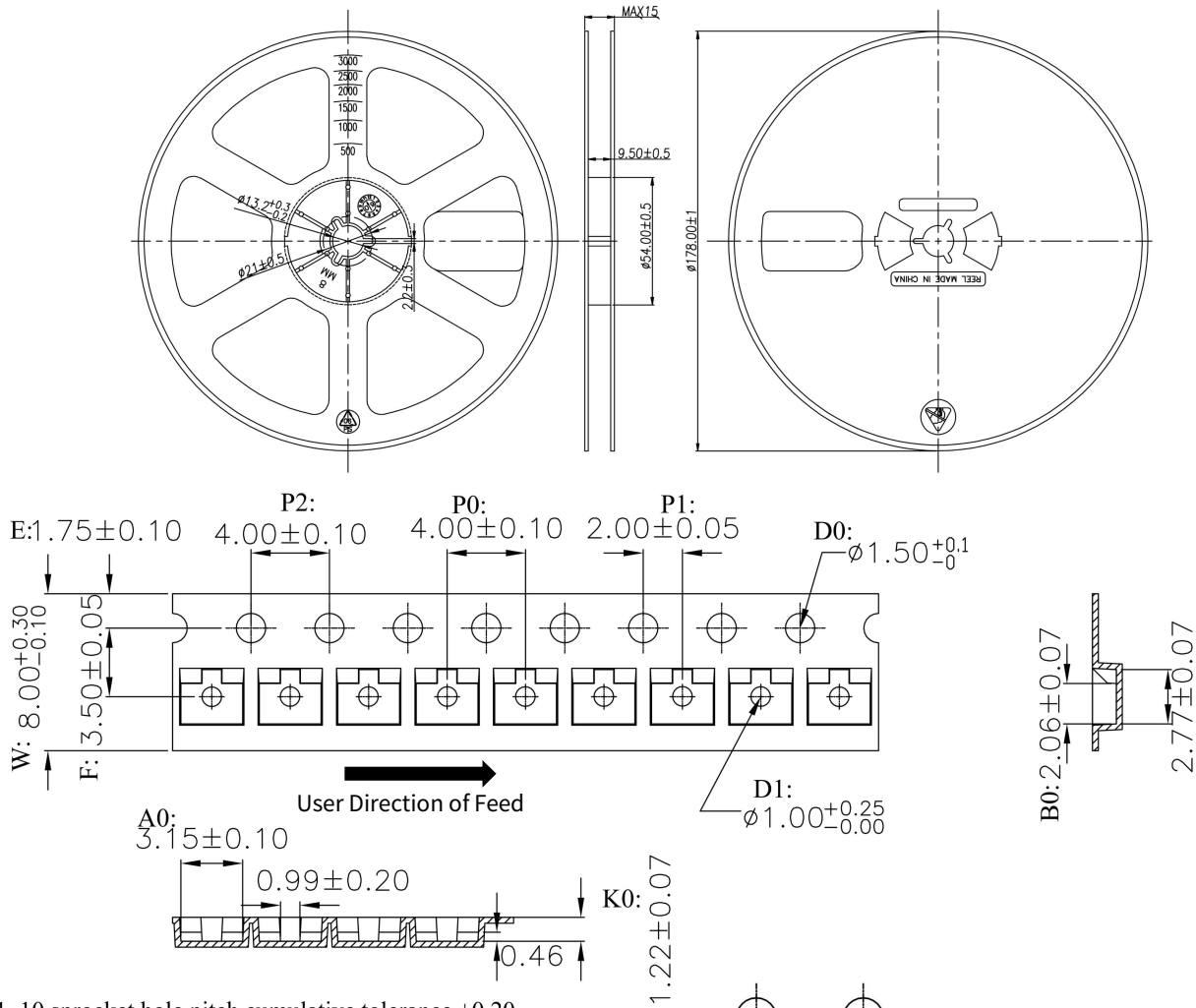

1. 10 sprocket hole pitch cumulative tolerance ±0.20.
2. Carrier camber is within 1 mm in 250 mm.
3. Material : Black Conductive Polystyrene Alloy.
4. All dimensions meet EIA-481 requirements.
5. Thickness : 0.20±0.02mm.
6. Packing length per 19" reel : 1000 Meters.
7. Component load per 13" reel : 10000 pcs.
8. Surface resistivity : 10<sup>5</sup>~10<sup>10</sup>Ω/sq.

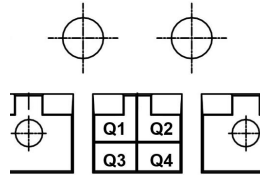

W	8.00+0.3/-0.1
A0	3.15±0.10
B0	2.06±0.07
B1	2.77±0.07
K0	1.22±0.07

Device	Package	D1 (mm)	W1 (mm)	A0 (mm)	D0 (mm)	D2 (mm)	F0 (mm)	K0 (mm)	P0 (mm)	P1 (mm)	P2 (mm)	W (mm)	Pin1 Quadrant
NSREF30xx	SOT23-3L	178	9.5	3.15	1.5	1.0	3.5	1.22	4.0	2.0	4.0	8.0	Q3

### 13. Revision History

Revision	Description	Date
1.0	Initial Version.	2023/10/15



## IMPORTANT NOTICE

The information given in this document (the “Document”) shall in no event be regarded as any warranty or authorization of, express or implied, including but not limited to accuracy, completeness, merchantability, fitness for a particular purpose or infringement of any third party’s intellectual property rights.

Users of this Document shall be solely responsible for the use of NOVOSENSE’s products and applications, and for the safety thereof. Users shall comply with all laws, regulations and requirements related to NOVOSENSE’s products and applications, although information or support related to any application may still be provided by NOVOSENSE.

This Document is provided on an “AS IS” basis, and is intended only for skilled developers designing with NOVOSENSE’ products. NOVOSENSE reserves the rights to make corrections, modifications, enhancements, improvements or other changes to the products and services provided without notice. NOVOSENSE authorizes users to use this Document exclusively for the development of relevant applications or systems designed to integrate NOVOSENSE’s products. No license to any intellectual property rights of NOVOSENSE is granted by implication or otherwise. Using this Document for any other purpose, or any unauthorized reproduction or display of this Document is strictly prohibited. In no event shall NOVOSENSE be liable for any claims, damages, costs, losses or liabilities arising out of or in connection with this Document or the use of this Document.

For further information on applications, products and technologies, please contact NOVOSENSE ([www.novosns.com](http://www.novosns.com)).

**Suzhou NOVOSENSE Microelectronics Co., Ltd**