

Product Overview

The NST1412 is a high accuracy, low cost, local and remote temperature sensor with a system management bus (SMBus). It features an internal temperature sensor and one external temperature sensor interface (the one external remote temperature sensor can be a low-cost NPN or PNP transistor, or a built-in diode for a microprocessor, microcontroller, or field-programmable gate array (FPGA)). The NST1412 supports series resistance cancellation, programmable non-efficiency factor (η -factor), programmable offsets, programmable temperature limits, and programmable digital filters to improve the chip's noise immunity and provide a robust solution for complex thermal environment monitoring applications.

The NST1412 has an operating voltage range of 3V to 3.6V and an operating temperature range of -40°C to 125°C. Both local and remote temperature measurement channel data are represented by an 11-bit digital code with a resolution of 0.125°C. The chip supports both I²C and SMBus communication protocols and can support six fixed slave addresses. Together with ± 1.5 °C measurement accuracy, it provides a low-cost, highly flexible and optimal choice for multi-point temperature measurement in various industrial applications such as communication, computing and instrumentation.

Key Features

- Programmable I²C and SMBus addresses
- Supply voltage range: 3V~3.6V
- Series Resistance Cancellation
- η -Factor and Offset Correction
- Programmable Digital Filter
- Diode Fault Detection
- Local and remote Temperature sensor
- ± 1.5 °C max accuracy (-40 °C < T < 125 °C)

- 0.125 °C resolution
- Programmable temperature limits for ALERT and THERM
- Available in RoHS compliant package: 8-pin MSOP.

Applications

- Notebook Computers
- Desktop Computers
- Industrial
- Embedded applications

Device Information

Part Number	Package	Body Size
NST1412-DMSR	MSOP (8)	4.9mm× 3.0mm

Functional Block Diagrams

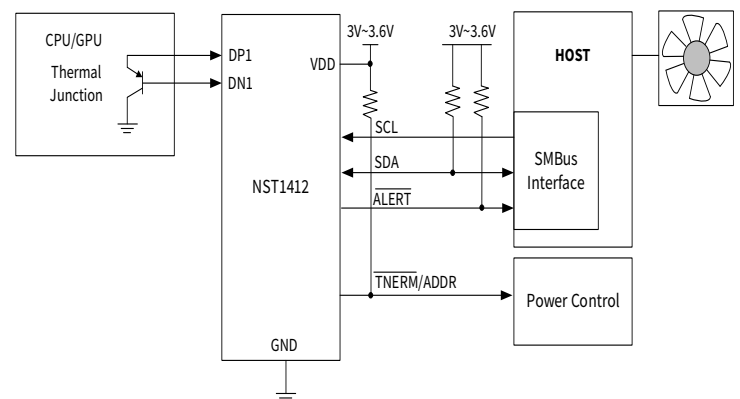

Figure 1. NST1412 Application Diagram

INDEX

1. PIN CONFIGURATION AND FUNCTIONS 4

2. ABSOLUTE MAXIMUM RATINGS 5

3. ELECTRICAL CHARACTERISTICS 6

 3.1. ELECTRICAL CHARACTERISTICS 6

 3.2. I²C TIMING DIAGRAM 7

 3.3. I²C TIMING CHARACTERISTICS 8

4. FUNCTION DESCRIPTION 9

 4.1. FUNCTION DESCRIPTION 9

 4.2. FEATURE DESCRIPTION 9

 4.2.1. DIGITAL TEMPERATURE SENSOR 9

 4.2.2. SERIES RESISTANCE CANCELLATION 10

 4.2.3. DIFFERENTIAL INPUT CAPACITANCE 10

 4.2.4. H-FACTOR CORRECTION 10

 4.2.5. FILTERING 10

 4.2.6. SENSOR FAULT 10

 4.2.7. ALERT AND THERM FUNCTIONS 10

 4.3. DEVICE FUNCTIONAL MODES 11

 4.3.1. SHUTDOWN MODE (SD) 11

 4.3.2. CONTINUOUS MODE 11

 4.4. PROGRAMMING 11

 4.4.1. SERIAL INTERFACE 11

 4.4.2. SERIAL BUS ADDRESS 12

 4.4.3. THERM PIN CONSIDERATIONS 12

 4.4.4. READ AND WRITE OPERATIONS 13

 4.5. TIMEOUT FUNCTION 13

 4.6. HIGH-SPEED MODE 13

 4.7. SMBUS ALERT FUNCTION 13

 4.8. GENERAL-CALL RESET 14

5. REG MAP 15

 5.1. LOCAL AND REMOTE TEMPERATURE REGISTERS 16

 5.2. STATUS REGISTER 16

 5.3. CONFIGURATION REGISTER 16

 5.4. CONVERSION RATE REGISTER 17

 5.5. LIMIT REGISTERS 18

 5.6. SCRATCHPAD REGISTERS 18

 5.7. ONE-SHOT START REGISTER 18

 5.8. CHANNEL MASK REGISTER 19

 5.9. CONSECUTIVE ALERT REGISTER 19

 5.10. THERM HYS REGISTER 20

 5.11. H-FACTOR CORRECTION REGISTER 20

 5.12. FILTER CONTROL REGISTER 21

 5.13. PRODUCT ID REGISTER 21

 5.14. MANUFACTURER ID REGISTER 21

 5.15. REVISION REGISTER 21

6. TYPICAL APPLICATION 22

 6.1. APPLICATION INFORMATION 22

 6.2. TYPICAL APPLICATION 22

7. SUGGESTIONS FOR SELECTION	22
8. PCB LAYOUT	22
9. PACKAGE INFORMATION	23
10. LAND PATTERN	24
11. TAPE AND REEL INFORMATION	25
13. ORDER INFORMATION	27
14. MARKING RULE	27
15. REVISION HISTORY	28

1. Pin Configuration and Functions

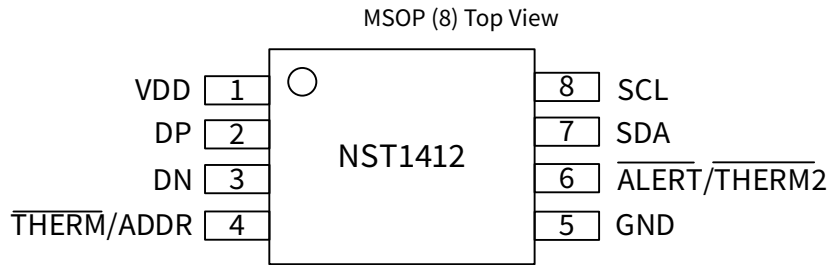

Figure 1.1 NST1412 Package

Table 1.1 NST1412 Pin Configuration and Description

NST1412 PIN NO.	SYMBOL	FUNCTION
1	VDD	Power supply
2	DP	Remote channel positive (anode) connection
3	DN	Remote channel negative (cathode) connection
4	$\overline{\text{THERM}}/\text{ADDR}$	$\overline{\text{THERM}}$ - Critical THERM output signal - requires pull-up resistor, ADDR - Selects SMBus address based on pull-up resistor
5	GND	Ground
6	$\overline{\text{ALERT}}/\overline{\text{THERM2}}$	Active low digital $\overline{\text{ALERT}}/\overline{\text{THERM2}}$ output signal - requires pull-up resistor
7	SDA	SMBus Data input/output - requires pull-up resistor
8	SCL	SMBus Clock input - requires pull-up resistor

2. Absolute Maximum Ratings

Parameters	Symbol	Min	Typ	Max	Unit	Comments
Supply Voltage Pin (VDD)	VDD	-0.3		6	V	
Input voltage	$\overline{\text{THERM}}/\text{ADDR},$ $\overline{\text{ALERT}}/\text{THERM2},$ SDA ,SCL,	-0.3		6	V	
	DP	-0.3		(V+)+0.3	V	
	DN	-0.3		0.3	V	
Input current				10	mA	
Storage temperature	Tstg	-60		150	°C	
Operation temperature	TBoperation	-40		125	°C	
Maximum junction temperature				150	°C	
ESD susceptibility	HBM	±2			KV	
	CDM	±1.25			KV	

3. Electrical Characteristics

3.1. Electrical Characteristics

VDD = 3.0V to 3.6V, TA = -40°C to 125°C, all typical values are at TA = 37°C unless otherwise noted.

Parameters	Symbol	Min	Typ	Max	Unit	Comments
Supply voltage Range	VDD	3	3.3	3.6	V	
Quiescent current	IQ		282	366	uA	Active conversion, local sensor
			416	501	uA	Active conversion, remote sensor
			31		uA	Standby mode (between conversions)
			5		uA	Shutdown mode, serial bus inactive
			11		uA	Shutdown mode, serial bus active, fs = 400 kHz
			39		uA	Shutdown mode, serial bus active, fs = 2.17MHz
			55		uA	Shutdown mode, serial bus active, fs = 3.2MHz
Power-on reset threshold	POR		2		V	Rising edge
Temperature Measurement						
Temperature Range		-40		125	°C	
Temperature Resolution (local and remote)			0.125		°C	
Local temperature sensor accuracy	TA LOCAL	-1	±0.5	1	°C	TA = -10 °C to 105 °C, V = 3.3V
		-1.5	±0.5	1.5	°C	TA = -40 °C to 125 °C, V = 3.3V
Remote temperature sensor accuracy	TA REMOTE	-1	±0.5	1	°C	TA = -10 °C to 105 °C, V = 3.3V
		-1.5	±0.5	1.5	°C	TA = -40 °C to 125 °C, V = 3.3V
Conversion time	TCONV		30		ms	One-shot mode, Conversion Time all Channels
Remote transistor ideality factor	η		1.008			NST1412 optimized ideality factor
Serial Interface						
VIN (1) Logical "1" Input Voltage	VIH	VDD*0.7		VDD+0.3	V	
VIN (0) Logical "0" Input Voltage	VIL	-0.3		VDD*0.3	V	

Hysteresis			200		mV	
SDA output-low sink current		6			mA	
Low-level output voltage	VOL		0.15	0.4	V	$I_O = -6 \text{ mA}$
Serial bus input leakage current		-1		1	μA	$0 \text{ V} \leq V_{IN} \leq 3.6 \text{ V}$
Serial bus input capacitance			3		pF	SCL
			4.6		pF	SDA
Serial bus clock frequency		0.001		3.2	MHz	
Serial bus timeout			25		ms	
Digital DC Characteristics						
IIN (1) Logical "1" Input Current				1	μA	
IIN (0) Logical "0" Input Current				-1	μA	
IOH High Current Level Output Open drain leakage	IOH			1	μA	$V_{OH} = V_{DD}$
Low Level Output Voltage	VOL		0.15	0.4	V	$I_{OL} = 6 \text{ mA}$;
Output-low sink current		6			mA	
Thermal response						
Stirred oil thermal response time to 63% of final value (package only)			0.24		s	MSOP (8)

3.2. I²C Timing Diagram

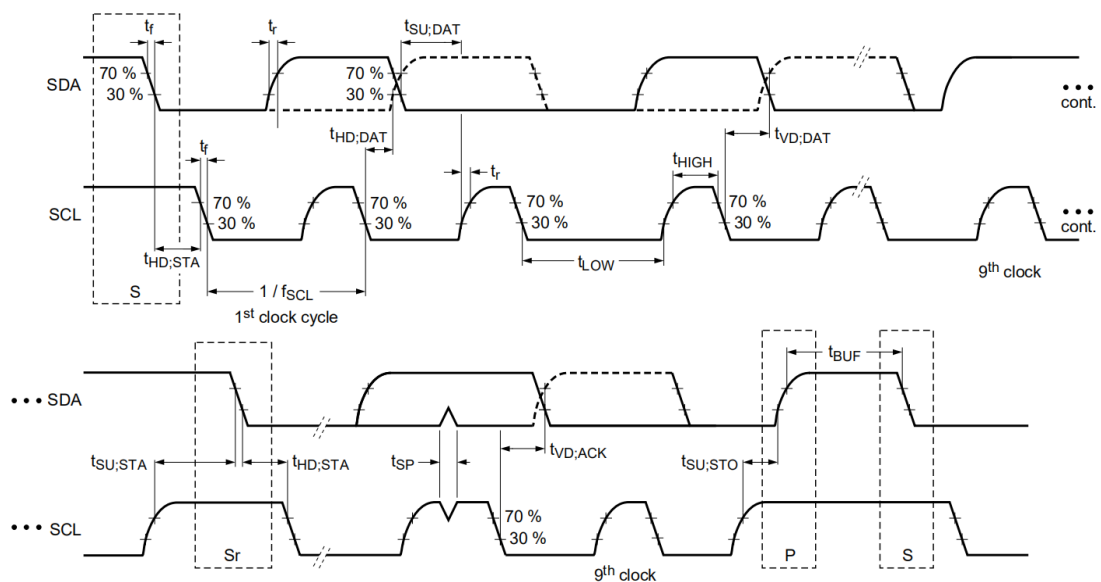

Figure 3.1 I²C Timing Diagram

3.3. I²C Timing Characteristics

Parameters	Symbol	FAST MODE		HIGH-SPEED MODE		Unit	Comments
		Min	Max	Min	Max		
SCL operating frequency	fSCL	0.001	0.4	0.001	3.2	MHz	
Bus-free time between STOP and START conditions	t(BUF)	1300		160		ns	
Hold time after repeated START condition; after this period, the first clock is generated	t(HDSTA)	600		160		ns	
Repeated START condition setup time	t(SUSTA)	600		160		ns	
STOP condition setup time	t(SUSTO)	600		160		ns	
Data hold time	T(HDDAT)	0	900	0	150	ns	
Data setup time	T(SUDAT)	100		40		ns	
SCL clock low period	T(LOW)	1300		320		ns	
SCL clock high period	T(HIGH)	600		60		ns	
Data fall time	tFD		300		130	ns	
Clock rise time	tRC		300		40	ns	
			1000			ns	SCL ≤ 100 kHz
Clock fall time	tFC		300		40	ns	

4. Function Description

4.1. Function Description

The functional block diagram of the NST1412 is shown in Figure 4.1. It supports one local and one remote high-precision temperature sensor, supports six bus addresses, is compatible with SMBUS and I²C interfaces, and the operating temperature range is -40 °C to 125 °C.

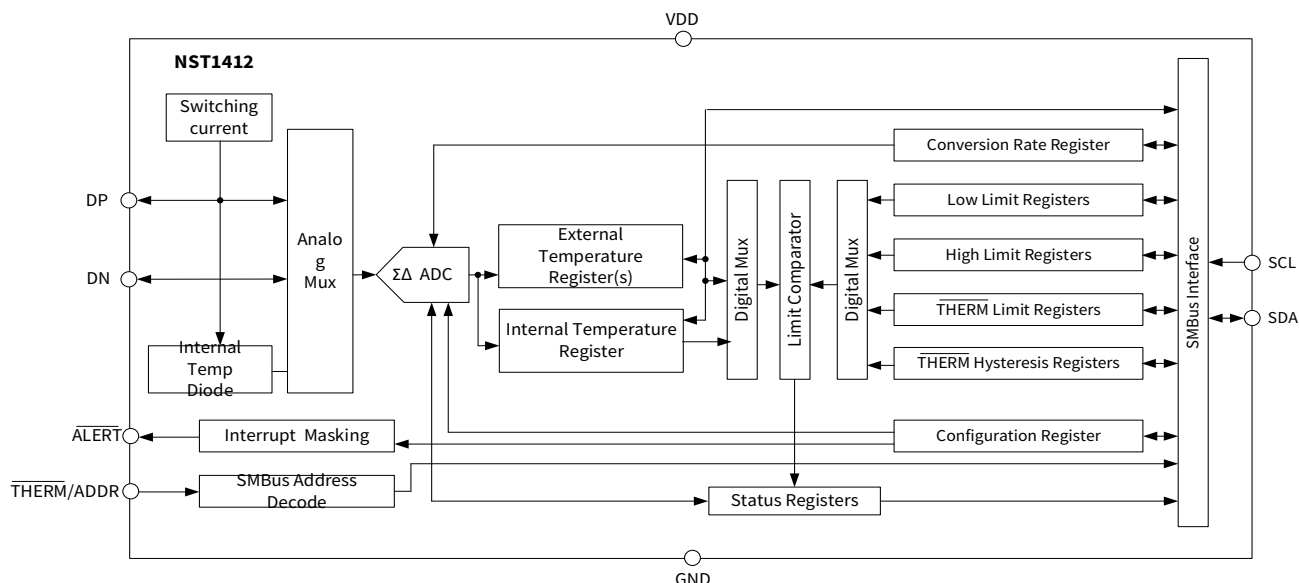

Figure 4.1 NST1412 Functional Block Diagram

4.2. Feature Description

4.2.1. Digital Temperature Sensor

There are two methods of temperature measurement, which are shutdown mode and continuous mode, and the converted data is stored in the corresponding data register. The resolution of all temperature data is 0.125 °C, and the default temperature range is -64 °C to +127.875 °C. You can also configure the register to extend the temperature range to -64 °C to +191 °C. Table 4.1 shows the temperature data format in default and extended mode.

Table 4.1. Temperature Data Format

TEMPERATURE (°C)	DEFAULT RANGE (-64 °C TO 127 °C)	EXTENDED RANGE(-64 °C TO 191 °C)
Diode Fault	110 0000 0000	000 0000 0000
-64	110 0000 0000	000 0000 0000
-1	111 1111 1000	001 1111 1000
0	000 0000 0000	010 0000 0000
0.125	000 0000 0001	010 0000 0001
1	000 0000 1000	010 0000 1000
64	010 0000 0000	100 0000 0000
65	010 0000 1000	100 0000 1000
127	011 1111 1000	101 1111 1000
127.875	011 1111 1111	101 1111 1111
128	011 1111 1111	110 0000 0000
190	011 1111 1111	111 1111 0000
191	011 1111 1111	111 1111 1000
>= 191.875	011 1111 1111	111 1111 1111

Note:

- (1) In the extended range, all temperatures $< -64\text{ }^{\circ}\text{C}$ will be reported as $-64\text{ }^{\circ}\text{C}$.
- (2) For the default range, all temperatures $> +127.875\text{ }^{\circ}\text{C}$ will be reported as $+127.875\text{ }^{\circ}\text{C}$.
- (3) For the extended range, all temperatures $> +191.875\text{ }^{\circ}\text{C}$ will be reported as $+191.875\text{ }^{\circ}\text{C}$.

4.2.2. Series Resistance Cancellation

The series resistance cancellation feature automatically eliminates temperature errors caused by the wiring resistance from the NST1412 to the remote transistor. the NST1412 device can eliminate $1\text{ k}\Omega$ of series resistance, so no additional temperature offset correction is required.

4.2.3. Differential Input Capacitance

The NST1412 device ensures that the temperature error remains small when the differential input capacitance reaches 2000 pF .

4.2.4. η -Factor Correction

The NST1412 allows the remote channel measurements to be converted to temperature values using different η coefficient values. The remote channel uses a continuous current excitation to extract the differential V_{be} voltage measurement and thus determine the temperature of the remote transistor. To provide the user with maximum flexibility, the NST1412 provides a 6-bit register for remote channel that programs the ideality coefficients of the diodes used to eliminate all temperature errors.

4.2.5. Filtering

Remote junction temperature sensors usually work in complex environments. To reduce the impact of noise and temperature spikes on the reported temperature, the NST1412 device has a built-in filter at the remote channel 1 differential input. It is recommended to differentially place a bypass capacitor between 100 pF and 1 nF at the input of the remote temperature sensor to make unnecessary coupling signals more stable. Channel 1 has three levels of filtering, and the specific effect is shown in Figure 4.2 and Figure 4.3.

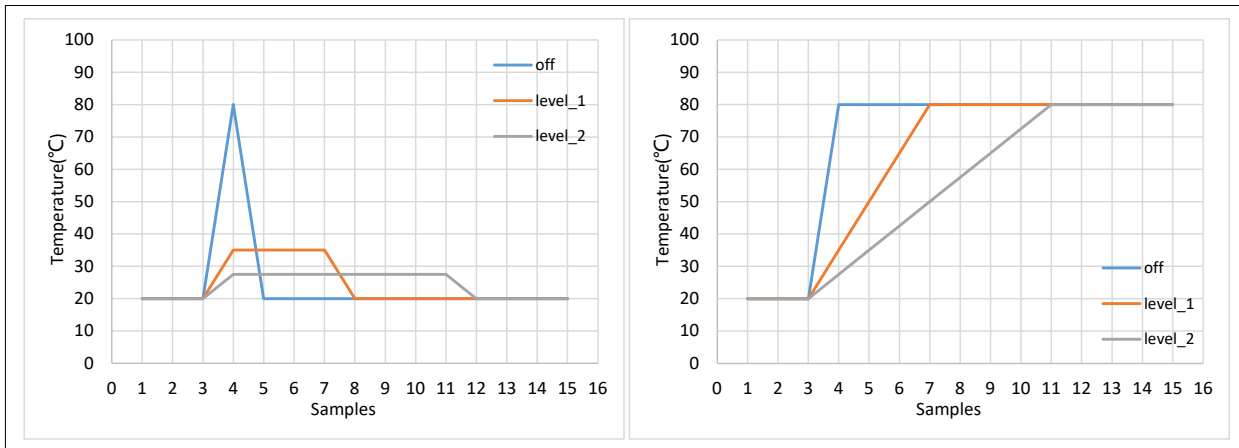

Figure 4.2 Filter Response to Impulse Inputs

Figure 4.3 Filter Response to Step Inputs

4.2.6. Sensor Fault

NST1412 has the ability to detect open and short circuits of DP and DN pins. Each time the temperature is measured, the device will check for diode faults on the remote temperature channel. When a diode fault is detected, the ALERT pin is set to active (unless masked) and returns a temperature measurement of $-64\text{ }^{\circ}\text{C}$ with the corresponding status bit set. A circuit break between DP and DN, a short circuit from VDD to DP, and a short circuit from DP to GND, are all considered diode failures.

4.2.7. Alert and Therm Functions

The NST1412's ALERT and THERM pins respond as shown in Figure 4.4 and Figure 4.5. ALERT and THERM are independent of each other, and THERM cannot be masked. The THERM pin responds when the temperature exceeds the user set number of times the THERM pin is allowed to be triggered until the temperature drops to the user set lower limit of the THERM temperature trigger minus the hysteresis, the response cannot be cleared by reading the status register of the response. the ALERT pin has two modes, interrupt and compare. In interrupt mode, when the temperature value exceeds its maximum limit, the ALERT pin responds and the

corresponding status bit is set up, when the temperature drops to the lower limit of the corresponding temperature value, the response will not be released until the user reads the corresponding status bit and the response is released; in comparison mode, when the temperature exceeds the set maximum limit, ALERT responds and reading the status bit will not release the response status until the temperature drops to the lower limit of the set temperature minus the hysteresis.

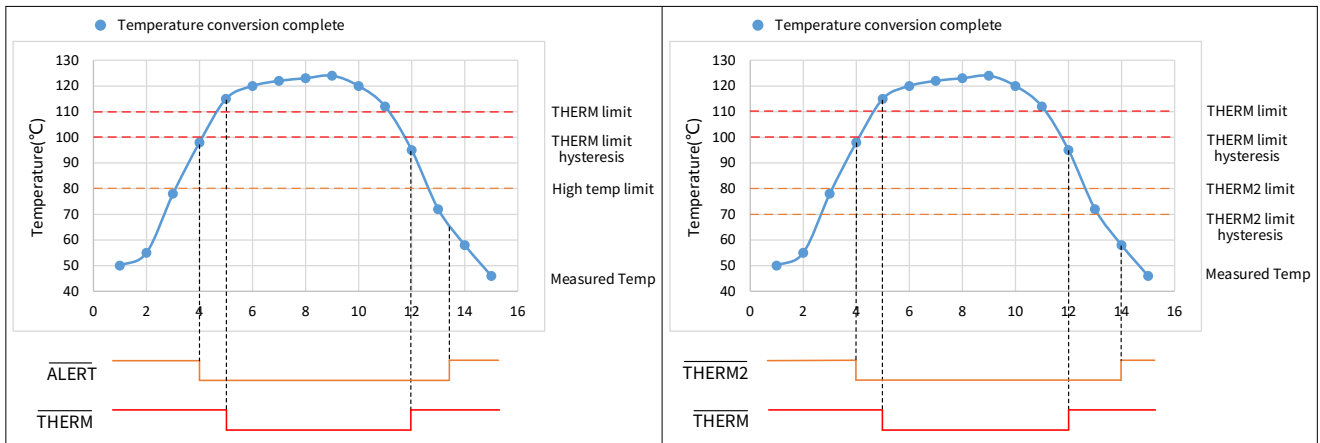

Figure 4.4 $\overline{\text{ALERT}}$ and $\overline{\text{THERM}}$ interrupt operation Figure 4.5 $\overline{\text{THERM}}$ and $\overline{\text{THERM2}}$ interrupt operation

4.3. Device Functional Modes

4.3.1. Shutdown Mode (SD)

The NST1412 shutdown mode is able to ensure the lowest power consumption by turning off all device circuits except the communication interface. When the register (0x0F) is configured, the device will perform a data transition and re-enter the low power mode.

4.3.2. Continuous mode

When the NST1412 is put into continuous operation mode, the device will always perform data conversion to keep the value in the temperature data register up-to-date.

4.4. Programming

4.4.1. Serial Interface

The communication timing diagrams for the write timing and read timing of the NST1412 are shown in Figure 4.6 and Figure 4.7. The NST1412 supports fast (1 kHz ~ 400 kHz) and high-speed (1 kHz ~ 3.2 MHz) transmission protocols and is compatible with up to six devices with different addresses on the bus.

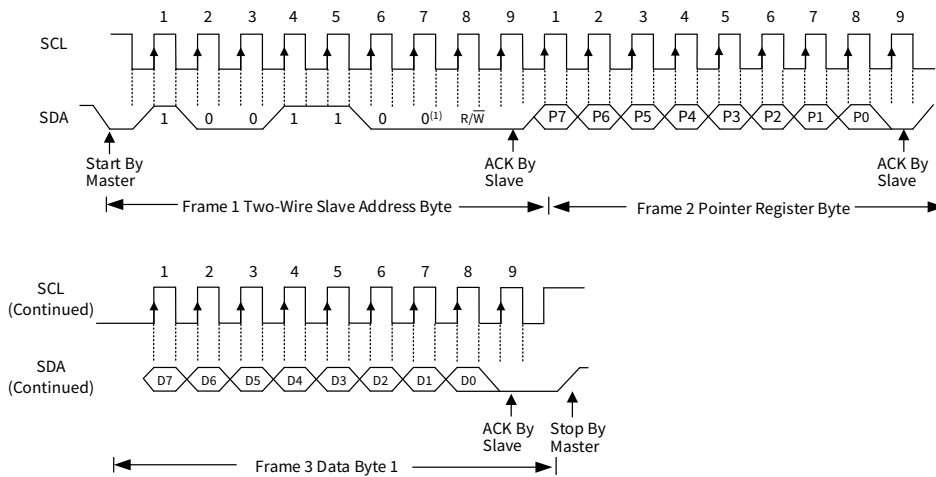

Note:

(1) Slave address 1001100 is shown.

Figure 4.6. Two-Wire Timing Diagram for the NST1412 Write Word Format

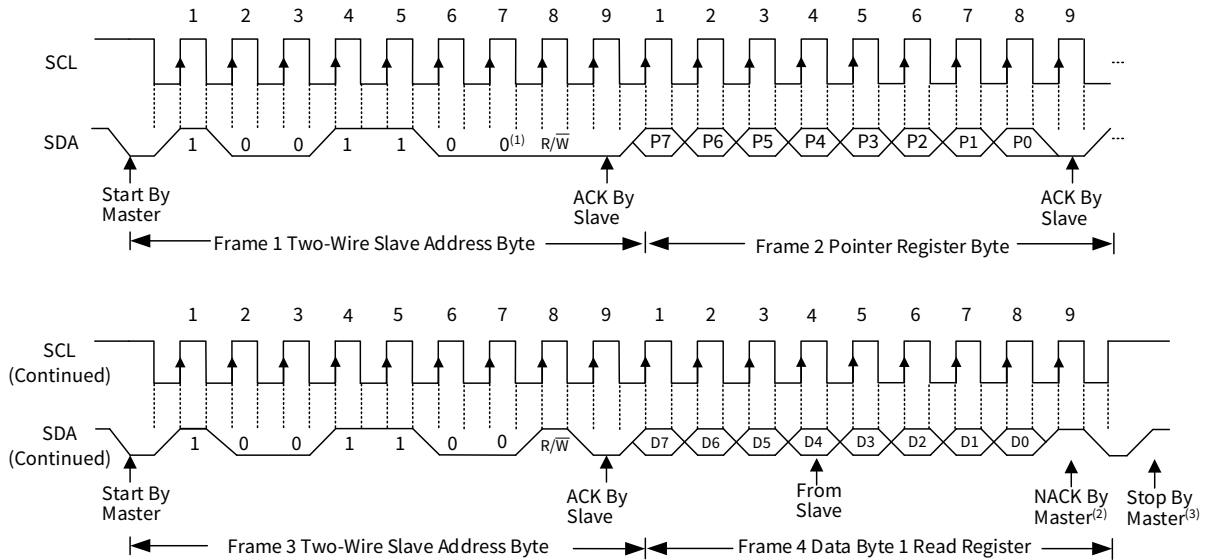

Note:

- (1) Slave address 1001100 is shown.
- (2) The master must leave SDA high to terminate a single-byte read operation.
- (3) Master should leave SDA high to terminate a two-byte read operation.

Figure 4.7. Two-Wire Timing Diagram for Single-Byte Read Format

4.4.2. Serial Bus Address

The slave address can be configured by pulling up resistors of different values on the THERM/ADDR pin to configure the high 7 bits, and the 8th bit is the read/write bit, for a total of six address types.

Table 4.2. SMBus Address Decode

PULL UP RESISTOR ON THERM/ADDR PIN (±5%)	SMBUS ADDRESS	
	BINARY	HEX
4.7k	1111 100	7C
6.8k	1011 100	5C
10k	1001 100	4C
15k	1101 100	6C
22k	0011 100	1C
33k	0111 100	3C

4.4.3. THERM Pin Considerations

If the application requires the therm pin level to be low during power-on, isolation is needed to ensure that the device is functioning properly. At this point, R1 can only use 22K, R2 can only use 4.7K or 33K, please follow the recommended application circuit specifications.

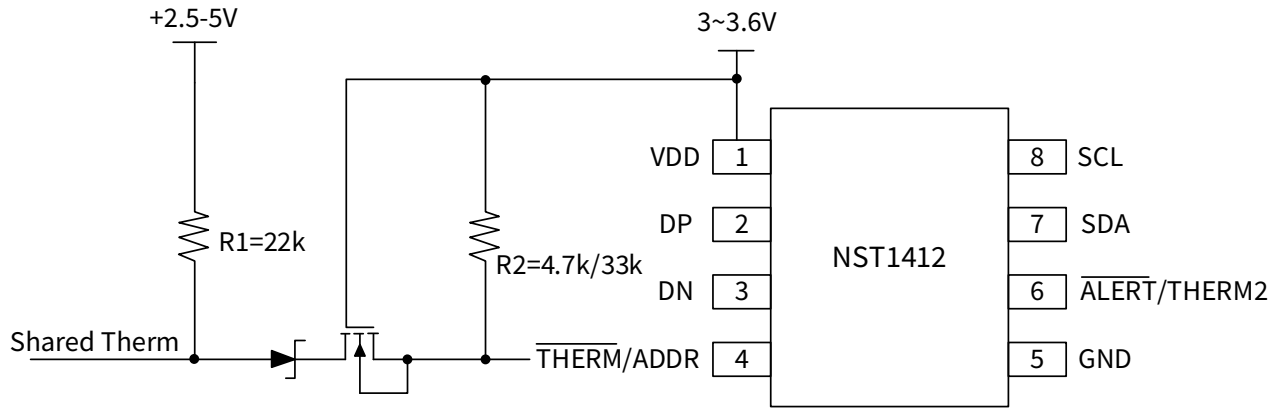

Figure 4.8. Isolating THERMPin

Table 4.3. SMBus Address Decode(Isolating therm pin)

PULL UP RESISTOR ON THERM/ADDR PIN (±5%)	SMBUS ADDRESS	
	BINARY	HEX
4.7k	1111 100	7C
33k	0111 100	3C

4.4.4. Read and Write Operations

When reading temperature data register data, the NST1412 supports continuous read data mode, where 2 bytes are read repeatedly in the same data register to read out the complete data high byte and low byte without continuously sending pointer register bytes.

4.5. Timeout Function

If SCL is pulled low for more than 25ms, the bus timeout function will be triggered, at which time the device will release the bus and wait for the start condition. This function can prevent bus communication abnormalities due to NST1412.

4.6. High-Speed Mode

The NST1412 supports high-speed mode. The master device switches the bus to high-speed operation by sending the high-speed mode command code (0000 1xxx) after the bus start condition, when the fastest signal transmission speed of 3.2MHz will be supported. Until the bus receives a stop signal, the device switches to fast mode.

4.7. SMBus Alert Function

Figure 4.9 shows that when multiple products are mounted on the bus, if the device alert responds, it can broadcast 0001_100X on the bus, at which time the alert responding devices will return the slave address of the responding device in turn.

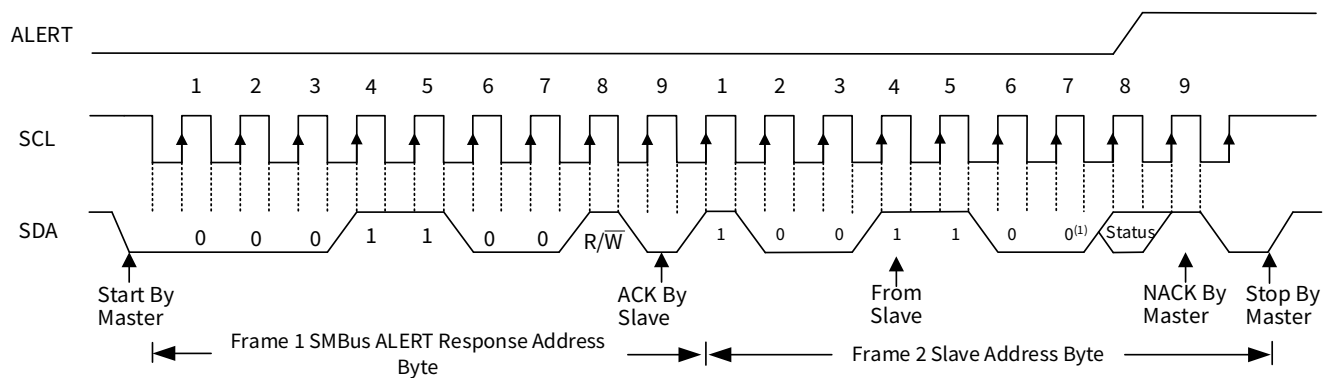

Note:

(1) Slave address 1001100 is shown.

Figure 4.9. SMBus Alert Function

The NST1412 will respond to the ARA in the following way:

Send Slave Address and verify that full slave address was sent (i.e. the SMBus communication from the device was not prematurely stopped due to a bus contention event).

Set the MASK bit to clear the $\overline{\text{ALERT}}$ pin.

Application Note: The ARA does not clear the Status Register and if the MASK bit is cleared prior to the Status Register being cleared, the $\overline{\text{ALERT}}$ pin will be reasserted.

4.8. General-Call Reset

The NST1412 device supports reset using the two-wire general-call address 00h (0000 0000b). The NST1412 device acknowledges the general-call address and responds to the second byte. If the second byte is 06h (0000 0110b), the NST1412 device executes a software reset. This software reset restores the power-on reset state to all NST1412 registers and aborts any conversion in progress. The NST1412 device takes no action in response to other values in the second byte.

5. Reg Map

The NST1412 device contains several registers to hold configuration information, temperature measurements, and status information. These registers are described in Table 5.1.

Table 5.1. Register Map

REGISTER ADDRESS (HEX)	SHARED ADDRESS (HEX)	R/W	Default	Register Description
0	N/A	R	0	Local Temperature Register (high byte)
1	N/A	R	0	Remote Temperature Register (high byte)
2	N/A	R-C	0	Status Register
3	9	R/W	0	Configuration Register
4	0A	R/W	6	Conversion Rate Register (4/sec)
5	0B	R/W	55	Local Temperature High Limit Register (85°C)
6	0C	R/W	0	Local Temperature Low Limit Register (0°C)
7	0D	R/W	55	Remote Temperature High Limit Register (high byte, 85°C)
8	0E	R/W	0	Remote Temperature Low Limit Register (high byte, 0°C)
0F	N/A	W	0	One-Shot Start Register
10	N/A	R	0	Remote Temperature1 Register (low byte)
11	N/A	R/W	0	Scratchpad register
12	N/A	R/W	0	Scratchpad register
13	N/A	R/W	0	Remote Temperature High Limit Register (low byte)
14	N/A	R/W	0	Remote Temperature Low Limit Register (low byte)
19	N/A	R/W	55	Remote Temperature1 THERM Limit Register (85°C)
1F	N/A	R/W	0	Controls the masking of individual channels
20	N/A	R/W	55	Local Temperature THERM Limit Register (85°C)
21	N/A	R/W	0A	THERM Hysteresis Register (10°C)
22	N/A	R/W	70	Consecutive ALERT Register
27	N/A	R/W	12	η -Factor for Remote Temperature 1(1.008)
29	N/A	R	0	Local Temperature Register (low byte)
40	N/A	R/W	0	Filter Control
FD	N/A	R	20	Product ID
FE	N/A	R	5D	Manufacturer ID
FF	N/A	R	4	Revision

5.1. Local and Remote Temperature Registers

Table 5.2. Temperature Data Registers

Write Addr	Read Addr	R/W	Bit7	Bit6	Bit5	Bit4	Bit3	Bit2	Bit1	Bit0	Default	Description
00	00	R	128	64	32	16	8	4	2	1	00	Local Temperature Register (high byte)
01	01	R	128	64	32	16	8	4	2	1	00	Remote 1 Temperature Register (high byte)
10	10	R	0.5	0.25	0.125	0	0	0	0	0	00	Remote 1 Temperature Register (low byte)
29	29	R	0.5	0.25	0.125	0	0	0	0	0	00	Local Temperature Register (low byte)

As shown in the above table, both local and remote temperature data are composed of 11 bits of valid data, and the minimum separation rate is 0.125°C

5.2. Status Register

Table 5.3. Status Register Format

Write Addr	Read Addr	R/W	Bit7	Bit6	Bit5	Bit4	Bit3	Bit2	Bit1	Bit0	Default	Description
02	02	R	BUSY	LHIGH	LLOW	RHIGH	RLOW	OPEN	RTHRM	LTHRM	00	Status Registers

This register mainly contains the ADC status register and the sensor alarm status of each channel.

- Bit 7 - BUSY - This bit indicates that the ADC is currently converting. This bit does not cause either the $\overline{\text{ALERT}}$ or $\overline{\text{THERM}}$ pins to be asserted.
- Bit 6 - LHIGH - This bit is set when the Local channel exceeds its programmed high limit. When set, this bit will assert the ALERT pin.
- Bit 5 - LLOW - This bit is set when the Local channel drops below its programmed low limit. When set, this bit will assert the ALERT pin.
- Bit 4 - RHIGH - This bit is set when the remote channel exceeds its programmed high limit. When set, this bit will assert the ALERT pin.
- Bit 3 - RLOW - This bit is set when the remote channel drops below its programmed low limit. When set, this bit will assert the ALERT pin.
- Bit 2 - OPEN - This bit is asserted when a diode fault is detected on any of the channels. When set, this bit will assert the $\overline{\text{ALERT}}$ pin.
- Bit 1 - RTHRM - This bit is set when the remote channel exceeds the programmed Therm Limit. When set, this bit will assert the THERM pin. This bit will remain set until the THERM pin is released at which point it will be automatically cleared.
- Bit 0 - LTHRM - This bit is set when the local channel exceeds the programmed Therm Limit. When set, this bit will assert the THERM pin. This bit will remain set until the THERM pin is released at which point it will be automatically cleared.

5.3. Configuration Register

Table 5.4. Configuration Register Bit Descriptions

Write Addr	Read Addr	R/W	Bit7	Bit6	Bit5	Bit4	Bit3	Bit2	Bit1	Bit0	Default	Description
09	03	W/R	MASK_ALL	RUN/SD	ALERT/THERM2	0	0	RANGE	0	0	00	Configuration Register

This register mainly contains the configuration that controls the alarm switch of the sensor, the operating mode, the alarm pin expansion, and the measurable temperature range

- Bit 7 - MASK_ALL - Masks the $\overline{\text{ALERT}}$ pin from asserting.
 - '0' (default) - The $\overline{\text{ALERT}}$ pin is not masked. If any of the appropriate status bits are set the $\overline{\text{ALERT}}$ pin will be asserted.
 - '1' - The $\overline{\text{ALERT}}$ pin is masked. It will not be asserted for any interrupt condition unless it is configured in comparator mode. The Status Registers will be updated normally.
- Bit 6 - RUN/SD - enables or disables the temperature-measurement circuitry.
 - '0' (default) - The device is in Active mode and converting on all channels.
 - '1' - The device is in shutdown mode and a single conversion can be started by writing to the one-shot start register; see the One-Shot Start Register section for more information.
- Bit 5 - $\overline{\text{ALERT}}/\overline{\text{THERM2}}$ - Controls the operation of the $\overline{\text{ALERT}}$ pin.
 - '0' (default) - The $\overline{\text{ALERT}}$ pin acts as described in Section 4.2.7.
 - '1' - The $\overline{\text{ALERT}}$ pin acts in $\overline{\text{THERM2}}$ mode as described in Section 4.2.7. In this mode the MASK_ALL bit is ignored.
- Bit 2 - RANGE - Configures the measurement range and data format of the temperature channels.
 - '0' (default) - The temperature measurement range is -64 °C to +127.875 °C and the data format is binary.
 - '1' -The temperature measurement range is -64 °C to +191.875 °C and the data format is offset binary.

5.4. Conversion Rate Register

Table 5.5. Conversion Rate Register

Write Addr	Read Addr	R/W	Bit7	Bit6	Bit5	Bit4	Bit3	Bit2	Bit1	Bit0	Default	Description
0A	04	WR	0	0	0	0	CR3	CR2	CR1	CR0	06	Conversion Rate Register

Table 5.6. Conversion Rate

VALUE	CONVERSIONS PER SECOND	TIME (Seconds)
00h	0.0625	16
01h	0.125	8
02h	0.25	4
03h	0.5	2
04h	1	1
05h	2	0.5
06h	4(default)	0.25(default)
07h	8	0.125
08h	16	0.0625
0B-0Fh	1	1

Tables 5.5 and 5.6 show the data conversion rates represented by the different codes configured.

5.5. Limit Registers

Table 5.7. Temperature Limit Registers

Write Addr	Read Addr	R/W	Bit7	Bit6	Bit5	Bit4	Bit3	Bit2	Bit1	Bit0	Default	Description
0B	05	WR	128	64	32	16	8	4	2	1	55	Local Temperature High Limit Register
0C	06	WR	128	64	32	16	8	4	2	1	00	Local Temperature Low Limit Register
0D	07	WR	128	64	32	16	8	4	2	1	55	Remote Temperature High Limit Register (high byte)
0E	08	WR	128	64	32	16	8	4	2	1	00	Remote Temperature Low Limit Register (high byte)
13	13	WR	0.5	0.25	0.125	0	0	0	0	0	00	Remote Temperature High Limit Register (low byte)
14	14	WR	0.5	0.25	0.125	0	0	0	0	0	00	Remote Temperature low Limit Register (low byte)
19	19	WR	128	64	32	16	8	4	2	1	55	Remote Temperature THERM Limit Register
20	20	WR	128	64	32	16	8	4	2	1	55	Local Temperature THERM Limit Register

Table 5.7 contains the threshold setting registers of all states. When the temperature reaches the threshold condition set by the corresponding register, alarms (including Alert and THERM) in the corresponding mode will be triggered. In addition, if the device works in the low-power mode, a data conversion (Start one shot) is required to refresh the alarm state. According to the latest conversion data to determine whether to trigger or close the alarm state, if the alert is masked, the normal alarm can not be carried out, THERM in any working state can not be masked.

5.6. Scratchpad Registers

Table 5.8. Scratchpad Registers

Write Addr	Read Addr	R/W	Bit7	Bit6	Bit5	Bit4	Bit3	Bit2	Bit1	Bit0	Default	Description
11	R/W	0	0	0	0	0	0	0	0	0	00	Scratchpad
12	R/W	0	0	0	0	0	0	0	0	0	00	Scratchpad

These two registers are editable and readable registers configured by the client software to help the client store some important data.

5.7. One-Shot Start Register

Table 5.9. One-Shot Start Register

Write Addr	Read Addr	R/W	Bit7	Bit6	Bit5	Bit4	Bit3	Bit2	Bit1	Bit0	Default	Description
0F	0F	W	NA	NA	NA	NA	NA	NA	NA	NA	NA	start one shot

When the device is in low power state, a data conversion can be performed immediately after any value is written to the register. When the device is in continuous working mode, the register writing operation will not take effect.

5.8. Channel Mask Register

Table 5.10. Channel Mask Register

Write Addr	Read Addr	R/W	Bit7	Bit6	Bit5	Bit4	Bit3	Bit2	Bit1	Bit0	Default	Description
1F	1F	WR	-	-	-	-	-	-	RT_MASK	LT_MASK	00	Channel Mask

This register is used to mask the trigger of the alert pin of a single channel. When the corresponding channel masking function is enabled, the alert pin will not make any alarm, and this register is invalid for the THERM pin.

- Bit 1 - RT1_MASK- Masks the $\overline{\text{ALERT}}$ pin from asserting when the Remote Temperature channel is out of limit or reports a diode fault.
 - '0' (default) - The Remote Temperature will cause the $\overline{\text{ALERT}}$ pin to be asserted if it is out of limit or reports a diode fault.
 - '1' - The Remote Temperature will not cause the $\overline{\text{ALERT}}$ pin to be asserted if it is out of limit or reports a diode fault.
- Bit 0 - LT_MASK- Masks the $\overline{\text{ALERT}}$ pin from asserting when the Local temperature is out of limit.
 - '0' (default) - The Local temperature will cause the $\overline{\text{ALERT}}$ pin to be asserted if it is out of limit.
 - '1' - The Local temperature will not cause the $\overline{\text{ALERT}}$ pin to be asserted if it is out of limit.

5.9. Consecutive ALERT Register

Table 5.11. Consecutive ALERT Register

Write Addr	Read Addr	R/W	Bit7	Bit6	Bit5	Bit4	Bit3	Bit2	Bit1	Bit0	Default	Description
22	22	WR	TIME OUT	CTHRM 2	CTHRM 1	CTHRM 0	CALRT2	CALRT1	CALRT0	-	70	Consecutive ALERT Register

Consecutive Alert Register mainly includes the timeout function control switch, THERM or Alert pin trigger number configuration register. When the alarm trigger times reach the preset value, the corresponding pin will respond, the corresponding status register and the status register of the corresponding channel will be set to 1, and the alarm trigger count will be cleared to zero for the next measurement.

- Bit 7 - TIMEOUT - Determines whether the SMBus Timeout function is enabled.
 - '0' (default) - The SMBus Timeout feature is disabled. The SCL line can be held low indefinitely without the device resetting its SMBus protocol.
 - '1' - The SMBus Timeout feature is enabled. If the SCL line is held low for more than 30ms, the device will reset the SMBus protocol.
- Bits 6-4 - CTHRM [2:0] - Determines the number of consecutive measurements that must exceed the corresponding Therm Limit before the $\overline{\text{THERM}}$ pin is asserted. All temperature channels use this value to set the respective counters. The consecutive Therm counter is incremented whenever any measurement exceeds the corresponding Therm Limit.
- Bits 3-1 - CALRT [2:0] - Determine the number of consecutive measurements that must have an out of limit condition or diode fault before the $\overline{\text{ALERT}}$ pin is asserted. All temperature channels use this value to set the respective counters. The bits are decoded as shown in Table 5.12. The default setting is 1 consecutive out of limit conversion.

Table 5.12. Consecutive Alert / Therm Settings

<i>bit2</i>	<i>bit1</i>	<i>bit0</i>	NUMBER OF CONSECUTIVE OUT OF LIMIT MEASUREMENTS
0	0	0	1 (default for CALRT [2:0])
0	0	1	2
0	1	1	3
1	1	1	4 (default for CTHRM [2:0])

5.10. THERM Hys Register

Table 5.13. THERM Hys Register

Write Addr	Read Addr	R/W	Bit7	Bit6	Bit5	Bit4	Bit3	Bit2	Bit1	Bit0	Default	Description
21	21	WR	128	64	32	16	8	4	2	1	0A	THERM Hys Register

When the temperature is higher than the threshold set by THERM minus hysteresis value, THERM pin alarm will be triggered, when the temperature is lower than the threshold set by THERM minus hysteresis value, THERM pin state will not immediately remove the alarm, need to manually refresh the status register can refresh the alarm state.

5.11. η-Factor Correction Register

Table 5.14. η-Factor Registers

Write Addr	Read Addr	R/W	Bit7	Bit6	Bit5	Bit4	Bit3	Bit2	Bit1	Bit0	Default	Description
27	27	WR	RT1 n Factor[7:0]								12	RT1 n Factor

This register is used to adjust the different ideal factors used by the application for different sensors. Table 5.15 shows the actual ideal factors for different codes.

Table 5.15. η-Factor Look-Up Table

SETTING	FACTOR	SETTING	FACTOR	SETTING	FACTOR
8	0.9949	18	1.0159	28	1.0371
9	0.9962	19	1.0172	29	1.0384
A	0.9975	1A	1.0185	2A	1.0397
B	0.9988	1B	1.02	2B	1.041
C	1.0001	1C	1.0212	2C	1.0423
D	1.0014	1D	1.0226	2D	1.0436
E	1.0027	1E	1.0239	2E	1.0449
F	1.004	1F	1.0253	2F	1.0462
10	1.0053	20	1.0267	30	1.0475
11	1.0066	21	1.028	31	1.0488
12	1.008	22	1.0293	32	1.0501
13	1.0093	23	1.0306	33	1.0514
14	1.0106	24	1.0319	34	1.0527
15	1.0119	25	1.0332	35	1.054
16	1.0133	26	1.0345	36	1.0553
17	1.0146	27	1.0358	37	1.0566

5.12. Filter Control Register

Table 5.16. Filter Configuration Register

Write Addr	Read Addr	R/W	Bit7	Bit6	Bit5	Bit4	Bit3	Bit2	Bit1	Bit0	Default	Description
40	40	WR	0	0	0	0	0	0	DF1	DF0	00	Digital Filter Control Register

Only remote channel of the device has filter function, with two different levels, the specific configuration code is shown in the following table.

- Bits 1-0 – FILTER [1:0] - Control the level of digital filtering that is applied to the Remote Temperature .

Table 5.17. FILTER Decode

FILTER [1:0]		DESCRIPTION
1	0	
0	0	Disabled (default)
0	1	Level 1
1	0	Level 1
1	1	Level 2

5.13. Product ID Register

Table 5.18. Product ID Register

Write Addr	Read Addr	R/W	Bit7	Bit6	Bit5	Bit4	Bit3	Bit2	Bit1	Bit0	Default	Description
FD	FD	R	0	0	1	0	0	0	0	0	20	Product ID

The Product ID Register holds a unique value that identifies the device.

5.14. Manufacturer ID Register

Table 5.19. Manufacturer ID Register

Write Addr	Read Addr	R/W	Bit7	Bit6	Bit5	Bit4	Bit3	Bit2	Bit1	Bit0	Default	Description
FE	FE	R	0	1	0	1	1	1	0	1	5D	Manufacturer ID

The Manufacturer ID register contains an 8-bit word that identifies novosense as the manufacturer of the NST1412.

5.15. Revision Register

Table 5.20. Revision Register

Write Addr	Read Addr	R/W	Bit7	Bit6	Bit5	Bit4	Bit3	Bit2	Bit1	Bit0	Default	Description
FF	FF	R	0	0	0	0	0	1	0	0	04	Revision

The Revision register contains an 8-bit word that identifies the die revision.

6. Typical Application

6.1. Application Information

The NST1412 device requires only one transistor connected between the DP and DN pins to perform remote temperature measurements. If the remote channel is not used and only the local temperature is measured, hang the DP pin in the air. The SCL, SDA, ALERT, and THERM pins require pull-up resistors to ensure proper communication. A 0.1μF type power supply decoupling capacitor is recommended for local bypass.

6.2. Typical Application

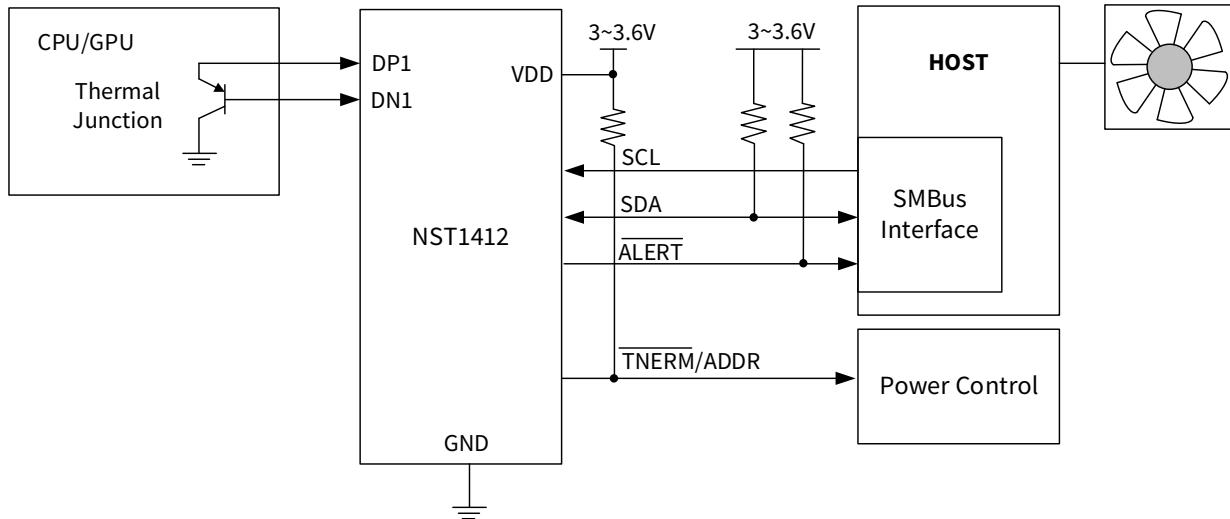

Figure 6.1. NST1412 Basic Connections Using a Discrete Remote Transistor

7. Suggestions for Selection

The following figure shows the full-temperature zone curves of four different types of audion tested in practice. The difference between each type of audion is no more than 0.2°C.

Table 7.1. Suggestions for Selection

NUM	BJT LIST	remote1		remote2	
		Mean	σ	Mean	σ
1	YJ_MMDT3904	0.03748	0.33767	-0.03476	0.27146
2	ON_MMBT3904	-0.04314	0.33428	-0.11192	0.29876
3	LRC_LMBT3904LT1G	0.01058	0.34926	-0.05246	0.270357
4	DIODES_MMBT3904	-0.03147	0.33829	-0.11533	0.264984

8. PCB Layout

Board applications are often in places where the environment is relatively noisy. In order to avoid the adverse impact of environmental noise on products, the following points need to be paid attention to:

1. Place the temperature measuring diode as close to NST1412 as possible to avoid the influence of noise sources such as clock signal during the wiring process.
2. DP+ and DP- should be arranged as parallel as possible, and there should be enough shielding layer beside them to resist external interference.
3. Minimize the holes and solder joints in DP+ and DP- wiring.
4. Place a decoupling capacitor with a capacity of 0.1uF next to VDD.
5. If you are in an application place with high environmental noise, you can add a capacitor with a maximum of 2000pF between DP+ and DP- to reduce the impact of environmental noise.

9. Package Information

MSOP(8) PACKAGE

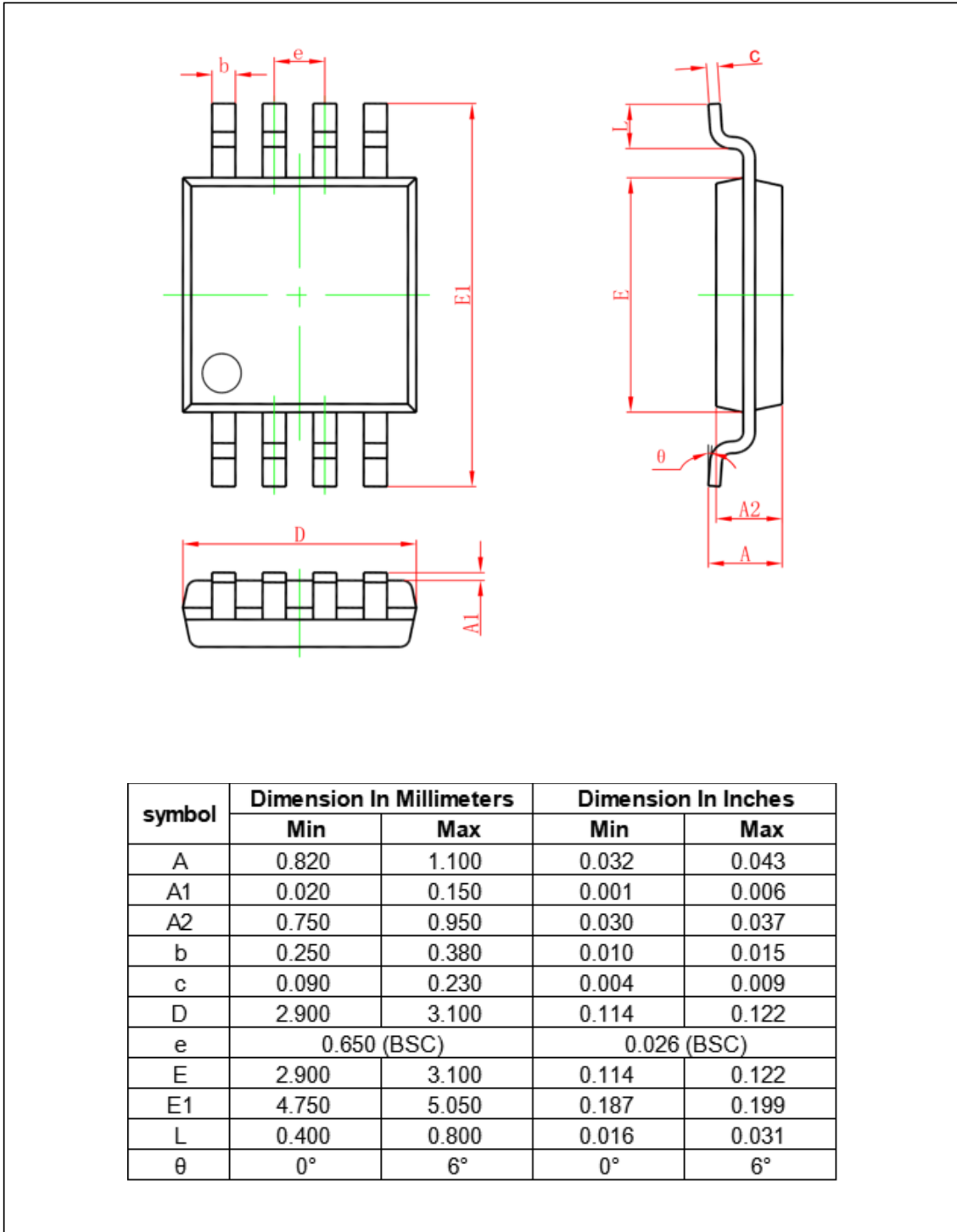

10. Land Pattern

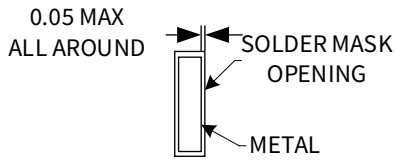
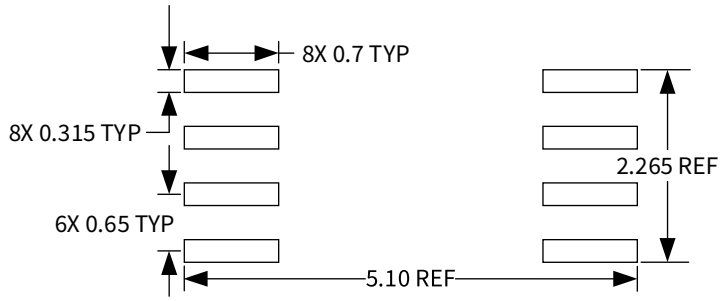

NON SOLDER MASK DEFINED

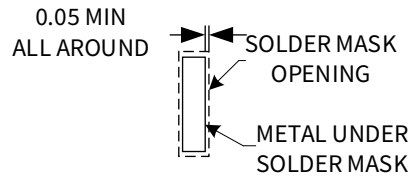

SOLDER MASK DEFINED

Unit: mm

11. Tape and Reel Information

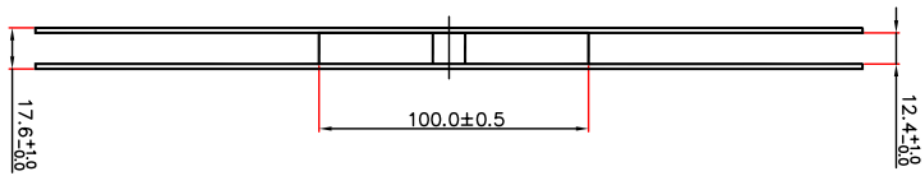
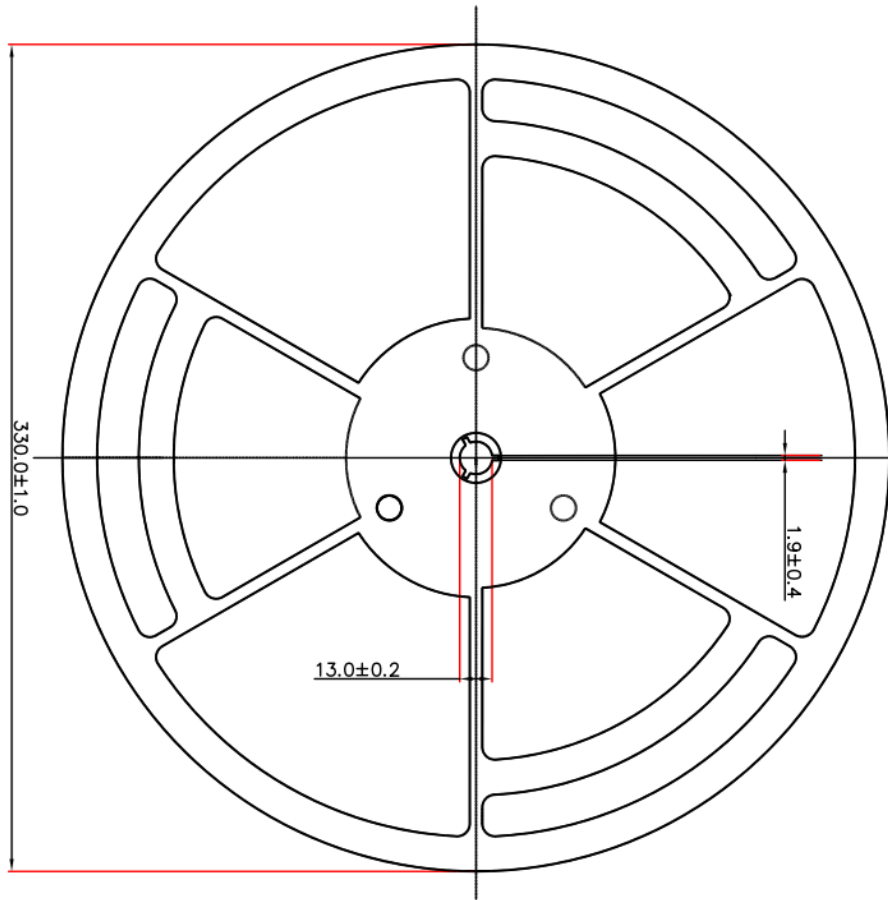

REEL Information (in mm)

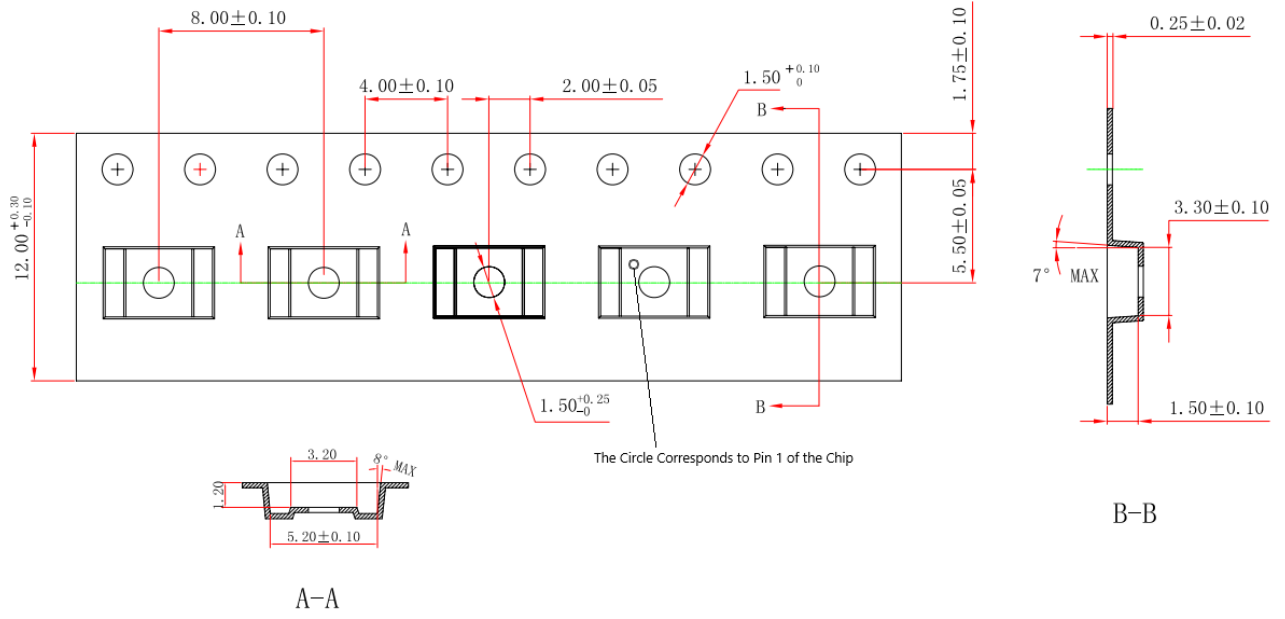

MSOP (8) TAPE Information (in mm)

13. Order Information

Type	Unit	Marking	Description
NST1412-DMSR	4000ea/Reel	T1412 XXXXXX	MSOP-8 package, Reel

NOTE: All packages are RoHS-compliant with peak reflow temperatures of 260 °C according to the JEDEC industry standard classifications and peak solder temperatures.

Moisture Sensitivity Level: 2

14. Marking Rule

Type	Line	Marking	Description
NST1412- DMSR MSOP8 4.9X3mm	Line1	T1412	Product model fixed code
	Line2	X	X-Fixed code
		Y	Y- Last of the year
		WW	WW- weekly
	Line3	CC	CC- Order serial number
	Line3	pin1 & logo	pin1 & logo

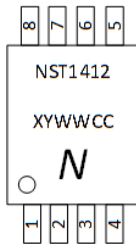

15. Revision History

Revision	Description	Date
0.1	Initial Version	2022/9/13
0.2	Add pcb layout and update specification	2022/12/02
0.3	Update description information	2022/12/14
1.0	Add marking rule information	2023/1/28
1.1	Updated some application descriptions	2023/6/30

IMPORTANT NOTICE

The information given in this document (the “Document”) shall in no event be regarded as any warranty or authorization of, express or implied, including but not limited to accuracy, completeness, merchantability, fitness for a particular purpose or infringement of any third party’s intellectual property rights.

Users of this Document shall be solely responsible for the use of NOVOSENSE’s products and applications, and for the safety thereof. Users shall comply with all laws, regulations and requirements related to NOVOSENSE’s products and applications, although information or support related to any application may still be provided by NOVOSENSE.

This Document is provided on an “AS IS” basis, and is intended only for skilled developers designing with NOVOSENSE’ products. NOVOSENSE reserves the rights to make corrections, modifications, enhancements, improvements or other changes to the products and services provided without notice. NOVOSENSE authorizes users to use this Document exclusively for the development of relevant applications or systems designed to integrate NOVOSENSE’s products. No license to any intellectual property rights of NOVOSENSE is granted by implication or otherwise. Using this Document for any other purpose, or any unauthorized reproduction or display of this Document is strictly prohibited. In no event shall NOVOSENSE be liable for any claims, damages, costs, losses or liabilities arising out of or in connection with this Document or the use of this Document.

For further information on applications, products and technologies, please contact NOVOSENSE (www.novosns.com).

Suzhou NOVOSENSE Microelectronics Co., Ltd