



PROPRIETARY NOTE

THIS SPECIFICATION IS THE PROPERTY OF BOE CQ AND SHALL NOT BE REPRODUCED OR COPIED WITHOUT THE WRITTEN PERMISSION OF BOE CQ AND MUST BE RETURNED TO BOE CQ UPON ITS REQUEST

1

TITLE : NT156FHM-N41

Product Specification

Rev. O

Chongqing BOE Optoelectronics Technology Co., Ltd

SPEC. NUMBER	PRODUCT GROUP TFT-LCD	Rev. O	ISSUE DATE 2015.09.02	PAGE 1 OF 32
--------------	--------------------------	-----------	--------------------------	-----------------



PRODUCT GROUP

REV

ISSUE DATE

Customer SPEC

Rev. 0

2015.09.02

REVISION HISTORY

preliminary specification

Final specification

Revision No.	Page	Description of changes	Date	Prepared
PO	32	Initial Release	2015.09.02	胡伟

SPEC. NUMBER	SPEC. TITLE	PAGE
B2014-Q011-O (2/3)	NT156FHM-N41 Product Specification Rev. 0	2 OF 32

Contents

No.	Items	Page
1.0	General Description	4
2.0	Absolute Maximum ratings	6
3.0	Electrical specifications.	7
4.0	Optical specifications.	9
5.0	Interface Connection	14
6.0	Signal Timing Specification	17
7.0	Input Signals, Display Colors & Gray Scale of Colors	19
8.0	Power Sequence	20
9.0	Connector description	21
10.0	Mechanical Characteristics	25
11.0	Reliability Test	23
12.0	Handling & Cautions.	23
13.0	Label	24
14.0	Packing information	26
15.0	Mechanical Outline Dimension	27
16.0	EDID Table	29

1.0 GENERAL DESCRIPTION

1.1 Introduction

NT156FHM-N41 is a color active matrix TFT LCD module using amorphous silicon TFT's (Thin Film Transistors) as an active switching devices. This module has a 15.6 inch diagonally measured active area with Full-HD resolutions (1920 horizontal by 1080 vertical pixel array). Each pixel is divided into RED, GREEN, BLUE dots which are arranged in vertical Stripe and this module is 6-bit+Hi-FRC color depth . The TFT-LCD panel used for this module is a low reflection and higher color type. Therefore, this module is suitable for Notebook PC. The LED Driver for back-light driving is built in this model. All input signals are eDP1.2 interface compatible.

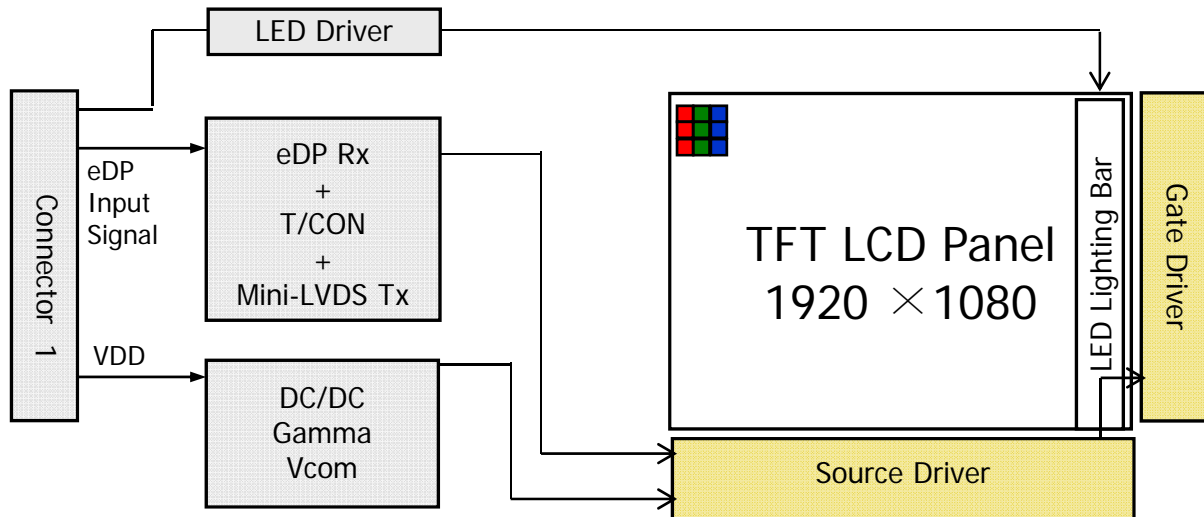

1.2 Features

- 2 lane eDP Interface with 2.7Gbps Link Rates
- Thin and light weight
- 6-bit +Hi-FRC color depth
- Single LED Lighting Bar. (Bottom side/Horizontal Direction)
- Data enable signal mode
- Side Mounting Frame
- Green Product (RoHS & Halogen free product)
- On board LED Driving circuit
- Low driving voltage and low power consumption
- On board EDID chip

1.3 Application

- Notebook PC (Wide type)

1.4 General Specification

The followings are general specifications at the model NT156FHM-N41. (listed in Table 1.)

<Table 1. General Specifications>

Parameter	Specification	Unit	Remarks
Active area	344.16(H) × 193.59(V)	mm	
Number of pixels	1920 (H) × 1080 (V)	pixels	
Pixel pitch	0.17925(H) × 0.17925(V)	mm	
Pixel arrangement	RGB Vertical stripe		
Display colors	6bit +Hi-FRC		
Display mode	Normally White		
Dimensional outline	359.5 (H) × 206.5(V) × 3.2 (D:max)	mm	
Weight	370(max)	g	
Surface treatment	Anti Glare		
Back-light	Bottom edge side, 1-LED Lighting Bar type		Note 1
Power consumption	P_D : 0.7	W	Note 2
	P_{BL} : 2.6	W	
	P_{total} : 3.3	W	

Notes : 1. LED Lighting Bar (36*LED Array)

Notes: 2. Maximum Measurement Condition :Mosaic Pattern

2.0 ABSOLUTE MAXIMUM RATINGS

The followings are maximum values which, if exceed, may cause faulty operation or damage to the unit. The operational and non-operational maximum voltage and current values are listed in Table 2.

< Table 2. Absolute Maximum Ratings >

Ta=25+/-2°C

Parameter	Symbol	Min.	Max.	Unit	Remarks
Power Supply Voltage	V _{DD}	-0.3	4.0	V	Note 1
Logic Supply Voltage	V _{IN}	V _{SS} -0.3	V _{DD} +0.3	V	
Operating Temperature	T _{OP}	0	+50	°C	Note 2
Storage Temperature	T _{ST}	-20	+60	°C	

- Notes : 1. Permanent damage to the device may occur if maximum values are exceeded functional operation should be restricted to the condition described under normal operating conditions.
2. Temperature and relative humidity range are shown in the figure below.
 95 % RH Max. (40 °C ≥ Ta)
 Maximum wet - bulb temperature at 39 °C or less. (Ta > 40 °C) No condensation.

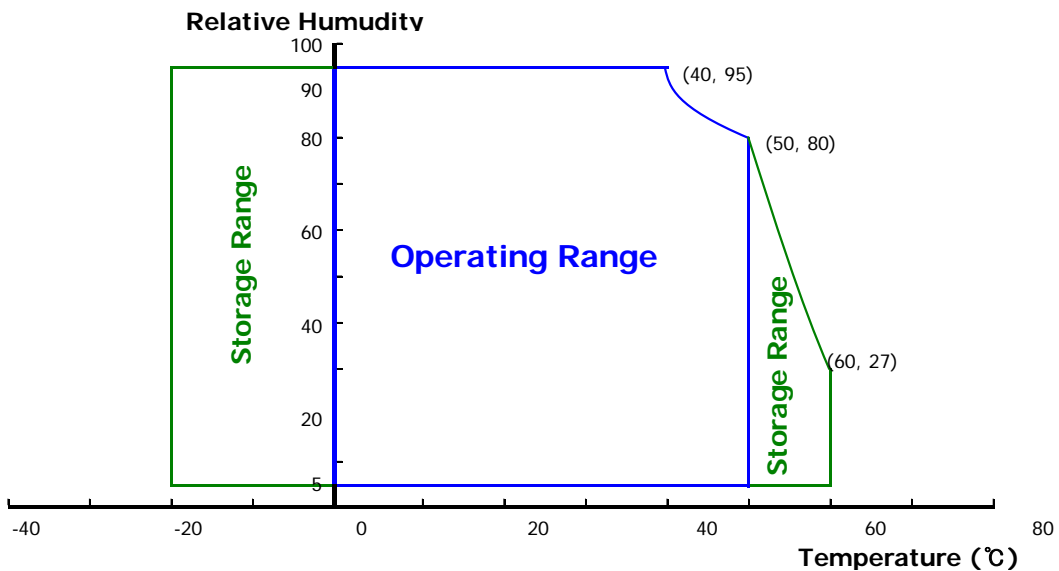

3.0 ELECTRICAL SPECIFICATIONS

3.1 Electrical Specifications

< Table 3. Electrical specifications >

Ta=25+/-2°C

Parameter		Min.	Typ.	Max.	Unit	Remarks
Power Supply Voltage	V _{DD}	3.0	3.3	3.6	V	Note 1
Permissible Input Ripple Voltage	V _{RF}	-	-	100	mV	At V _{DD} = 3.3V
Power Supply Current	I _{DD}	-	210	500	mA	Note 1
Positive-going Input Threshold Voltage	V _{IT+}	-	-	100	mV	V _{cm} = 1.2V typ.
Negative-going Input Threshold Voltage	V _{IT-}	-100	-	-	mV	
Differential Input Voltage	V _{ID}	200	-	600	mV	
Power Consumption	P _D	-	0.7	1.65	W	Note 1
	P _{BL}	-		2.6	W	Note 2
	P _{total}	-		4.25	W	

Notes : 1. The supply voltage is measured and specified at the interface connector of LCM.

The current draw and power consumption specified is for 3.3V at 25°C.

a) Typ : Mosaic Pattern 8*8

b) Max : skip subpixel 255

2. Calculated value for reference (V_{LED} × I_{LED})

3.2 Backlight Unit

< Table 4. LED Driving guideline specifications >

Ta=25+/-2°C

Parameter		Min.	Typ.	Max.	Unit	Remarks
LED Forward Voltage	V _F	-	-	3.0	V	-
LED Forward Current	I _F	-	20.3		mA	-
LED Power Consumption	P _{LED}		-	2.6	W	Note 1
LED Life-Time	N/A	15,000	-	-	Hour	I _F = 20.3mA
Power supply voltage for LED Driver	V _{LED}	5	12	20	V	
EN Control Level	Backlight on	2.5		5.0	V	
	Backlight off	0		1.0	V	
PWM Control Level	PWM High Level	2.5		5.0	V	
	PWM Low Level	0		0.1	V	
PWM Control Frequency	F _{PWM}	200	-	10,000	Hz	
Duty Ratio	-	1	-	100	%	Note3

Notes : 1. Power supply voltage 12V for LED Driver,

Calculator Value for reference $I_F \times V_F \times 36 / \text{Driver efficiency} = P_{LED}$

2. The LED Life-time define as the estimated time to 50% degradation of initial luminous.

3. 1% duty cycle is achievable with a dimming frequency less than 1KHz.

4.0 OPTICAL SPECIFICATION

4.1 Overview

The test of Optical specifications shall be measured in a dark room (ambient luminance ≤ 1 lux and temperature = $25 \pm 2^\circ\text{C}$) with the equipment of Luminance meter system (Goniometer system and TOPCON BM-5) and test unit shall be located at an approximate distance 50cm from the LCD surface at a viewing angle of θ and Φ equal to 0° . We refer to $\theta\Phi=0$ ($=\theta_3$) as the 3 o'clock direction (the "right"), $\theta\Phi=90$ ($=\theta_{12}$) as the 12 o'clock direction ("upward"), $\theta\Phi=180$ ($=\theta_9$) as the 9 o'clock direction ("left") and $\theta\Phi=270$ ($=\theta_6$) as the 6 o'clock direction ("bottom"). While scanning θ and/or Φ , the center of the measuring spot on the Display surface shall stay fixed. The backlight should be operating for 30 minutes prior to measurement. VDD shall be $3.3 \pm 0.3\text{V}$ at 25°C . Optimum viewing angle direction is 6 o'clock.

4.2 Optical Specifications

<Table 5. Optical Specifications>

Parameter		Symbol	Condition	Min.	Typ.	Max.	Unit	Remark
Viewing Angle range	Horizontal	Θ_3	CR > 10	40	45	-	Deg.	Note 1
		Θ_9		40	45	-	Deg.	
	Vertical	Θ_{12}		15	20	-	Deg.	
		Θ_6		30	40	-	Deg.	
Luminance Contrast ratio		CR	$\Theta = 0^\circ$	400	500			Note 2
Luminance of White	5 Points	Y_w	$\Theta = 0^\circ$ $I_{LED} = 21\text{mA}$	187	220	-	cd/m ²	Note 3
White Luminance uniformity	5 Points	ΔY_5		80	-	-		Note 4
	13 Points	ΔY_{13}		60	-	-		
White Chromaticity		x_w	$\Theta = 0^\circ$	0.283	0.313	0.343		Note 5
		y_w		0.299	0.329	0.359		
Reproduction of color	Red	x_R	$\Theta = 0^\circ$	-0.03	0.590	+0.03		
		y_R			0.350			
	Green	x_G			0.330			
		y_G			0.555			
	Blue	x_B			0.153			
		y_B			0.119			
Response Time (Rising + Falling)		T_{RT}	$T_a = 25^\circ\text{C}$ $\Theta = 0^\circ$	-	12	16	ms	Note 6
Cross Talk		CT	$\Theta = 0^\circ$	-	-	2.0	%	Note 7

BOE	PRODUCT GROUP	REV	ISSUE DATE
	Customer SPEC	Rev. O	2015.09.02

Notes :

1. Viewing angle is the angle at which the contrast ratio is greater than 10. The viewing angles are determined for the horizontal or 3, 9 o'clock direction and the vertical or 6, 12 o'clock direction with respect to the optical axis which is normal to the LCD surface (see FIGURE 1).

2. Contrast measurements shall be made at viewing angle of $\Theta = 0$ and at the center of the LCD surface. Luminance shall be measured with all pixels in the view field set first to white, then to the dark (black) state .

(see FIGURE 1) Luminance Contrast Ratio (CR) is defined mathematically.

$$CR = \frac{\text{Luminance when displaying a white raster}}{\text{Luminance when displaying a black raster}}$$

3. Center Luminance of white is defined as luminance values of 5 point average across the LCD surface. Luminance shall be measured with all pixels in the view field set first to white. This measurement shall be taken at the locations shown in FIGURE 2 for a total of the measurements per display.

4. The White luminance uniformity on LCD surface is then expressed as : $\Delta Y = \text{Minimum Luminance of 5(or 13) points} / \text{Maximum Luminance of 5(or 13) points}$.

(see FIGURE 2 and FIGURE 3).

5. The color chromaticity coordinates specified in Table 5 shall be calculated from the spectral data measured with all pixels first in red, green, blue and white. Measurements shall be made at the center of the panel.

6. The electro-optical response time measurements shall be made as FIGURE 4 by switching the "data" input signal ON and OFF. The times needed for the luminance to change from 10% to 90% is T_r , and 90% to 10% is T_d .

7. Cross-Talk of one area of the LCD surface by another shall be measured by comparing the luminance (Y_A) of a 25mm diameter area, with all display pixels set to a gray level, to the luminance (Y_B) of that same area when any adjacent area is driven dark.

(See FIGURE 5).

SPEC. NUMBER	SPEC. TITLE	PAGE
B2014-Q011-O (3/3)	NT156FHM-N41 Product Specification Rev. O	10 OF 32

4.3 Optical measurements

Figure 1. Measurement Set Up

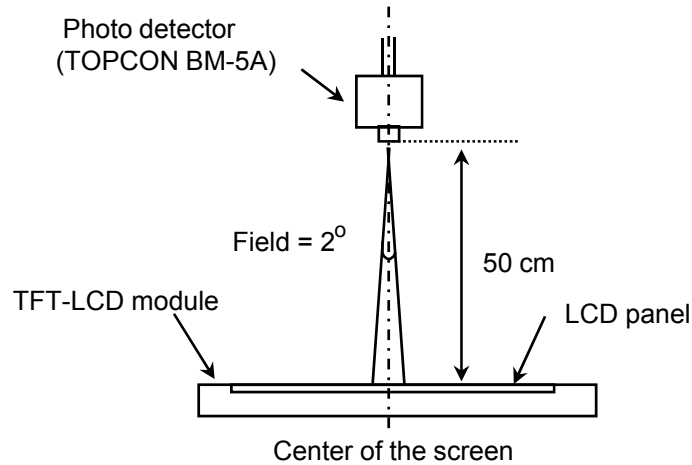

Optical characteristics measurement setup

Figure 2. White Luminance and Uniformity Measurement Locations (5 points)

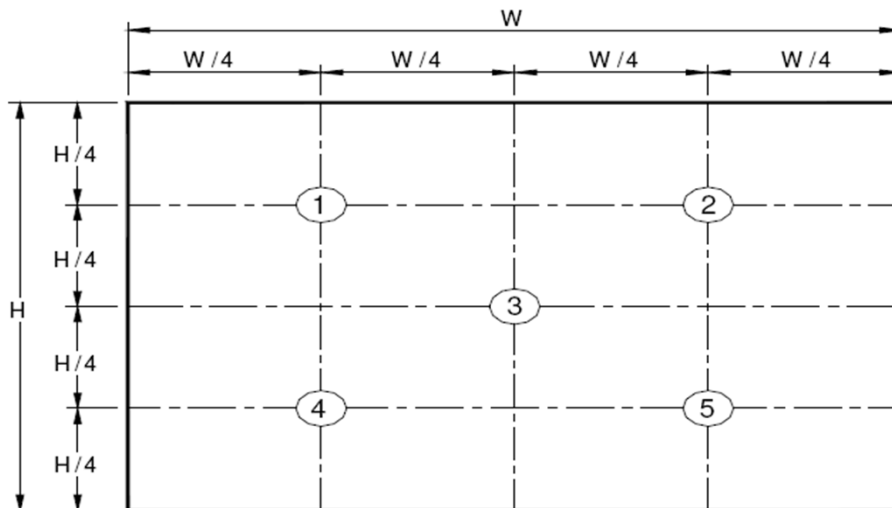

Center Luminance of white is defined as luminance values of center 5 points across the LCD surface. Luminance shall be measured with all pixels in the view field set first to white. This measurement shall be taken at the locations shown in FIGURE 2 for a total of the measurements per display.

Figure 3. Uniformity Measurement Locations (13 points)

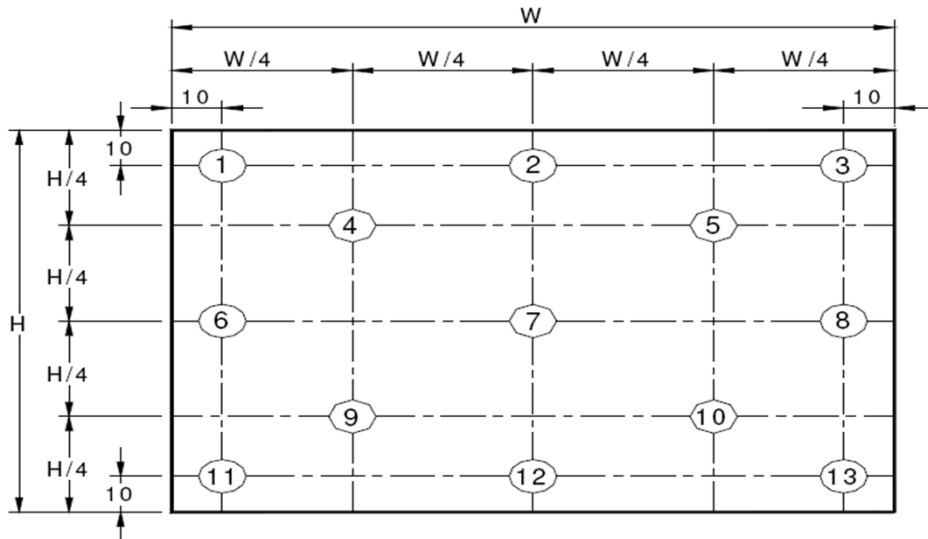

The White luminance uniformity on LCD surface is then expressed as : $\Delta Y5 = \text{Minimum Luminance of five points} / \text{Maximum Luminance of five points}$ (see FIGURE 2) , $\Delta Y13 = \text{Minimum Luminance of 13 points} / \text{Maximum Luminance of 13 points}$ (see FIGURE 3).

Figure 4. Response Time Testing

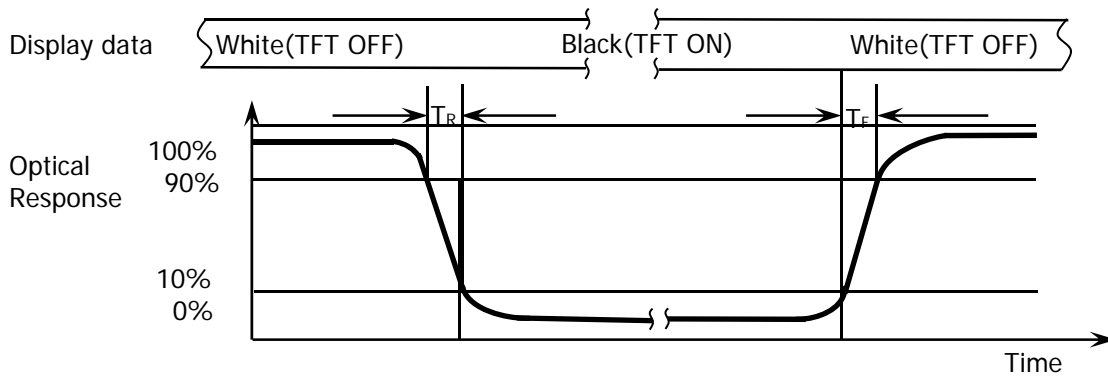

The electro-optical response time measurements shall be made as shown in FIGURE 4 by switching the “data” input signal ON and OFF. The times needed for the luminance to change from 10% to 90% is T_d and 90% to 10% is T_r .

SPEC. NUMBER	SPEC. TITLE	PAGE
	NT156FHM-N41 Product Specification Rev. O	12 OF 32

Figure 5. Cross Modulation Test Description

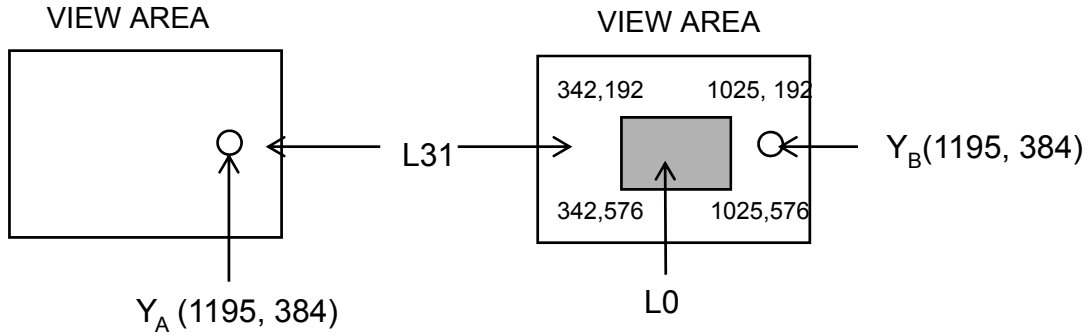

$$\text{Cross-Talk (\%)} = \left| \frac{Y_B - Y_A}{Y_A} \right| \times 100$$

Where:

Y_A = Initial luminance of measured area (cd/m²)

Y_B = Subsequent luminance of measured area (cd/m²)

The location measured will be exactly the same in both patterns

Cross-Talk of one area of the LCD surface by another shall be measured by comparing the luminance (Y_A) of a 25mm diameter area, with all display pixels set to a gray level, to the luminance (Y_B) of that same area when any adjacent area is driven dark (Refer to FIGURE 5).

5.0 INTERFACE CONNECTION.

5.1 Electrical Interface Connection

The electronics interface connector is UJU IS050-L30B-C10 or Compatible.
The connector interface pin assignments are listed in Table 6.

<Table 6. Pin Assignments for the Interface Connector>

Terminal	Symbol	Functions
Pin No.	Symbol	Description
1	NC	No Connection
2	H_GND	Ground
3	LANE1_N	eDP RX channel 1 negative
4	LANE1_P	eDP RX channel 1 positive
5	H_GND	Ground
6	LANE0_N	eDP RX channel 0 negative
7	LANE0_P	eDP RX channel 0 positive
8	H_GND	Ground
9	AUX_CH_P	eDP AUX CH positive
10	AUX_CH_N	eDP AUX CH negative
11	H_GND	Ground
12	LCD_VCC	Power Supply, 3.3V (typ.)
13	LCD_VCC	Power Supply, 3.3V (typ.)
14	LCD_Self_Test	Panel self test enable
15	H_GND	Ground
16	H_GND	Ground
17	HPD	Hot plug detect output
18	BL_GND	LED Ground
19	BL_GND	LED Ground
20	BL_GND	LED Ground
21	BL_GND	LED Ground
22	BL_ENABLE	LED enable pin(+3.3V Input)
23	BL_PWM	System PWM Signal Input
24	NC	Reserved for LCD manufacturer's use
25	NC	Reserved for LCD manufacturer's use
26	BL_POWER	LED Power Supply 5V-21V
27	BL_POWER	LED Power Supply 5V-21V
28	BL_POWER	LED Power Supply 5V-21V
29	BL_POWER	LED Power Supply 5V-21V
30	NC	No Connection

5-2. eDP Interface

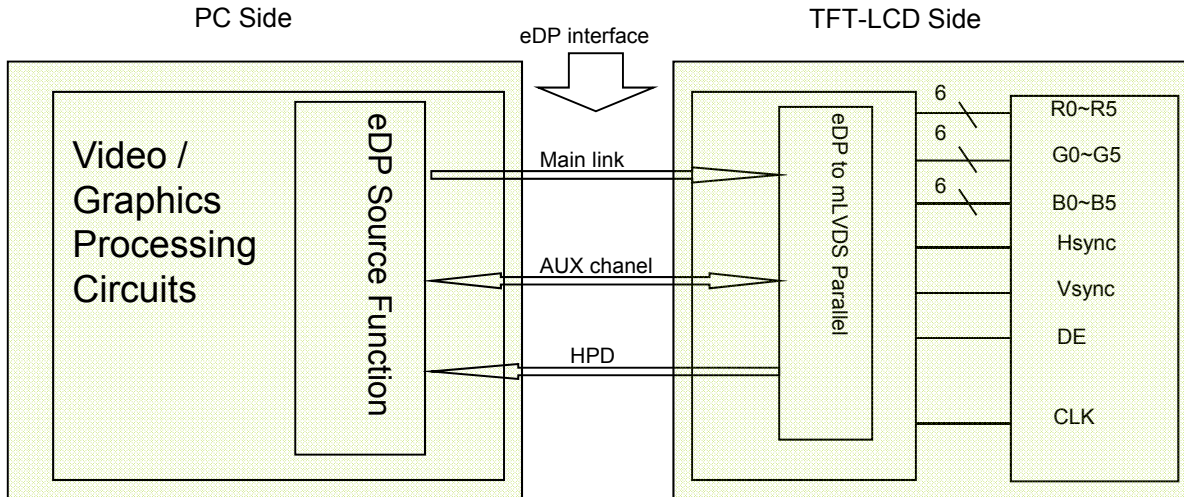

Note. Transmitter : Parade DP501or equivalent.
 Transmitter is not contained in Module.

5.3 Data Input Format

<Table 6. Pin Assignments for the Interface Connector>

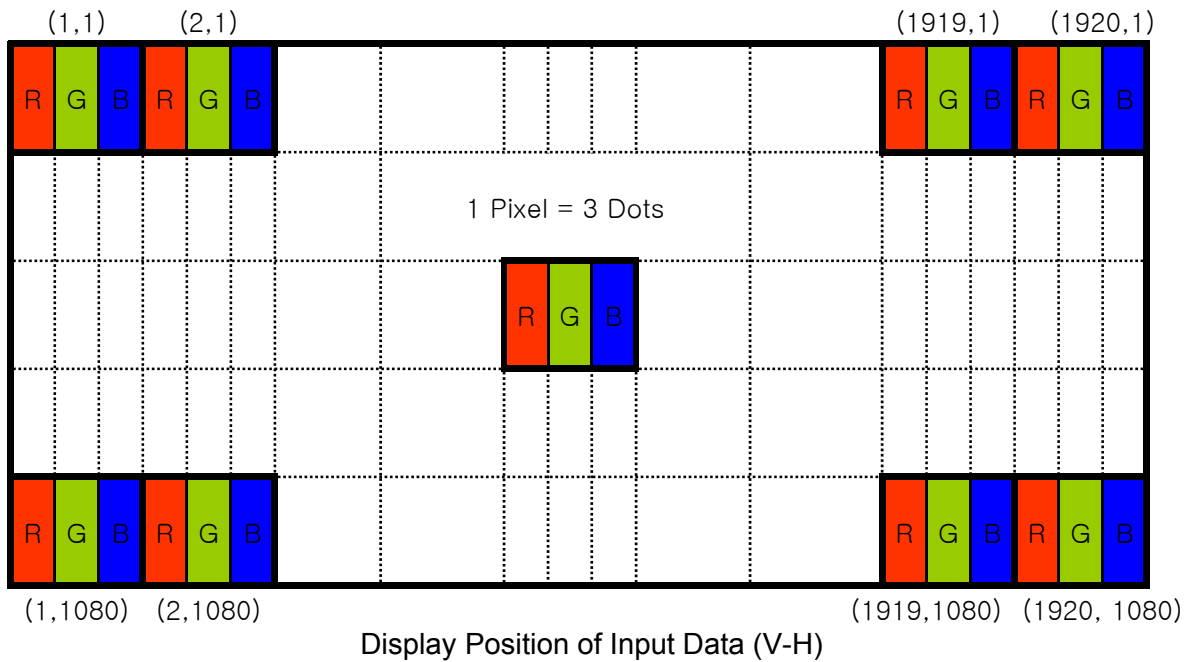

6.0 SIGNAL TIMING SPECIFICATION

6.1 The NT156FHM-N41 is operated by the DE only.

Item		Symbols	Min	Typ	Max	Unit
Clock	Frequency	1/Tc	100	153.6	160.0	MHz
	High Time	Tch	-	4/7Tc	-	Tc
	Low Time	Tcl	-	3/7Tc	-	Tc
Frame Period		Tv	1090	1160	1180	lines
			40	60	62	Hz
			25	16.67	16.13	ms
Vertical Display Period		Tvd	-	1080	-	lines
One line Scanning Period		Th	2080	2207	2260	clocks
Horizontal Display Period		Thd	-	1920	-	clocks

6.2 eDP Rx Interface Timing Parameter

The specification of the eDP Rx interface timing parameter is shown in Table 8.

<Table 8. eDP Rx Interface Timing Specification>

Item	Symbol	Min	Typ	Max	Unit	Remark
Spread spectrum clock	ssc		0.5		%	
Differential peak-to-peak input voltage at package pins	VRX-DIFFp-p	100	0	1320	mV	
Rx input DC common mode voltage	VRX_DC_CM	-	GND	-	V	
Differential termination resistance	RRX-DIFF	80	-	100	Ω	
Single-ended termination resistance	RRX-SE	40	-	60	Ω	
Rx short circuit current limit	IRX_SHORT	-	-	20	mA	
Intra-pair skew at Rx package pins (HBR) RX intra-pair skew tolerance at HBR	LRX_SKEW_INTRA_PAIR	-	-	150	ps	

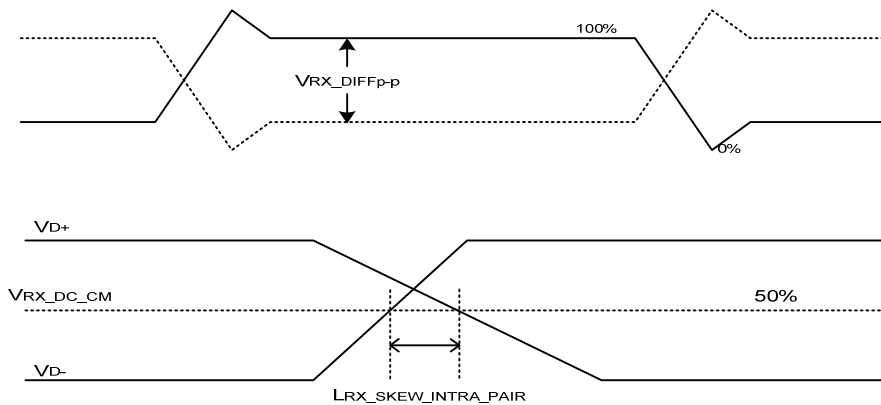

7.0 INPUT SIGNALS, BASIC DISPLAY COLORS & GRAY SCALE OF COLORS

	Colors & Gray scale	Data signal																	
		R0	R1	R2	R3	R4	R5	G0	G1	G2	G3	G4	G5	B0	B1	B2	B3	B4	B5
Basic colors	Black	0	0	0	0	0	0	0	0	0	0	0	0	0	0	0	0	0	0
	Blue	0	0	0	0	0	0	0	0	0	0	0	0	1	1	1	1	1	1
	Green	0	0	0	0	0	0	1	1	1	1	1	1	0	0	0	0	0	0
	Light Blue	0	0	0	0	0	0	1	1	1	1	1	1	1	1	1	1	1	1
	Red	1	1	1	1	1	1	0	0	0	0	0	0	0	0	0	0	0	0
	Purple	1	1	1	1	1	1	0	0	0	0	0	0	1	1	1	1	1	1
	Yellow	1	1	1	1	1	1	1	1	1	1	1	1	0	0	0	0	0	0
	White	1	1	1	1	1	1	1	1	1	1	1	1	1	1	1	1	1	1
Gray scale of Red	Black	0	0	0	0	0	0	0	0	0	0	0	0	0	0	0	0	0	0
	△	1	0	0	0	0	0	0	0	0	0	0	0	0	0	0	0	0	0
	Darker	0	1	0	0	0	0	0	0	0	0	0	0	0	0	0	0	0	0
	△																		
	▽																		
	Brighter	1	0	1	1	1	1	0	0	0	0	0	0	0	0	0	0	0	0
	▽	0	1	1	1	1	1	0	0	0	0	0	0	0	0	0	0	0	0
Red	1	1	1	1	1	1	0	0	0	0	0	0	0	0	0	0	0	0	
Gray scale of Green	Black	0	0	0	0	0	0	0	0	0	0	0	0	0	0	0	0	0	0
	△	0	0	0	0	0	0	1	0	0	0	0	0	0	0	0	0	0	0
	Darker	0	0	0	0	0	0	0	1	0	0	0	0	0	0	0	0	0	0
	△																		
	▽																		
	Brighter	0	0	0	0	0	0	1	0	1	1	1	1	0	0	0	0	0	0
	▽	0	0	0	0	0	0	0	1	1	1	1	1	0	0	0	0	0	0
Green	0	0	0	0	0	0	1	1	1	1	1	1	0	0	0	0	0	0	
Gray scale of Blue	Black	0	0	0	0	0	0	0	0	0	0	0	0	0	0	0	0	0	0
	△	0	0	0	0	0	0	0	0	0	0	0	0	1	0	0	0	0	0
	Darker	0	0	0	0	0	0	0	0	0	0	0	0	0	1	0	0	0	0
	△																		
	▽																		
	Brighter	0	0	0	0	0	0	0	0	0	0	0	0	1	0	1	1	1	1
	▽	0	0	0	0	0	0	0	0	0	0	0	0	0	1	1	1	1	1
Blue	0	0	0	0	0	0	0	0	0	0	0	0	1	1	1	1	1	1	
Gray scale of White & Black	Black	0	0	0	0	0	0	0	0	0	0	0	0	0	0	0	0	0	0
	△	1	0	0	0	0	0	1	0	0	0	0	0	1	0	0	0	0	0
	Darker	0	1	0	0	0	0	0	1	0	0	0	0	0	1	0	0	0	0
	△																		
	▽																		
	Brighter	1	0	1	1	1	1	1	0	1	1	1	1	1	0	1	1	1	1
	▽	0	1	1	1	1	1	0	1	1	1	1	1	0	1	1	1	1	1
White	1	1	1	1	1	1	1	1	1	1	1	1	1	1	1	1	1	1	

8.0 POWER SEQUENCE

To prevent a latch-up or DC operation of the LCD module, the power on/off sequence shall be as shown in below

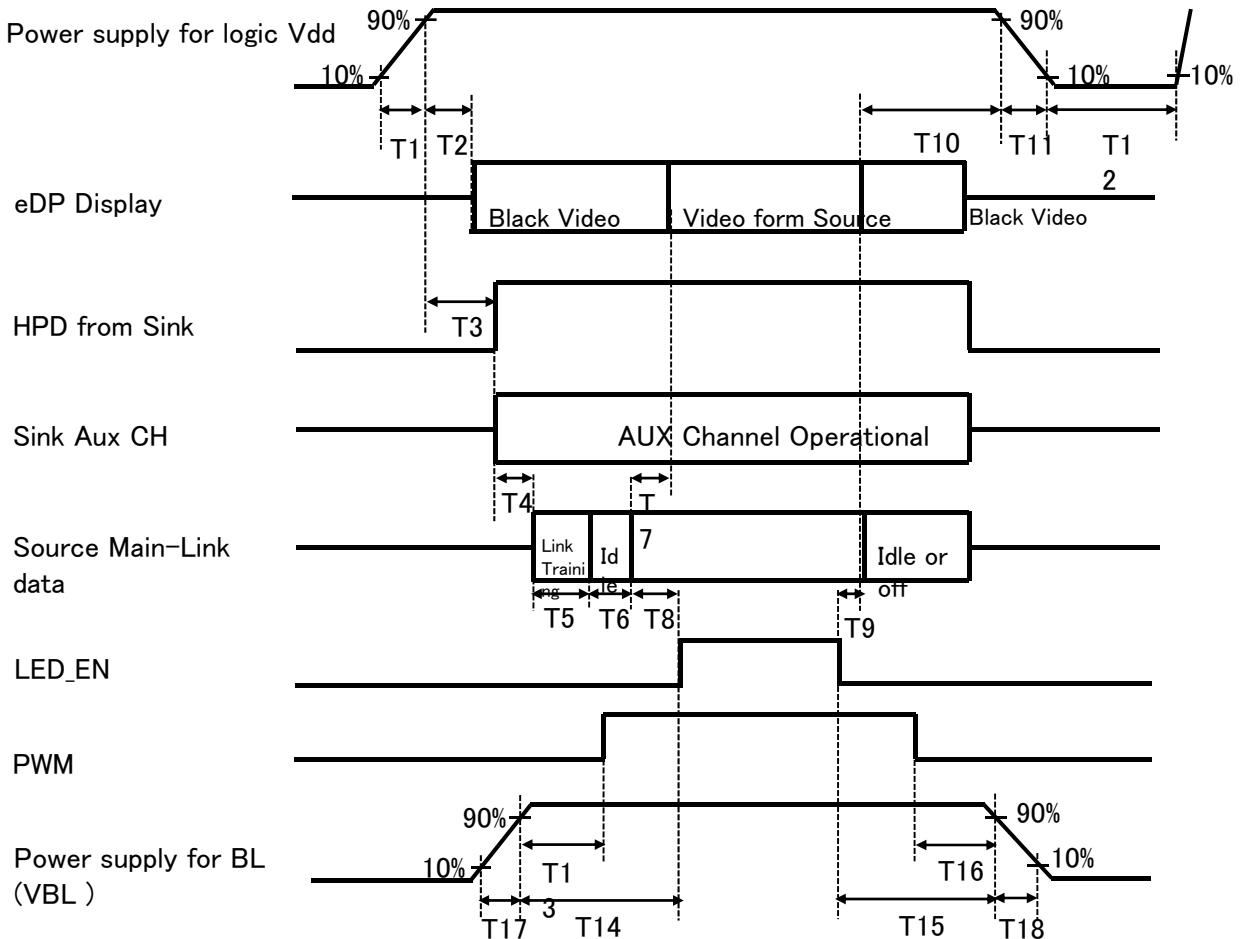

- 0.5ms ≤ T1 ≤ 10 ms
- 0ms ≤ T2 ≤ 200 ms
- 0ms ≤ T3 ≤ 200 ms
- 0ms ≤ T13
- 0ms ≤ T14
- 0ms ≤ T17
- 0ms ≤ T7 ≤ 50ms
- 0ms ≤ T10 ≤ 500 ms
- 0 ms ≤ T11 ≤ 10 ms
- 150ms ≤ T12
- 0ms ≤ T15
- 0ms ≤ T16
- 0ms ≤ T18

Notes:

1. When the power supply VDD is 0V, keep the level of input signals on the low or keep high impedance.
2. Do not keep the interface signal high impedance when power is on. Back Light must be turn on after power for logic and interface signal are valid.

BOE	PRODUCT GROUP	REV	ISSUE DATE
	Customer SPEC	Rev. O	2015.09.02

9.0 Connector Description

Physical interface is described as for the connector on LCM.

These connectors are capable of accommodating the following signals and will be following components.

9.1 TFT LCD Module

Connector Name /Description	For Signal Connector
Manufacturer	STM or Compatible
Type/ Part Number	MSAK24025P30 or Compatible
Mating housing/ Part Number	I-PEX 20454-030T or Compatible

SPEC. NUMBER	SPEC. TITLE	PAGE
B2014-Q011-O (3/3)	NT156FHM-N41 Product Specification Rev. O	21 OF 32

10.0 MECHANICAL CHARACTERISTICS

10.1 Dimensional Requirements

FIGURE 6 shows mechanical outlines for the model NT156FHM-N41.
Other parameters are shown in Table 9.

<Table 9. Dimensional Parameters>

Parameter	Specification	Unit
Active Area	344.16 (H) × 193.59 (V)	
Number of pixels	1920 (H) X 1080 (V) (1 pixel = R + G + B dots)	
Pixel pitch	0.17925 (H) X 0.17925 (V)	
Pixel arrangement	RGB Vertical stripe	
Display colors	6bit+HI-FRC	
Display mode	Normally white	
Dimensional outline	359.5(H)*223.8(V) (W/PCB)*3.2(Max) 359.5 (H)×206.5(V)×3.2 (max)	mm
Weight	370 (max)	gram

10.2 Mounting

See FIGURE 6.

10.3 Anti-Glare and Polarizer Hardness.

The surface of the LCD has an AG coating to minimize reflection and a coating to reduce scratching.

10.4 Light Leakage

There shall not be visible light from the back-lighting system around the edges of the screen as seen from a distance 50cm from the screen with an overhead light level of 350lux.

11.0 RELIABILITY TEST

The Reliability test items and its conditions are shown in below.

<Table 10. Reliability test>

No	Test Items	Conditions
1	High temperature storage test	Ta = 60 °C, 240 hrs
2	Low temperature storage test	Ta = -20 °C, 240 hrs
3	High temperature & high humidity operation test	Ta = 50 °C, 80%RH, 240 hrs
4	High temperature operation test	Ta = 50 °C, 240 hrs
5	Low temperature operation test	Ta = 0 °C, 240 hrs
6	Thermal shock	Ta = -20 °C ↔ 60 °C (0.5 hr), 100 cycle
7	Vibration test (non-operating)	1.5G, 10~500Hz, Half Sine X,Y,Z / Sweep rate : 1 hour
8	Shock test (non-operating)	220G, Half Sine Wave 2msec ±X, ±Y, ±Z Once for each direction
9	Electro-static discharge test (non-operating)	Air : 150 pF, 330Ω, 15 KV Contact : 150 pF, 330Ω, 8 KV

12.0 HANDLING & CAUTIONS

(1) Cautions when taking out the module

- Pick the pouch only, when taking out module from a shipping package.

(2) Cautions for handling the module

- As the electrostatic discharges may break the LCD module, handle the LCD module with care. Peel a protection sheet off from the LCD panel surface as slowly as possible.
- As the LCD panel and back - light element are made from fragile glass material, impulse and pressure to the LCD module should be avoided.
- As the surface of the polarizer is very soft and easily scratched, use a soft dry cloth without chemicals for cleaning.
- Do not pull the interface connector in or out while the LCD module is operating.
- Put the module display side down on a flat horizontal plane.
- Handle connectors and cables with care.

(3) Cautions for the operation

- When the module is operating, do not lose CLK, ENAB signals. If any one of these signals is lost, the LCD panel would be damaged.
- Obey the supply voltage sequence. If wrong sequence is applied, the module would be damaged.

BOE	PRODUCT GROUP	REV	ISSUE DATE
	Customer SPEC	Rev. O	2015.09.02

- (4) Cautions for the atmosphere
- Dew drop atmosphere should be avoided.
 - Do not store and/or operate the LCD module in a high temperature and/or humidity atmosphere. Storage in an electro-conductive polymer packing pouch and under relatively low temperature atmosphere is recommended.
- (5) Cautions for the module characteristics
- Do not apply fixed pattern data signal to the LCD module at product aging.
 - Applying fixed pattern for a long time may cause image sticking.
- (6) Other cautions
- Do not disassemble and/or re-assemble LCD module.
 - Do not re-adjust variable resistor or switch etc.
 - When returning the module for repair or etc., Please pack the module not to be broken. We recommend to use the original shipping packages.

13.0 LABEL

(1) Product label



Module ID Naming Rule:

Digit	1	2	3	4	5	6	7	8	9	10	11	12	13	14	15	16	17
Code	S	L	S	5	1	2	3	5	9	4	2	0	0	0	1	D	B
Description	Model Code /GBN		Grade	Line	Year		Month	Model Extension Code (Last 4 Digits Of FG COD)				Serial No 00001-ZZZZZZ					

SPEC. NUMBER	SPEC. TITLE	PAGE
B2014-Q011-O (3/3)	NT156FHM-N41 Product Specification Rev. O	24 OF 32

BOE	PRODUCT GROUP	REV	ISSUE DATE
	Customer SPEC	Rev. O	2015.09.02

(2) High voltage caution label

	HIGH VOLTAGE CAUTION	COLD CATHODE FLUORESCENT LAMP IN LCD PANEL CONTAINS A SMALL AMOUNT OF MERCURY. PLEASE FOLLOW LOCAL OR- DINANCES OR REGULATIONS FOR DISPOSAL.
	RISK OF ELECTRIC SHOCK, DISCONNECT THE ELECTRIC POWER BEFORE SERVICING	

(3) Box label

BOE		CHONGQING BOE OPTOELECTRONICS TECHNOLOGY Co., LTD	
MODEL: XXXXXXX-XXX	①	Q'TY: XX	②
SERIAL NO: XXXXXXXXXXXXX	③	DATE: XXXXXXXXX	④
BOX ID 条形码			
XXXXXXXXXX	⑤	XXXX	⑥
		XXXX	⑦

序列号标注部分需打印, 说明如下:

1. **FG-CODE(前12位)**
2. **产品数量**
3. **Box ID**
4. **包装日期**
5. **客户端段物料号(客户端)---暂不打印,预留空间**
6. **FG-Code后四位**
7. **供应商代码 ---暂不打印**

Total Size:100×50mm

Digit Code	1	2	3	4	5	6	7	8	9	10	11	12	13
Code	S	L	S	5	1	2	3	D	0	0	0	6	8
Description	Products GBN		Grade	Line	Year		Month	Revisio n Code	SerialNo				

SPEC. NUMBER	SPEC. TITLE	PAGE
	NT156FHM-N41 Product Specification Rev. O	25 OF 32

14.0 PACKING INFORMATION

15.1 Packing order

- Put Pad into the inner box

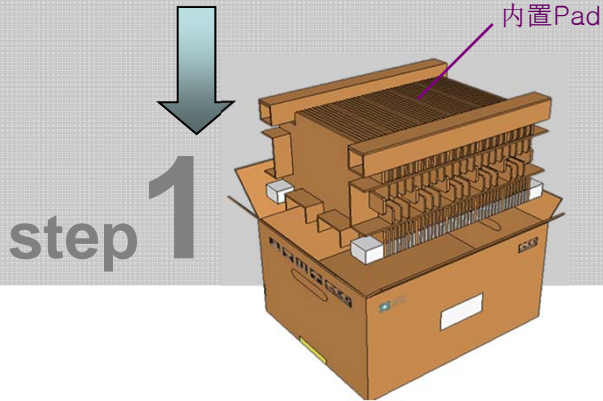

- Put module into the paper spacer and modules bundled by PE Bag

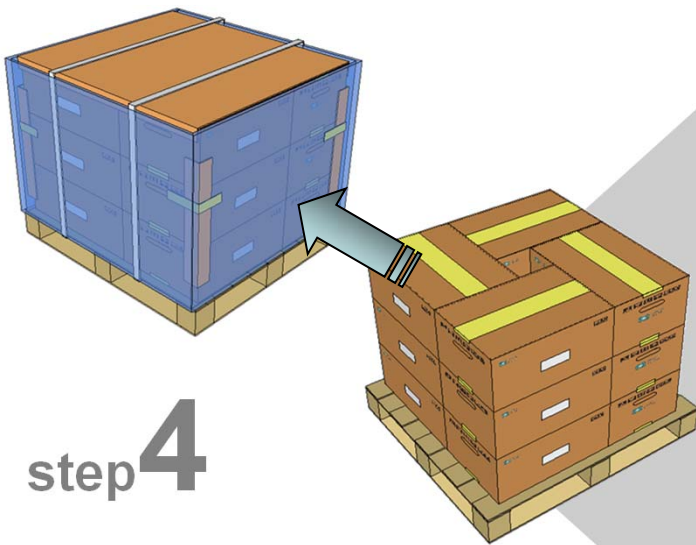
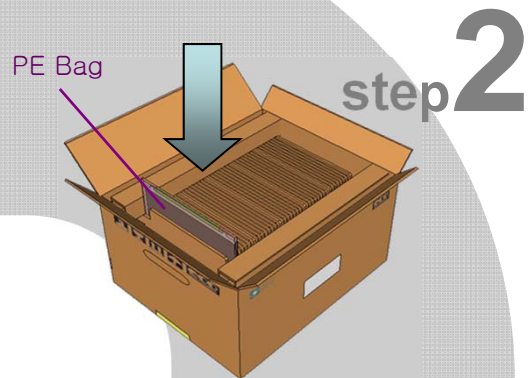

- Put Cover on the top of the pad

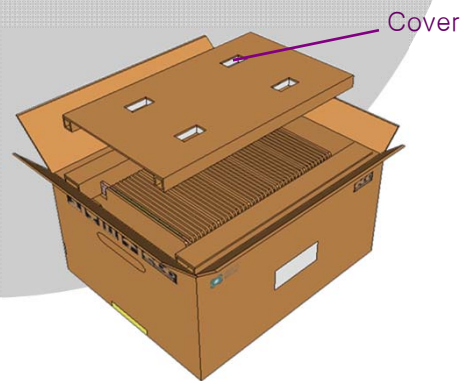

- 12ea Box/Pallet, 456ea MDL/Pallet

15.2 Notes

- Box Dimension:
- Package Quantity in one Box: pcs
- Total Weight: kg

SPEC. NUMBER

SPEC. TITLE

PAGE

NT156FHM-N41 Product Specification Rev. O

26 OF 32

15.0 MECHANICAL OUTLINE DIMENSION

Figure 6. TFT-LCD Module Outline Dimension (Front View)

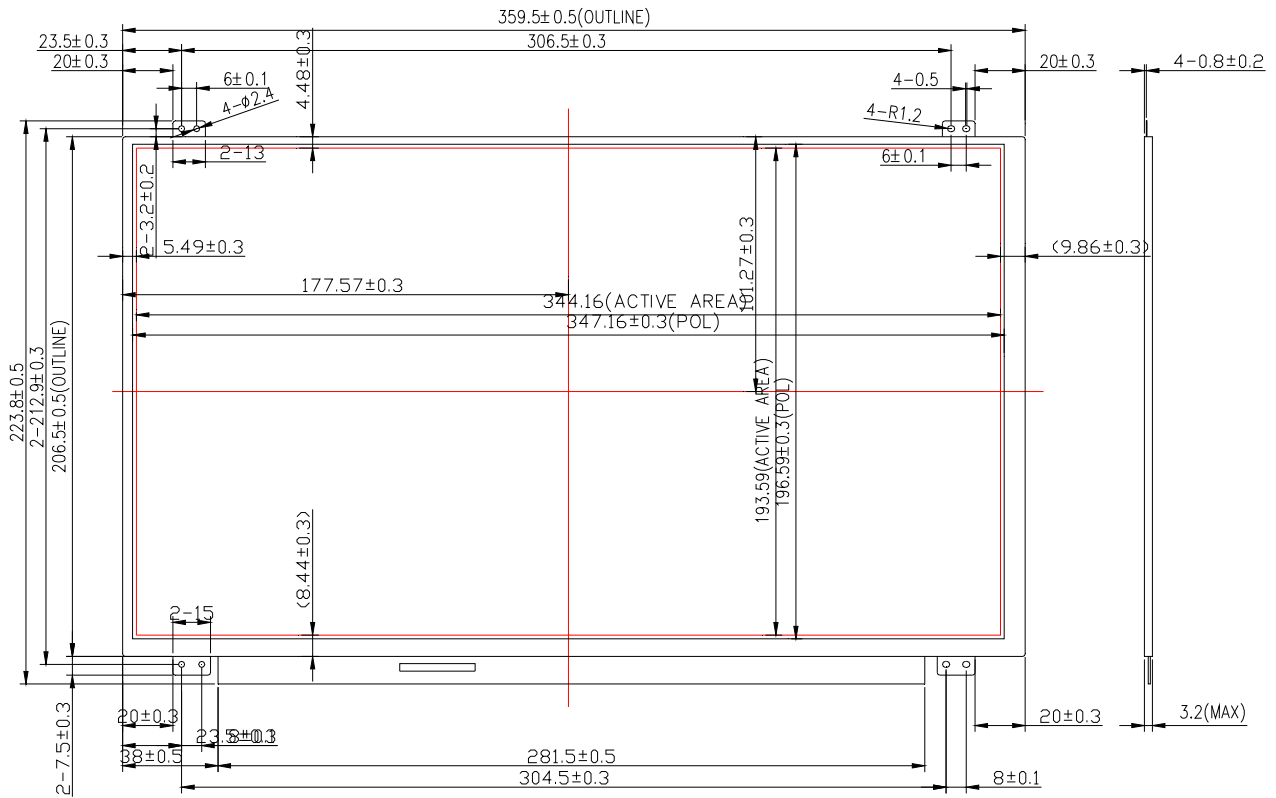
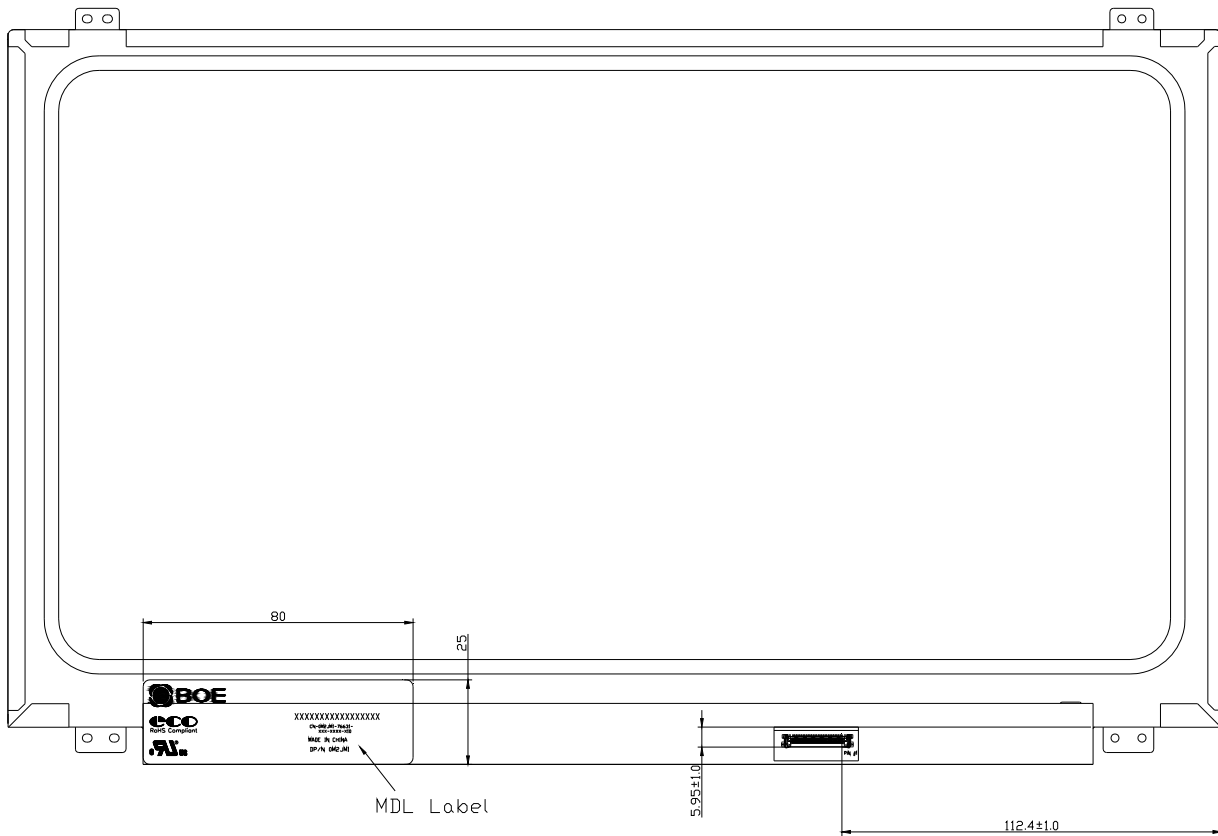

Figure 7. TFT-LCD Module Outline Dimensions (Rear view)



16.0 EDID Table

Addresses (HEX)	Function	Hex	Dec	Crc	Input values	Notes
00	Header	00	0		0	EDID Header
01		FF	255		255	
02		FF	255		255	
03		FF	255		255	
04		FF	255		255	
05		FF	255		255	
06		FF	255		255	
07		00	0		0	
08	ID Manufacturer Name	09	9		BOE	ID = BOE
09		E5	229			
0A	ID Product Code	87	135		1671	ID = 1671
0B		06	6			
0C	32-bit serial No.	00	0			
0D		00	0			
0E		00	0			
0F		00	0			
10	Week of manufacture	01	1		1	
11	Year of Manufacture	19	25		2015	Manufactured in 2015
12	EDID Structure Ver.	01	1		1	EDID Ver 1.0
13	EDID revision #	04	4		4	EDID Rev. 0.4
14	Video input definition	A5	165		-	
15	Max H image size	22	34		34	34 cm (Approx)
16	Max V image size	13	19		19	19 cm (Approx)
17	Display Gamma	78	120		2.2	Gamma curve = 2.2
18	Feature support	02	2			RGB display, Preferred Timming mode
19	Red/Green low bits	B0	176		-	Red / Green Low Bits
1A	Blue/White low bits	90	144		-	Blue / White Low Bits
1B	Red x high bits	97	151	606	0.592	Red (x) = 10010111 (0.592)
1C	Red y high bits	58	88	355	0.347	Red (y) = 01011000 (0.347)
1D	Green x high bits	54	84	336	0.329	Green (x) = 01010100 (0.329)
1E	Green y high bits	92	146	584	0.571	Green (y) = 10010010 (0.571)
1F	Blue x high bits	26	38	154	0.151	Blue (x) = 00100110 (0.151)
20	BLue y high bits	1D	29	117	0.115	Blue (y) = 00011101 (0.115)
21	White x high bits	50	80	320	0.313	White (x) = 01010000 (0.313)
22	White y high bits	54	84	336	0.329	White (y) = 01010100 (0.329)
23	Established timing 1	00	0		-	
24	Established timing 2	00	0		-	



PRODUCT GROUP

REV

ISSUE DATE

Customer SPEC

Rev. O

2015.09.02

25	Established timing 3	00	0			
26	Standard timing #1	01	1			Not Used
27		01	1			
28	Standard timing #2	01	1			Not Used
29		01	1			
2A	Standard timing #3	01	1			Not Used
2B		01	1			
2C	Standard timing #4	01	1			Not Used
2D		01	1			
2E	Standard timing #5	01	1			Not Used
2F		01	1			
30	Standard timing #6	01	1			Not Used
31		01	1			
32	Standard timing #7	01	1			Not Used
33		01	1			
34	Standard timing #8	01	1			Not Used
35		01	1			
36	Detailed timing/monitor descriptor #1	00	0		153.6	153.6MHz Main clock
37		3C	60			
38		80	128		1920	Hor Active = 1920
39		1F	31		287	Hor Blanking = 287
3A		71	113		-	4 bits of Hor. Active + 4 bits of Hor. Blanking
3B		38	56		1080	Ver Active = 1080
3C		50	80		80	Ver Blanking = 80
3D		40	64		-	4 bits of Ver. Active + 4 bits of Ver. Blanking
3E		30	48		48	Hor Sync Offset = 48
3F		20	32		32	H Sync Pulse Width = 32
40		36	54		3	V sync Offset = 3 line
41		00	0		6	V Sync Pulse width : 6 line
42		58	88		344	Horizontal Image Size = 344 mm (Low 8 bits)
43		C1	193		193	Vertical Image Size = 193 mm (Low 8 bits)
44		10	16		-	4 bits of Hor Image Size + 4 bits of Ver Image Size
45		00	0		0	Hor Border (pixels)
46	00	0		0	Vertical Border (Lines)	
47	1A	26			Refer to right table	

SPEC. NUMBER

SPEC. TITLE

PAGE

NT156FHM-N41 Product Specification Rev. O

30 OF 32

48	Detailed timing/monitor descriptor #2	D6	214		94.3	94.3MHz Main clock
49		24	36			
4A		80	128		1920	Hor Active = 1920
4B		DE	222		222	Hor Blanking = 222
4C		70	112		-	4 bits of Hor. Active + 4 bits of Hor. Blanking
4D		38	56		1080	Ver Active = 768
4E		14	20		20	Ver Blanking = 20
4F		40	64		-	4 bits of Ver. Active + 4 bits of Ver. Blanking
50		64	100		100	Hor Sync Offset = 100
51		64	100		100	H Sync Pulse Width = 100
52		44	68		20	V sync Offset = 20 line
53		05	5		20	V Sync Pulse width : 20 line
54		58	88		344	Horizontal Image Size = 344 mm (Low 8 bits)
55		C1	193		193	Vertical Image Size = 193 mm (Low 8 bits)
56		10	16		-	4 bits of Hor Image Size + 4 bits of Ver Image Size
57		00	0		0	Hor Border (pixels)
58		00	0		0	Vertical Border (Lines)
59		1A	26			
5A		Detailed timing/monitor descriptor #3	00	0		Nvidia nvDPS Lowest refresh rate that does not cause any visual/optical side effect
5B	00		0			
5C	00		0			
5D	00		0			
5E	00		0			
5F	00		0			
60	00		0			
61	00		0			
62	00		0			
63	00		0			
64	00		0			
65	00		0			
66	00	0				
67	00	0				
68	00	0				
69	00	0				
6A	00	0				
6B	00	0				

6C	Detailed timing/monitor descriptor #4	00	0		0	Detailed Timing Description #4
6D		00	0		0	Flag
6E		00	0		0	Reserved
6F		02	2			For Brightness Table and Power consumption
70		00	0		0	Flag
71		0C	12			PWM % [7:0] @ Step 0
72		43	67			PWM % [7:0] @ Step 5
73		F6	246			PWM % [7:0] @ Step 10
74		0B	11			Nits [7:0] @ Step 0
75		3C	60			Nits [7:0] @ Step 5
76		6E	110			Nits [7:0] @ Step 10
77		0F	15			Panel Electronics Power @32x32 Chess Pattern=
78		10	16			Backlight Power @60 nits=
79		1C	28			Backlight Power @Step 10=
7A		73	115			Nits @ 100% PWM Duty =
7B		00	0		0	Flags
7C		00	0		0	Flags
7D		00	0		0	Flags
7E		Extension flag	00	0		
7F	Checksum	DD	221	221	-	