



**PROPRIETARY NOTE**  
THIS SPECIFICATION IS THE PROPERTY OF BOE BJ AND SHALL NOT BE REPRODUCED OR COPIED WITHOUT THE WRITTEN PERMISSION OF BOE BJ AND MUST BE RETURNED TO BOE BJ UPON ITS REQUEST

SPEC. NUMBER

PRODUCT GROUP

Rev.

ISSUE DATE

PAGE

TFT-LCD

P0

2014.05.14

1 OF 29

# NT156WHM-N10

## Preliminary Product Specification

Rev. P0

*For HYVISION Internal Use Only*

HEFEI XINSHENG OPTOELECTRONICS TECHNOLOGY CO.,LTD



PRODUCT GROUP

REV

ISSUE DATE

TFT- LCD PRODUCT

P0

2014.05.14

SPEC. NUMBER

SPEC. TITLE

NT156WHM-N10 Preliminary Product Specification

PAGE

2 OF 29

REVISION HISTORY

REV.	ECN No.	DESCRIPTION OF CHANGES	DATE	PREPARED
P0	-	Initial Release	2014.05.14	张言萍

For HYVISION Internal Use Only

## Contents

No.	Items	Page
	REVISION HISTORY	2
	CONTENTS	3
1.0	General Description	4
2.0	Absolute Maximum ratings	6
3.0	Electrical specifications.	7
4.0	Optical specifications.	10
5.0	Interface Connection	15
6.0	Signal Timing waveforms	19
7.0	Signal Timing waveforms of interface signal	21
8.0	Input signals, Basic display colors & gray scale of colors	23
9.0	Power sequence	24
10.0	Connector description	25
11.0	Mechanical Characteristics	26
12.0	Reliability Test	27
13.0	Handling & Cautions.	27
14.0	Label	28
15.0	Packing information	28
16.0	Mechanical Outline Dimension	31
17.0	EDID Table	33

## 1.0 GENERAL DESCRIPTION

### 1.1 Introduction

NT156WHM-N10 is a color active matrix TFT LCD module using amorphous silicon TFT's (Thin Film Transistors) as an active switching devices. This module has a 15.6 inch diagonally measured active area with HD resolutions (1366 horizontal by 768 vertical pixel array). Each pixel is divided into RED, GREEN, BLUE dots which are arranged in vertical Stripe and this module can display 262,144 colors. The TFT-LCD panel used for this module is a low reflection and higher color type. Therefore, this module is suitable for Notebook PC. The LED Driver for back-light driving is built in this model.

All input signals are LVDS interface compatible.

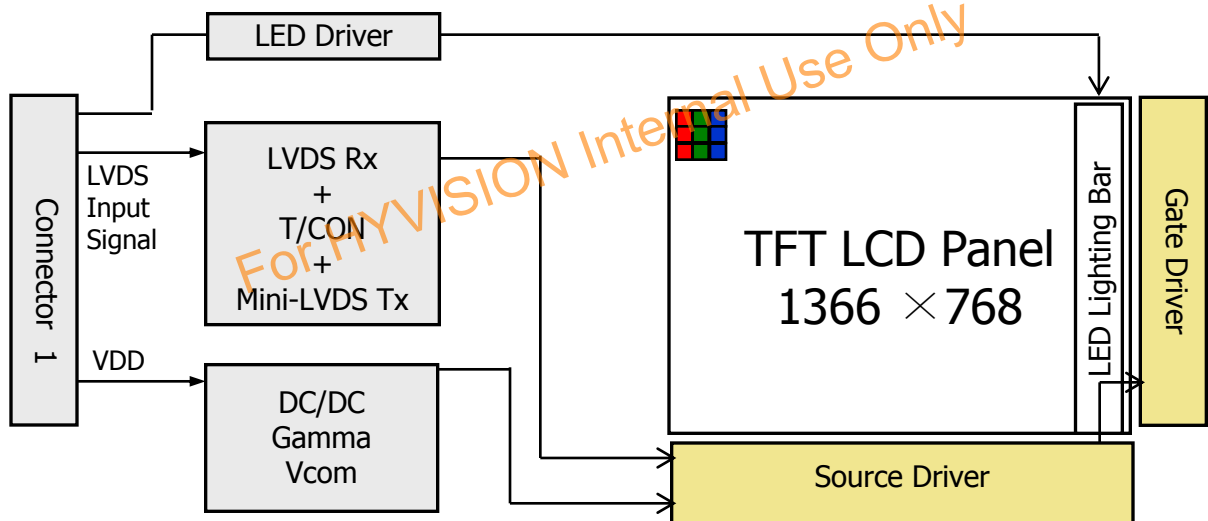

### 1.2 Features

- 1 Channel LVDS Interface with 1 pixel / clock
- Thin and light weight
- 6-bit color depth, display 262K colors
- Single LED Lighting Bar. (Down side/Horizontal Direction)
- Data enable signal mode
- Up/Down Mounting Frame
- Green Product (RoHS & Halogen free product)
- On board LED Driving circuit
- Low driving voltage and low power consumption
- On board EDID chip

### 1.3 Application

- Notebook PC (Wide type)

### 1.4 General Specification

The followings are general specifications at the model NT156WHM-N10. (listed in Table 1.)

<Table 1. General Specifications>

Parameter	Specification	Unit	Remarks
Active area	344.23(H) × 193.54(V)	mm	
Number of pixels	1366 (H) × 768 (V)	pixels	
Pixel pitch	0.252 (H) X 0.252 (V)	mm	
Pixel arrangement	RGB Vertical stripe		
Display colors	262K	colors	
Display mode	Normally White		
Dimensional outline	359.5(H)*223.8(V) (W/PCB)*3.8(Max) 359.5(H)*206.5(V)*3.8(Max)	mm	
Weight	400 (max)	g	
Surface treatment	Glare		
Back-light	Lower Down side, 1-LED Lighting Bar type		Note 1
Power consumption	P <sub>D</sub> : 1.2 (max)	W	
	P <sub>BL</sub> :2.6(max)	W	
	P <sub>total</sub> :3.8(max)	W	

Notes : 1. LED Lighting Bar (36\*LED Array)

## 2.0 ABSOLUTE MAXIMUM RATINGS

The followings are maximum values which, if exceed, may cause faulty operation or damage to the unit. The operational and non-operational maximum voltage and current values are listed in Table 2.

< Table 2. Absolute Maximum Ratings >

Ta=25+/-2°C

Parameter	Symbol	Min.	Max.	Unit	Remarks
Power Supply Voltage	V <sub>DD</sub>	-0.3	4.0	V	Note 1
Logic Supply Voltage	V <sub>IN</sub>	V <sub>SS</sub> -0.3	V <sub>DD</sub> +0.3	V	
Operating Temperature	T <sub>OP</sub>	0	+50	°C	Note 2
Storage Temperature	T <sub>ST</sub>	-20	+60	°C	

- Notes : 1. Permanent damage to the device may occur if maximum values are exceeded functional operation should be restricted to the condition described under normal operating conditions.
2. Temperature and relative humidity range are shown in the figure below.  
 95 % RH Max. ( 40 °C ≥ Ta)  
 Maximum wet - bulb temperature at 39 °C or less. (Ta > 40 °C) No condensation.

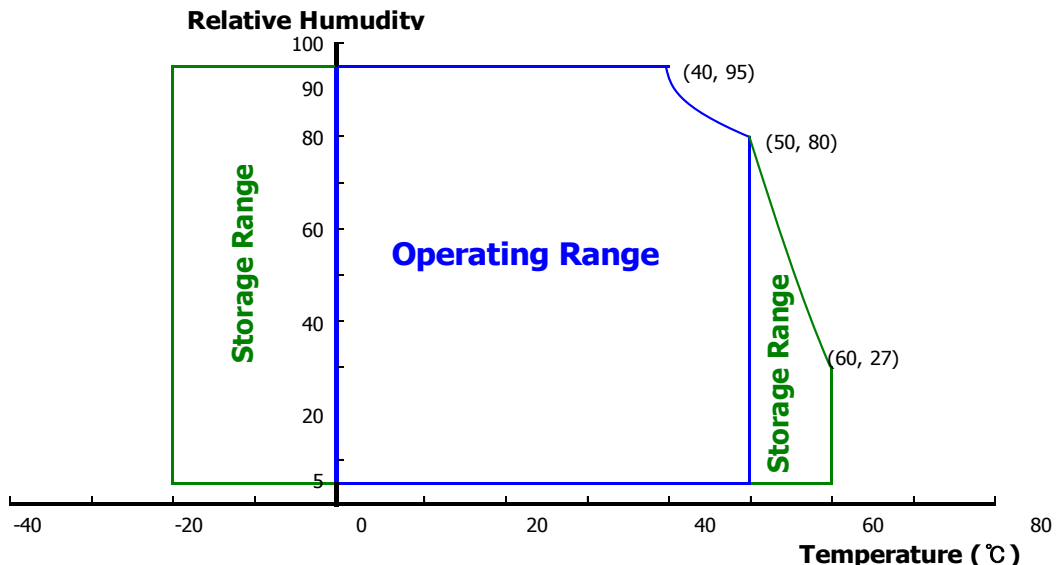

### 3.0 ELECTRICAL SPECIFICATIONS

#### 3.1 Electrical Specifications

< Table 3. Electrical specifications >

Ta=25+/-2°C

Parameter		Min.	Typ.	Max.	Unit	Remarks
Power Supply Voltage	V <sub>DD</sub>	3.0	3.3	3.6	V	Note 1
Permissible Input Ripple Voltage	V <sub>RF</sub>	-	-	100	mV	At V <sub>DD</sub> = 3.3V
Power Supply Current	I <sub>DD</sub>	-	TBD	-	mA	Note 1
Differential Input Voltage	V <sub>ID</sub>	200	-	600	mV	
Power Consumption	P <sub>D</sub>	-	1.0	1.2	W	Note 1
	P <sub>BL</sub>	-	-	2.6	W	Note 2
	P <sub>total</sub>	-	-	3.8	W	

Notes : 1. The supply voltage is measured and specified at the interface connector of LCM.  
The current draw and power consumption specified is for 3.3V at 25°C.

- a) Typ : Mosaic Pattern
- b) Max : Skip sub pixel255

2. Calculated value for reference (V<sub>LED</sub> × I<sub>LED</sub>)

### 3.2 Backlight Unit

< Table 4. LED Driving guideline specifications >

Ta=25+/-2°C

Parameter		Min.	Typ.	Max.	Unit	Remarks	
LED Forward Voltage		V <sub>F</sub>	-	-	3.1	V	-
LED Forward Current		I <sub>F</sub>	-	20	-	mA	-
LED Power Consumption		P <sub>LED</sub>	-	-	2.6	W	Note 1
LED Life-Time		N/A	15,000	-	-	Hour	I <sub>F</sub> = 20mA
Power supply voltage for LED Driver		V <sub>LED</sub>	5	12	21	V	
EN Control Level	Backlight on		2.5		5.0	V	
	Backlight off		0		1.0	V	
PWM Control Level	PWM High Level		2.5		5.0	V	
	PWM Low Level		0		0.1	V	
PWM Control Frequency		F <sub>PWM</sub>	100	-	10,000	Hz	
Duty Ratio		-	1	-	100	%	Note3

Notes : 1. Power supply voltage 12V for LED Driver

Calculator Value for reference  $I_F \times V_F \times 36 / \text{efficiency} = P_{LED}$

2. The LED Life-time define as the estimated time to 50% degradation of initial luminous.

3. 1% duty cycle is achievable with a dimming frequency less than 1KHz.



### 3.3 LED structure

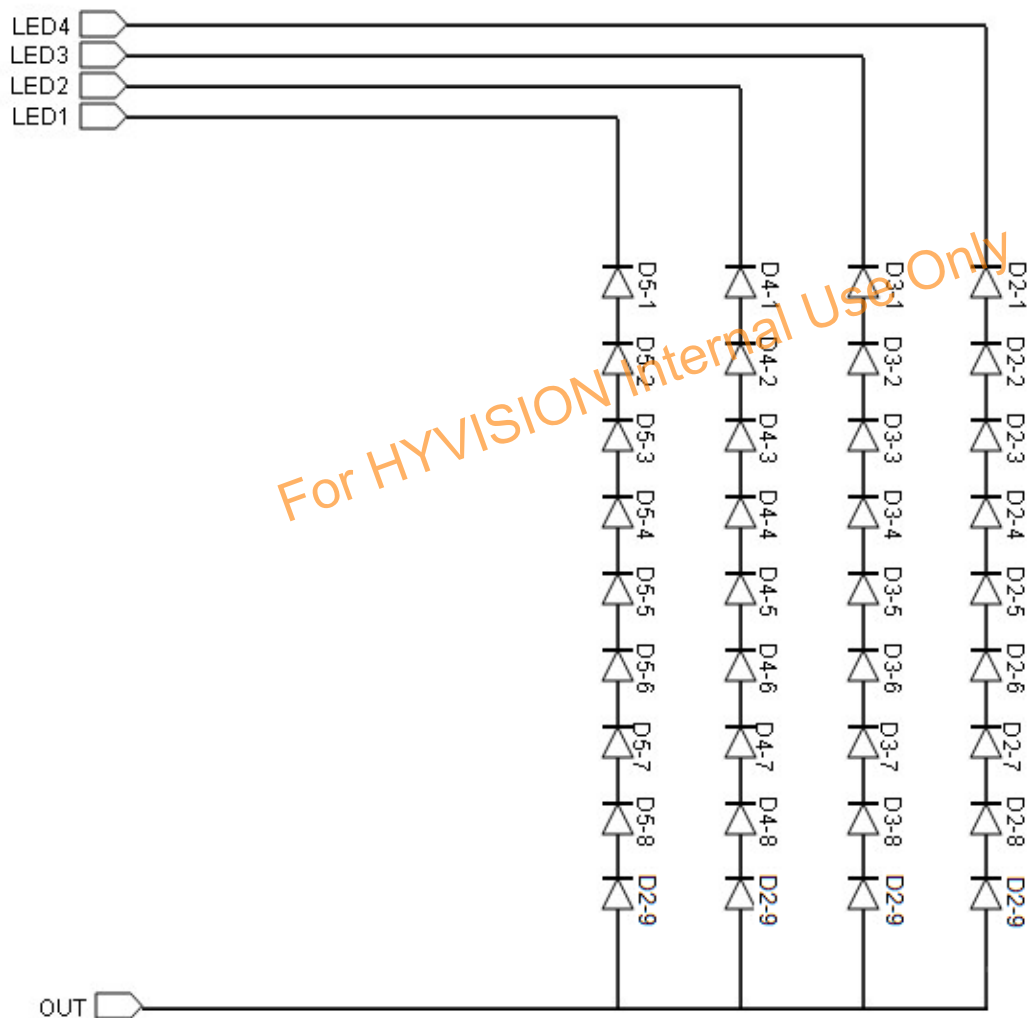

## 4.0 OPTICAL SPECIFICATION

### 4.1 Overview

The test of Optical specifications shall be measured in a dark room (ambient luminance  $\leq 1$  lux and temperature =  $25 \pm 2^\circ\text{C}$ ) with the equipment of Luminance meter system (Goniometer system and TOPCON BM-5) and test unit shall be located at an approximate distance 50cm from the LCD surface at a viewing angle of  $\theta$  and  $\Phi$  equal to  $0^\circ$ . We refer to  $\theta\Phi=0$  ( $=\theta_3$ ) as the 3 o'clock direction (the "right"),  $\theta\Phi=90$  ( $=\theta_{12}$ ) as the 12 o'clock direction ("upward"),  $\theta\Phi=180$  ( $=\theta_9$ ) as the 9 o'clock direction ("left") and  $\theta\Phi=270$  ( $=\theta_6$ ) as the 6 o'clock direction ("bottom"). While scanning  $\theta$  and/or  $\Phi$ , the center of the measuring spot on the Display surface shall stay fixed. The backlight should be operating for 30 minutes prior to measurement. VDD shall be  $3.3 \pm 0.3\text{V}$  at  $25^\circ\text{C}$ . Optimum viewing angle direction is 6 'clock.

### 4.2 Optical Specifications

<Table 5. Optical Specifications>

Parameter		Symbol	Condition	Min.	Typ.	Max.	Unit	Remark
Viewing Angle range	Horizontal	$\theta_3$	CR > 10	-	45	-	Deg.	Note 1
		$\theta_9$		-	45	-	Deg.	
	Vertical	$\theta_{12}$		-	20	-	Deg.	
		$\theta_6$		-	40	-	Deg.	
Luminance Contrast ratio		CR	$\Theta = 0^\circ$	-	500			Note 2
Luminance of White	5 Points	$Y_w$	$\Theta = 0^\circ$ ILED = 20mA	187	220	-	cd/m <sup>2</sup>	Note 3
White Luminance uniformity	5 Points	$\Delta Y_5$		80	-	-		Note 4
	13 Points	$\Delta Y_{13}$		65	-	-		
White Chromaticity		$x_w$	$\Theta = 0^\circ$	0.283	0.313	0.343		Note 5
		$y_w$		0.299	0.329	0.359		
Reproduction of color	Red	$x_R$	$\Theta = 0^\circ$	-0.03	0.590	+0.03		
		$y_R$			0.350			
	Green	$x_G$			0.330			
		$y_G$			0.555			
	Blue	$x_B$			0.153			
		$y_B$			0.119			
Gamut					45		%	
Response Time (Rising + Falling)		$T_{RT}$	Ta = $25^\circ\text{C}$ $\Theta = 0^\circ$	-	12	-	ms	Note 6
Cross Talk		CT	$\Theta = 0^\circ$	-	-	2.0	%	Note 7

**Notes :**

1. Viewing angle is the angle at which the contrast ratio is greater than 10. The viewing angles are determined for the horizontal or 3, 9 o'clock direction and the vertical or 6, 12 o'clock direction with respect to the optical axis which is normal to the LCD surface (see FIGURE 1).

2. Contrast measurements shall be made at viewing angle of  $\Theta = 0$  and at the center of the LCD surface. Luminance shall be measured with all pixels in the view field set first to white, then to the dark (black) state .

(see FIGURE 1) Luminance Contrast Ratio (CR) is defined mathematically.

$$CR = \frac{\text{Luminance when displaying a white raster}}{\text{Luminance when displaying a black raster}}$$

3. Center Luminance of white is defined as luminance values of 5 point average across the LCD surface. Luminance shall be measured with all pixels in the view field set first to white. This measurement shall be taken at the locations shown in FIGURE 2 for a total of the measurements per display.

4. The White luminance uniformity on LCD surface is then expressed as :  $\Delta Y = \text{Minimum Luminance of 5(or 13) points} / \text{Maximum Luminance of 5(or 13) points}$ .  
(see FIGURE 2 and FIGURE 3).

5. The color chromaticity coordinates specified in Table 5 shall be calculated from the spectral data measured with all pixels first in red, green, blue and white. Measurements shall be made at the center of the panel.

6. The electro-optical response time measurements shall be made as FIGURE 4 by switching the "data" input signal ON and OFF. The times needed for the luminance to change from 10% to 90% is  $T_r$ , and 90% to 10% is  $T_d$ .

7. Cross-Talk of one area of the LCD surface by another shall be measured by comparing the luminance ( $Y_A$ ) of a 25mm diameter area, with all display pixels set to a gray level, to the luminance ( $Y_B$ ) of that same area when any adjacent area is driven dark.  
(See FIGURE 5).

### 4.3 Optical measurements

**Figure 1. Measurement Set Up**

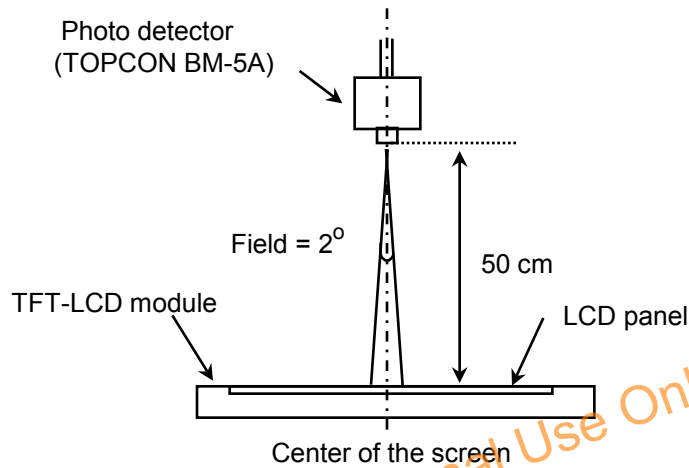

Optical characteristics measurement setup

**Figure 2. White Luminance and Uniformity Measurement Locations (5 points)**

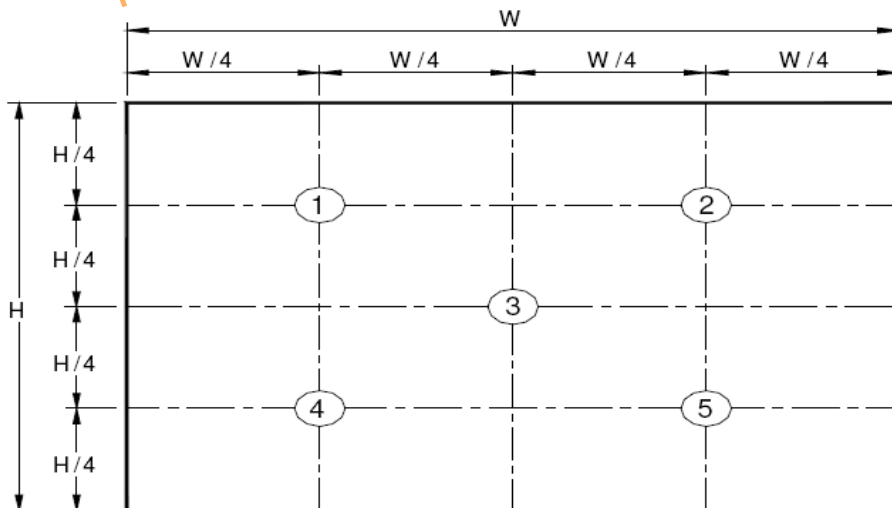

Center Luminance of white is defined as luminance values of center 5 points across the LCD surface. Luminance shall be measured with all pixels in the view field set first to white. This measurement shall be taken at the locations shown in FIGURE 2 for a total of the measurements per display.

**Figure 3. Uniformity Measurement Locations (13 points)**

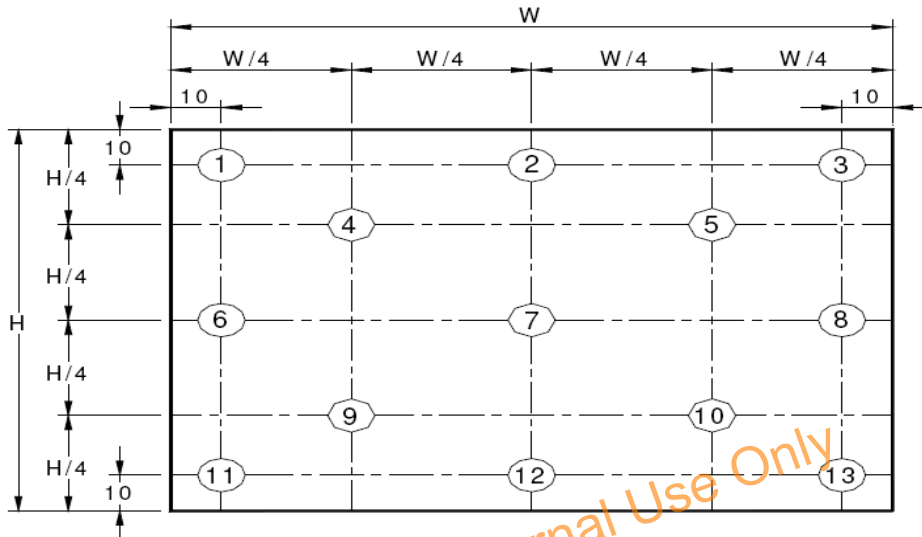

The White luminance uniformity on LCD surface is then expressed as :  $\Delta Y_5 = \text{Minimum Luminance of five points} / \text{Maximum Luminance of five points}$  (see FIGURE 2) ,  $\Delta Y_{13} = \text{Minimum Luminance of 13 points} / \text{Maximum Luminance of 13 points}$  (see FIGURE 3).

**Figure 4. Response Time Testing**

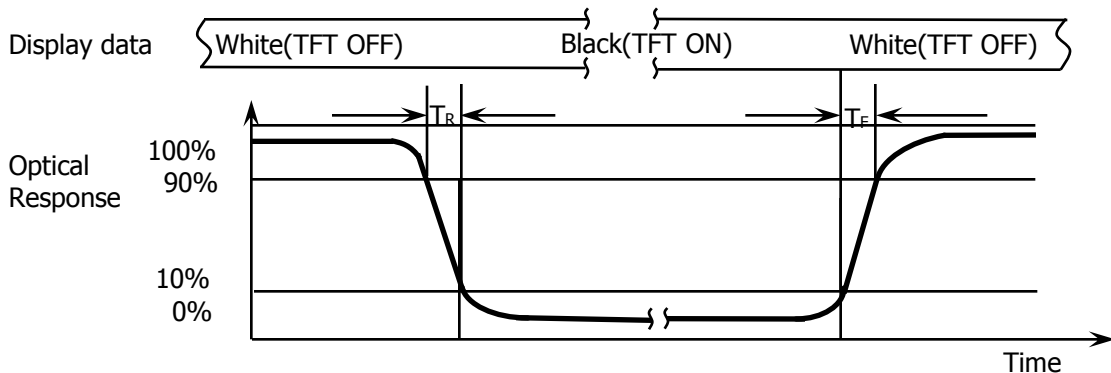

The electro-optical response time measurements shall be made as shown in FIGURE 4 by switching the “data” input signal ON and OFF. The times needed for the luminance to change from 10% to 90% is  $T_d$  and 90% to 10% is  $T_r$ .

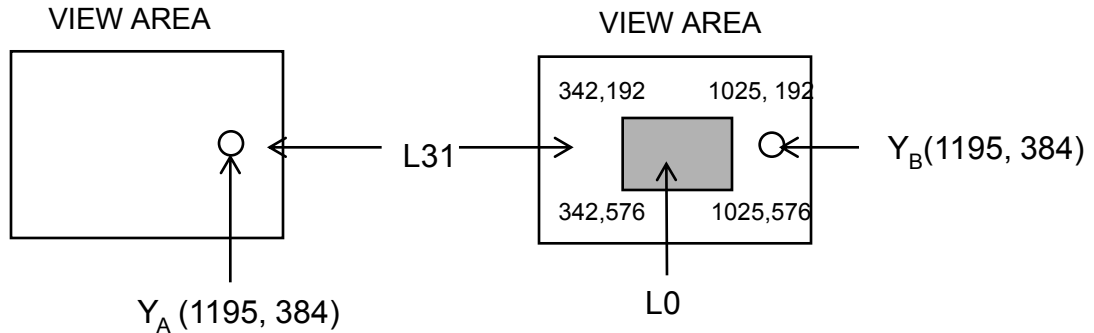
**Figure 5. Cross Modulation Test Description**

$$\text{Cross-Talk (\%)} = \left| \frac{Y_B - Y_A}{Y_A} \right| \times 100$$

Where:

$Y_A$  = Initial luminance of measured area ( $\text{cd/m}^2$ )

$Y_B$  = Subsequent luminance of measured area ( $\text{cd/m}^2$ )

The location measured will be exactly the same in both patterns

Cross-Talk of one area of the LCD surface by another shall be measured by comparing the luminance ( $Y_A$ ) of a 25mm diameter area, with all display pixels set to a gray level, to the luminance ( $Y_B$ ) of that same area when any adjacent area is driven dark (Refer to FIGURE 5).

## 5.0 INTERFACE CONNECTION.

### 5.1 Electrical Interface Connection

The electronics interface connector is UJU IS050-L30B-C10 or Compatible.

The connector interface pin assignments are listed in Table 6.

<Table 6. Pin Assignments for the Interface Connector>

<b>Terminal</b>	<b>Symbol</b>	<b>Functions</b>
Pin No.	Symbol	Description
1	NC	No Connection
2	VDDIN	Power Supply, 3.3V (typ.)
3	VDDIN	Power Supply, 3.3V (typ.)
4	VDC	VDC 3.3V power for EDID
5	NC	No Connection
6	CLK EDID	EDID Clock
7	Data EDID	EDID Data
8	RxIN0-	Transmission Data of 0 Negative -
9	RxIN0+	Transmission Data of 0 Positive +
10	GND	Ground
11	RxIN1-	Transmission Data of 1 Negative -
12	RxIN1+	Transmission Data of 1 Positive +
13	GND	Ground
14	RxIN2-	Transmission Data of 2 Negative -
15	RxIN2+	Transmission Data of 2 Positive +
16	GND	Ground
17	RxCLKIN-	Sampling Clock of Negative -
18	RxCLKIN+	Sampling Clock of Positive +
19	NC	No Connection
20	NC	No Connection
21	NC	No Connection
22	GND	Ground
23	NC	No Connection
24	NC	No Connection
25	GND	Ground
26	(CE)	No Connection
27	(CTL)	No Connection
28	GND	Ground
29	NC	No Connection
30	NC	No Connection

<b>Terminal</b>	<b>Symbol</b>	<b>Functions</b>
Pin No.	Symbol	Description
31	VLED_GND	LED Ground
32	VLED_GND	LED Ground
33	VLED_GND	LED Ground
34	NC	No Connection
35	PWM	System PWM Signal Input
36	LED_EN	LED enable pin(+3.3V Input)
37	CABC	CABC enable pin (0:Bypass;1 Enable)
38	VLED	LED Power Supply 6V-21V
39	VLED	LED Power Supply 6V-21V
40	VLED	LED Power Supply 6V-21V

For HYVISION Internal Use Only



## 5.2 LVDS Interface

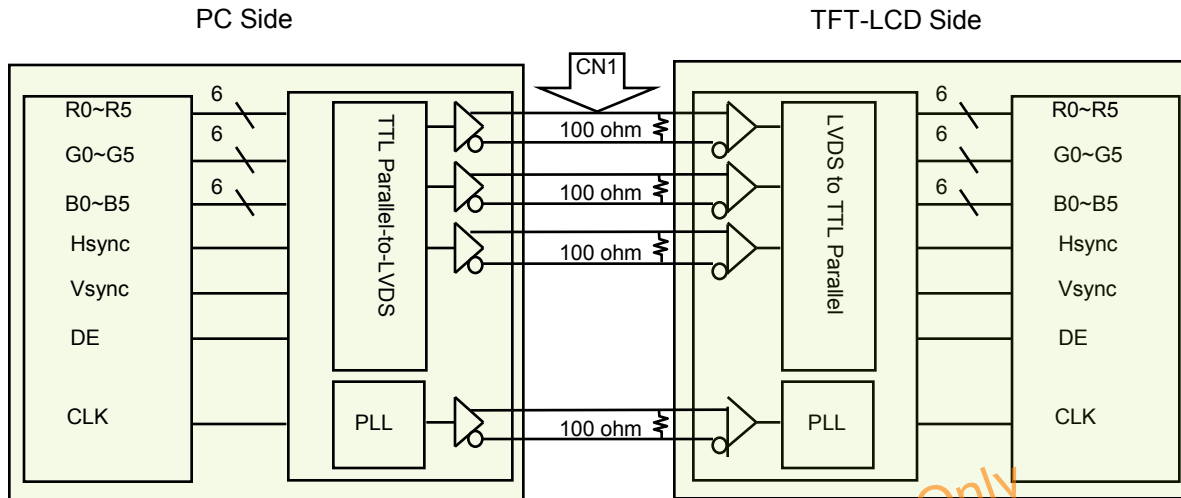

Note. Transmitter : Thine THC63LVDM63A or equivalent.  
Transmitter is not contained in Module.

### 5.3.1 LVDS Input signal

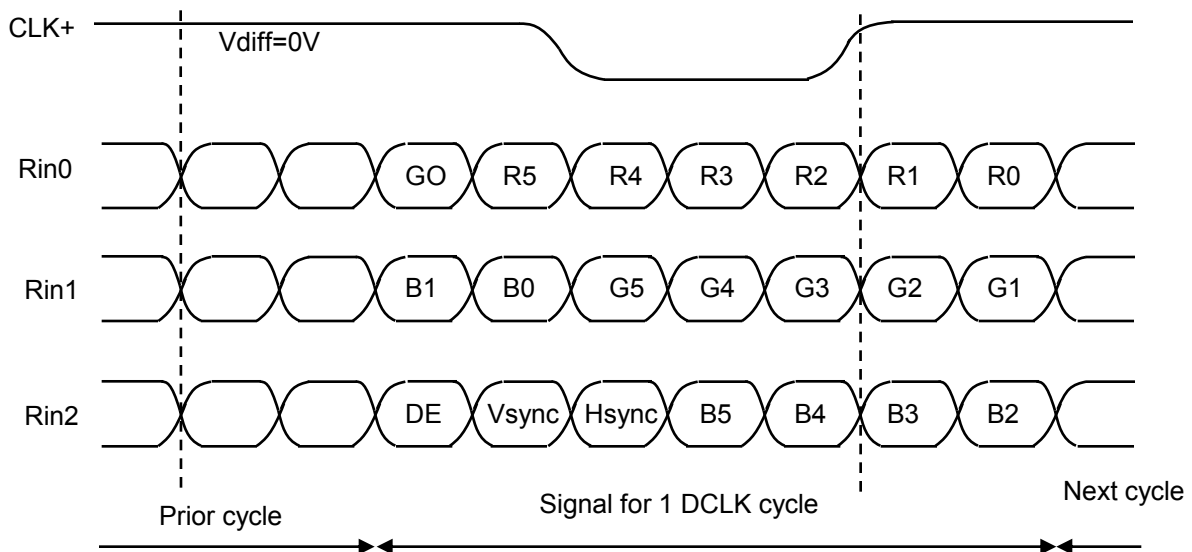

Note. Pin connection in case of using Thine THC63LVDM63A

### 5.3.2 Data Input Format

<Table 6. Pin Assignments for the BLU & LCM Connector>

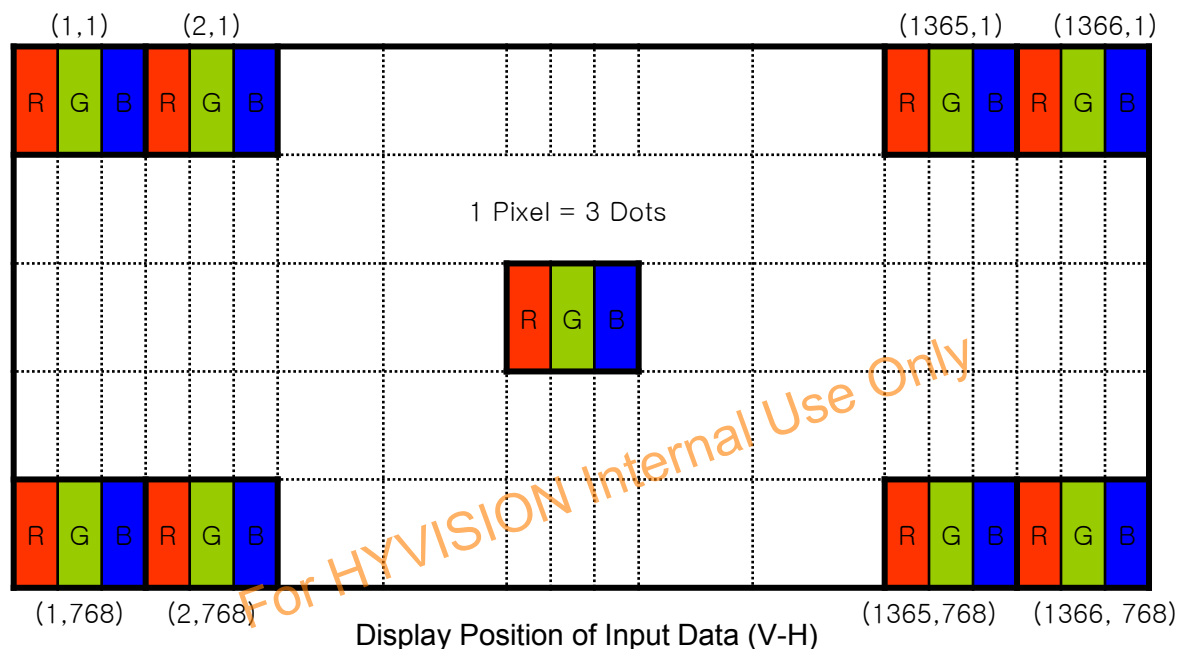

### 5.4 Back-light & LCM Interface Connection

Interface Connector: CRT 098-10W10AO or Equivalent

<Table 7. Pin Assignments for the BLU & LCM Connector>

Pin No.	Symbol	Description	Pin No.	Symbol	Description
1	LED1	LED cathode connection	6	NC	No Connection
2	LED2	LED cathode connection	7	NC	No Connection
3	LED3	LED cathode connection	8	Vout	LED anode connection
4	LED4	LED cathode connection	9	Vout	LED anode connection
5	NC	No Connection	10	Vout	LED anode connection

## 6.0 SIGNAL TIMING SPECIFICATION

### 6.1 The NT156WHM-N10 is operated by the DE only.

Item		Symbols	Min	Typ	Max	Unit
Clock	Frequency	1/Tc	67.5	72.3	76.3	MHz
	High Time	Tch	-	4/7	-	Tc
	Low Time	Tcl	-	3/7	-	Tc
Frame Period		Tv	778	790	802	lines
			-	60	-	Hz
			-	16.7	-	ms
Vertical Display Period		Tvd	768	768	768	lines
One line Scanning Period		Th	1446	1526	1586	clocks
Horizontal Display Period		Thd	1366	1366	1366	clocks

Note\*: This Module can support low frame refresh rate 50Hz & 40Hz.

## 6.2 LVDS Rx Interface Timing Parameter

The specification of the LVDS Rx interface timing parameter is shown in Table 8.

<Table 8. LVDS Rx Interface Timing Specification>

Item	Symbol	Min	Typ	Max	Unit	Remark
CLKIN Period	tRCIP	-	13.83	25	nsec	
CLK Difference	tCdiff	-tRCIP*(3/7)	0	+tRCIP*(3/7)	nsec	
Input Data 0	tRIP1	-0.4	0.0	+0.4	nsec	
Input Data 1	tRIP0	tRCIP/7-0.4	tRCIP/7	tRCIP/7+0.4	nsec	
Input Data 2	tRIP6	2 × tRCIP/7-0.4	2 × tRCIP/7	2 × tRCIP/7+0.4	nsec	
Input Data 3	tRIP5	3 × tRCIP/7-0.4	3 × tRCIP/7	3 × tRCIP/7+0.4	nsec	
Input Data 4	tRIP4	4 × tRCIP/7-0.4	4 × tRCIP/7	4 × tRCIP/7+0.4	nsec	
Input Data 5	tRIP3	5 × tRCIP/7-0.4	5 × tRCIP/7	5 × tRCIP/7+0.4	nsec	
Input Data 6	tRIP2	6 × tRCIP/7-0.4	6 × tRCIP/7	6 × tRCIP/7+0.4	nsec	

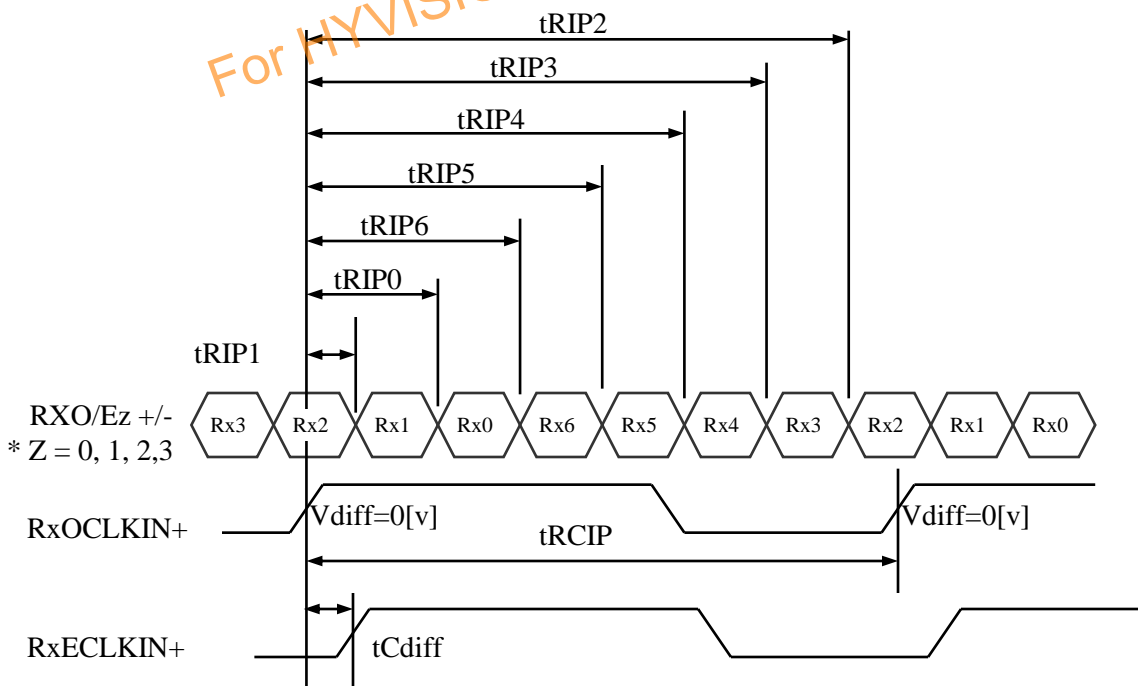

\* Vdiff = (RXO/Ez+)-(RXO/Ez-),..., (RXO/ECLK+)-(RXO/ECLK-)

## 7.0 SIGNAL TIMING WAVEFORMS OF INTERFACE SIGNAL

### 7.1 Sync Timing Waveforms

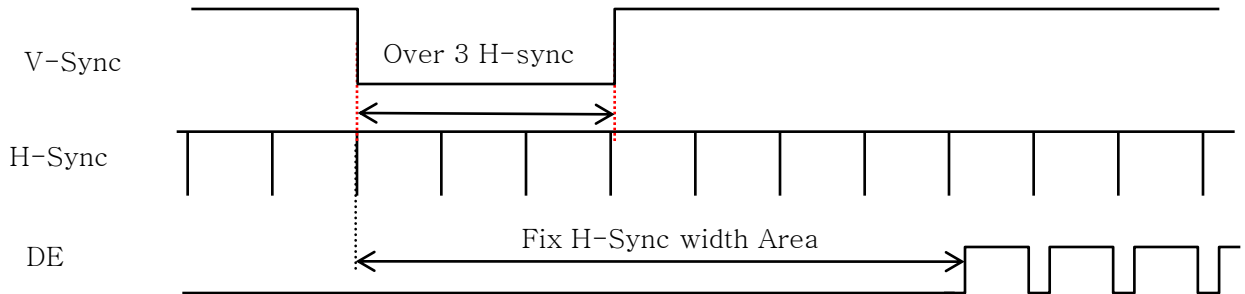

- 1) Need over 3 H-sync during V-Sync Low
- 2) Fix H-Sync width from V-Sync falling edge to first rising edge

### 7.2 Vertical Timing Waveforms

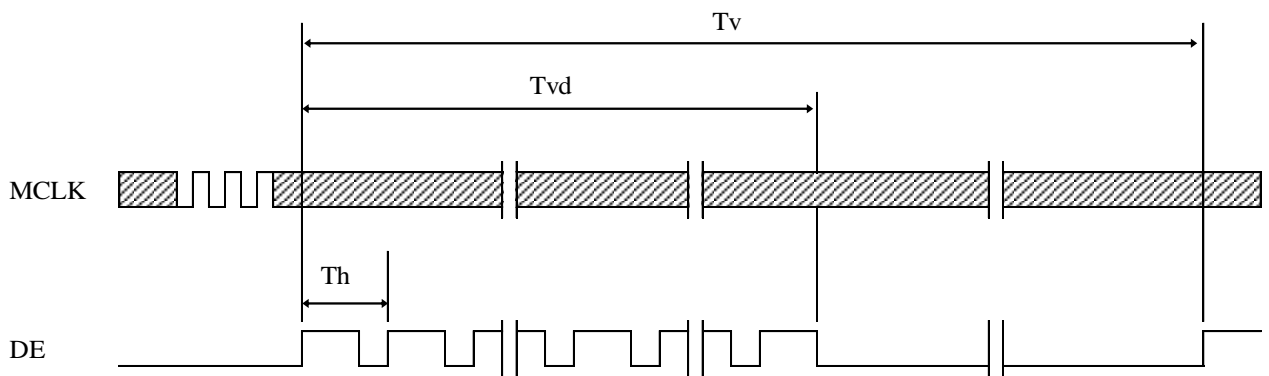

### 7.3 Horizontal Timing Waveforms

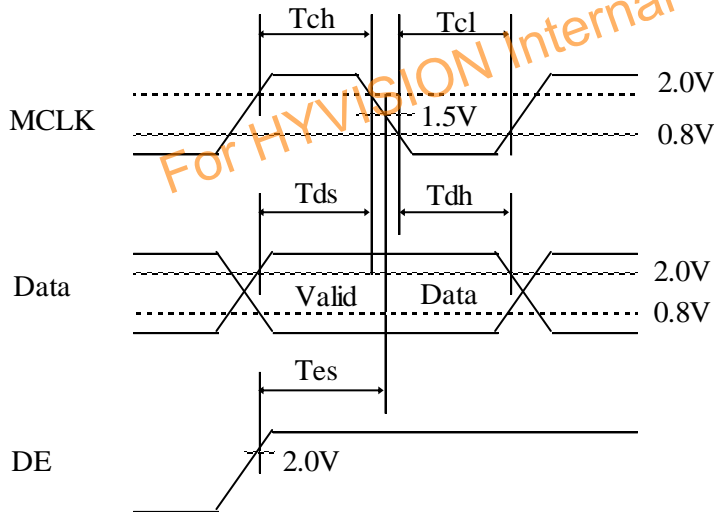
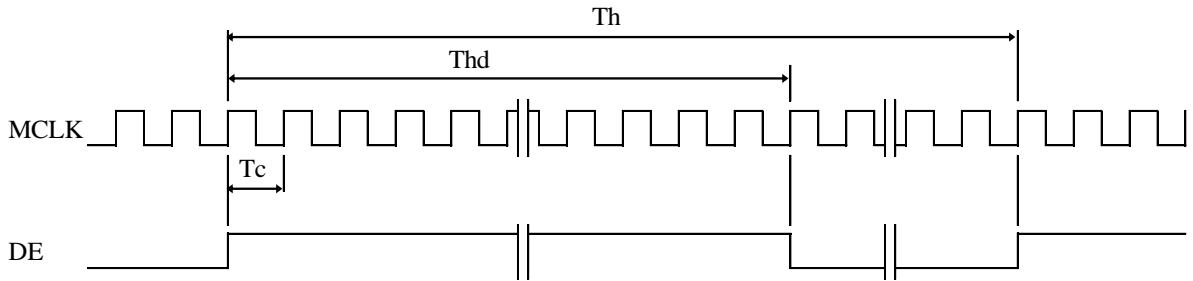

## 8.0 INPUT SIGNALS, BASIC DISPLAY COLORS & GRAY SCALE OF COLORS

	Colors & Gray scale	Data signal																	
		R0	R1	R2	R3	R4	R5	G0	G1	G2	G3	G4	G5	B0	B1	B2	B3	B4	B5
Basic colors	Black	0	0	0	0	0	0	0	0	0	0	0	0	0	0	0	0	0	0
	Blue	0	0	0	0	0	0	0	0	0	0	0	0	1	1	1	1	1	1
	Green	0	0	0	0	0	0	1	1	1	1	1	1	0	0	0	0	0	0
	Light Blue	0	0	0	0	0	0	1	1	1	1	1	1	1	1	1	1	1	1
	Red	1	1	1	1	1	1	0	0	0	0	0	0	0	0	0	0	0	0
	Purple	1	1	1	1	1	1	0	0	0	0	0	0	1	1	1	1	1	1
	Yellow	1	1	1	1	1	1	1	1	1	1	1	1	0	0	0	0	0	0
White	1	1	1	1	1	1	1	1	1	1	1	1	1	1	1	1	1	1	
Gray scale of Red	Black	0	0	0	0	0	0	0	0	0	0	0	0	0	0	0	0	0	0
	△	1	0	0	0	0	0	0	0	0	0	0	0	0	0	0	0	0	0
	Darker	0	1	0	0	0	0	0	0	0	0	0	0	0	0	0	0	0	0
	△	↑						↑						↑					
	▽	↓						↓						↓					
	Brighter	1	0	1	1	1	1	0	0	0	0	0	0	0	0	0	0	0	0
▽	0	1	1	1	1	1	0	0	0	0	0	0	0	0	0	0	0	0	
Red	1	1	1	1	1	1	0	0	0	0	0	0	0	0	0	0	0	0	
Gray scale of Green	Black	0	0	0	0	0	0	0	0	0	0	0	0	0	0	0	0	0	0
	△	0	0	0	0	0	0	1	0	0	0	0	0	0	0	0	0	0	0
	Darker	0	0	0	0	0	0	0	1	0	0	0	0	0	0	0	0	0	0
	△	↑						↑						↑					
	▽	↓						↓						↓					
	Brighter	0	0	0	0	0	0	1	0	1	1	1	1	0	0	0	0	0	0
▽	0	0	0	0	0	0	0	1	1	1	1	1	0	0	0	0	0	0	
Green	0	0	0	0	0	0	1	1	1	1	1	1	0	0	0	0	0	0	
Gray scale of Blue	Black	0	0	0	0	0	0	0	0	0	0	0	0	0	0	0	0	0	0
	△	0	0	0	0	0	0	0	0	0	0	0	0	1	0	0	0	0	0
	Darker	0	0	0	0	0	0	0	0	0	0	0	0	0	1	0	0	0	0
	△	↑						↓						↑					
	▽	↓						↓						↓					
	Brighter	0	0	0	0	0	0	0	0	0	0	0	0	1	0	1	1	1	1
▽	0	0	0	0	0	0	0	0	0	0	0	0	0	1	1	1	1	1	
Blue	0	0	0	0	0	0	0	0	0	0	0	0	1	1	1	1	1	1	
Gray scale of White & Black	Black	0	0	0	0	0	0	0	0	0	0	0	0	0	0	0	0	0	0
	△	1	0	0	0	0	0	1	0	0	0	0	0	1	0	0	0	0	0
	Darker	0	1	0	0	0	0	0	1	0	0	0	0	0	1	0	0	0	0
	△	↑						↑						↑					
	▽	↓						↓						↓					
	Brighter	1	0	1	1	1	1	1	0	1	1	1	1	1	0	1	1	1	1
▽	0	1	1	1	1	1	0	1	1	1	1	1	0	1	1	1	1	1	
White	1	1	1	1	1	1	1	1	1	1	1	1	1	1	1	1	1	1	

## 9.0 POWER SEQUENCE

To prevent a latch-up or DC operation of the LCD module, the power on/off sequence shall be as shown in below

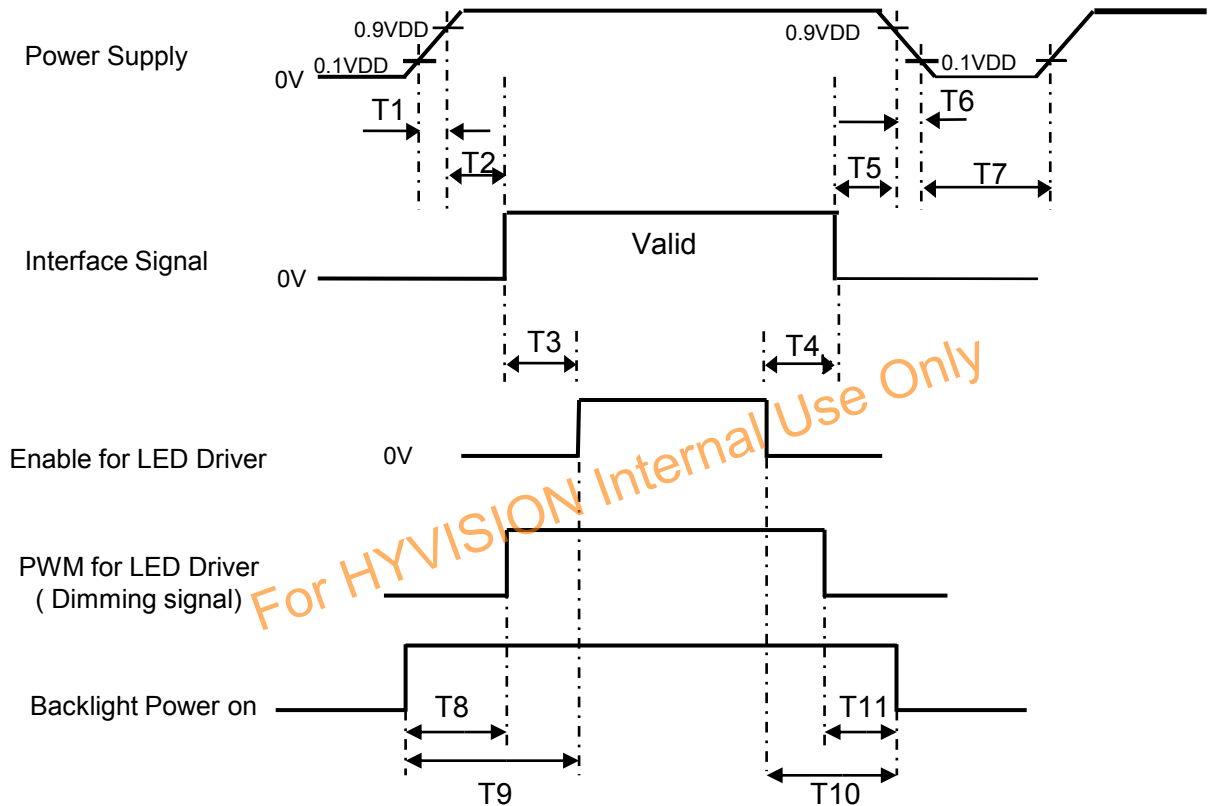

- $0.5\text{ms} \leq T1 \leq 10\text{ms}$
- $0\text{ms} \leq T2 \leq 50\text{ms}$
- $200\text{ms} \leq T3$
- $0\text{ms} \leq T4$
- $0\text{ms} \leq T5$

- $0\text{ms} \leq T6 \leq 10\text{ms}$
- $150\text{ms} \leq T7$
- $0\text{ms} \leq T8$
- $0\text{ms} \leq T9$
- $0\text{ms} \leq T10$
- $0\text{ms} \leq T11$

### Notes:

1. When the power supply VDD is 0V, keep the level of input signals on the low or keep high impedance.
2. Do not keep the interface signal high impedance when power is on. Back Light must be turn on after power for logic and interface signal are valid.





### 10.0 Connector Description

Physical interface is described as for the connector on LCM.

These connectors are capable of accommodating the following signals and will be following components.

#### 10.1 TFT LCD Module

Connector Name /Description	For Signal Connector
Manufacturer	STM or Compatible
Type/ Part Number	MSAK24025P40G or Compatible
Mating housing/ Part Number	I-PEX 20455-040T-11 or Compatible

For HYVISION Internal Use Only

## 11.0 MECHANICAL CHARACTERISTICS

### 11.1 Dimensional Requirements

FIGURE 6 shows mechanical outlines for the model NT156WHM-N10. Other parameters are shown in Table 9.

<Table 9. Dimensional Parameters>

Parameter	Specification	Unit
Active Area	344.23 (H) × 193.54(V)	
Number of pixels	1366 (H) X 768 (V) (1 pixel = R + G + B dots)	
Pixel pitch	0.252 (H) X 0.252 (V)	
Pixel arrangement	RGB Vertical stripe	
Display colors	262k	
Display mode	Normally white	
Dimensional outline	359.5(H)*223.8(V) (W/PCB)*3.8(Max) 359.5(H)*206.5(V)*3.8(Max)	mm
Weight	400(Max)	gram
Back Light	Connector :CRT F10401-1092	
	LED, Horizontal-LED Array type	

### 11.2 Mounting

See FIGURE 6.

### 11.3 Glare and Polarizer Hardness.

The surface of the LCD has an glare coating to maximize readability and hard coating to reduce scratching.

### 11.4 Light Leakage

There shall not be visible light from the back-lighting system around the edges of the screen as seen from a distance 50cm from the screen with an overhead light level of 350lux.

## 12.0 RELIABILITY TEST

The Reliability test items and its conditions are shown in below.

<Table 10. Reliability test>

No	Test Items	Conditions
1	High temperature storage test	Ta = 60 °C, 240 hrs
2	Low temperature storage test	Ta = -20 °C, 240 hrs
3	High temperature & high humidity operation test	Ta = 50 °C, 80%RH, 240 hrs
4	High temperature operation test	Ta = 50 °C, 240 hrs
5	Low temperature operation test	Ta = 0 °C, 240 hrs
6	Thermal shock	Ta = -20 °C ↔ 60 °C (0.5 hr), 100 cycle
7	Vibration test (non-operating)	1.5G, 10~500Hz, Half Sine X,Y,Z / Sweep rate : 1 hour
8	Shock test (non-operating)	220G, Half Sine Wave 2msec ±X, ±Y, ±Z Once for each direction
9	Electro-static discharge test (non-operating)	Air : 150 pF, 330Ω, 15 KV Contact : 150 pF, 330Ω, 8 KV

## 13.0 HANDLING & CAUTIONS

### (1) Cautions when taking out the module

- Pick the pouch only, when taking out module from a shipping package.

### (2) Cautions for handling the module

- As the electrostatic discharges may break the LCD module, handle the LCD module with care. Peel a protection sheet off from the LCD panel surface as slowly as possible.
- As the LCD panel and back - light element are made from fragile glass material, impulse and pressure to the LCD module should be avoided.
- As the surface of the polarizer is very soft and easily scratched, use a soft dry cloth without chemicals for cleaning.
- Do not pull the interface connector in or out while the LCD module is operating.
- Put the module display side down on a flat horizontal plane.
- Handle connectors and cables with care.

### (3) Cautions for the operation

- When the module is operating, do not lose CLK, ENAB signals. If any one of these signals is lost, the LCD panel would be damaged.
- Obey the supply voltage sequence. If wrong sequence is applied, the module would be damaged.

**(4) Cautions for the atmosphere**

- Dew drop atmosphere should be avoided.
- Do not store and/or operate the LCD module in a high temperature and/or humidity atmosphere. Storage in an electro-conductive polymer packing pouch and under relatively low temperature atmosphere is recommended.

**(5) Cautions for the module characteristics**

- Do not apply fixed pattern data signal to the LCD module at product aging.
- Applying fixed pattern for a long time may cause image sticking.

**(6) Other cautions**

- Do not disassemble and/or re-assemble LCD module.
- Do not re-adjust variable resistor or switch etc.
- When returning the module for repair or etc., Please pack the module not to be broken. We recommend to use the original shipping packages.

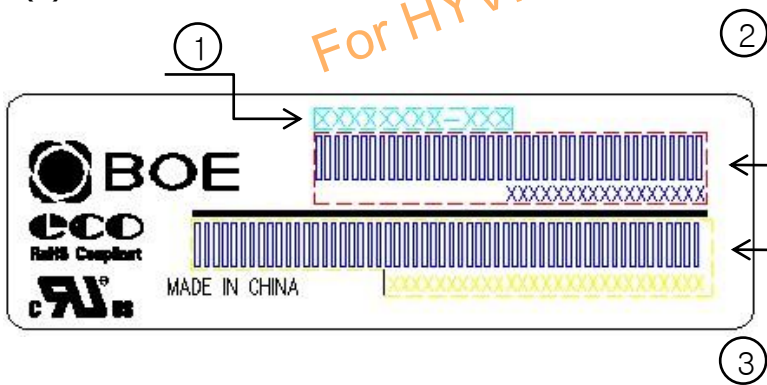
**14.0 LABEL**
**(1) Product label**

序号号标注部分需打印, 说明如下:

1. **FG-CODE**(前12位)
2. **MDL ID** 及其条形码
3. **PPID** 及其条形码

**Total Size:80×25mm**

Digit Code	1	2	3	4	5	6	7	8	9	10	11	12	13	14	15	16	17
Code	S	L	S	5	1	2	3	5	9	4	2	0	0	0	1	D	B
Description	Model Code /GBN		Grade	Line	Year		Month	Model Extension Code (Last 4 Digits Of FGCOD)				Serial No 00001-ZZZZZZ					

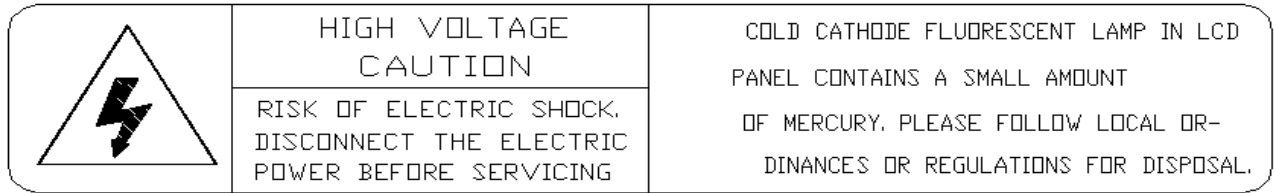
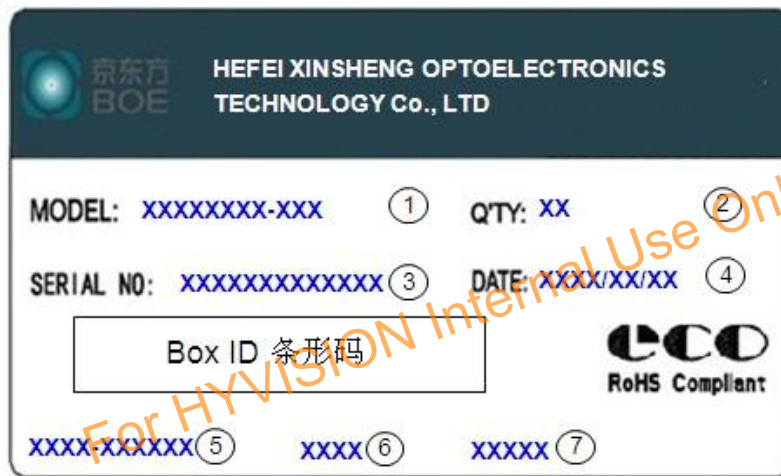
**(2) High voltage caution label**

**(3) Box label**

序列号标注部分需打印, 说明如下:

- 1. FG-CODE(前12位)**
- 2. 产品数量**
- 3. Box ID**
- 4. 包装日期**
- 5. 客户端段物料号(客户端)---暂不打印,预留空间**
- 6. FG-Code后四位**
- 7. 供应商代码 ---暂不打印**

**Total Size:110×55mm**

Digit	1	2	3	4	5	6	7	8	9	10	11	12	13
Code	S	L	S	5	1	2	3	D	0	0	0	6	8
Description	Products GBN		Grade	Line	Year		Month	Revision Code	SerialNo				

## 15.0 PACKING INFORMATION

### 15.1 Packing order

- Put Pad into the inner box

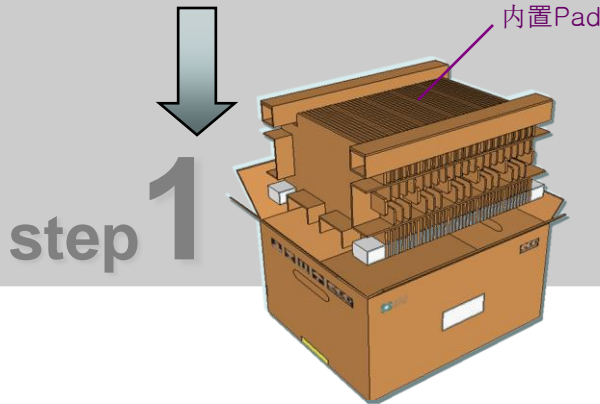

- Put module into the paper spacer and modules bundled by PE Bag

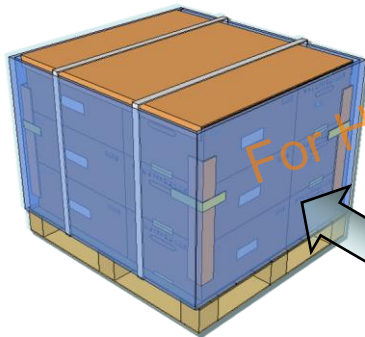
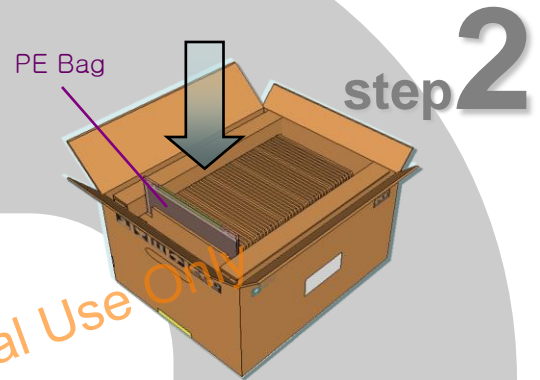

For HYVISION Internal Use Only

- Put Cover on the top of the pad

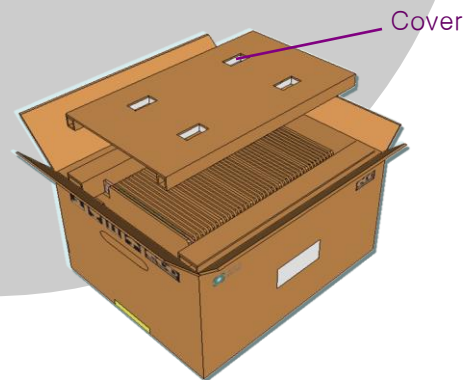

- 12ea Box/Pallet, 456ea MDL/Pallet

### 15.2 Notes

- Box Dimension:
- Package Quantity in one Box: pcs
- Total Weight: kg

## 16.0 MECHANICAL OUTLINE DIMENSION

Figure 6. TFT-LCD Module Outline Dimension (Front View)

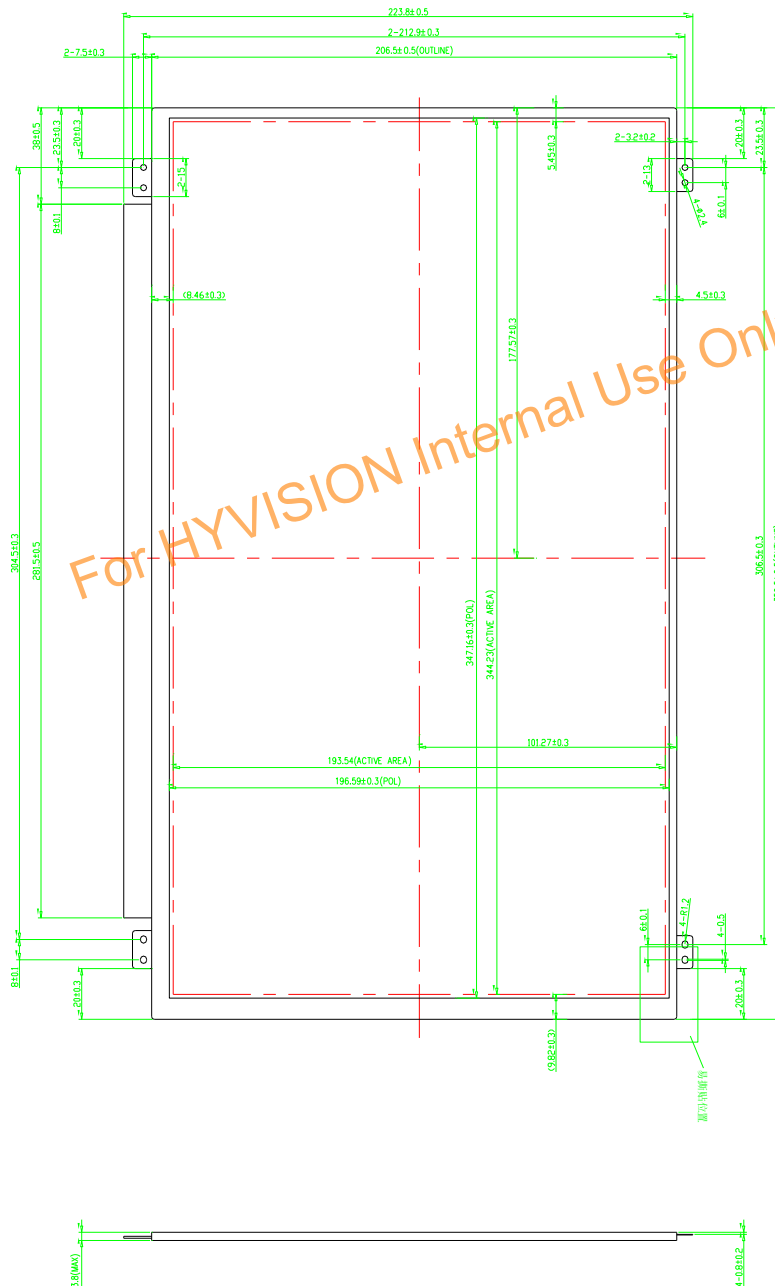
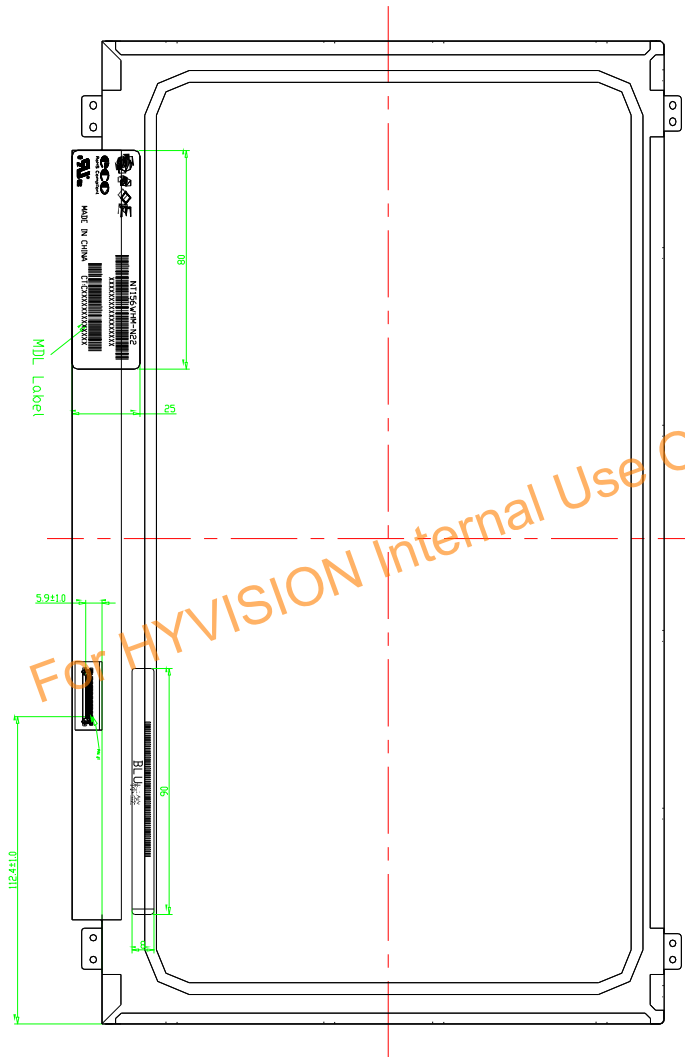

Figure 7. TFT-LCD Module Outline Dimensions (Rear view)







PRODUCT GROUP

REV

ISSUE DATE

TFT- LCD PRODUCT

P0

2014.05.14

SPEC. NUMBER

SPEC. TITLE

NT156WHM-N10 Preliminary Product Specification

PAGE

33 OF 29

**17.0 EDID Table**

**TBD**

For HYVISION Internal Use Only