



Data Sheet

NT7532

65 x 132 RAM-Map

LCD Controller/Driver

V2.0

REVISION HISTORY.....	2
FEATURES.....	3
GENERAL DESCRIPTION	3
PAD CONFIGURATION.....	4
BLOCK DIAGRAM.....	5
PAD DESCRIPTIONS	6
FUNCTIONAL DESCRIPTIONS	11
ABSOLUTE MAXIMUM RATING*	47
DC ELECTRICAL CHARACTERISTICS.....	48
AC CHARACTERISTICS	50
BONDING DIAGRAM.....	56
PACKAGE INFORMATION	62
ORDERING INFORMATION.....	63

Revision History

Version	Content	Date
1.0	Released	Apr. 2004
2.0	Modify the typing error of Duty setting (page 10, pads description of Duty0 and Duty1)	May 2004

Features

- Direct RAM data display using the display RAM. When RAM data bit is 0, it is not displayed. When RAM data bit is 1, it is displayed. (At normal display)
- RAM capacity: 65 x 132 = 8580 bits
- Many command functions: Read/Write Display Data, Display ON/OFF, Normal/Reverse Display, Page Address Set, Set Display Start Line, Set LCD Bias, Electronic contrast Controls, V0 voltage regulation internal resistor ratio set, Read Modify Write, Select Segment Driver Direction, Power Save (sleep/standby).
- High-speed 8-bit microprocessor interface allowing direct connection to both the 8080 and 6800 series interface
- 4-wire Serial Peripheral Interface (SPI)
- Maximum 12V LCD driving output voltage
- 2X / 3X / 4X on chip DC-DC converter
- Voltage regulator
- Voltage follower
- On-chip oscillator

General Description

The NT7532 is a single-chip LCD driver for dot-matrix liquid crystal displays, which is directly connectable to a microcomputer bus. It accepts 8-bit parallel or serial display data directly sent from a microcomputer and stores it on an on-chip display RAM. It generates an LCD drive signal independent from the microprocessor clock.

The set of the on-chip display RAM of 65 x 132 bits and a one-to-one correspondence between LCD panel pixel dots and on-chip RAM bits permits implementation of displays with a high degree of freedom.

The NT7532 contain 65 common output circuits and 132 segment output circuits, so that a single NT7532 chip can make 65 x 132, 55 x 132, 49 x 132 and 33 x 132 dot displays with pad option (DUTY1, DUTY0).

No external operation clock is required for RAM read/write operations. Accordingly, this driver can be operated with a minimum current consumption and its on-board low-current-consumption liquid crystal power supply can implement a high-performance handy display system with minimum current consumption and the smallest LSI configuration.

Pad Configuration

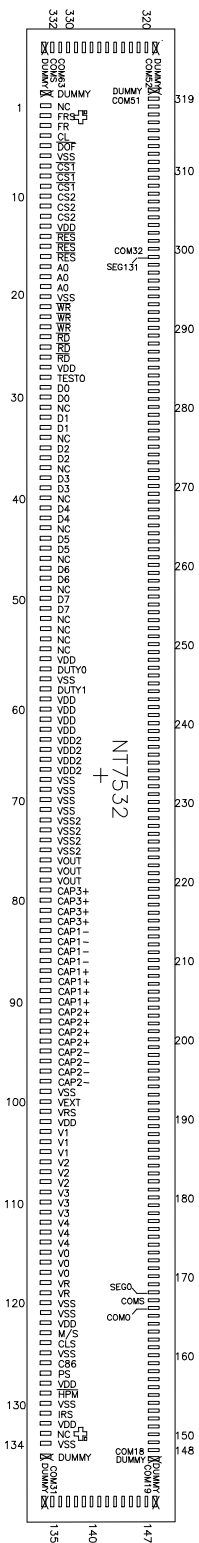

Block Diagram

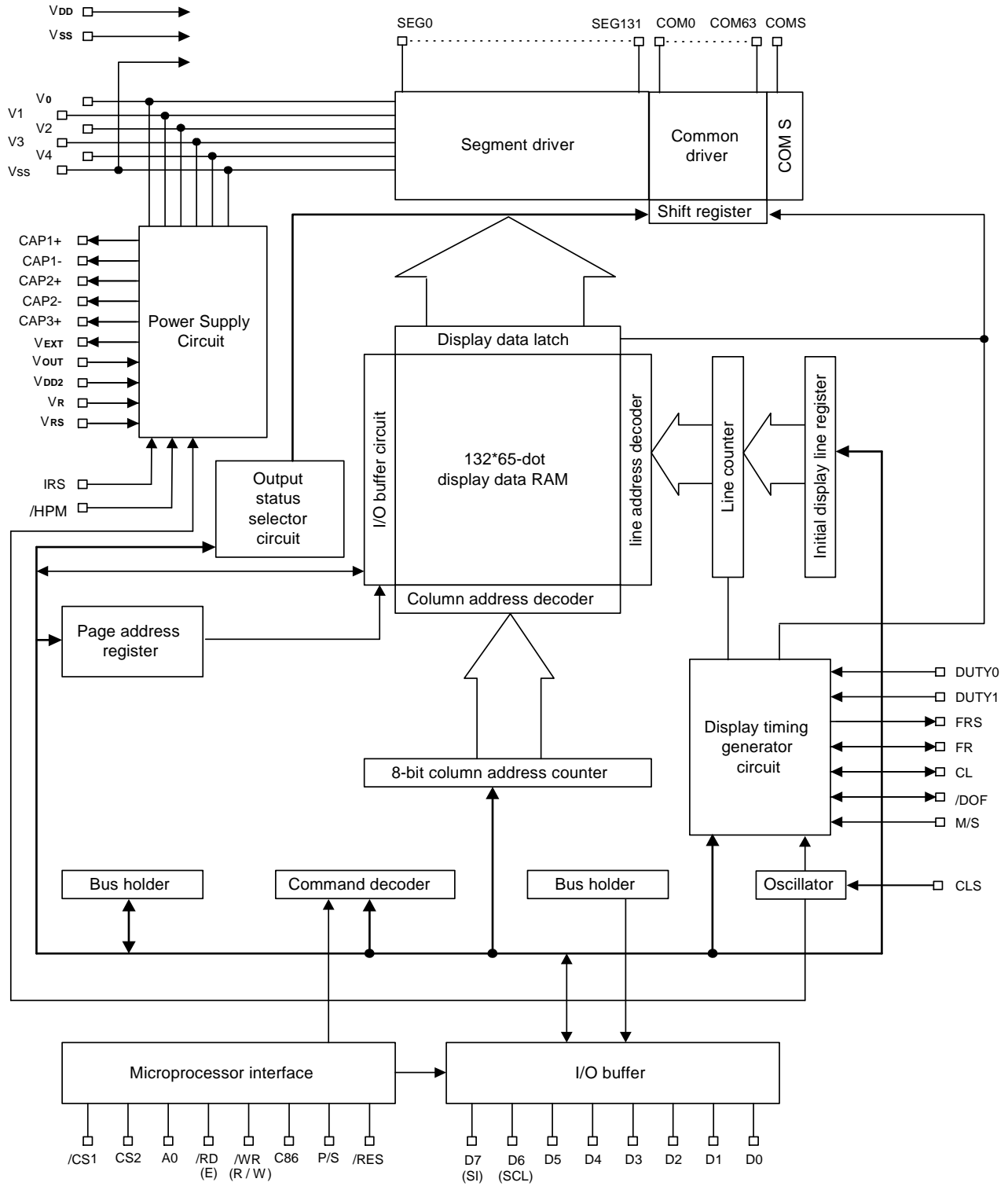

Pad Descriptions
Power Supply

Pad No.	Symbol	I/O	Descriptions																														
60 – 63	V _{DD}	Supply	2.4 - 3.5V power supply input. These pads must be connected to each other																														
13,27,56, 102,122, 128,132	V _{DD}	Supply	2.4 - 3.5V power supply output for pad option																														
64 – 67	V _{DD2}	Supply	This is the reference power supply for the step-up voltage circuit of the LCD. These pads must be connected to each other																														
68 – 71	V _{SS}	Supply	Ground. These pads must be connected to each other																														
72 – 75	V _{SS2}	Supply	Ground. These pads must be connected to each other																														
6,20,58, 99, 120, 121,125, 130,134	V _{SS}	Supply	Ground output for pad option																														
115 – 117 103 – 105 106 – 108 109 – 111 112 – 114	V ₀ V ₁ V ₂ V ₃ V ₄	Supply	<p>LCD driver supplies voltages. The voltage determined by LCD cell is impedance-converted by a resistive driver or an operation amplifier for application. Voltages should be according to the following relationship: $V_0 \geq V_1 \geq V_2 \geq V_3 \geq V_4 \geq V_{SS}$ When the on-chip operating power circuit is on, the following voltages are supplied to V₁ to V₄ by the on-chip power circuit. Voltage selection is performed by the Set LCD Bias command.</p> <table border="1"> <thead> <tr> <th>LCD bias</th> <th>V₁</th> <th>V₂</th> <th>V₃</th> <th>V₄</th> </tr> </thead> <tbody> <tr> <td>1/5 bias</td> <td>4/5V₀</td> <td>3/5V₀</td> <td>2/5V₀</td> <td>1/5V₀</td> </tr> <tr> <td>1/6 bias</td> <td>5/6V₀</td> <td>4/6V₀</td> <td>2/6V₀</td> <td>1/6V₀</td> </tr> <tr> <td>1/7 bias</td> <td>6/7V₀</td> <td>5/7V₀</td> <td>2/7V₀</td> <td>1/7V₀</td> </tr> <tr> <td>1/8 bias</td> <td>7/8V₀</td> <td>6/8V₀</td> <td>2/8V₀</td> <td>1/8V₀</td> </tr> <tr> <td>1/9 bias</td> <td>8/9V₀</td> <td>7/9V₀</td> <td>2/9V₀</td> <td>1/9V₀</td> </tr> </tbody> </table>	LCD bias	V ₁	V ₂	V ₃	V ₄	1/5 bias	4/5V ₀	3/5V ₀	2/5V ₀	1/5V ₀	1/6 bias	5/6V ₀	4/6V ₀	2/6V ₀	1/6V ₀	1/7 bias	6/7V ₀	5/7V ₀	2/7V ₀	1/7V ₀	1/8 bias	7/8V ₀	6/8V ₀	2/8V ₀	1/8V ₀	1/9 bias	8/9V ₀	7/9V ₀	2/9V ₀	1/9V ₀
LCD bias	V ₁	V ₂	V ₃	V ₄																													
1/5 bias	4/5V ₀	3/5V ₀	2/5V ₀	1/5V ₀																													
1/6 bias	5/6V ₀	4/6V ₀	2/6V ₀	1/6V ₀																													
1/7 bias	6/7V ₀	5/7V ₀	2/7V ₀	1/7V ₀																													
1/8 bias	7/8V ₀	6/8V ₀	2/8V ₀	1/8V ₀																													
1/9 bias	8/9V ₀	7/9V ₀	2/9V ₀	1/9V ₀																													

LCD Driver Supplies

Pad No.	Symbol	I/O	Descriptions
83 – 86	CAP1-	O	Capacitor 1- pad for internal DC/DC voltage converter
87 – 90	CAP1+	O	Capacitor 1+ pad for internal DC/DC voltage converter
95 – 98	CAP2-	O	Capacitor 2- pad for internal DC/DC voltage converter
91 – 94	CAP2+	O	Capacitor 2+ pad for internal DC/DC voltage converter
79 – 82	CAP3+	O	Capacitor 3+ pad for internal DC/DC voltage converter
76 – 78	V _{OUT}	O	DC/DC voltage converter output
118 – 119	VR	I	Voltage adjustment pad. Applies voltage between V _O and V _{SS} using a resistive divider
100	VEXT	I	This is the external input reference voltage (VREF) for the internal voltage regulator. It is valid only when external VREF is used. VEXT must be $\geq 2.4V$ and $\leq V_{DD2}$ When using internal VREF, this pad must be NC
101	VRS	I	Select the internal voltage regulator or external voltage regulator, VRS = 0: using the external VREF VRS = 1: using the internal VREF

System Bus Connection Pads

Pad No.	Symbol	I/O	Descriptions
29 – 30 32 – 33 35 – 36 38 – 39 41 – 42 44 – 45 47 – 48 50 – 51	D0 D1 D2 D3 D4 D5 D6 (SCL) D7 (SI)	I/O	This is an 8-bit bi-directional data bus that connects to an 8-bit or 16-bit standard MPU data bus. When the serial interface is selected (P/S = “L”), then D7 serves as the serial data input terminal (SI) and D6 serves as the serial clock input terminal (SCL). At this time, D0 to D5 are set to high impedance. When the chip select is inactive, D0 to D7 are set to high impedance.
17 – 19	A0	I	This is connected to the least significant bit of the normal MPU address bus, and it determines whether the data bits are data or a command A0 = “H”: Indicates that D0 to D7 are display data A0 = “L”: Indicates that D0 to D7 are control data
14 – 16	/RES	I	When /RES is set to “L”, the settings are initialized The reset operation is performed by the /RES signal level
7 – 9 10 – 12	/CS1 CS2	I	This is the chip select signal. When /CS1 = “L” and CS2 = “H”, then the chip select becomes active, and data/command I/O is enabled
24 – 26	/RD (E)	I	When connected to an 8080 MPU, it is active LOW This pad is connected to the /RD signal of the 8080MPU, and the NT7532 data bus is in an output status when this signal is “L”. When connected to a 6800 Series MPU, this is active HIGH, this is used as an enable clock input of the 6800 series MPU.
21 – 23	/WR (R/W)	I	When connected to an 8080 MPU, this is active LOW. This terminal connects to the 8080 MPU /WR signal. The signals on the data bus are latched at the rising edge of the /WR signal. When connected to a 6800 Series MPU: This is the read/write control signal input terminal. When R/W = “H”: Read When R/W = “L”: Write
126	C86	I	This is the MPU interface switch terminal C86 = “H”: 6800 Series MPU interface C86 = “L”: 8080 MPU interface
129	/HPM	I	This is the power control terminal for the power supply circuit for liquid crystal drive. /HPM = “H”, Normal mode /HPM = “L”, High power mode This pad is enabled only when the master operation mode is selected and It is fixed to either “H” or “L” when the slave operation mode is selected.

System Bus Connection Pads (Continued)

127	P/S	I	<p>This is the parallel data input/serial data input switch terminal P/S = "H": Parallel data input P/S = "L": Serial data input The following applies depending on the P/S status:</p> <table border="1"> <thead> <tr> <th>P/S</th> <th>Data/Command</th> <th>Data</th> <th>Read/Write</th> <th>Serial clock</th> </tr> </thead> <tbody> <tr> <td>"H"</td> <td>A0</td> <td>D0 to D7</td> <td>/RD, /WR</td> <td>-</td> </tr> <tr> <td>"L"</td> <td>A0</td> <td>SI(D7)</td> <td>Write Only</td> <td>SCL(D6)</td> </tr> </tbody> </table> <p>When P/S = "L", D0 to D5 are HZ. D0 to D5 may be "H", "L" or Open. /RD(E) and /WR(R/W) are fixed to either "H" or "L". With serial data input, RAM display data reading is not supported.</p>	P/S	Data/Command	Data	Read/Write	Serial clock	"H"	A0	D0 to D7	/RD, /WR	-	"L"	A0	SI(D7)	Write Only	SCL(D6)
P/S	Data/Command	Data	Read/Write	Serial clock														
"H"	A0	D0 to D7	/RD, /WR	-														
"L"	A0	SI(D7)	Write Only	SCL(D6)														
124	CLS	I	<p>The terminal will select whether to enable or disable the display clock internal oscillator circuit CLS = "H": Internal oscillator circuit is enabled CLS = "L": Internal oscillator circuit is disabled (requires external input) When CLS = "L", input the display clock through the CL pad</p>															
123	M/S	I	<p>This terminal selects the master/slave operation for the NT7532 chips. Master operation outputs the timing signals that are required for the LCD display, while slave operation inputs the timing signals required for the liquid crystal display, synchronizing the liquid crystal display system.</p>															
4	CL	I/O	<p>This is the display clock input terminal When the NT7532 chip is used in master/slave mode, the various CL terminals must be connected.</p>															
3	FR	I/O	<p>This is the liquid crystal alternating current signal I/O terminal M/S = "H": Output M/S = "L": Input When the NT7532 chip is used in master/slave mode, the various FR terminal must be connected</p>															
5	/DOF	I/O	<p>This is the liquid crystal display blanking control terminal M/S = "H": Output M/S = "L": Input When the NT7532 chip is used in master/slave mode, the various /DOF terminals must be connected</p>															
2	FRS	O	<p>This is the output terminal for the static drive. This terminal is only enabled when the static indicator display is ON in master operation mode, and is used in conjunction with the FR terminal.</p>															
131	IRS	I	<p>This terminal selects the resistors for the V0 voltage level adjustment. IRS = "H", Use the internal resistors IRS = "L", Do not use the internal resistors The V0 voltage level is regulated by an external resistive voltage divider that is attached to the VR terminal This pad is enabled only when the master operation mode is selected. It is fixed to either "H" or "L" when the slave operation mode is selected.</p>															

Liquid Crystal Drive Pads

Pad No.	Symbol	I/O	Description
168 – 299	SEG0-131	O	Segment signal output for LCD display.
135 – 166 300 – 331	COM31-0 COM32-63	O	Common signal output for LCD display When in master/slave mode, the same signal is output by both master and slave.
167, 332	COMS	O	These are the COM output terminals for the indicator. Both terminals output the same signal. Do not connect these terminals if they are not used. When in master/slave mode, the same signal is output by both master and slave.

Configuration Pads

Pad No.	Symbol	I/O	Description															
57, 59	DUTY0, DUTY1	I	Select the LCD driving duty as below:															
			<table border="1"> <thead> <tr> <th>DUTY1</th> <th>DUTY0</th> <th>LCD driving duty</th> </tr> </thead> <tbody> <tr> <td>0</td> <td>0</td> <td>1/33</td> </tr> <tr> <td>0</td> <td>1</td> <td>1/49</td> </tr> <tr> <td>1</td> <td>0</td> <td>1/55</td> </tr> <tr> <td>1</td> <td>1</td> <td>1/65</td> </tr> </tbody> </table>	DUTY1	DUTY0	LCD driving duty	0	0	1/33	0	1	1/49	1	0	1/55	1	1	1/65
			DUTY1	DUTY0	LCD driving duty													
			0	0	1/33													
			0	1	1/49													
1	0	1/55																
1	1	1/65																

Test Pads

Pad No.	Symbol	I/O	Description
28	TEST0	I	Test pads, and they must be connected to V_{DD}
1,31,34, 37, 40,43,46, 49, 52 – 55, 133	NC		NC pads, no connection for user

Functional Descriptions

Microprocessor Interface

Interface type selection

The NT7532 can transfer data via 8-bit bi-directional data bus (D7 to D0) or via serial data input (SI). When high or low is selected for the parity of P/S pad either 8-bit parallel data input or serial data input can be selected as shown in Table 1. When serial data input is selected, the RAM data cannot be read out.

Table. 1

P/S	Type	/CS1	CS2	A0	/RD	/WR	C86	D7	D6	D0 to D5
H	Parallel Input	/CS1	CS2	A0	/RD	/WR	C86	D7	D6	D0 to D5
L	Serial Input	/CS1	CS2	A0	-	-	-	SI	SCL	(HZ)

“-” Must always be high or low

Parallel Input

When the NT7532 selects parallel input (P/S = high), the 8080 series microprocessor or 6800 series microprocessor can be selected by causing the C86 pad to go high or low as shown in Table 2.

Table. 2

C86	Type	/CS1	CS2	A0	/RD	/WR	D0 to D7
H	6800 microprocessor bus	/CS1	CS2	A0	E	R/W	D0 to D7
L	8080 microprocessor bus	/CS1	CS2	A0	/RD	/WR	D0 to D7

Data Bus Signals

The NT7532 identifies the data bus signal according to A0, E, R/W(/RD, /WR) signals.

Table. 3

Common	6800 processor (R/W)	8080 processor		Function
		/RD	/WR	
A0	(R/W)	/RD	/WR	
1	1	0	1	Reads display data
1	0	1	0	Writes display data
0	1	0	1	Reads status
0	0	1	0	Writes control data in the internal register. (Command)

Serial Interface (P/S is low)

When the serial interface has been selected (P/S = “L”), then when the chip is in an active state (/CS1= “L” and CS2 = “H”), the serial data input (SI) and the serial clock input (SCL) can be received. The serial data is read from the serial data input pin in the rising edge of the serial clocks D7, D6 through D0, in this order. This data is converted to 8 bits of parallel data in the rising edge of the eighth serial clock for processing.

The A0 input is used to determine whether or not the serial data input is displaying data, and when A0 = “L” then the data is command data. The A0 input is read and used for detection every 8th rising edge of the serial clock after the chip becomes active.

Figure 1 is the serial interface signal chart.

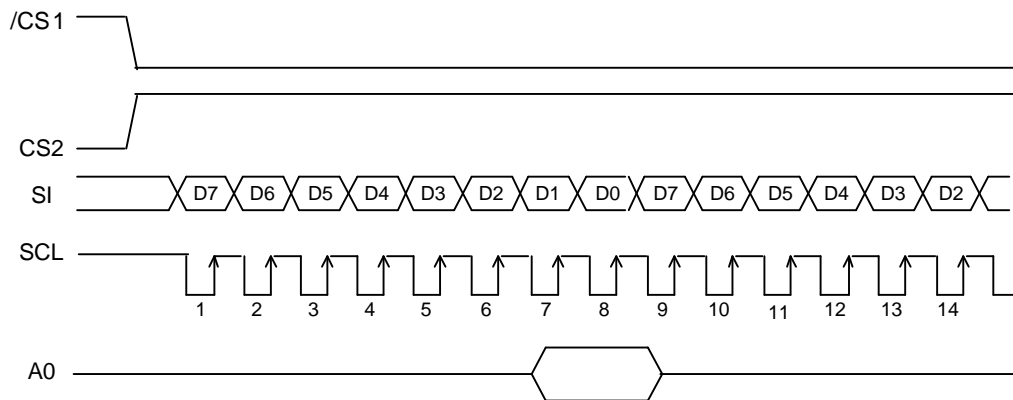

Figure. 1

- When the chip is not active, the shift registers and the counter are reset to their initial states.
- Reading is not possible while in serial interface mode.
- Caution is required on the SCL signal as to line-end reflections and external noise. We recommend the operation be rechecked on the actual equipment.

Chip Select Inputs

The NT7532 has two chip select pads. /CS1 and CS2 can interface to a microprocessor when /CS1 is low and CS2 is high. When these pads are set to any other combination. D0 to D7 are high impedance and A0, E (/RD) and R/W (/WR) inputs are disabled.

When serial input interface is selected. the shift register and counter are reset.

Access to Display Data RAM and Internal Registers

The NT7532 can perform a series of pipeline processing between LSI's using the bus holder of the internal data bus in order to match the operating frequency of display RAM and internal registers with the microprocessor. For example, the microprocessor reads data from display RAM in the first read (dummy) cycle, stores it in the bus holder, and outputs it onto the system bus in the next data read cycle.

Also, the microprocessor temporarily stores display data in the bus holder, and stores it in display RAM until the next data write cycle starts. When viewed from the microprocessor, the NT7532 access speed greatly depends on the cycle time rather than access time to the display RAM (t_{acc}). This view shows the data transfer speed to / from the microprocessor can increase. If the cycle time is inappropriate, the microprocessor can insert the NOP instruction that is equivalent to the wait cycle setup. However, there is a restriction in the display RAM read sequence. When an address is set, the specified address data is NOT output immediately following the read instruction. The address data is output during the second data read. A single dummy read must be inserted after the address setup and after the write cycle (refer to Figure2).

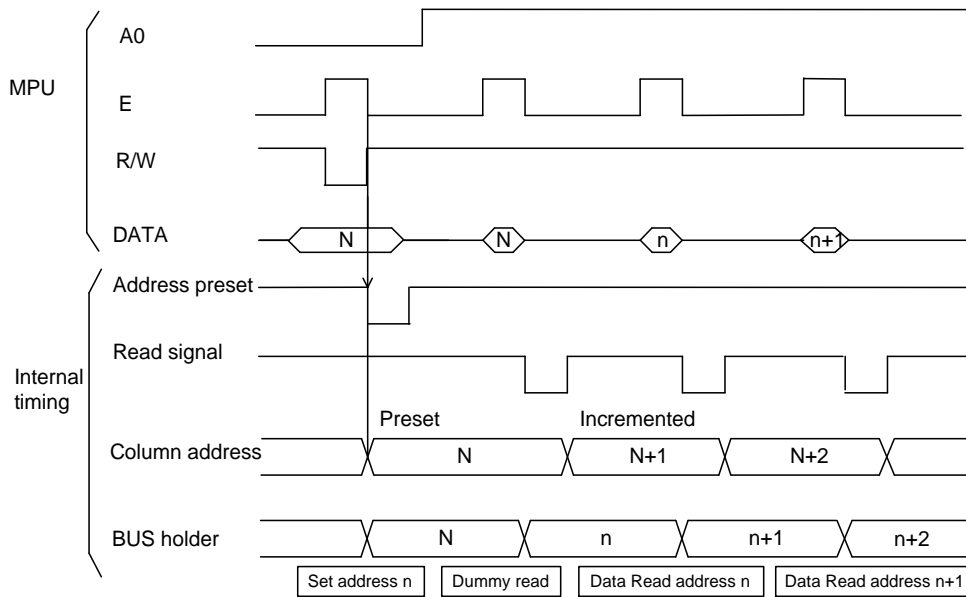
Figure. 2

Busy Flag

When the busy flag is “1” it indicates that the NT7532 chip is running internal processes, and at this time no command aside from a status read will be received. The busy flag is outputted to D7 pad with the read instruction. If the cycle time (t_{CYC}) is maintained, it is not necessary to check for this flag before each command. This makes vast improvements in MPU processing capabilities possible.

Display Data RAM

Display Data RAM

The display data RAM is RAM that stores the dot data for the display. It has a $65(8 \text{ page} * 8 \text{ bit} + 1) * 132 \text{ bit}$ structure. It is possible to access the desired bit by specifying the page address and the column address. Because, as is shown in Figure3, the D7 to D0 display data from the MPU corresponds to the liquid crystal display common direction, there are few constraints at the time of display common direction, and there are few constraints at the time of display data transfer when multiple NT7532 chips are used, thus display structures can be created easily and with a high degree of freedom. Moreover, reading from and writing to the display RAM from the MPU side is performed through the I/O buffer, which is an independent operation from signal reading for the liquid crystal driver. Consequently, even if the display data RAM is accessed asynchronously during the liquid crystal display, it will not cause adverse effects on the display (such as flickering).

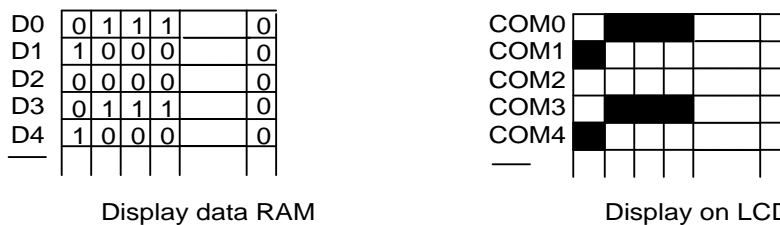
Figure. 3

The Page Address Circuit

As shown in Figure 4, the page address of the display data RAM is specified through the Page Address Set Command. The page address must be specified again when changing pages to perform access.

Page address8 (D3, D2, D1, D0 = 1, 0, 0, 0,) is the page for the RAM region used; only display data D0 is used.

The Column Address

As shown in Figure 4, the display data RAM column address is specified by the Column Address Set command. The specified column address is incremented (+1) with each display data read / write command. This allows the MPU display data to be accessed continuously. Moreover, the incrimination of column addresses stops with 83H, because the column address is independent of the page address. Thus, when moving, for example, from page0 column 83H to page 1 column 00H, it is necessary to specify both the page address and the column address.

Furthermore, as shown in Table 4, the ADC command (segment driver direction select command) can be used to reverse the relationship between the display data RAM column address and the segment output. Because of this, the constraints on the IC layout when the LCD module is assembled can be minimized.

Table. 4

SEG Output	SEG0		SEG131
ADC = "0"	0 (H)→	Column Address	→83 (H)
ADC = "1"	83 (H)←	Column Address	←0 (H)

The Line Address Circuit

The line address circuit, as shown in Table 4, specifies the line address relating to the COM output when the contents of the display data RAM are displayed. Using the display start line address set command, what is normally the top line of the display can be specified. This is the COM0 output when the common output mode is normal and the COM63 output for NT7532, when the common output mode is reversed. The display area is a 65-line area for the NT7532 from the display start line address. If the line addresses are changed dynamically using the display start line address set command, then screen scrolling, page swapping, etc. can be performed.

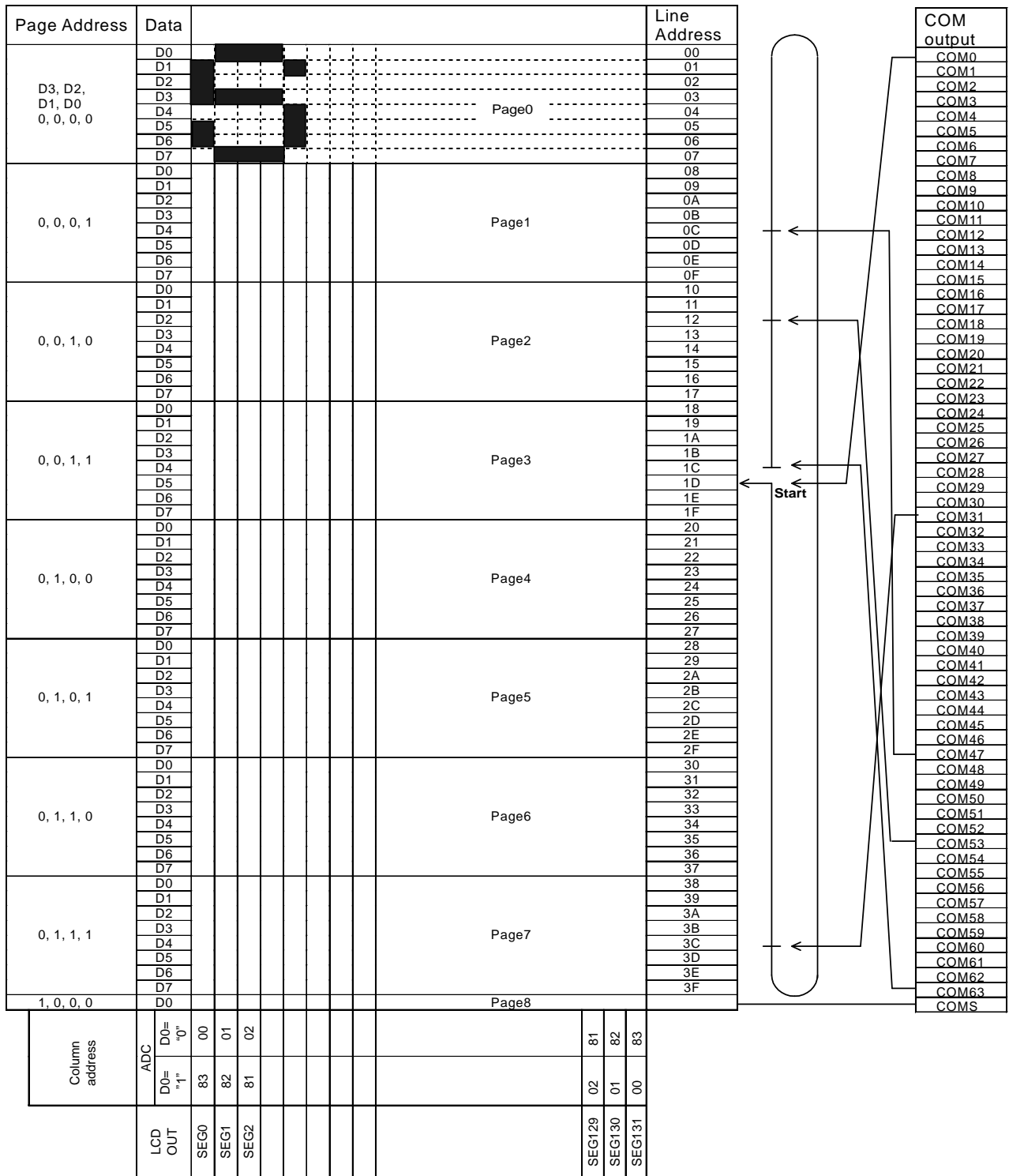
Relationship between display data RAM and address (if initial display line is 1DH)

Figure. 4

The Display Data Latch Circuit

The display data latch circuit is a latch that temporarily stores the display data that is output to the liquid crystal driver circuit from the display data RAM.

Because the display normal/reverse status, display ON/OFF status, and display all points ON/OFF commands control only the data within the latch, they do not change the data within the display data RAM themselves.

The Oscillator Circuit

This is a CR-type oscillator that produces the display clock. The oscillator circuit is only enabled when M/S = "H" and CLS = "H".

When CLS = "L" the oscillation stops, and the display clock is input through the CL terminal.

Display Timing Generator Circuit

The display timing generator circuit generates the timing signal to the line address circuit and the display data latch circuit using the display clock. The display data is latched into the display data latch circuit synchronized with the display clock, and is output to the data driver output terminal. Reading to the display data liquid crystal driver circuits is completely independent of access to the display data RAM by the MPU. Consequently, even if the display data RAM is accessed asynchronously during liquid crystal display, there are absolutely no adverse effects (such as flickering) on the display.

Moreover, the display timing generator circuit generates the common timing and the liquid crystal alternating current signal (FR) from the display clock. It generates a driving waveform using a 2-frame alternating current drive method, as is shown in Figure 5, for the liquid crystal drive circuit.

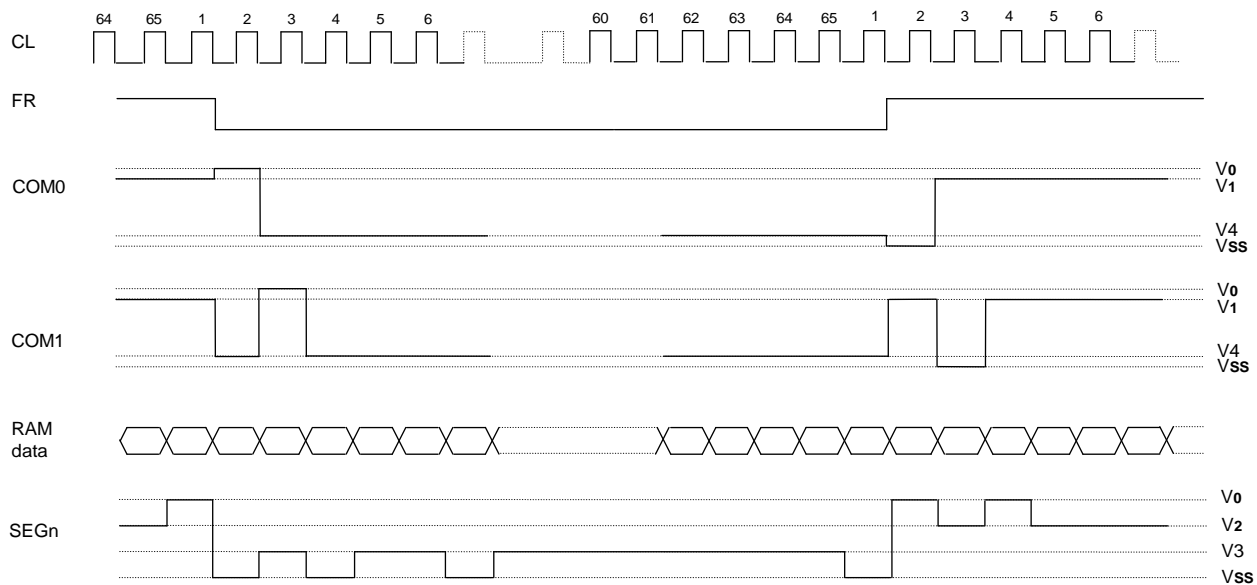

Figure. 5

When multiple NT7532 chips are used, the slave chips must be supplied with the display timing signals (FR, CL, /DOF) from the master chip.

Table 5 shows the status of the FR, CL, and /DOF signals.

Table. 5

Operating Mode		FR	CL	/DOF
Master (M/S = "H")	The internal oscillator circuit is enabled (CLS = "H")	Output	Output	Output
	The internal oscillator circuit is disabled (CLS = "L")	Output	Input	Output
Slave (M/S = "L")	The internal oscillator circuit is disabled (CLS = "H")	Input	Input	Input
	The internal oscillator circuit is disabled (CLS = "L")	Input	Input	Input

Table 6 shows the relationship between oscillation frequency and frame frequency

Table. 6

Duty	Item	f_{CL}	f_{FR}
1/65	On-chip oscillator is used	$f_{osc}/6$	$f_{CL}/(2 \times 65)$
	On-chip oscillator is not used	External input f_{CL}	$f_{CL}/(2 \times 65)$
1/55	On-chip oscillator is used	$f_{osc}/8$	$f_{CL}/(2 \times 55)$
	On-chip oscillator is not used	External input f_{CL}	$f_{CL}/(2 \times 55)$
1/49	On-chip oscillator is used	$f_{osc}/8$	$f_{CL}/(2 \times 49)$
	On-chip oscillator is not used	External input f_{CL}	$f_{CL}/(2 \times 49)$
1/33	On-chip oscillator is used	$f_{osc}/12$	$f_{CL}/(2 \times 33)$
	On-chip oscillator is not used	External input f_{CL}	$f_{CL}/(2 \times 33)$

Common Output Control Circuit

This circuit controls the relationship between the number of common output and specified duty ratio. Common output mode select instruction specifies the scanning direction of the common output pads.

Table. 7

Duty	Status	Common output pads								
		COM [0-15]	COM [16-23]	COM [24-26]	COM [27-36]	COM [37-39]	COM [40-47]	COM [48-63]	COMS	
1/33	Normal	COM[0-15]	NC					COM[16-31]	COMS	
	Reverse	COM[31-16]	NC					COM[15-0]		
1/49	Normal	COM[0-23]		NC			COM[24-47]		COMS	
	Reverse	COM[47-24]		NC			COM[23-0]			
1/55	Normal	COM[0-26]			NC	COM[27-53]			COMS	
	Reverse	COM[53-27]			NC	COM[26-0]				
1/65	Normal	COM[0-63]								COMS
	Reverse	COM[63-0]								

This is a 197-channel multiplex that generates voltage levels for driving the liquid crystal. The combination of the display data, the COM scans signals, and the FR signal produces the liquid crystal drive voltage output.

Figure 6 shows an example of the SEG and COM output waveforms.

Configuration Setting

The NT7532 has two optional configurations, which are configured by DUTY0, DUTY1

DUTY1, DUTY0	Common	Segment	V1	V2	V3	V4
1, 1	65	132	8/9V0, 6/7V0	7/9V0, 5/7V0	2/9V0, 2/7 V0	1/9V0, 1/7V0
1, 0	55	132	7/8V0, 5/6V0	6/8V0, 4/6V0	2/8V0, 2/6 V0	1/8V0, 1/6V0
0, 1	49	132	7/8V0, 5/6V0	6/8V0, 4/6V0	2/8V0, 2/6 V0	1/8V0, 1/6V0
0, 0	33	132	5/6V0, 4/5V0	4/6V0, 3/5V0	2/6 V0, 2/5V0	1/6V0, 1/5V0

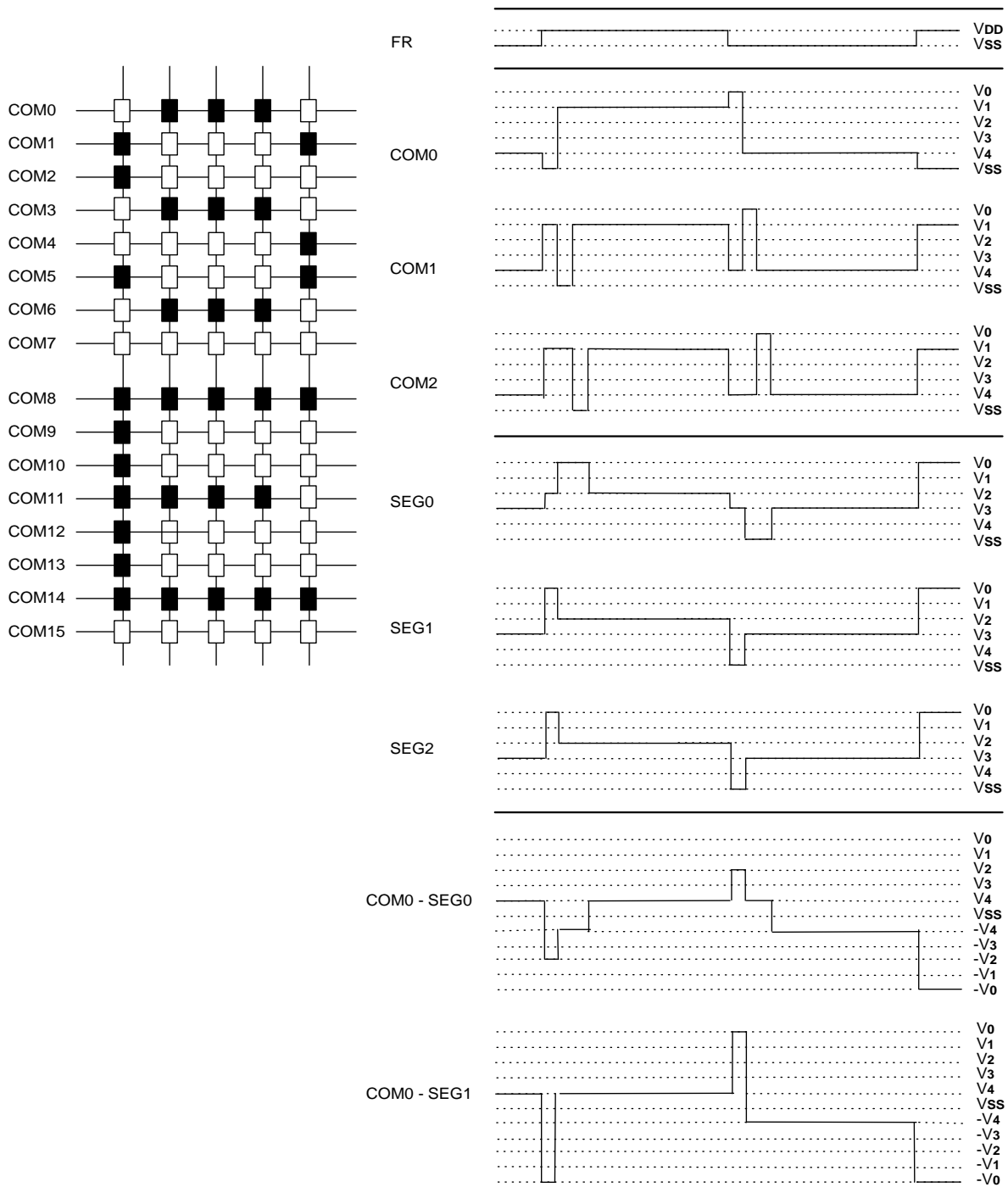
Figure. 6

The Power Supply Circuit

The power supply circuits are low-power consumption power supply circuits that generate the voltage levels required for the liquid crystal drivers. They comprise Booster circuits, voltage regulator circuits, and voltage follower circuits. They are only enabled in master operation.

The power supply circuits can turn the Booster circuits, the voltage regulator circuits, and the voltage follower circuits ON or OFF independently through the use of the Power Control Set commands. Consequently, it is possible to make an external power supply and the internal power supply function somewhat in parallel. Table 8 shows the Power Control Set Command 3-bit data control functions, and Table 9 shows combinations as a reference.

Table. 8 The Control Details of Each Bit of the Power Control Set Command

Item	Status	
	"1"	"0"
D2 Booster circuit control bit	ON	OFF
D1 Voltage regulator circuit (V regulator circuit)	ON	OFF
D0 Voltage follower circuit (V/F circuit) control bit	ON	OFF

Table. 9

Use Settings	D2	D1	D0	Step-up circuit	Voltage regulator circuit	V/F circuit	External voltage input	Step-up voltage system terminal
Only the internal power supply is used	1	1	1	O	O	O	V_{DD2}	Used
Only the V regulator circuit and the V/F circuit are used	0	1	1	X	O	O	V_{OUT}, V_{DD2}	Open
Only the V/F circuit is used	0	0	1	X	X	O	V_0, V_{DD2}	Open
Only the external power supply is used	0	0	0	X	X	X	V_0 to V_4	Open

*The "step-up system terminals" refer to CAP1+, CAP1-, CAP2+, CAP2- and CAP3+.

*While other combinations, not shown above, are also possible, these combinations are not recommended because they have no practical use.

The Step-up Voltage Circuits

Using the step-up voltage circuits within the NT7532 chips it is possible to produce 4X, 3X, 2X step-ups of the V_{DD2} - V_{SS} voltage levels.

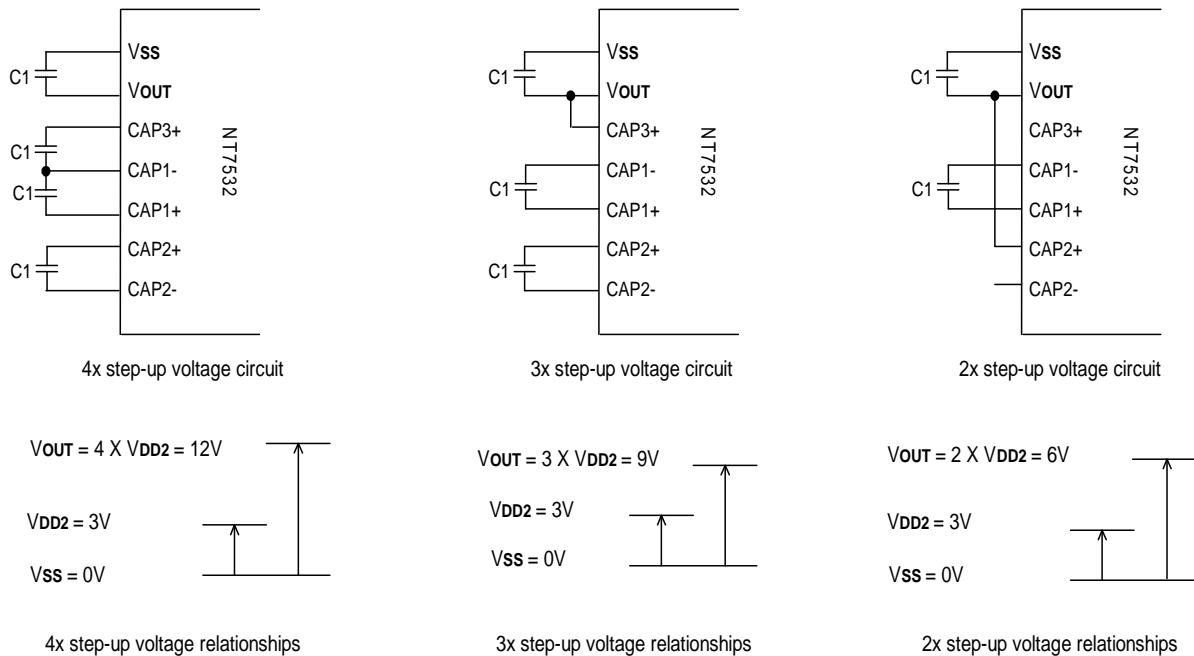

Figure. 7

The Voltage Regulator Circuit

The step-up voltage generated at V_{OUT} outputs the liquid crystal driver voltage V_0 through the voltage regulator circuit. Because the NT7532 chips have an internal high-accuracy fixed voltage power supply with a 64-level electronic volume function and internal resistors for the V_0 voltage regulator, systems can be constructed without having to include high-accuracy voltage regulator circuit components.

Moreover, in the NT7532, two types of thermal gradients have been prepared as VREG options: (1) approximately $-0.05\%/^{\circ}C$ and (2) external input (supplied to the VEXT terminal).

When the V0 Voltage Regulator Internal Resistors are used

Through the use of the V0 voltage regulator internal resistors and the electronic volume function the liquid crystal power supply voltage V0 can be controlled by commands alone (without adding any external resistors), making it possible to adjust the liquid crystal display brightness. The V0 voltage can be calculated using equation A-1 over the range where $V_0 < V_{OUT}$.

$$V_0 = (1 + R_b/R_a) * V_{EV} = (1 + R_b/R_a) * (1 - (63 - \alpha)/162) * V_{REG} \quad (\text{Equation A-1})$$

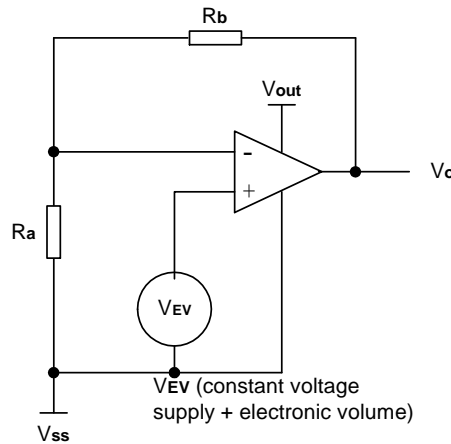

VREG is the IC internal fixed voltage supply, and its voltage at $T_a = 25^\circ\text{C}$ is shown in Table 10.

Table. 10

Equipment Type	VRS	Thermal Gradient	Units	VREG
Internal power Supply	1	-0.05	%/°C	2.1
External input	0	-	-	VEXT

α is set to 1 level of 64 possible levels by the electronic volume function depending on the data set in the 6-bit electronic volume register. Table 10 shows the value for α depending on the electronic volume register settings. R_a/R_b is the V0 voltage regulator internal resistor ratio, and can be set to 8 different levels through the V0 voltage regulator internal resistor ratio set command. The $(1 + R_b/R_a)$ ratio assumes the values shown in Table 11 depending on the 3-bit data settings in the V0 voltage regulator internal resistor ratio register.

Table. 11

D5	D4	D3	D2	D1	D0	α	V0
0	0	0	0	0	0	0	Minimum
0	0	0	0	0	1	1	:
0	0	0	0	1	0	2	:
		:			:	:	:
1	0	0	0	0	0	32 (default)	:
		:			:	:	:
1	1	1	1	1	0	62	:
1	1	1	1	1	1	63	Maximum

V0 voltage regulator internal resistance ratio register value and $(1 + R_b/R_a)$ ratio (Reference value)

Table. 12

Register			Equipment Type by Thermal Gradient [Units: %/ °C]	
D2	D1	D0	-0.05 %/°C	VREG External Input
0	0	0	3.0	1.5
0	0	1	3.5	2.0
0	1	0	4.0	2.5
0	1	1	4.5	3.0
1	0	0	5.0	3.5
1	0	1	5.5	4.0
1	1	0	6.0	4.5
1	1	1	6.4	5.0

The V0 voltage as a function of the V0 voltage regulator internal resistor ratio register and the electronic volume register.

Setup example:

When selecting $T_a = 25^\circ\text{C}$ and $V_0 = 7\text{V}$ for an NT7532 model on which the temperature compensation is internal, using the equation A-1, the following setup is enabled.

Table. 13

Contents	Register					
	D5	D4	D3	D2	D1	D0
For V0 voltage regulator	-	-	-	0	1	0
Electronic Volume	1	0	0	1	0	1

- When the V0 voltage regulator internal resistors or the electronic volume function is used, it is necessary to at least set the voltage regulator circuit and the voltage follower circuit to an operating mode using the power control set commands. Moreover, it is necessary to provide a voltage from V_{OUT} when the Booster circuit is OFF.
- The VR terminal is enabled only when the V0 voltage regulator internal resistors are not used (i.e. the IRS terminal = "L"). When the V0 voltage regulator internal resistors are used (i.e. when the IRS terminal = "H"), then the VR terminal is left open.
- Because the input impedance of the VR terminal is high, it is necessary to take into consideration short leads, shield cables, etc. to handle noise.

The Liquid Crystal Voltage Generator Circuit

The V0 voltage is produced by a resistive voltage divider within the IC, and can be produced at the V1, V2, V3, and V4 voltage levels required for liquid crystal driving. Moreover, when the voltage follower changes the impedance, it provides V1, V2, V3, and V4 to the liquid crystal drive circuit. 1/9 bias or 1/7 bias for NT7532 can be selected.

High Power Mode

The power supply circuit equipped in the NT7532 chips has very low power consumption (normal mode: /HPM= "H"). However for LCDs or panels with large loads, this low-power power supply may cause the display quality to degrade. When this occurs, setting the /HPM terminal to "L" (high power mode) can improve the quality of the display. We recommend that the display be checked on actual equipment to determine whether or not to use this mode.

Moreover, if the improvement to the display is inadequate even after the high power mode has been set, then it is necessary to add a command sequence when the built-in power supply is turned OFF

To turn off the built-in power supply, follow the command sequence as shown below to turn it off after making the system enter standby mode.

Reference Power Supply Circuit for Driving LCD Panel

-When using all LCD power circuits
(Voltage converter regulator and follower)
(In case of 3X boosting circuit)

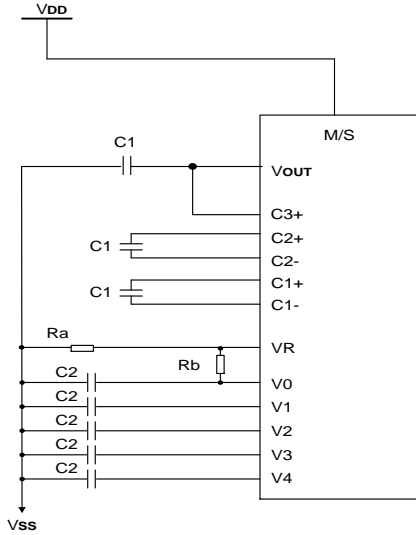

-When not using voltage booster circuits

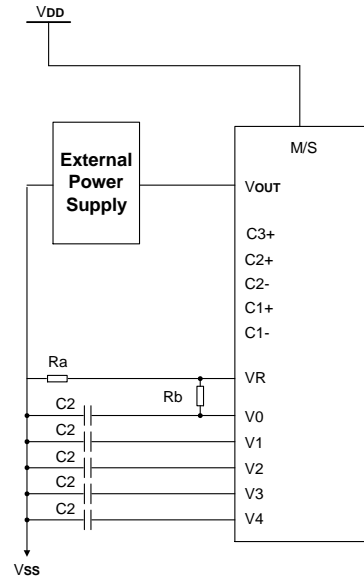

-When only using voltage follower

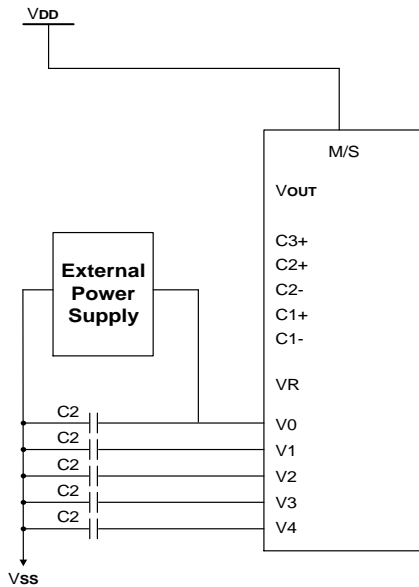

-When not using internal LCD power supply circuits

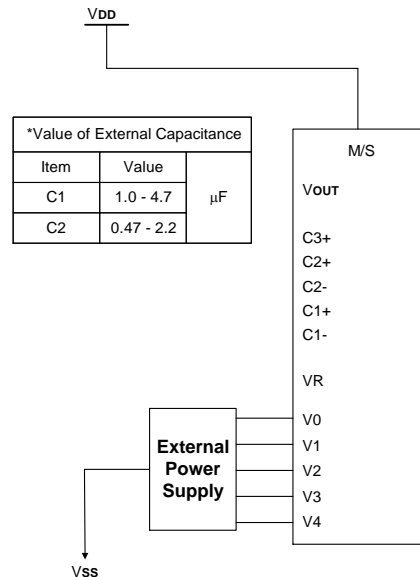

Reset Circuit

When the /RES input falls to “L”, these LSI reenter their default state. The default settings are shown below:

1. Display OFF
2. Normal display
3. ADC select: Normal display (ADC command D0 = “L”)
4. Power control register (D2, D1, D0) = (0, 0, 0,)
5. Register data clear in serial interface
6. LCD power supply bias ratio 1/9 (1/65 duty), 1/8 (1/55, 1/49 duty), 1/6 (1/33 duty)
7. Read modify write OFF
8. Static indicator: OFF
Static indicator register: (D1, D2) = (0, 0)
9. Display start line register set at first line
10. Column address counter set at address 0
11. Page address register set at page 0
12. Common output status normal
13. V0 voltage regulator internal power supply ratio set mode clear:
V0 voltage regulator internal resistor ratio register: (D2, D1, D0) = (1, 0, 0)
14. Electronic volume register set mode clear
Electronic volume register: (D5, D4, D3, D2, D1, D0) = (1, 0, 0, 0, 0, 0,)
15. Test mode clear
16. All-indicator-lamps-on OFF (All-indicator-lamps ON/OFF command D0 = “L”)
17. Output condition of COM, SEG
COM: V1
SEG: V2

On the other hand, when the reset command is used only default settings 7 to 15 above are put into effect. The MPU interface (Reference Example), the /RES terminal is connected to the MPU reset terminal, making the chip reinitialize simultaneously with the MPU. At the time of power up, it is necessary to reinitialize using the /RES terminal. Moreover, when the control signal from the MPU is in a high impedance state, there may be an overcurrent condition; therefore, take measures to prevent the input terminal from entering a high impedance state.

In the NT7532, if the internal liquid crystal power supply circuit is not used, then it is necessary to apply an “L” signal to the /RES terminal when the external liquid crystal power supply is applied.

Even though the oscillator circuit operates while the /RES terminal is “L,” the display timing generator circuit is stopped, and the FR, FRS, and /DOF terminals are fixed to “H,” and the CL pin is fixed to “H” only when the internal oscillator circuit is used. There is no influence on the D0 to D7 terminals.

Commands

The NT7532 uses a combination of A0, /RD(E) and /WR (R/W) signals to identify data bus signals. As the chip analyzes and executes each command using the internal timing clock only, regardless of the external clock, its processing speed is very high and its busy check is usually not required. The 8080 series microprocessor interface enters a read status when a low pulse is input to the /RD pad and a write status when a low pulse is input to the /WR pad. The 6800 series microprocessor interface enters a read status when a high pulse is input to the R/W pad and a write status when a low pulse is input to this pad. When a high pulse is input to the E pad, the command is activated. (For timing, see AC Characteristics). Accordingly, in the command explanation and command table, (E) becomes 1(high) when the 6800 series microprocessor interface reads status of display data. This is the only different point from the 8080 series microprocessor interface.

Taking the 8080 series microprocessor interface as an example, commands are explained below.

When the serial interface is selected, input data starting from D7 in sequence.

Command Set

1. Display ON/OFF

Alternatively turns the display on and off.

A0	E /RD	R/W /WR	D7	D6	D5	D4	D3	D2	D1	D0	Setting
0	1	0	1	0	1	0	1	1	1	1	Display ON
										0	Display OFF

When the display OFF command is executed when in the display all points ON mode, the power save mode is entered. See the section on the power saver for details.

2. Set Display Start Line

Specifies line address (refer to Figure 4) to determine the initial display line, or COM0. The RAM display data becomes the top line of the LCD screen. The higher number of lines in ascending order, corresponding to the duty cycle follows it. This command changes when the line address, smooth scrolling or a page change take place.

A0	E /RD	R/W /WR	D7	D6	D5	D4	D3	D2	D1	D0
0	1	0	0	1	A5	A4	A3	A2	A1	A0

← High-order bit

A5	A4	A3	A2	A1	A0	Line address
0	0	0	0	0	0	0
0	0	0	0	0	1	1
0	0	0	0	1	0	2
			:			:
1	1	1	1	1	0	62
1	1	1	1	1	1	63

3. Set Page Address

Specifies the page address to load display RAM data to page address register. Any RAM data bit can be accessed when its page address and column address are specified. The display remains unchanged even when the page address is changed. Page address 8 is the display RAM area dedicated to the indicator, and only D0 is valid for data change.

A0	E /RD	R/W /WR	D7	D6	D5	D4	D3	D2	D1	D0
0	1	0	1	0	1	1	A3	A2	A1	A0

A3	A2	A1	A0	Page address
0	0	0	0	0
0	0	0	1	1
0	0	1	0	2
0	0	1	1	3
0	1	0	0	4
0	1	0	1	5
0	1	1	0	6
0	1	1	1	7
1	0	0	0	8

4. Set Column Address

It specifies column address of display RAM. It divides the column address into 4 higher bits and 4 lower bits. Set each of them in succession. When the microprocessor repeats to access the display RAM, the column address counter is incremental during each access until address 132 is accessed. The page address is not changed during this time.

	A0	E /RD	R/W /WR	D7	D6	D5	D4	D3	D2	D1	D0
Higher bits	0	1	0	0	0	0	1	A7	A6	A5	A4
Lower bits	0	1	0	0	0	0	0	A3	A2	A1	A0

A7	A6	A5	A4	A3	A2	A1	A0	Line address
0	0	0	0	0	0	0	0	0
0	0	0	0	0	0	0	1	1
			:					:
1	0	0	0	0	0	1	1	131

5. Read Status

A0	E /RD	R/W /WR	D7	D6	D5	D4	D3	D2	D1	D0
0	0	1	BUSY	ADC	ON/OFF	RESET	0	0	0	0

Busy: When high, the NT7532 is busy due to the internal operation or reset. Any command is rejected until BUSY becomes low. The busy check is not required if enough time is provided for each cycle.

ADC: Indicates the relationship between RAM column address and segment drivers. When low, the display is reversed and column address “131-n” corresponds to segment driver n. when high, the display is normal and column address corresponds to segment driver n.

ON/OFF: Indicates whether the display is on or off. When low, the display turns on. When high, the display turns off. This is the opposite of Display ON/OFF command

RESET: Indicates that the initialization is in progress by /RES signal or by reset command. When low, the display is on. When high, the chip is reset.

6. Write Display Data

Write 8-bit data in display RAM. As the column address automatically increments by 1 after each write, the microprocessor can continue to write data of multiple words.

A0	E /RD	R/W /WR	D7	D6	D5	D4	D3	D2	D1	D0
1	1	0	Write data							

7. Read Display Data

Reads 8-bit data from display RAM area specified by column address and page address. As the column address automatically increments by 1 after each write, the microprocessor can continue to read data of multiple words. A single dummy read is required immediately after the column address setup. Refer to the display RAM section of the FUNCTIONAL DESCRIPTION for details. Note that no display data can be read via the serial interface.

A0	/RD	/WR	D7	D6	D5	D4	D3	D2	D1	D0
1	0	1	Read data							

8. ADC Select

Changes the relationship between RAM column address and segment driver. The order of segment driver output pads can be reversed by software. This allows flexible IC layout during LCD module assembly. For details, refer to the column address section of Figure4. When display data is written or read, the column address is incremented by 1 as shown in Figure4.

A0	E /RD	R/W /WR	D7	D6	D5	D4	D3	D2	D1	D0
0	1	0	1	0	1	0	0	0	0	D

When D is low, rotation is to the right (normal direction)

When D is high, rotation is to the left (reverse direction)

9. Normal/ Reverse Display

Reverses the Display ON/OFF status without rewriting the contents of the display data RAM.

A0	E /RD	R/W /WR	D7	D6	D5	D4	D3	D2	D1	D0
0	1	0	1	0	1	0	0	1	1	D

When D is low, the RAM data is high, being LCD ON potential (normal display)

When D is high, the RAM data is low, being LCD ON potential (reverse display)

10. Entire Display ON

Forcibly turns the entire display on regardless of the contents of the display data RAM. At this time, the contents of the display data RAM are held.

This command has priority over the Normal/Reverse Display command. When D is low, the normal display status is provided.

A0	E /RD	R/W /WR	D7	D6	D5	D4	D3	D2	D1	D0
0	1	0	1	0	1	0	0	1	0	D

When D is high, the entire display ON status is provided. If the Entire Display ON command is executed in the display OFF status, the LCD panel enters Power save mode. Refer to the Power Save section for details.

11. Set LCD Bias

This command selects the voltage bias ratio required for the liquid crystal display.

A0	E /RD	R/W /WR	D7	D6	D5	D4	D3	D2	D1	D0	Duty			
											1/33	1/49	1/55	1/65
0	1	0	1	0	1	0	0	0	1	0	1/6 bias	1/8 bias	1/8 bias	1/9 bias
											1/5 bias	1/6 bias	1/6 bias	1/7 bias

12. Read-Modify-Write

A pair of Read-Modify-Write and End commands must always be used. Once Read-Modify-Write is issued, the column address is not incremental by Read Display Data command but incremental by Write Display Data command only. It continues until the End command is issued. When the End is issued, the column address returns to the address when Read-Modify-Write is issued. This can reduce the microprocessor load when data of a specific display area is repeatedly changed when the cursor is blinking or other events.

A0	E /RD	R/W /WR	D7	D6	D5	D4	D3	D2	D1	D0
0	1	0	1	1	1	0	0	0	0	0

Note: Any command except Read/Write Display Data and Set Column Address can be issued during Read-Modify-Write mode.

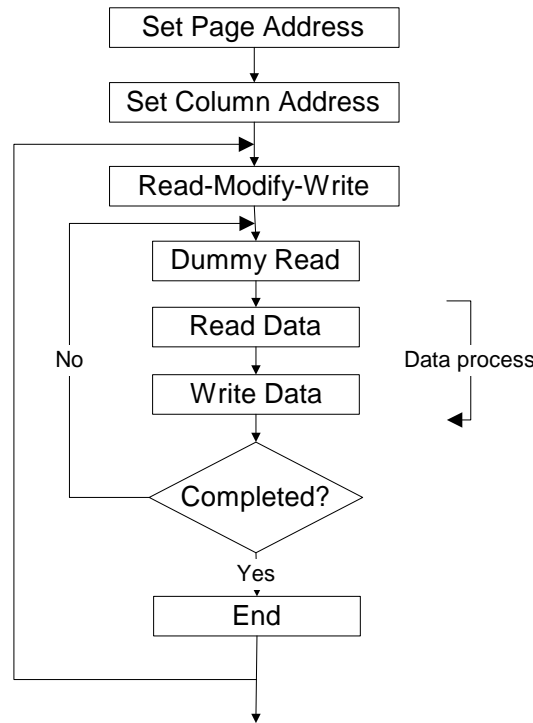
Cursor display sequence

13. End

Cancels Read-Modify-Write mode and returns column address to the original address (when Read-Modify-Write is issued).

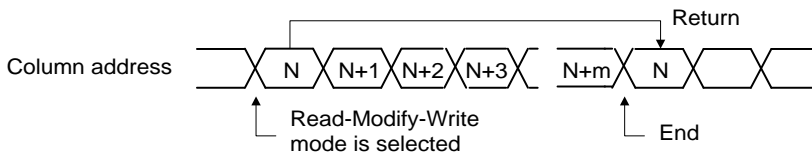
A0	E /RD	R/W /WR	D7	D6	D5	D4	D3	D2	D1	D0
0	1	0	1	1	1	0	1	1	1	0

14. Reset

This command resets the Display Start Line register, Column Address counter, Page Address register, and Common output mode register, the V0 voltage regulator internal resistor ratio register, the Electronic Volume register, the static indicator mode register, the read-modify-write mode register, and the test mode. The Reset command does not affect the contents of display RAM. Refer to the Reset circuit section of Function Description.

A0	E /RD	R/W /WR	D7	D6	D5	D4	D3	D2	D1	D0
0	1	0	1	1	1	0	0	0	1	0

The Reset command cannot initialize the LCD power supply. Only the Reset signal to the /RES pad can initialize the supplies.

15. Output Status Select Register

Applicable to the NT7532. When D is high or low, the scan direction of the COM output pad is selectable. Refer to Output Status Selector Circuit in Function Description for details.

A0	E /RD	R/W /WR	D7	D6	D5	D4	D3	D2	D1	D0
0	1	0	1	1	0	0	D	*	*	*

D: Selects the scan direction of COM output pad

D = 0: Normal (COM0 → COM63/53/47/31)

D = 1: Reverse (COM63/53/47/31 → COM0)

*: Invalid bit

16. Set Power Control

Selects one of eight-power circuit functions using a 3-bit register. An external power supply and part of on-chip power circuit can be used simultaneously. Refer to the Power Supply Circuit section of the FUNCTIONAL DESCRIPTION for details.

A0	E /RD	R/W /WR	D7	D6	D5	D4	D3	D2	D1	D0
0	1	0	0	0	1	0	1	A2	A1	A0

When A0 is low, the voltage follower turns off. When A0 is high, it turns on.

When A1 is low, the voltage regulator turns off. When A1 is high, it turns on.

When A2 is low, the voltage booster turns off. When A2 is high, it turns on.

17. V0 Voltage Regulator Internal Resistor Ratio Set

This command sets the V0 voltage regulator internal resistor ratio. For details, see explanation under “The Power Supply Circuits”.

A0	E /RD	R/W /WR	D7	D6	D5	D4	D3	D2	D1	D0	Rb / Ra Ratio
0	1	0	0	0	1	0	0	0	0	0	Small
								0	0	1	
								0	1	0	
								:	:	:	
								1	1	0	
1	1	1	Large								

18. The Electronic Volume (Double Byte Command)

This command makes it possible to adjust the brightness of the liquid crystal display by controlling the liquid crystal drive voltage V0 through the output from the voltage regulator circuits of the internal liquid crystal power supply.

This command is a double byte command used as a pair with the electronic volume mode set command and the electronic volume register set command, and both commands must be issued one after the other.

The Electronic Volume Mode Set

When this command is input, the electronic volume register set command is enabled. Once the electronic volume mode has been set, no other command except for the electronic volume register command can be used. Once the electronic volume register set command has been used to set data into the register, then the electronic volume mode is released.

A0	E /RD	R/W /WR	D7	D6	D5	D4	D3	D2	D1	D0
0	1	0	1	0	0	0	0	0	0	1

Electronic Volume Register Set

By using this command to set six bits of data to the electronic volume register, the liquid crystal voltage V0 assumes one of the 64 voltage levels.

When this command is input, the electronic volume mode is released after the electronic volume register has been set.

A0	E /RD	R/W /WR	D7	D6	D5	D4	D3	D2	D1	D0	V0
0	1	0	*	*	0	0	0	0	0	0	Small : Large
0	1	0	*	*	0	0	0	0	1	0	
0	1	0	*	*	0	0	0	0	1	1	
0	1	0	*	*			:				
0	1	0	*	*	1	1	1	1	1	0	
0	1	0	*	*	1	1	1	1	1	1	

When the electronic volume function is not used, set D5 - D0 to 100000.

19. Static Indicator (Double Byte Command)

This command controls the static drive system indicator display. The static indicator display is controlled by this command only, and is independent of other display control commands.

This is used when one of the static indicator liquid crystal drive electrodes is connected to the FR terminal, and the other is connected to the FRS terminal. A different pattern is recommended for the static indicator electrodes than for the dynamic drive electrodes. If the pattern is too close, it can result in deterioration of the liquid crystal and of the electrodes.

The static indicator ON command is a double byte command paired with the static indicator registers, and these commands must be executed one after the other. (The static indicator OFF command is a single byte command.)

Static Indicator ON/OFF

When the static indicator ON command is entered, the static indicator register set command is enabled. Once the static indicator ON command has been entered, no other command aside from the static indicator register set command can be used. This mode is cleared when data is set in the register by the static indicator register set command.

A0	E /RD	R/W/ WR	D7	D6	D5	D4	D3	D2	D1	D0
0	1	0	1	0	1	0	1	1	0	D

D = 0: Static Indicator OFF

D = 1: Static Indicator ON

Static Indicator Register Set

These commands set two bits of data into the static indicator register and are used to set the static indicator into a blinking mode.

A0	E /RD	R/W/ WR	D7	D6	D5	D4	D3	D2	D1	D0	Indicator Display State
0	1	0	*	*	*	*	*	*	0	0	OFF
									0	1	ON (blinking at approximately 0.5 second intervals)
									1	0	ON (blinking at approximately 1 second intervals)
									1	1	ON (constantly on)

* Disabled bit

20. Power Save (Compound Command)

When all displays are turned on during display off, the Power Save command is issued to greatly reduce current consumption.

If the static indicators are off, the Power Save command makes the system enter sleep mode. If it is on, this command makes the system enter standby mode.

Release the Sleep mode using the both Power Save OFF command (Display ON command or Entire Display OFF command) and Set Indicator On command.

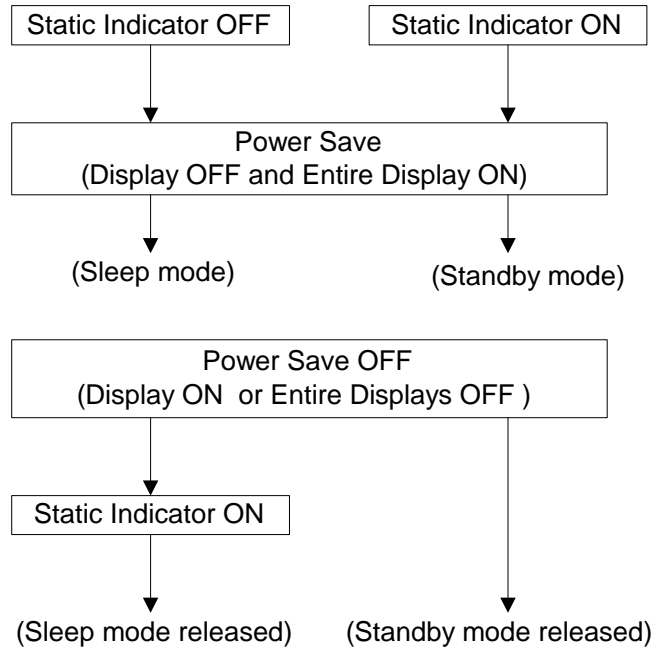

Sleep Mode

This mode stops every operation of the LCD display system, and can reduce current consumption nearly to a static current value if no access is made from the microprocessor. The internal status in the sleep mode is as follows:

- (1) Stops the oscillator circuit and LCD power supply circuit.
- (2) Stops the LCD drives and outputs the V_{SS} level as the segment/common driver output.
- (3) Holds the display data and operation mode provided before the start of the sleep mode.
- (4) The MPU can access the built-in display RAM.

Standby Mode

Stops the operation of the duty LCD displays system and turns on only the static drive system to reduce current consumption to the minimum level required for the static drive.

The ON operation of the static drive system indicates that the NT7532 is in standby mode. The internal status in the standby mode is as follows:

- (1) Stops the LCD power supply circuit.
- (2) Stops the LCD drive and outputs the V_{SS} level as the segment / common driver output. However, the static drive system still operates.
- (3) Holds the display data and operation mode provided before the start of the standby mode.
- (4) The MPU can access the built-in display RAM.

When the RESET command is issued in the standby mode, the sleep mode is set.

- When an external resistive driver gives the LCD driving voltage level, the current of this resistor must be cut so that it may be fixed to floating or V_{SS} level, prior to or concurrently with causing the NT7532 to go to the sleep mode or standby mode.
- When an external power supply is used, likewise, the function of this external power supply must be stopped so that it may be fixed to floating or V_{SS} level, prior to or concurrently with causing the NT7532 to go into sleep mode or standby mode.

21. NOP

Non-Operation Command

A0	E /RD	R/W /WR	D7	D6	D5	D4	D3	D2	D1	D0
0	1	0	1	1	1	0	0	0	1	1

22. Test Command

This is the dedicated IC chip test command. It must not be used for normal operation. If the Test command is issued inadvertently set the /RES input to low or issue the Reset command to release the test mode.

A0	E /RD	R/W /WR	D7	D6	D5	D4	D3	D2	D1	D0
0	1	0	1	1	1	1	*	*	*	*

*: Invalid bit

Cautions: The NT7532 maintains an operation status specified by each command. However, a high level of ambient noise may change the internal operation status. Users must consider how to suppress noise on the package and system or to prevent ambient noise insertion. To prevent a spike in noise, built-in software for periodical status refreshment is recommended.

The test command can be inserted in an unexpected place. Therefore it is recommended to enter the test mode reset command F0h during the refresh sequence.

Command Table

Command	Code											Function
	A0	/RD	/WR	D7	D6	D5	D4	D3	D2	D1	D0	
(1) Display on/off	0	1	0	1	0	1	0	1	1	1	D	Turns on the LCD panel when high, and turns it off when low
(2) Set display start line	0	1	0	0	1	Display start address					Specifies RAM display line for COM0	
(3) Set page address	0	1	0	1	0	1	1	Page address				Sets the display RAM page in Page Address register
(4-1) Set column address 4 higher bits	0	1	0	0	0	0	1	Higher column address				Sets 4 higher bits of column address of display RAM in register
(4-2) Set column address 4 lower bits	0	1	0	0	0	0	0	Lower column address				Sets 4 lower bits of column address of display RAM in register
(5) Read status	0	0	1	Status				0	0	0	0	Reads the status information
(6) Write display data	1	1	0	Write data							Writes data in display RAM	
(7) Read display data	1	0	1	Read data							Reads data from display RAM	
(8) ADC select	0	1	0	1	0	1	0	0	0	0	D	Sets the display RAM address SEG output correspondence
(9) Normal/Reverse display	0	1	0	1	0	1	0	0	1	1	D	Normal indication when low, but full indication when high
(10) Entire display on/off	0	1	0	1	0	1	0	0	1	0	0 1	Selects normal display (0) or Entire Display ON (1)
(11) Set LCD bias	0	1	0	1	0	1	0	0	0	1	D	Sets LCD drive voltage bias ratio
(12) Read-Modify-Write	0	1	0	1	1	1	0	0	0	0	0	Increments Column Address counter during each write
(13) End	0	1	0	1	1	1	0	1	1	1	0	Releases the Read-Modify-Write
(14) Reset	0	1	0	1	1	1	0	0	0	1	0	Resets internal functions
(15) Common output mode select	0	1	0	1	1	0	0	D	*	*	*	Selects COM output scan direction. * Invalid data
(16) Set power control	0	1	0	0	0	1	0	1	Operation status			Selects the power circuit operation mode
(17) V0 voltage regulator internal resistor ratio set	0	1	0	0	0	1	0	0	Resistor ratio			Select internal resistor ratio (Rb / Ra) mode
(18) Electronic volume mode set Electronic Volume Register set	0	1	0	1	0	0	0	0	0	0	1	Sets the V0 output voltage electronic volume register
	0	1	0	*	*	Electronic control value						
(19) Set static indicator On/Off Set Static indicator register	0	1	0	1	0	1	0	1	1	0	D	Sets static indicator On/Off 0: OFF 1: ON
	0	1	0	*	*	*	*	*	*	Mode		Sets the flashing mode

Command Table (Continued)

Command	Code											Function	
	A0	/RD	/WR	D7	D6	D5	D4	D3	D2	D1	D0		
(20) Power save	-	-	-	-	-	-	-	-	-	-	-	-	Compound command of display OFF and entire display ON
(21) NOP	0	1	0	1	1	1	0	0	0	1	1	Command for non-operation	
(22) Test Command	0	1	0	1	1	1	1	*	*	*	*	IC Test command. Do not use!	
(23) Test Mode Reset	0	1	0	1	1	1	1	0	0	0	0	Command of test mode reset	

Note: Do not use any other command, or system malfunction may result.

Command Description

Instruction Setup: Reference

1. Initialization

Note: With this IC, when the power is applied, LCD driving non-selective potentials V2 and V3 (SEG pin) and V1 and V4 (COM pin) are output through the LCD driving output pins SEG and COM. When electric charge is remaining in the smoothing capacitor connecting between the LCD driving voltage output pins (V0 - V4) and the V_{DD} pin, the picture on the display may instantaneously become totally dark when the power is turned on. To avoid such failure, we recommend the following flow sequence when turning on the power.

1.1. When the built-in power is being used immediately after turning on the power:

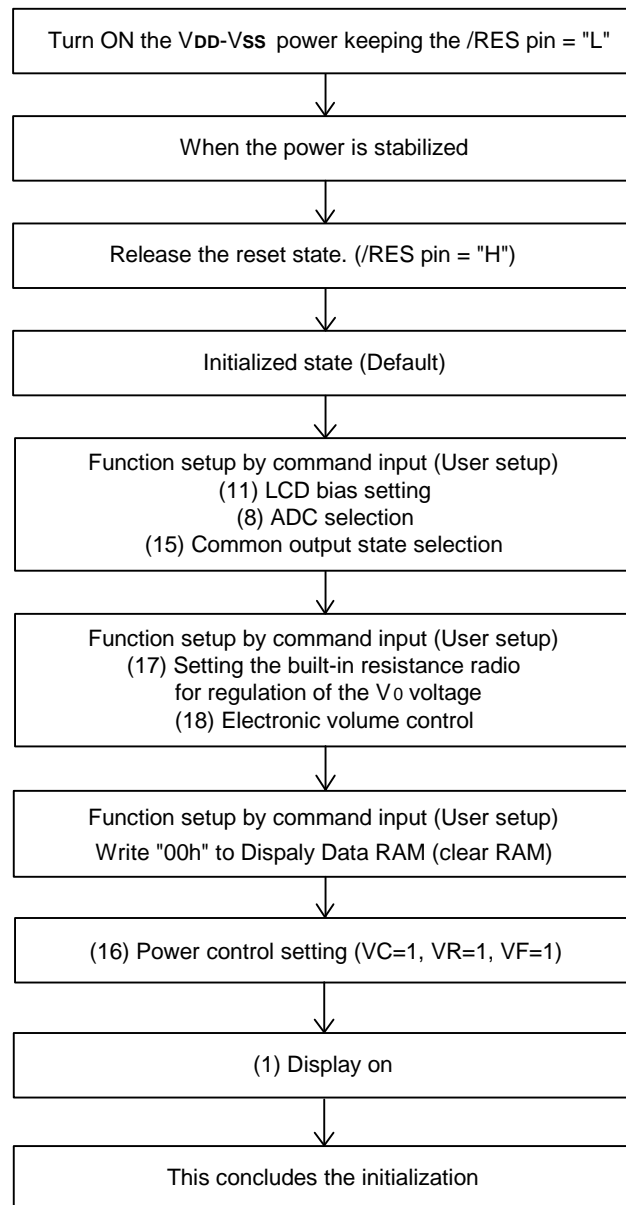

The time of initialization will vary depending on the panel characteristics and capacitance of the smoothing capacitor. Therefore, we suggest you to conduct an operation check using the actual equipment.

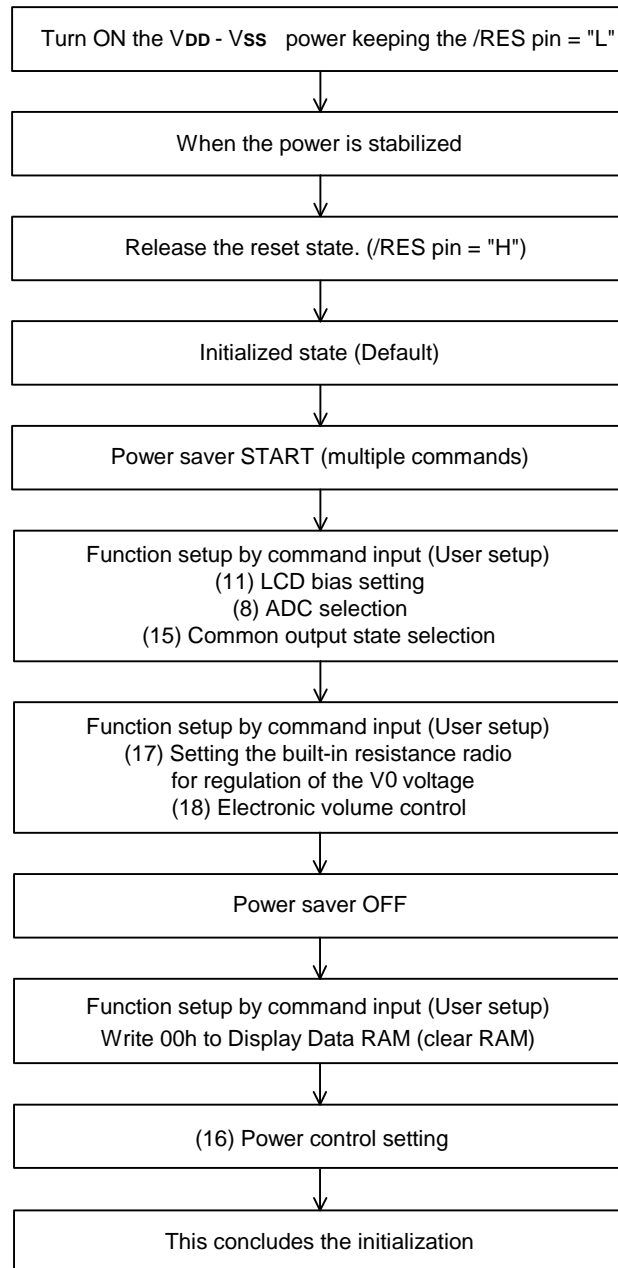
1.2. When the built-in power is not used immediately after turning on the power

The target time of 5ms will vary depending on the panel characteristics and the capacitance of the smoothing capacitor. Therefore, we suggest you conduct an operation check using the actual equipment.

1. Data Display

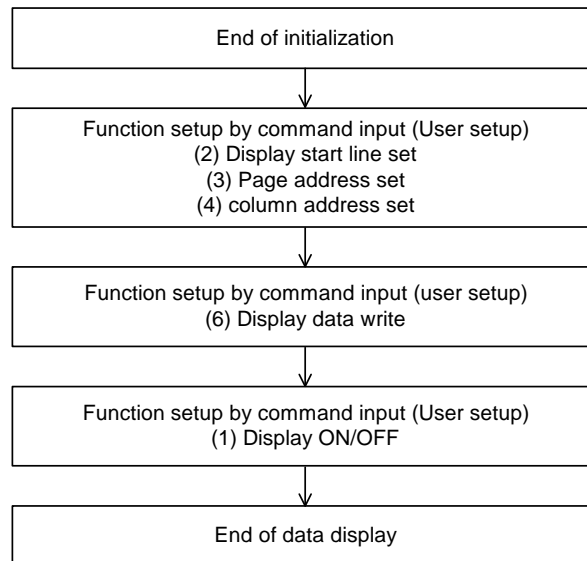

2. Power OFF

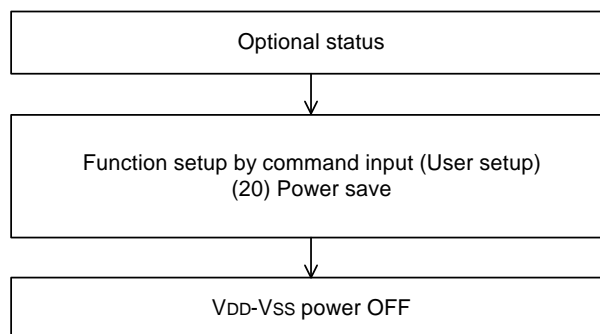

The target time will vary depending on the panel characteristics and capacitance of the smoothing capacitor. Therefore, we suggest you conduct an operation check using the actual equipment.

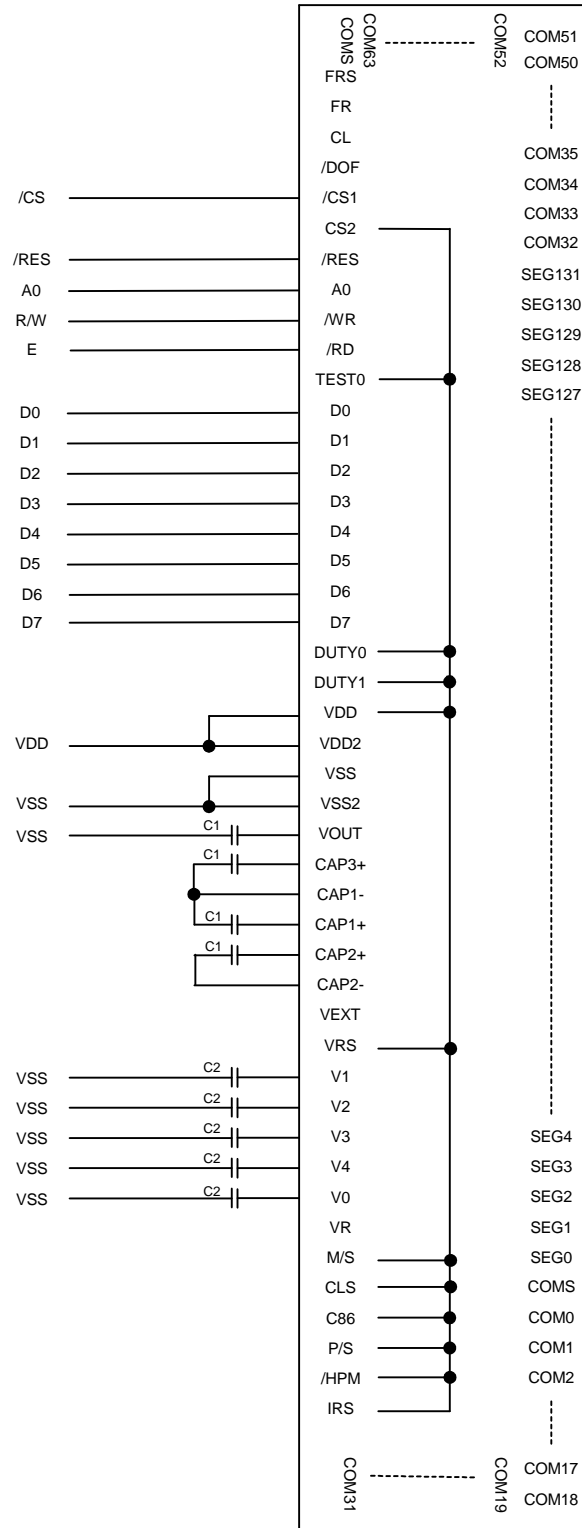
Reference Connection to MPU
6800 series interface (1/65 duty; internal oscillator, Ra & Rb; normal mode)

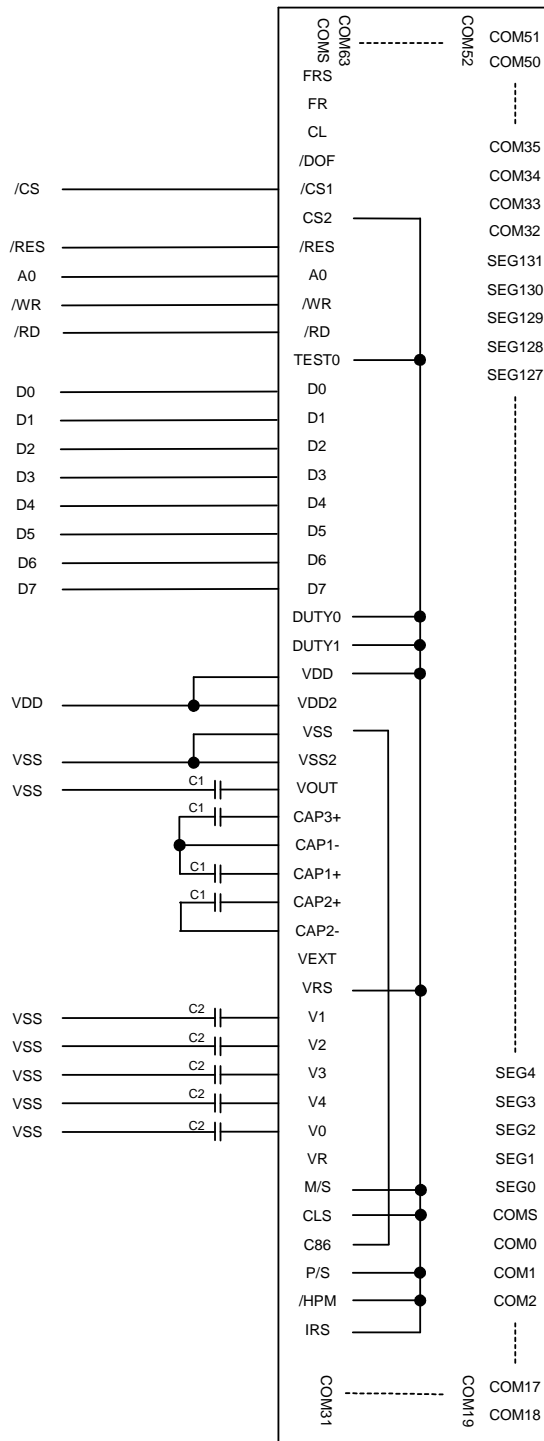
8080 series interface (1/65 duty; internal oscillator, Ra & Rb; normal mode)

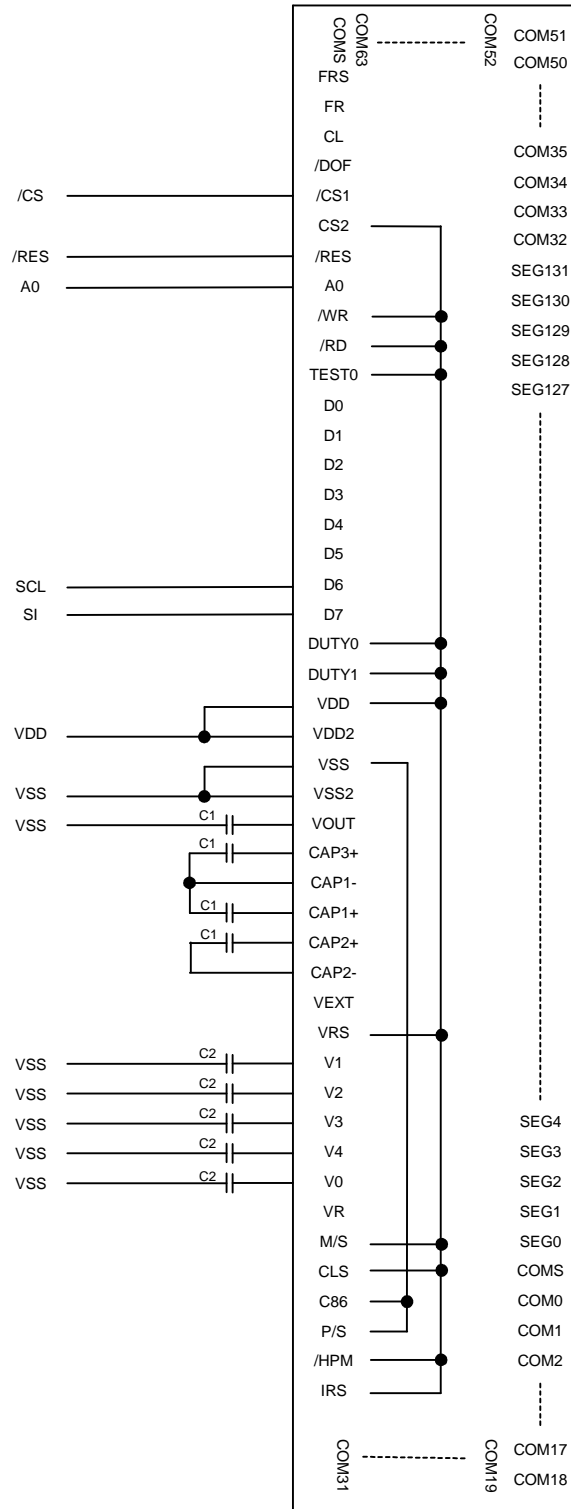
Serial interface (1/65 duty; internal oscillator, Ra & Rb; normal mode)

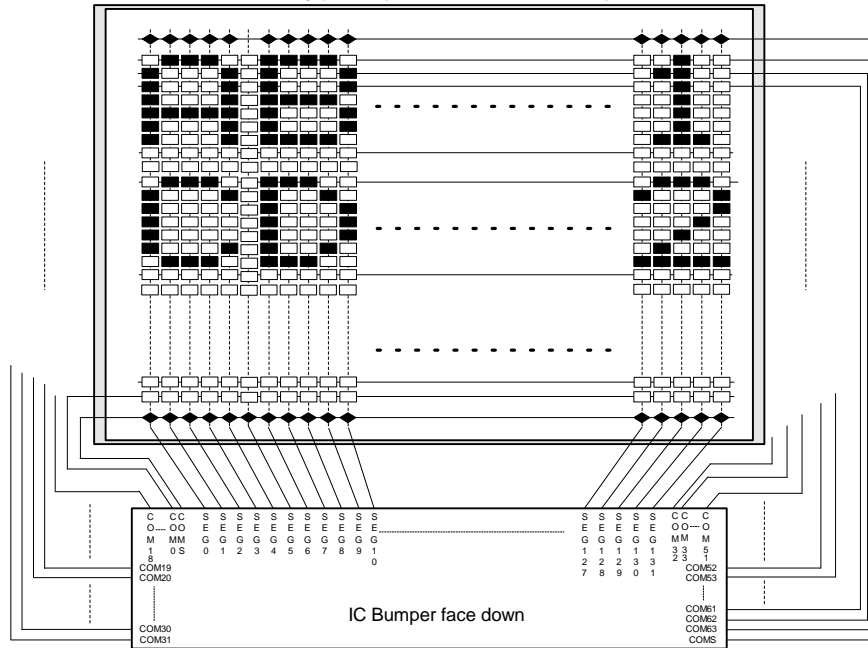
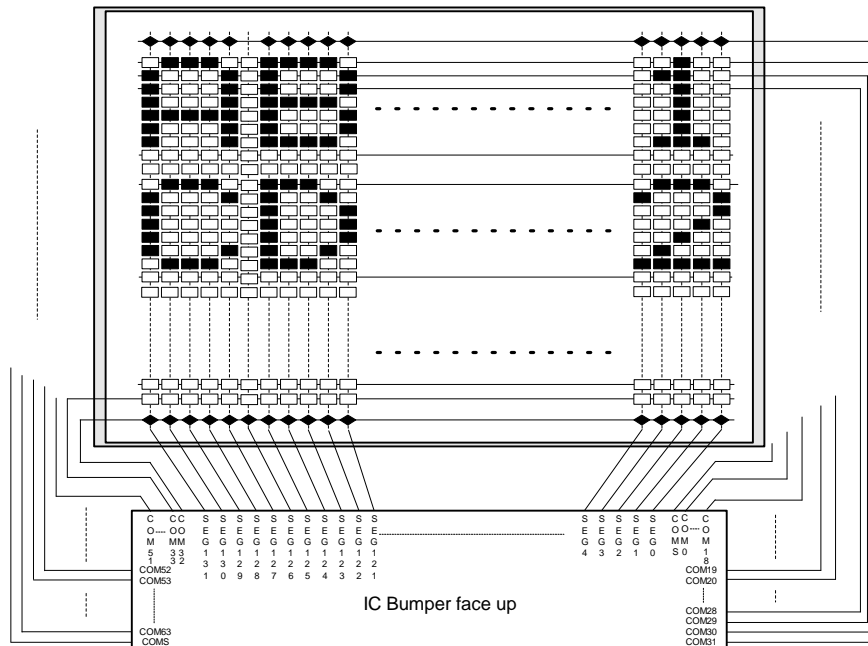
Examples for LCM layout
Type I (ADC=0, COM=1)

Type II (ADC=1, COM=1)

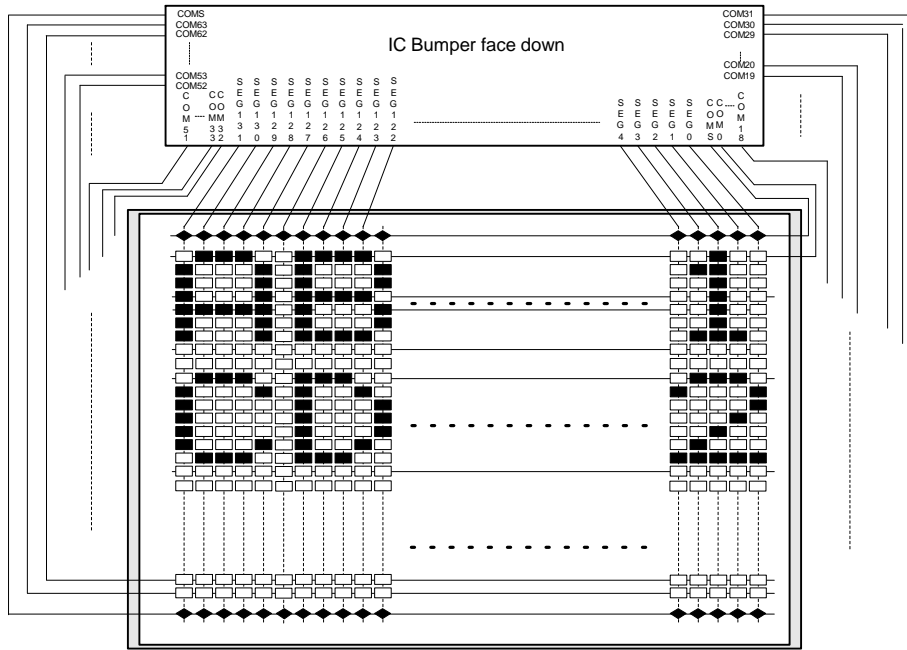
Type III (ADC=1, COM=0)

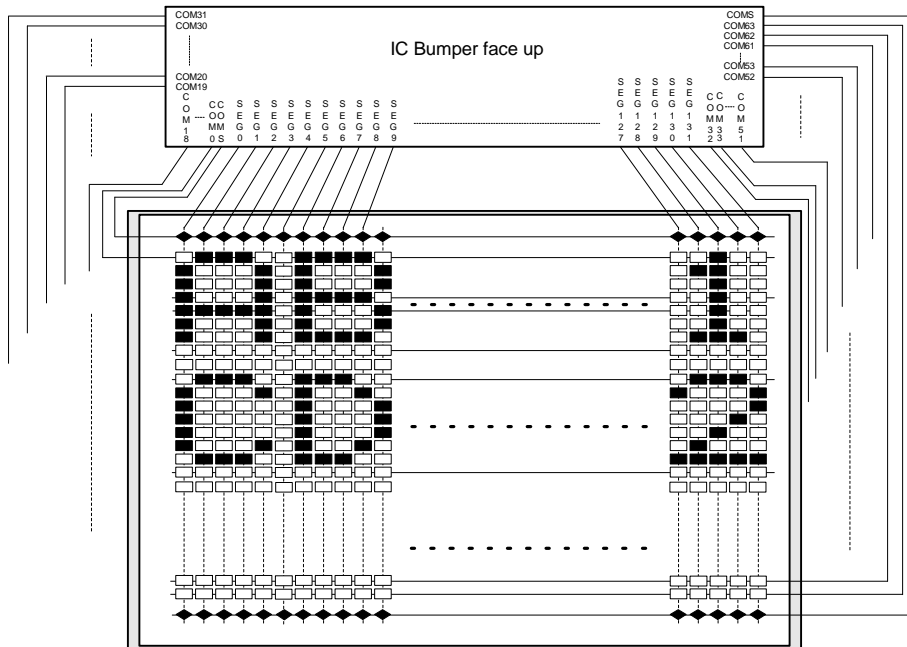

Type IV (ADC=0, COM=0)



Absolute Maximum Rating*

DC Supply Voltage (V_{DD} , V_{DD2})	-0.3V to +3.6V
DC Supply Voltage (V_{OUT})	-0.3V to +14.0V
DC Supply Voltage (V_0)	-0.3V to +13.5V
Input Voltage	-0.3V to $V_{DD} + 0.3V$
Ambient Operating Temperature	-40°C to +85°C
Storage Temperature	-55°C to +125°C

***Comments**

Stresses above those listed under "Absolute Maximum Ratings" may cause permanent damage to this device. These are stress ratings only. Functional operation of this device under these or any other conditions above those indicated in the operational sections of this specification is not implied or intended. Exposure to the absolute maximum rating conditions for extended periods may affect device reliability.

DC Electrical Characteristics

DC Characteristics ($V_{SS} = 0V$, $V_{DD} = 2.4 - 3.5V$, $T_A = -40$ to $85^\circ C$ unless otherwise specified)

Symbol	Parameter	Min.	Typ.	Max.	Unit	Conditions
V_{DD}	Operating Voltage	2.4		3.5	V	
V_{DD2}	Operating Voltage	2.4		3.5	V	
V_{OUT}	Booster output voltage	6.0		12.0	V	
V_0	Voltage regulator operation voltage	4.5		11.5	V	
V_{REG}	Reference voltage	2.04	2.10	2.16	V	$T_A = 25^\circ C$, $-0.05\%/^\circ C$
I_{DD1}	Dynamic current consumption 1	-	21	35	μA	$V_{DD} = 3V$, $V_0 = 11V$, built-in power supply off, display on, display data = checker and no access, $T_A = 25^\circ C$
I_{DD2}	Dynamic current consumption 2	-	96	160	μA	4X boosting, V_{DD} , $V_{DD2} = 3V$, $V_0 = 11V$, built-in power supply on, display on, display data = checker and no access, $T_A = 25^\circ C$, temperature gradient is $-0.05\%/^\circ C$, when V_0 voltage internal resistor is used. Normal mode
I_{DD3}	Dynamic current consumption 3	-	153	255	μA	4X boosting, V_{DD} , $V_{DD2} = 3V$, $V_0 = 11V$, built-in power supply on, display on, display data = checker and no access, $T_A = 25^\circ C$, temperature gradient is $-0.05\%/^\circ C$, when V_0 voltage internal resistor is used. High power mode
I_{SP}	Sleep mode current consumption		0.01	5	μA	During sleep, $T_A = 25^\circ C$
I_{SB}	Standby mode current consumption		4	8	μA	During standby, $T_A = 25^\circ C$
V_{IHC}	High-level input voltage	$0.8V_{DD}$		V_{DD}	V	A0, D0 - D7, /RD(E), /WR(R/W), /CS1, CS2, CLS, CL, FR, M/S, C86, P/S, /DOF, /RES, TMPS, VRS, IRS, and /HPM
V_{ILC}	Low-level input voltage	V_{SS}		$0.2V_{DD}$	V	
V_{OHC}	High-level output voltage	$0.8V_{DD}$		V_{DD}	V	$I_{OH} = -0.5mA$ (D0 - D7, FR, FRS, /DOF, and CL)
V_{OLC}	Low-level output voltage	V_{SS}		$0.2V_{DD}$		$I_{OL} = 0.5mA$ (D0 - D7, FR, FRS, /DOF, and CL)
I_{LI}	Input leakage current	-1.0		1.0	μA	$V_{IN} = V_{DD}$ or V_{SS} (A0, /RD(E), /WR(R/W), /CS1, CS2, CLS, M/S, C86, P/S, IRS, TMPS, VRS and /RES)

DC Characteristics (continued)

I_{HZ}	HZ leakage current	-3.0		3.0	μA	When the D0 - D7, FR, CL, and /DOF are in high impedance	
R_{ON1}	LCD driver ON resistance		2.0	3.5	$K\Omega$	$V_0 = 11.0V$	$T_A = 25^\circ C$, These are the resistance values for when a 0.1V voltage is applied between the output terminals SEGn or COMn and the various power supply terminals (V1, V2, V3, V4).
R_{ON2}	LCD driver ON resistance		3.2	5.4	$K\Omega$	$V_0 = 8.0V$	
C_{IN}	Input pad capacity		5.0	8.0	pF	$T_A = 25^\circ C$, $f = 1MHz$	
f_{OSC}	Oscillation frequency	27	33	39	KHz	$T_A = 25^\circ C$	

Notes: 1. Voltages $V_0 \geq V_1 \geq V_2 \geq V_3 \geq V_4 \geq V_{SS}$ must always be satisfied.

AC Characteristics

System buses Read / Write characteristics 1 (For the 8080 Series MPU)

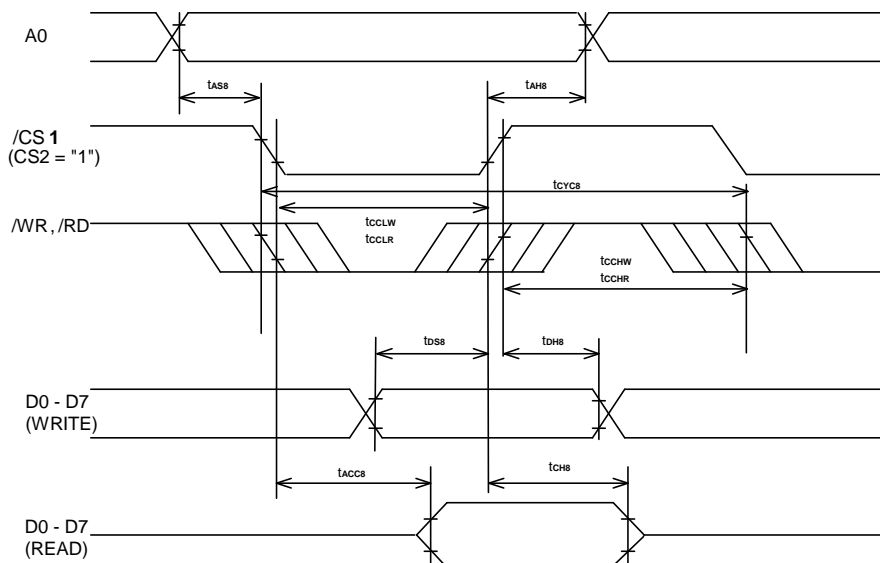

($V_{DD} = 2.4 - 3.5V$, $T_A = -40 - 85^{\circ}C$)

Symbol	Parameter	Min.	Typ.	Max.	Unit	Conditions
tAH8	Address hold time	0			ns	
tAS8	Address setup time	0			ns	
tCYC8	System cycle time	300			ns	
tCCLW	Control L pulse width (/WR)	90			ns	
tCCLR	Control L pulse width (/RD)	120			ns	
tCCHW	Control H pulse width (/WR)	120			ns	
tCCHR	Control H pulse width (/RD)	60			ns	
tDS8	Data setup time	40			ns	
tDH8	Data hold time	15			ns	
tACC8	/RD access time			140	ns	$C_L = 100pF$
tCH8	Output disable time	10		100	ns	$C_L = 100pF$

*1. The input signal rise time and fall time (t_r , t_f) is specified at 15ns or less. When the system cycle time is extremely fast, $(t_r+t_f) \leq (t_{CYC8}-t_{CCLW}-t_{CCHW})$ for $(t_r+t_f) \leq (t_{CYC8}-t_{CCLR}-t_{CCHR})$ are specified.

*2. All timing is specified using 20% and 80% of V_{DD} as the reference.

*3. tCCLW and tCCLR are specified as the overlap between CS1 being "L" (CS2 = "H") and /WR and /RD being at the "L" level.

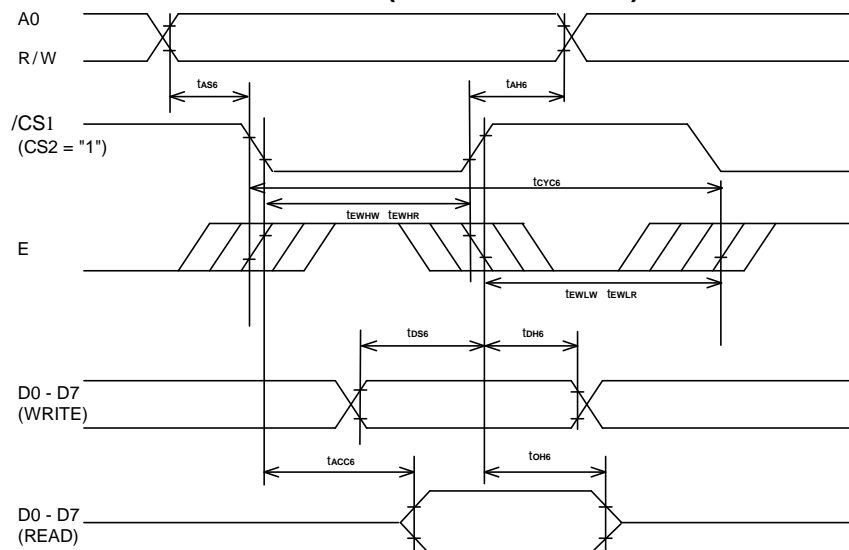
System buses Read/Write Characteristics 2 (6800 Series MPU)

 $(V_{DD} = 2.4 - 3.5V, TA = -40 - 85^{\circ}C)$

Symbol	Parameter	Min.	Typ.	Max.	Unit	Conditions
tCYC6	System cycle time	300			ns	
tAS6	Address setup time	0			ns	
tAH6	Address hold time	0			ns	
tDS6	Data setup time	40			ns	
tDH6	Data hold time	15			ns	
tOH6	Output disable time	10		100	ns	$C_L = 100pF$
tACC6	Access time			140	ns	$C_L = 100pF$
tEWHR	Enable H pulse width (Read)	120			ns	
tEWHW	Enable H pulse width (Write)	90			ns	
tEWLR	Enable L pulse width (Read)	60			ns	
tEWLW	Enable L pulse width (Write)	120			ns	

*1. The input signal rise time and fall time (t_r , t_f) is specified at 15ns or less. When the system cycle time is extremely fast, $(t_r+t_f) \leq (t_{CYC6}-t_{EWLW}-t_{EWHW})$ for $(t_r+t_f) \leq (t_{CYC6}-t_{EWLR}-t_{EWHR})$ are specified.

*2. All timing is specified using 20% and 80% of V_{DD} as the reference.

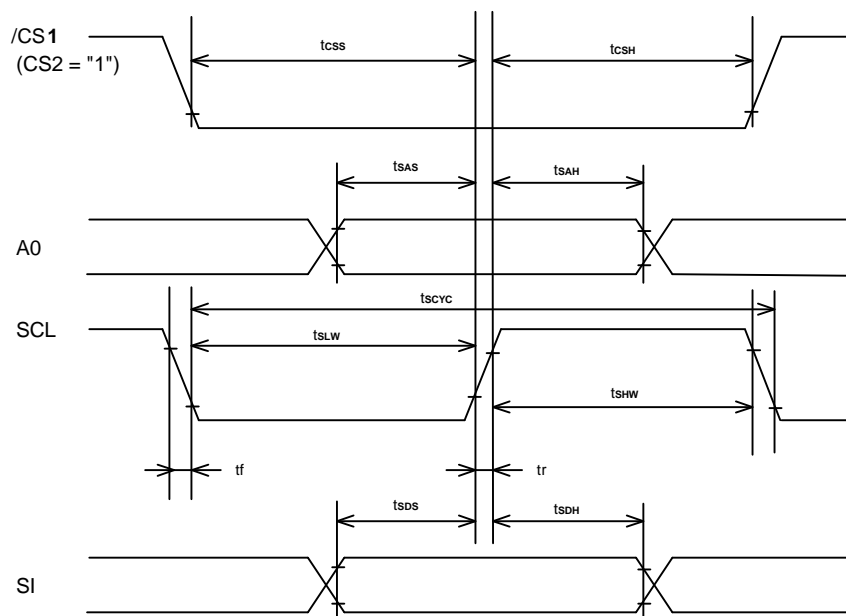
*3. tEWLW and tEWLR are specified as the overlap between /CS1 being "L" ($CS2 = "H"$) and E.

(1)Serial Interface

($V_{DD} = 2.4 - 3.5V$, $T_A = -40 - 85^{\circ}C$)

Symbol	Parameter	Min.	Typ.	Max.	Unit	Conditions
tSCYC	Serial clock cycle	250			ns	
tSHW	Serial clock H pulse width	100			ns	
tSLW	Serial clock L pulse width	100			ns	
tSAS	Address setup time	150			ns	
tSAH	Address hold time	150			ns	
tSDS	Data setup time	100			ns	
tSDH	Data hold time	100			ns	
tCSS	/CS serial clock time	150			ns	
tCSH	/CS serial clock time	150			ns	

*1. The input signal rise time and fall time (t_r , t_f) are specified at 15ns or less

*2. All timing is specified using 20% and 80% of V_{DD} as the standard.

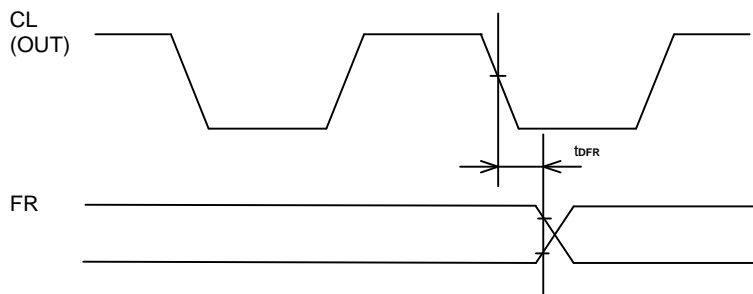
(2) Display Control Timing

($V_{DD} = 2.4 - 3.5V$, $T_A = -40 - 85^{\circ}C$)

Symbol	Parameter	Min.	Typ.	Max.	Unit	Conditions
tDFR	FR delay time		20	80	ns	$C_L = 50pF$

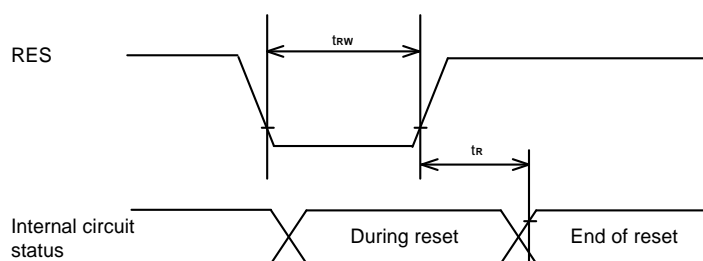
(3) Reset Timing

($V_{DD} = 2.4 - 3.5V$, $T_A = -40 - 85^{\circ}C$)

Symbol	Parameter	Min.	Typ.	Max.	Unit	Conditions
tR	Reset time			1.0	μs	
tRW	Reset low pulse width	1.0			μs	

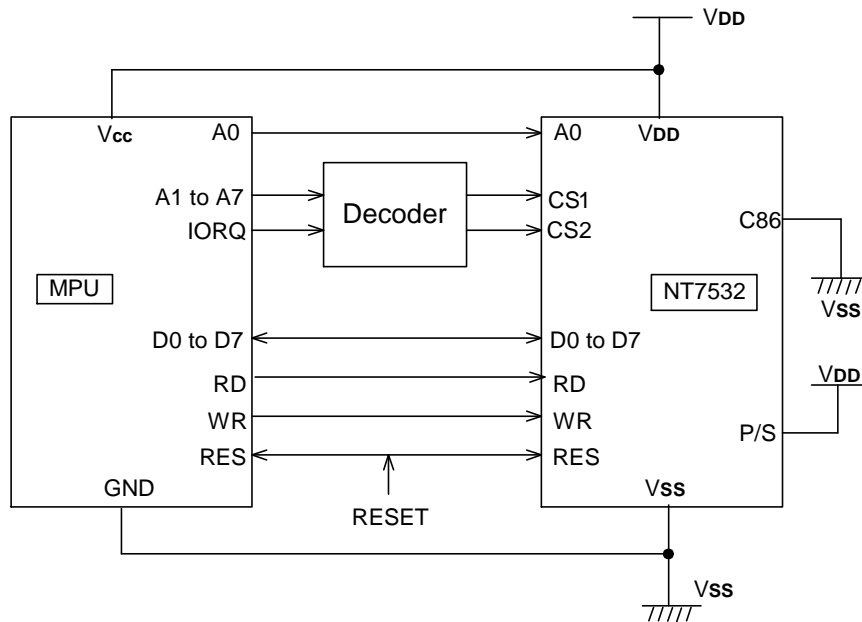
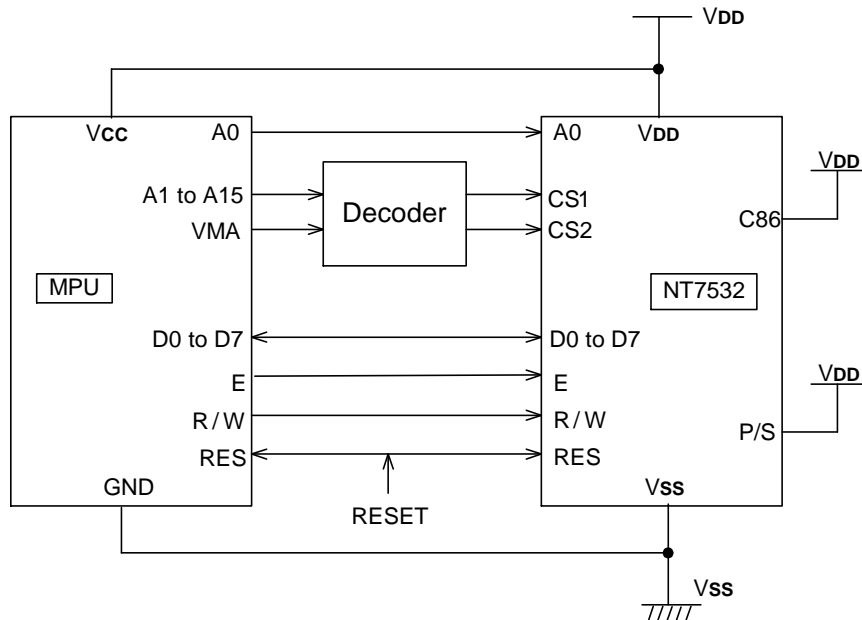
Microprocessor Interface (for reference only)
8080-series microprocessors

Figure. 8
6800-series microprocessors

Figure. 9

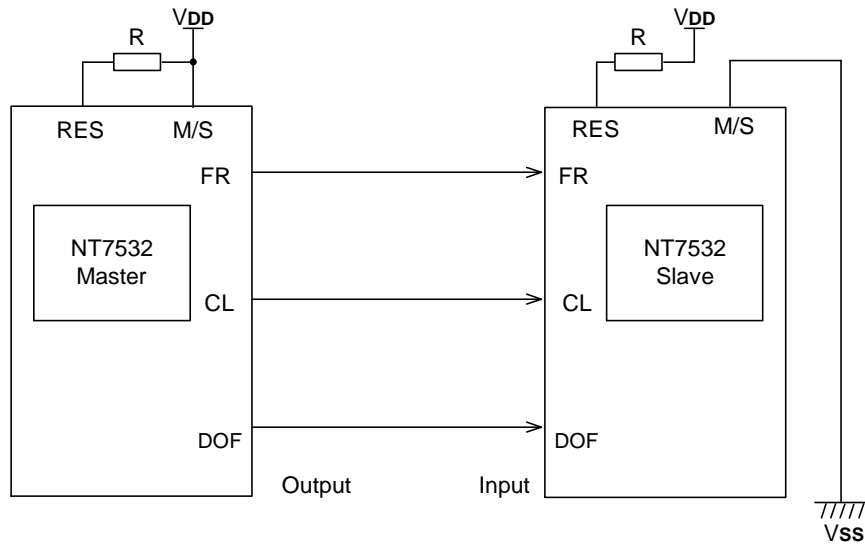
Connections between LCD Drivers (for reference only)

The liquid crystal display area can be enlarged with ease through the use of multiple NT7532 chips. Use the same equipment type.

NT7532 (master) √ NT7532 (slave)

Bonding Diagram

Pad No.	Designation	X	Y	Pad No.	Designation	X	Y
1	NC	-4655.0	-379.0	30	D0	-2625.0	-379.0
2	FRS	-4585.0	-379.0	31	NC	-2555.0	-379.0
3	FR	-4515.0	-379.0	32	D1	-2485.0	-379.0
4	CL	-4445.0	-379.0	33	D1	-2415.0	-379.0
5	/DOF	-4375.0	-379.0	34	NC	-2345.0	-379.0
6	VSS	-4305.0	-379.0	35	D2	-2275.0	-379.0
7	/CS1	-4235.0	-379.0	36	D2	-2205.0	-379.0
8	/CS1	-4165.0	-379.0	37	NC	-2135.0	-379.0
9	/CS1	-4095.0	-379.0	38	D3	-2065.0	-379.0
10	CS2	-4025.0	-379.0	39	D3	-1995.0	-379.0
11	CS2	-3955.0	-379.0	40	NC	-1925.0	-379.0
12	CS2	-3885.0	-379.0	41	D4	-1855.0	-379.0
13	VDD	-3815.0	-379.0	42	D4	-1785.0	-379.0
14	/RES	-3745.0	-379.0	43	NC	-1715.0	-379.0
15	/RES	-3675.0	-379.0	44	D5	-1645.0	-379.0
16	/RES	-3605.0	-379.0	45	D5	-1575.0	-379.0
17	A0	-3535.0	-379.0	46	NC	-1505.0	-379.0
18	A0	-3465.0	-379.0	47	D6	-1435.0	-379.0
19	A0	-3395.0	-379.0	48	D6	-1365.0	-379.0
20	VSS	-3325.0	-379.0	49	NC	-1295.0	-379.0
21	/WR	-3255.0	-379.0	50	D7	-1225.0	-379.0
22	/WR	-3185.0	-379.0	51	D7	-1155.0	-379.0
23	/WR	-3115.0	-379.0	52	NC	-1085.0	-379.0
24	/RD	-3045.0	-379.0	53	NC	-1015.0	-379.0
25	/RD	-2975.0	-379.0	54	NC	-945.0	-379.0
26	/RD	-2905.0	-379.0	55	NC	-875.0	-379.0
27	VDD	-2835.0	-379.0	56	VDD	-805.0	-379.0
28	TEST0	-2765.0	-379.0	57	DUTY0	-735.0	-379.0
29	D0	-2695.0	-379.0	58	VSS	-665.0	-379.0

Bonding Diagram (Continued)

Pad No.	Designation	X	Y	Pad No.	Designation	X	Y
59	DUTY1	-595.0	-379.0	93	CAP2+	1785.0	-379.0
60	VDD	-525.0	-379.0	94	CAP2+	1855.0	-379.0
61	VDD	-455.0	-379.0	95	CAP2-	1925.0	-379.0
62	VDD	-385.0	-379.0	96	CAP2-	1995.0	-379.0
63	VDD	-315.0	-379.0	97	CAP2-	2065.0	-379.0
64	VDD2	-245.0	-379.0	98	CAP2-	2135.0	-379.0
65	VDD2	-175.0	-379.0	99	VSS	2205.0	-379.0
66	VDD2	-105.0	-379.0	100	VEXT	2275.0	-379.0
67	VDD2	-35.0	-379.0	101	VRS	2345.0	-379.0
68	VSS	35.0	-379.0	102	VDD	2415.0	-379.0
69	VSS	105.0	-379.0	103	V1	2485.0	-379.0
70	VSS	175.0	-379.0	104	V1	2555.0	-379.0
71	VSS	245.0	-379.0	105	V1	2625.0	-379.0
72	VSS2	315.0	-379.0	106	V2	2695.0	-379.0
73	VSS2	385.0	-379.0	107	V2	2765.0	-379.0
74	VSS2	455.0	-379.0	108	V2	2835.0	-379.0
75	VSS2	525.0	-379.0	109	V3	2905.0	-379.0
76	VOUT	595.0	-379.0	110	V3	2975.0	-379.0
77	VOUT	665.0	-379.0	111	V3	3045.0	-379.0
78	VOUT	735.0	-379.0	112	V4	3115.0	-379.0
79	CAP3+	805.0	-379.0	113	V4	3185.0	-379.0
80	CAP3+	875.0	-379.0	114	V4	3255.0	-379.0
81	CAP3+	945.0	-379.0	115	V0	3325.0	-379.0
82	CAP3+	1015.0	-379.0	116	V0	3395.0	-379.0
83	CAP1-	1085.0	-379.0	117	V0	3465.0	-379.0
84	CAP1-	1155.0	-379.0	118	VR	3535.0	-379.0
85	CAP1-	1225.0	-379.0	119	VR	3605.0	-379.0
86	CAP1-	1295.0	-379.0	120	VSS	3675.0	-379.0
87	CAP1+	1365.0	-379.0	121	VSS	3745.0	-379.0
88	CAP1+	1435.0	-379.0	122	VDD	3815.0	-379.0
89	CAP1+	1505.0	-379.0	123	M/S	3885.0	-379.0
90	CAP1+	1575.0	-379.0	124	CLS	3955.0	-379.0
91	CAP2+	1645.0	-379.0	125	VSS	4025.0	-379.0
92	CAP2+	1715.0	-379.0	126	C86	4095.0	-379.0

Bonding Diagram (Continued)

Pad No.	Designation	X	Y	Pad No.	Designation	X	Y
127	PS	4165.0	-379.0	163	COM3	3877.5	379.0
128	VDD	4235.0	-379.0	164	COM2	3822.5	379.0
129	/HPM	4305.0	-379.0	165	COM1	3767.5	379.0
130	VSS	4375.0	-379.0	166	COM0	3712.5	379.0
131	IRS	4445.0	-379.0	167	COMS	3657.5	379.0
132	VDD	4515.0	-379.0	168	SEG0	3602.5	379.0
133	NC	4585.0	-379.0	169	SEG1	3547.5	379.0
134	VSS	4655.0	-379.0	170	SEG2	3492.5	379.0
135	COM31	5059.0	-330.0	171	SEG3	3437.5	379.0
136	COM30	5059.0	-275.0	172	SEG4	3382.5	379.0
137	COM29	5059.0	-220.0	173	SEG5	3327.5	379.0
138	COM28	5059.0	-165.0	174	SEG6	3272.5	379.0
139	COM27	5059.0	-110.0	175	SEG7	3217.5	379.0
140	COM26	5059.0	-55.0	176	SEG8	3162.5	379.0
141	COM25	5059.0	0.0	177	SEG9	3107.5	379.0
142	COM24	5059.0	55.0	178	SEG10	3052.5	379.0
143	COM23	5059.0	110.0	179	SEG11	2997.5	379.0
144	COM22	5059.0	165.0	180	SEG12	2942.5	379.0
145	COM21	5059.0	220.0	181	SEG13	2887.5	379.0
146	COM20	5059.0	275.0	182	SEG14	2832.5	379.0
147	COM19	5059.0	330.0	183	SEG15	2777.5	379.0
148	COM18	4702.5	379.0	184	SEG16	2722.5	379.0
149	COM17	4647.5	379.0	185	SEG17	2667.5	379.0
150	COM16	4592.5	379.0	186	SEG18	2612.5	379.0
151	COM15	4537.5	379.0	187	SEG19	2557.5	379.0
152	COM14	4482.5	379.0	188	SEG20	2502.5	379.0
153	COM13	4427.5	379.0	189	SEG21	2447.5	379.0
154	COM12	4372.5	379.0	190	SEG22	2392.5	379.0
155	COM11	4317.5	379.0	191	SEG23	2337.5	379.0
156	COM10	4262.5	379.0	192	SEG24	2282.5	379.0
157	COM9	4207.5	379.0	193	SEG25	2227.5	379.0
158	COM8	4152.5	379.0	194	SEG26	2172.5	379.0
159	COM7	4097.5	379.0	195	SEG27	2117.5	379.0
160	COM6	4042.5	379.0	196	SEG28	2062.5	379.0
161	COM5	3987.5	379.0	197	SEG29	2007.5	379.0
162	COM4	3932.5	379.0	198	SEG30	1952.5	379.0

Bonding Diagram (Continued)

Pad No.	Designation	X	Y	Pad No.	Designation	X	Y
199	SEG31	1897.5	379.0	235	SEG67	-82.5	379.0
200	SEG32	1842.5	379.0	236	SEG68	-137.5	379.0
201	SEG33	1787.5	379.0	237	SEG69	-192.5	379.0
202	SEG34	1732.5	379.0	238	SEG70	-247.5	379.0
203	SEG35	1677.5	379.0	239	SEG71	-302.5	379.0
204	SEG36	1622.5	379.0	240	SEG72	-357.5	379.0
205	SEG37	1567.5	379.0	241	SEG73	-412.5	379.0
206	SEG38	1512.5	379.0	242	SEG74	-467.5	379.0
207	SEG39	1457.5	379.0	243	SEG75	-522.5	379.0
208	SEG40	1402.5	379.0	244	SEG76	-577.5	379.0
209	SEG41	1347.5	379.0	245	SEG77	-632.5	379.0
210	SEG42	1292.5	379.0	246	SEG78	-687.5	379.0
211	SEG43	1237.5	379.0	247	SEG79	-742.5	379.0
212	SEG44	1182.5	379.0	248	SEG80	-797.5	379.0
213	SEG45	1127.5	379.0	249	SEG81	-852.5	379.0
214	SEG46	1072.5	379.0	250	SEG82	-907.5	379.0
215	SEG47	1017.5	379.0	251	SEG83	-962.5	379.0
216	SEG48	962.5	379.0	252	SEG84	-1017.5	379.0
217	SEG49	907.5	379.0	253	SEG85	-1072.5	379.0
218	SEG50	852.5	379.0	254	SEG86	-1127.5	379.0
219	SEG51	797.5	379.0	255	SEG87	-1182.5	379.0
220	SEG52	742.5	379.0	256	SEG88	-1237.5	379.0
221	SEG53	687.5	379.0	257	SEG89	-1292.5	379.0
222	SEG54	632.5	379.0	258	SEG90	-1347.5	379.0
223	SEG55	577.5	379.0	259	SEG91	-1402.5	379.0
224	SEG56	522.5	379.0	260	SEG92	-1457.5	379.0
225	SEG57	467.5	379.0	261	SEG93	-1512.5	379.0
226	SEG58	412.5	379.0	262	SEG94	-1567.5	379.0
227	SEG59	357.5	379.0	263	SEG95	-1622.5	379.0
228	SEG60	302.5	379.0	264	SEG96	-1677.5	379.0
229	SEG61	247.5	379.0	265	SEG97	-1732.5	379.0
230	SEG62	192.5	379.0	266	SEG98	-1787.5	379.0
231	SEG63	137.5	379.0	267	SEG99	-1842.5	379.0
232	SEG64	82.5	379.0	268	SEG100	-1897.5	379.0
233	SEG65	27.5	379.0	269	SEG101	-1952.5	379.0
234	SEG66	-27.5	379.0	270	SEG102	-2007.5	379.0

Bonding Diagram (Continued)

Pad No.	Designation	X	Y	Pad No.	Designation	X	Y
271	SEG103	-2062.5	379.0	302	COM34	-3767.5	379.0
272	SEG104	-2117.5	379.0	303	COM35	-3822.5	379.0
273	SEG105	-2172.5	379.0	304	COM36	-3877.5	379.0
274	SEG106	-2227.5	379.0	305	COM37	-3932.5	379.0
275	SEG107	-2282.5	379.0	306	COM38	-3987.5	379.0
276	SEG108	-2337.5	379.0	307	COM39	-4042.5	379.0
277	SEG109	-2392.5	379.0	308	COM40	-4097.5	379.0
278	SEG110	-2447.5	379.0	309	COM41	-4152.5	379.0
279	SEG111	-2502.5	379.0	310	COM42	-4207.5	379.0
280	SEG112	-2557.5	379.0	311	COM43	-4262.5	379.0
281	SEG113	-2612.5	379.0	312	COM44	-4317.5	379.0
282	SEG114	-2667.5	379.0	313	COM45	-4372.5	379.0
283	SEG115	-2722.5	379.0	314	COM46	-4427.5	379.0
284	SEG116	-2777.5	379.0	315	COM47	-4482.5	379.0
285	SEG117	-2832.5	379.0	316	COM48	-4537.5	379.0
286	SEG118	-2887.5	379.0	317	COM49	-4592.5	379.0
287	SEG119	-2942.5	379.0	318	COM50	-4647.5	379.0
288	SEG120	-2997.5	379.0	319	COM51	-4702.5	379.0
289	SEG121	-3052.5	379.0	320	COM52	-5059.0	330.0
290	SEG122	-3107.5	379.0	321	COM53	-5059.0	275.0
291	SEG123	-3162.5	379.0	322	COM54	-5059.0	220.0
292	SEG124	-3217.5	379.0	323	COM55	-5059.0	165.0
293	SEG125	-3272.5	379.0	324	COM56	-5059.0	110.0
294	SEG126	-3327.5	379.0	325	COM57	-5059.0	55.0
295	SEG127	-3382.5	379.0	326	COM58	-5059.0	0
296	SEG128	-3437.5	379.0	327	COM59	-5059.0	-55.0
297	SEG129	-3492.5	379.0	328	COM60	-5059.0	-110.0
298	SEG130	-3547.5	379.0	329	COM61	-5059.0	-165.0
299	SEG131	-3602.5	379.0	330	COM62	-5059.0	-220.0
300	COM32	-3657.5	379.0	331	COM63	-5059.0	-275.0
301	COM33	-3712.5	379.0	332	COMS	-5059.0	-330.0

Dummy Pad Location (Total: 8 pins)

NO	X	Y	NO	X	Y	NO	X	Y
0	-4745.0	-379.0	3	5059.0	390.0	6	-5059.0	390.0
1	4745.0	-379.0	4	4762.5	379.0	7	-5059.0	-390.0
2	5059.0	-390.0	5	-4762.5	379.0			

Alignment Mark Location (Total: 2 pins)

NO	X	Y
L	-4581.0	-143.0
R	4581.0	-143.0

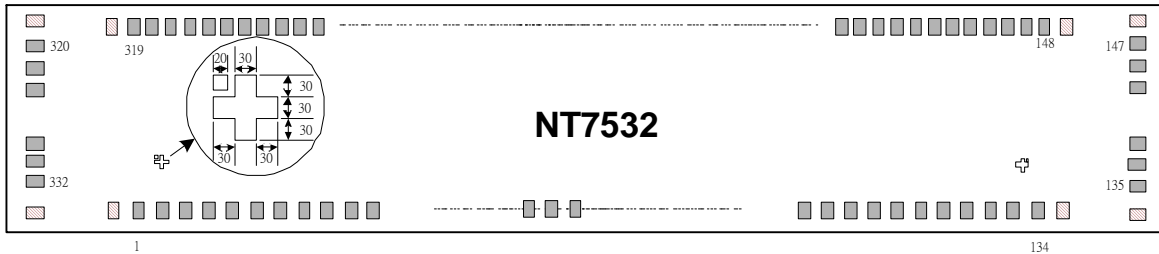
Package Information

Chip Outline Dimensions

Item	Pad No.	Size		Unit
		X	Y	
Chip size	-	10390	1038	µm
Bump size	1 ~ 134	42	90	µm
	135 ~ 147, 320 ~ 332	90	35	
	148 ~ 319	35	90	
	Dummy 0, 1, 4, 5	45	90	
	Dummy 2, 3, 6, 7	90	45	
Pad pitch	1 ~ 134	70		µm
	135 ~ 332	55		µm
	Dummy 0 ~ 1	90		µm
	134 ~ Dummy 1	60		
	Dummy 2 ~ 135			
	147 ~ Dummy 3			
	Dummy 4 ~ 148			
	319 ~ Dummy 5			
	Dummy 6 ~ 320			
332 ~ Dummy 7				
Bump height	all pads	15 ± 3		µm

Ordering Information

Part No.	Packages
NT7532H-BDT	Gold Bump on Chip Tray
NT7532H-TABF1	Tape Automated Bonding Package

Cautions

1. The contents of this document are subject to change without notice.
2. Precautions against light projection:

Light has the effect of causing the electrons of semiconductor to move; so light projection may change the characteristics of semiconductor devices. For this reason, it is necessary to take account of effective protection measures for the packages (such as COB, COG, TCP and COF, etc.) causing chip to be exposed to a light environment in order to isolate the projection of light on any part of the chip, including top, bottom and the area around the chip.

Observe the following instructions in using this product:

 - a. During the design stage, it is necessary to notice and confirm the light sensitivity and preventive measures for using IC on substrate (PCB, Glass or Film) or product.
 - b. Test and inspect the product under an environment free of light source penetration.
 - c. Confirm that all surfaces around the IC will not be exposed to a light source.