

NTC Power Thermistor

NSE SENSOR CO., LTD

Ma-2124,15, Gyeongin-ro 53-gil, Guro-gu, Seoul, Republic of Korea

TEL : 82-2-6679-8195 FAX : 82-2-6679-8196

Email: nse@nse-sensor.com

NTC POWER THERMISTOR

NTC POWER THERMISTOR

Application

Temperature measurement and control of household and automobile air-condition, refrigeratory, icebox, water heater, drinking trough, radiator, dishwasher, disinfector, washing machine, drying machine, middle-or-low-temperature drying box and constant temperature box.

Characteristics

Adopting new technique, Steady product performance, Capability of long time operating

- High precision of resistance and B value, Good coherence, Interchange capable
- Fast response, High delicacy
- Good quality of insulation and package, High capability of colliding and bending resistance and High

Type	NTC Power Thermistor
Function	Good quality of coherence and interchange
Application	Air-Conditioner Equipments, Electric table-board, Battery
Working Temperature Range	-40 ~ +105℃ / +125℃
Rated Resistance (R25)	0.1 ~ 1000K (KΩ)
B value(25/50℃)	3100 ~ 4550 (K)

Caution

- You should consider the temperature of your environment. If not careful, the epoxy may melt or cause distortion in the wires.
- In basic design, reference should be made to the RT table of the data.
- This product is for temperature detection only.

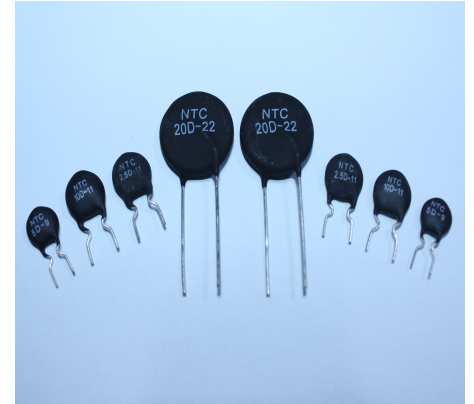

<NTC POWER THERMISTOR>

Advantage

- Fast Response
- Reliable temperature detection
- Available in a wide variety of shapes and colors

Customer Check Point

- Is the temperature sensor suitable for use?
- Is waterproof function used in an environment?
- Do you need a connector at the end of the wire?

NSE-SENSOR Co.,
Ltd 20180517 Write
+82-2-6679-8195
nse@nse-sensor.com
www.nse-sensor.com



NTC POWER THERMISTOR

Part Numbering Form

1	2	3	4	5	6	7	8
NTC	22	D	9	M	IF	050	P
1	Product Type			NTC POWER THERMISTOR			
2	Zero Power Resistance(R25)			0.7 ~ 400Ω			
3	Shape			DISK			
4	Diameter of Element			7φ / 9φ / 11φ / 13φ / 15φ / 22φ / 25φ			
5	The tolerance of Resistance			M (±20%)			
6	Lead Type			S = Straight / O = Out Forming / IF = In Forming			
7	Lead Length			040 = 4mm / 050 = 5mm / 250 = 25mm			
8	Type Of Coating			S = Silicon Coating / P = Phernols Coating			

Dimmension

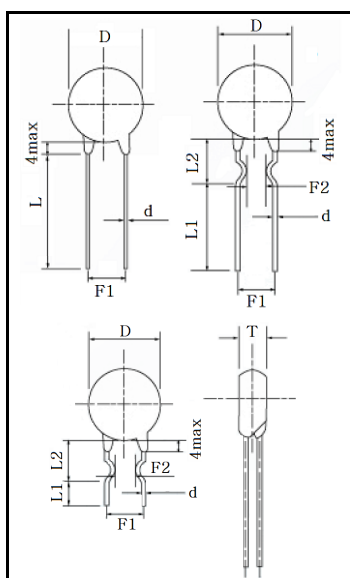

Sym	Dim(mm)	Dmax	T max	d ± 0.05	F1 ± 1	F2 ± 1.5	Straight lead	Curved lead	
								Lmin	L1min
Part No									
NTC □D5		7.0	5	0.6/0.45	5/2.5	3	25	17.5	8/5
NTC □D7		9.0	5	0.6	5.0	3	25	17.5	8/5
NTC □D9		11.0	5.5	0.8/0.6	7.5/5	5/3	25	17.5	8/5
NTC □D11		13.0	5.5	0.8	7.5/5	5/3	25	17.5	8/5
NTC □D13		15.5	6	0.8	7.5	5	25	17.5	8/5
NTC □D15		17.5	6	0.8	10/7.5	5	25	17.5	8/5
NTC □D22		22.5	7	1.0	10/7.5	/	25	/	/
NTC □D25		27.5	8	1.0	10/7.5	/	25	/	/

Caution

- In order to use the product, there must be information about the resistance - In basic design, reference should be made to the RT table of the data.
- This product is dedicated to the inrush current limit.

NSE-SENSOR Co.,
 Ltd 20180517 Write
 +82-2-6679-8195
 nse@nse-sensor.com
 www.nse-sensor.com



NTC POWER THERMISTOR

MAIN THECHNO-PARAMETER

Part No.	R25 (Ω)	Max. Steady State Current (A)	Approx. R of Max . Cur (Ω)	Dissi Coef (Mw/ $^{\circ}$ C)	Thermal Time Constant(S)	Operating Temp. ($^{\circ}$ C)
5D5	5	1	0.353	15	17	-40 ~ +150'C
10D5	10	0.7	0.771			
60D5	60	0.3	1.878			
200D5	200	0.1	18.7			
5D7	5	2	0.283	16	27	
8D7	8	1	0.539			
10D7	10	1	0.616			
12D7	12	1	0.816			
16D7	16	0.7	1.003			
22D7	22	0.6	1.108			
33D7	33	0.5	1.485			
200D7	200	0.2	11.65			
3D9	3	4	0.120	16	38	-40 ~ +170'C
4D9	4	3	0.190			
5D9	5	3	0.210			
6D9	6	2	0.315			
8D9	8	2	0.400			
10D9	10	2	0.458			
12D9	12	1	0.652			
16D9	16	1	0.802			
20D9	20	1	0.864			

Caution

- In order to use the product, there must be information about the resistance -
- In basic design, reference should be made to the RT table of the data.
- This product is dedicated to the inrush current limit.

NSE-SENSOR Co.,
Ltd 20180517 Write
+82-2-6679-8195
nse@nse-sensor.com
www.nse-sensor.com



NTC POWER THERMISTOR

MAIN THECHNO-PARAMETER

Part No.	R25 (Ω)	Max. Steady State Current (A)	Approx. R of Max . Cur (Ω)	Dissi Coef (Mw/ $^{\circ}$ C)	Thermal Time Constant(S)	Operating Temp. ($^{\circ}$ C)
22D9	22	1	0.950	16	38	-40 ~ +170'C
30D9	30	1	1.022			
33D9	33	1	1.124			
50D9	50	1	1.252			
60D9	60	0.8	1.502			
80D9	80	0.8	2.010			
120D9	120	0.8	3.015			
200D9	200	0.5	5.007			
400D9	400	0.2	30.30			
2.5D11	2.5	5	0.095			
3D11	3	5	0.100			
4D11	4	4	0.150			
5D11	5	4	0.156			
6D11	6	3	0.24			
8D11	8	3	0.255			
10D11	10	4	0.275			
12D11	12	2	0.462			
16D11	16	2	0.470			
20D11	20	2	0.512			
22D11	22	2	0.563			
30D11	30	1.5	0.667			

Caution

- In order to use the product, there must be information about the resistance - In basic design, reference should be made to the RT table of the data.
- This product is dedicated to the inrush current **limit**.

NSE-SENSOR Co.,
Ltd 20180517 Write
+82-2-6679-8195
nse@nse-sensor.com
www.nse-sensor.com



NTC POWER THERMISTOR

MAIN THECHNO-PARAMETER

Part No.	R25 (Ω)	Max. Steady State Current (A)	Approx. R of Max . Cur (Ω)	Dissi Coef (Mw/°C)	Thermal Time Constant(S)	Operating Temp. (°C)
33D11	33	1.5	0.734	17	43	-40 ~ +170°C
50D11	50	1.5	1.021			
60D11	60	1.5	1.215			
80D11	80	1.2	1.656			
1.3D13	1.3	7	0.062	18	66	-40 ~ +200°C
1.5D13	1.5	7	0.073			
2.5D13	2.5	6	0.088			
3D13	3	6	0.092			
4D13	4	5	0.120			
5D13	5	5	0.125			
6D13	6	4	0.170			
7D13	7	4	0.188			
8D13	8	4	0.194			
10D13	10	43	0.206			
12D13	12	3	0.316			
15D13	15	3	0.335			
16D13	16	3	0.338			
20D13	20	3	0.372			
30D13	30	2.5	0.517			
47D13	47	2	0.810			
120D13	120	1.5	2.124			

Caution

- In order to use the product, there must be information about the resistance -
In basic design, reference should be made to the RT table of the data.
- This product is dedicated to the inrush current **limit**.

NSE-SENSOR Co.,
Ltd 20180517 Write
+82-2-6679-8195
nse@nse-sensor.com
www.nse-sensor.com



NTC POWER THERMISTOR

MAIN THECHNO-PARAMETER

Part No.	R25 (Ω)	Max. Steady State Current (A)	Approx. R of Max . Cur (Ω)	Dissi Coef (Mw/ $^{\circ}$ C)	Thermal Time Constant(S)	Operating Temp. ($^{\circ}$ C)
1.3D15	1.3	8	0.048	21	75	-40 ~ +200'C
1.5D15	1.5	8	0.052			
2.5D15	2.5	7	0.065			
3D15	3	7	0.075			
5D15	5	6	0.112			
6D15	6	5	0.155			
7D15	7	5	0.173			
8D15	8	5	0.178			
10D15	10	5	0.180			
12D15	12	4	0.250			
15D15	15	4	0.268			
16D15	16	2	0.276			
20D15	20	2	0.288			
30D15	30	2	0.438			
47D15	47	2	0.680			
120D15	120	1.5	1.652			
0.7D22	0.7	1.5	0.018	28	113	-40 ~ +200'C
1.3D22	1.3	1.5	0.037			
3D22	3	1.5	0.055			
5D22	5	1.2	0.087			
6D22	6	7	0.113			

Caution

- In order to use the product, there must be information about the resistance -
In basic design, reference should be made to the RT table of the data.
- This product is dedicated to the inrush current **limit**.

NSE-SENSOR Co.,
Ltd 20180517 Write
+82-2-6679-8195
nse@nse-sensor.com
www.nse-sensor.com



NTC POWER THERMISTOR

MAIN THECHNO-PARAMETER

Part No.	R25 (Ω)	Max. Steady State Current (A)	Approx. R of Max . Cur (Ω)	Dissi Coef (Mw/ $^{\circ}$ C)	Thermal Time Constant(S)	Operating Temp. ($^{\circ}$ C)
8D22	8	6	0.142	30	130	-40 ~ +200'C
10D22	10	6	0.162			
12D22	12	5	0.195			
16D22	16	5	0.212			
0.7D25	0.7	12	0.014			
1.5D25	1.5	10	0.027			
3D25	2.5	9	0.044			
5D25	5	8	0.070			
8D25	8	7	0.114			
10D25	10	7	0.130			
12D25	12	6	0.156			
16D25	16	6	0.160			

Caution

- In order to use the product, there must be information about the resistance -
In basic design, reference should be made to the RT table of the data.
- This product is dedicated to the inrush current **limit**.

NSE-SENSOR Co.,
Ltd 20180517 Write
+82-2-6679-8195
nse@nse-sensor.com
www.nse-sensor.com

