



ELECTRONICS, INC.
 44 FARRAND STREET
 BLOOMFIELD, NJ 07003
 (973) 748-5089

NTE1854D/NTE1854M Integrated Circuit Dual Power Operational Amplifier

Description:

The NTE1854D/NTE1854M is a monolithic dual-power operational amplifier which features a high current, low saturation voltage, flyback protected output stage optimized for driving heavy inductive loads. Capable of operation in a single supply mode form as low as 4.5V up to 13.2V, the NTE1854D/NTE1854M is ideally suited for the computer peripheral environment, driving small motors, solenoids, and linear actuators in an H-bridge configuration.

As a general-purpose op amp, the NTE1854D/NTE1854M exhibits low input offset voltage, high open loop gain, low quiescent current, a large differential input voltage range, and a common-mode input voltage range which includes ground (V_{EE}).

Features:

- Full output swing at $\pm 500\text{mA}$
- High inductive load drive capability
- Internal flyback protection diodes
- Low power dissipation
- Single or split supply operation
- Common-mode range includes ground (V_{EE})
- High open loop gain
- Low input offset voltage
- Large differential input voltage range
- Thermal shutdown protection
- Available in Two Package Types:
 NTE1854M: 8-Lead Mini DIP
 NTE1854D: 14-Lead DIP

Absolute Maximum Ratings: (Note 1)

Supply Voltage (Single Supply), V_{CC}	-0.3V to 14V
DC Output Current, I_{OUT}	$\pm 1.0\text{A}$
Peak Output Current (Non-Repetitive), I_{OUT}	$\pm 1.5\text{A}$
Common-Mode Input Voltage, V_{ICM}	-0.3V to $V_{CC} - 2\text{V}$
Differential-Mode Input Voltage, V_{IDM}	$\pm V_{CC}$
Operational Junction Temperature, T_J	+150°C
Storage Temperature Range, T_{stg}	-65°C to 150°C
Lead Temperature (During Soldering, 10sec), T_L	+300°C

Note 1 Exceeding these ratings could cause damage to the device. All voltages are with respect to GND. All currents are positive into the specified terminal.

Recommended Operating Conditions:

Supply Voltage (Single Supply), V_{CC} 4.5V to 13.2V
 DC Output Current, I_{OUT} $\pm 500\text{mA}$
 Common-mode Input Voltage, V_{ICM} 0V to $V_{CC} - 2\text{V}$
 Differential-Mode Input Voltage, V_{IDM} $\pm V_{CC}$
 Operating Ambient Temperature Range, T_A 0°C to 70°C

Electrical Specifications: ($V_{CC} = 12\text{V}$, $T_A = 25^\circ\text{C}$, unless otherwise specified.)

Parameter	Symbol	Test Conditions	Min	Typ	Max	Unit
STATIC CHARACTERISTICS						
Input Offset Voltage	V_{IO}		-15	0	+15	mV
		$T_A = T_{MIN}$ to T_{MAX}	-30	-	+30	mV
Input Bias Current	I_B		-1.0	-0.2	-	μA
Input Offset Current	I_{OS}		-50	-	+50	nA
		$T_A = T_{MIN}$ to T_{MAX}	-200	-	+200	nA
Difference Input Resistance	R_{ID}		500	-	-	$\text{K}\Omega$
Source Side Output Saturation Voltage	$(+)V_{SAT}$	$I_{OUT} = -100\text{mA}$	-	0.8	-	V
		$I_{OUT} = -500\text{mA}$	-	1.0	1.5	V
Sink Side Output Saturation Voltage	$(-)V_{SAT}$	$I_{OUT} = -100\text{mA}$	-	0.3	-	V
		$I_{OUT} = -500\text{mA}$	-	0.6	1.0	V
Open Loop Voltage Gain	A_{VOL}		70	90	-	dB
Common-Mode Rejection Ratio	CMRR		66	90	-	dB
Power Supply Rejection Ratio	PSRR		60	80	-	dB
Quiescent Drain Current	I_{CC}		-	7	15	mA
Thermal Shutdown Temperature			-	175	-	$^\circ\text{C}$
DYNAMIC CHARACTERISTICS						
Gain Bandwidth Product	GBWP	$R_L = \infty\Omega$	-	800	-	kHz
Slew Rate	dV_O/dt	$AV = 1$	-	1.6	-	$\text{V}/\mu\text{s}$
Power Bandwidth, -3dB	PBW		-	200	-	kHz
Input Noise Voltage	E_N	22Hz to 22kHz	-	10	-	μV
Input Noise Current	I_N	22Hz to 22kHz	-	200	-	pA
Channel Separation	C_S	$f = 1\text{kHz}$, $R_L = 10\Omega$, $AV_{CL} = 30\text{dB}$	-	60	-	dB

Pin Connection Diagram
NTE1854D

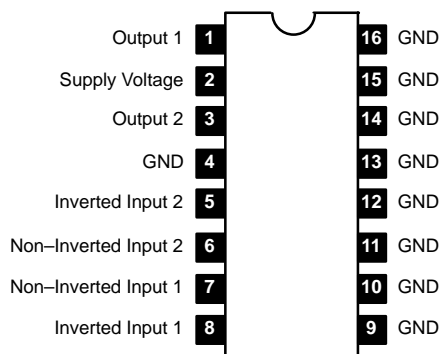

Pin Connection Diagram
NTE1854M

