



ELECTRONICS, INC.
 44 FARRAND STREET
 BLOOMFIELD, NJ 07003
 (973) 748-5089
<http://www.nteinc.com>

NTE7408 Integrated Circuit TTL – Quad 2–Input Positive AND Gate

Description:

The NTE7408 contains four independent 2–Input AND gates in a 14–Lead plastic DIP type package.

Absolute Maximum Ratings: (Note 1)

Supply Voltage, V_{CC} 7V
 DC Input Voltage, V_{IN} 5.5V
 Operating Temperature Range, T_A 0°C to +70°C
 Storage Temperature Range, T_{stg} –65°C to +150°C

Note 1. Unless otherwise specified, all voltages are referenced to GND.

Recommended Operating Conditions:

Parameter	Symbol	Min	Typ	Max	Unit
Supply Voltage	V_{CC}	4.75	5.0	5.25	V
High–Level Input Voltage	V_{IH}	2.0	–	–	V
Low–Level Input Voltage	V_{IL}	–	–	0.8	V
High–Level Output Current	I_{OH}	–	–	–0.8	mA
Low–Level Output Current	I_{OL}	–	–	16	mA
Operating Temperature Range	T_A	0	–	+70	°C

Electrical Characteristics: (Note 2, Note 3)

Parameter	Symbol	Test Conditions	Min	Typ	Max	Unit
Input Clamp Voltage	V_{IK}	$V_{CC} = \text{MIN}, I_I = -12\text{mA}$	–	–	–1.5	V
High Level Output Voltage	V_{OH}	$V_{CC} = \text{MIN}, V_{IH} = 2\text{V}, I_{OH} = -0.8\text{mA}$	2.4	3.4	–	V
Low Level Output Voltage	V_{OL}	$V_{CC} = \text{MIN}, V_{IL} = 0.8\text{V}, I_{OL} = 16\text{mA}$	–	0.2	0.4	V
Input Current	I_I	$V_{CC} = \text{MAX}, V_I = 5.5\text{V}$	–	–	1	mA

Note 2. For conditions shown as MIN or MAX, use the appropriate value specified under “Recommended Operation Conditions”.

Note 3. All typical values are at $V_{CC} = 5\text{V}, T_A = +25^\circ\text{C}$.

Electrical Characteristics (Cont'd): (Note 2, Note 3)

Parameter	Symbol	Test Conditions	Min	Typ	Max	Unit
High Level Input Current	I_{IH}	$V_{CC} = \text{MAX}, V_I = 2.4\text{V}$	-	-	40	μA
Low Level Input Current	I_{IL}	$V_{CC} = \text{MAX}, V_I = 0.4\text{V}$	-	-	-1.6	mA
Short-Circuit Output Current	I_{OS}	$V_{CC} = \text{MAX}, \text{Note 4}$	-18	-	-55	mA
High Level Supply Current	I_{CCH}	$V_{CC} = \text{MAX}, V_I = 4.5\text{V}$	-	11	21	mA
Low Level Supply Current	I_{CCL}	$V_{CC} = \text{MAX}, V_I = 0\text{V}$	-	20	33	mA

Note 2. For conditions shown as MIN or MAX, use the appropriate value specified under "Recommended Operation Conditions".

Note 3. All typical values are at $V_{CC} = 5\text{V}, T_A = +25^\circ\text{C}$.

Note 4. Not more than one output should be shorted at a time, and the duration of the short-circuit should not exceed one second.

Switching Characteristics: ($V_{CC} = 5\text{V}, T_A = +25^\circ\text{C}$ unless otherwise specified)

Parameter	Symbol	Test Conditions	Min	Typ	Max	Unit
Propagation Delay Time From A or B Input to Y Output)	t_{PLH}	$R_L = 400\Omega, C_L = 15\text{pF}$	-	17.5	27	ns
	t_{PHL}		-	12	19	ns

Truth Table (Each Gate):

Inputs		Output
A	B	Y
H	H	H
L	X	L
X	L	L

H = HIGH Voltage Level

L = LOW Voltage Level

X = Don't Care

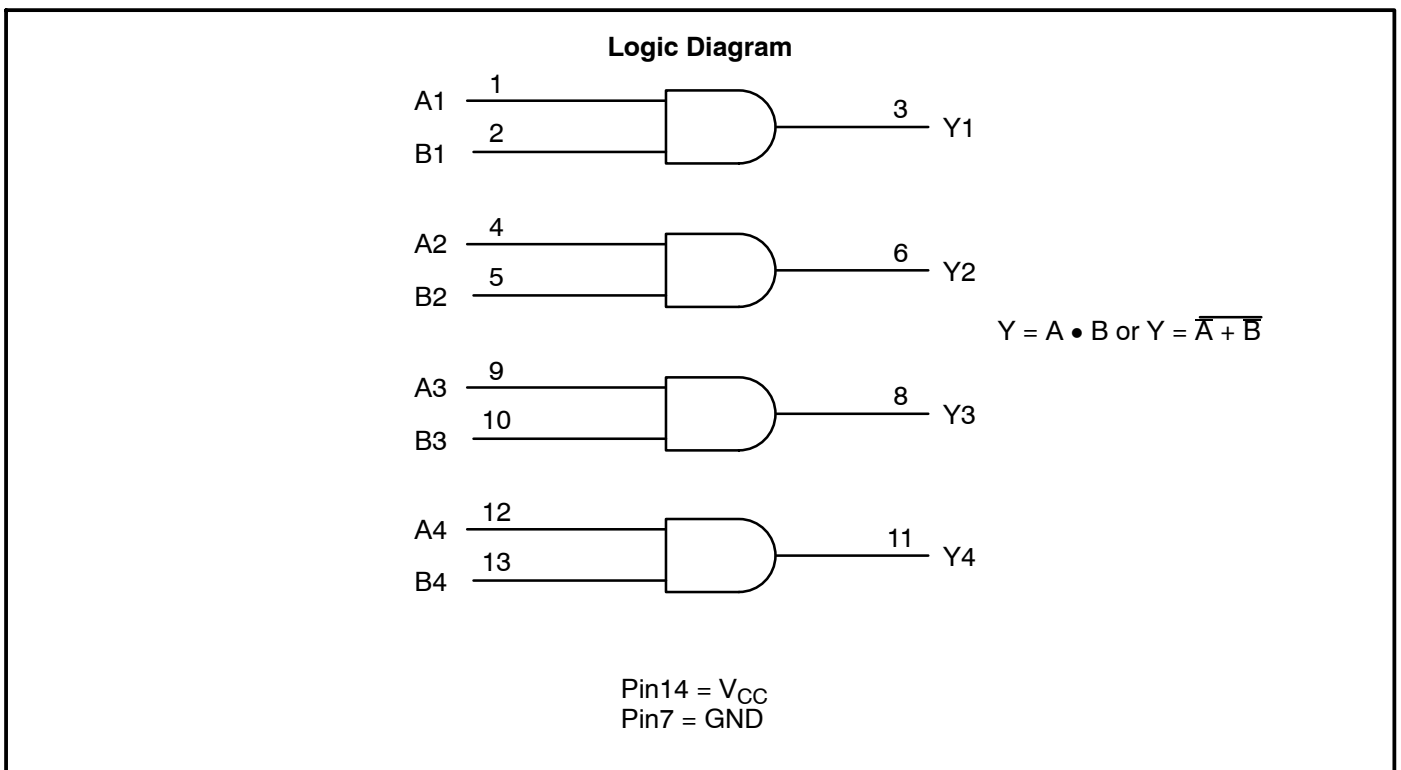

Pin Connection Diagram

