



PROPRIETARY NOTE

THIS SPECIFICATION IS THE PROPERTY OF BOE BJ AND SHALL NOT BE REPRODUCED OR COPIED WITHOUT THE WRITTEN PERMISSION OF BOE BJ AND MUST BE RETURNED TO BOE BJ UPON ITS REQUEST

SPEC. NUMBER

PRODUCT GROUP

Rev.

ISSUE DATE

PAGE

TFT-LCD

P0

2014.10.31

1 OF 33

NV125FHM-N62

Preliminary Product Specification

Rev. P0

HEFEI XINSHENG OPTOELECTRONICS TECHNOLOGY CO.,LTD



PRODUCT GROUP

REV

ISSUE DATE

TFT- LCD PRODUCT

P0

2014.10.31

SPEC. NUMBER

SPEC. TITLE
NV125FHM-N62 Preliminary Product Specification

PAGE

2 OF 33

REVISION HISTORY

REV.	ECN No.	DESCRIPTION OF CHANGES	DATE	PREPARED
P0	-	Initial Release	2014.10.31	Jin Zhen

Contents

No.	Items	Page
	REVISION HISTORY	2
	CONTENTS	3
1.0	General Description	4
2.0	Absolute Maximum ratings	6
3.0	Electrical specifications.	7
4.0	Optical specifications.	10
5.0	Interface Connection	15
6.0	Signal Timing Specification	18
7.0	Input Signals, Display Colors & Gray Scale of Colors	20
8.0	Power Sequence	21
9.0	Connector description	22
10.0	Mechanical Characteristics	23
11.0	Reliability Test	24
12.0	Handling & Cautions.	24
13.0	Label	25
14.0	Packing information	27
15.0	Mechanical Outline Dimension	28
16.0	EDID Table	30

BOE	PRODUCT GROUP	REV	ISSUE DATE
	TFT- LCD PRODUCT	P0	2014.10.31
SPEC. NUMBER	SPEC. TITLE		PAGE
	NV125FHM-N62 Preliminary Product Specification		4 OF 33

1.0 GENERAL DESCRIPTION

1.1 Introduction

NV125FHM-N62 is a color active matrix TFT LCD module using amorphous silicon TFT's (Thin Film Transistors) as an active switching devices. This module has a 12.5 inch diagonally measured active area with FHD resolutions (1920 horizontal by 1080 vertical pixel array). Each pixel is divided into RED, GREEN, BLUE dots which are arranged in vertical Stripe and this module can display 16.7M colors. The TFT-LCD panel used for this module is a low reflection and higher color type. Therefore, this module is suitable for Notebook PC. The LED Driver for back-light driving is built in this model. All input signals are eDP1.3 interface compatible.

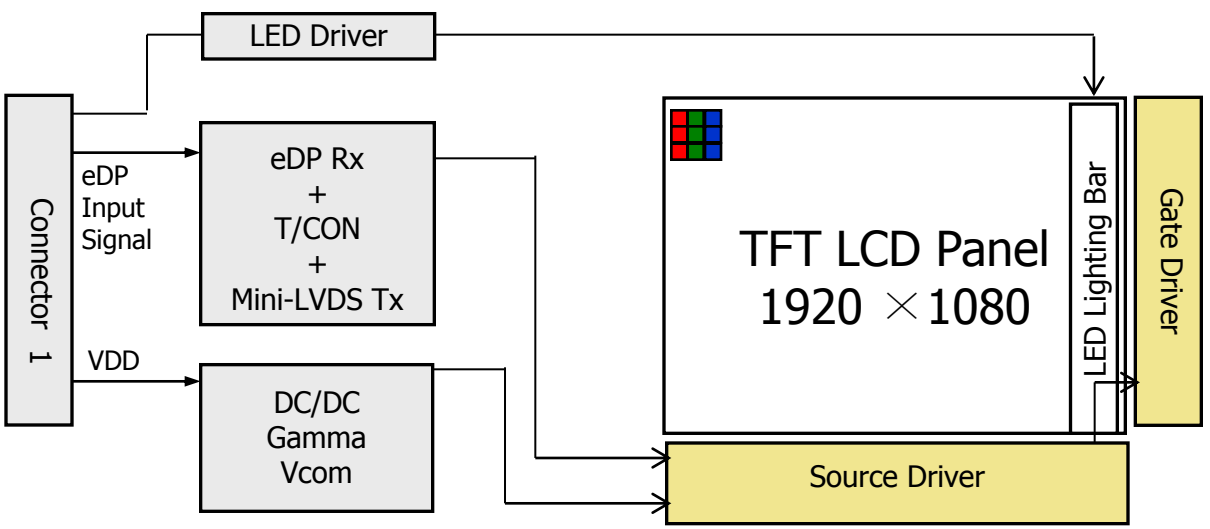

1.2 Features

- 2 lane eDP1.3 Interface with 1.62Gbps Link Rates
- Thin and light weight
- RGB 6-bit +Hi-FRC color depth, display 16.7M colors
- Single LED Lighting Bar. (Down side/Horizontal Direction)
- No Mounting frame
- Green Product (RoHS & Halogen free product)
- On board LED Driving circuit
- Low driving voltage and low power consumption
- On board EDID chip

SPEC. NUMBER

SPEC. TITLE

NV125FHM-N62 Preliminary Product Specification

PAGE

5 OF 33

1.3 Application

- Notebook PC (Wide type)

1.4 General Specification

The followings are general specifications at the model NV125FHM-N62. (listed in Table 1.)

<Table 1. General Specifications>

Parameter	Specification	Unit	Remarks
Active area	276.48(H) × 155.52(V)	mm	
Number of pixels	1920 (H) × 1080(V)	pixels	
Pixel pitch	0.144(H) × 0.144(V)	mm	
Pixel arrangement	RGB Vertical stripe		
Display colors	16.7M	colors	Hi-FRC
Display mode	Normally Black (HADS)		
Outline dimension	With PCB & Bracket : 300.4±0.5*180.9±0.5*2.85 Max W/O :290.5±0.5 * 170.7±0.5 * 2.85 Max	mm	
Weight	230 (max)	g	
Surface treatment	Anti-Glare		
Back-light	Lower Down side, 1-LED Lighting Bar type		Note 1
Power consumption	P _D : 1.2 (max)	W	R/G/B255
	P _{BL} :2.6(max)	W	
	P _{total} :3.8(max)	W	

Notes : 1. LED Lighting Bar (36*LED Array)

2.0 ABSOLUTE MAXIMUM RATINGS

The followings are maximum values which, if exceed, may cause faulty operation or damage to the unit. The operational and non-operational maximum voltage and current values are listed in Table 2.

< Table 2. Absolute Maximum Ratings >

Ta=25+/-2°C

Parameter	Symbol	Min.	Max.	Unit	Remarks
Power Supply Voltage	V _{DD}	-0.3	4.0	V	Note 1
Logic Supply Voltage	V _{IN}	V _{SS} -0.3	V _{DD} +0.3	V	
Operating Temperature	T _{OP}	0	+50	°C	Note 2
Storage Temperature	T _{ST}	-20	+60	°C	

- Notes : 1. Permanent damage to the device may occur if maximum values are exceeded functional operation should be restricted to the condition described under normal operating conditions.
2. Temperature and relative humidity range are shown in the figure below.
 95 % RH Max. (40 °C ≥ Ta)
 Maximum wet - bulb temperature at 39 °C or less. (Ta > 40 °C) No condensation.

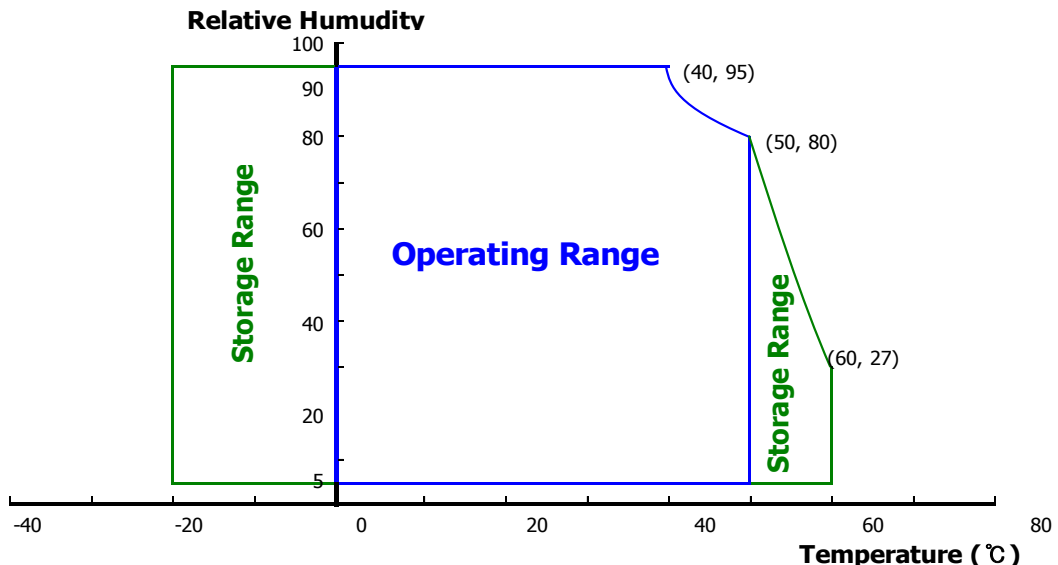

3.0 ELECTRICAL SPECIFICATIONS

3.1 Electrical Specifications

< Table 3. Electrical specifications >

Ta=25+/-2°C

Parameter		Min.	Typ.	Max.	Unit	Remarks
Power Supply Voltage	V _{DD}	3.0	3.3	3.6	V	Note 1
Permissible Input Ripple Voltage	V _{RF}	-	-	100	mV	At V _{DD} = 3.3V
Power Supply Current	I _{DD}	-	TBD	-	mA	Note 1
Differential Input Voltage	V _{ID}	200	-	600	mV	
Power Consumption	P _D	-	0.8	1.2	W	Note 1
	P _{BL}	-	-	2.6	W	Note 2
	P _{total}	-	-	3.8	W	

Notes : 1. The supply voltage is measured and specified at the interface connector of LCM.
The current draw and power consumption specified is for 3.3V at 25°C.

a) Typ : Mosaic Pattern

b) Max : R255 /G255 /B255 Pattern

2. Calculated value for reference (V_{LED} × I_{LED} / Efficiency)

7

3.2 Backlight Unit

< Table 4. LED Driving guideline specifications >

Ta=25+/-2°C

Parameter		Min.	Typ.	Max.	Unit	Remarks	
LED Forward Voltage		V_F	-	-	3.1	V	-
LED Forward Current		I_F	-	20.9	-	mA	-
LED Power Consumption		P_{LED}	-	-	2.6	W	Note 1
LED Life-Time		N/A	15,000	-	-	Hour	$I_F = 20mA$
Power supply voltage for LED Driver		V_{LED}	5	12	21	V	
EN Control Level	Backlight on		2.5		5.0	V	
	Backlight off		0		1.0	V	
PWM Control Level	PWM High Level		2.5		5.0	V	
	PWM Low Level		0		0.1	V	
PWM Control Frequency		F_{PWM}	100	-	10,000	Hz	
Duty Ratio		-	1	-	100	%	Note3

Notes : 1. Power supply voltage 12V for LED Driver

Calculator Value for reference $I_F \times V_F \times 36 / \text{efficiency} = P_{LED}$

2. The LED Life-time define as the estimated time to 50% degradation of initial luminous.

3. 1% duty cycle is achievable with a dimming frequency less than 1KHz.

3.3 LED structure

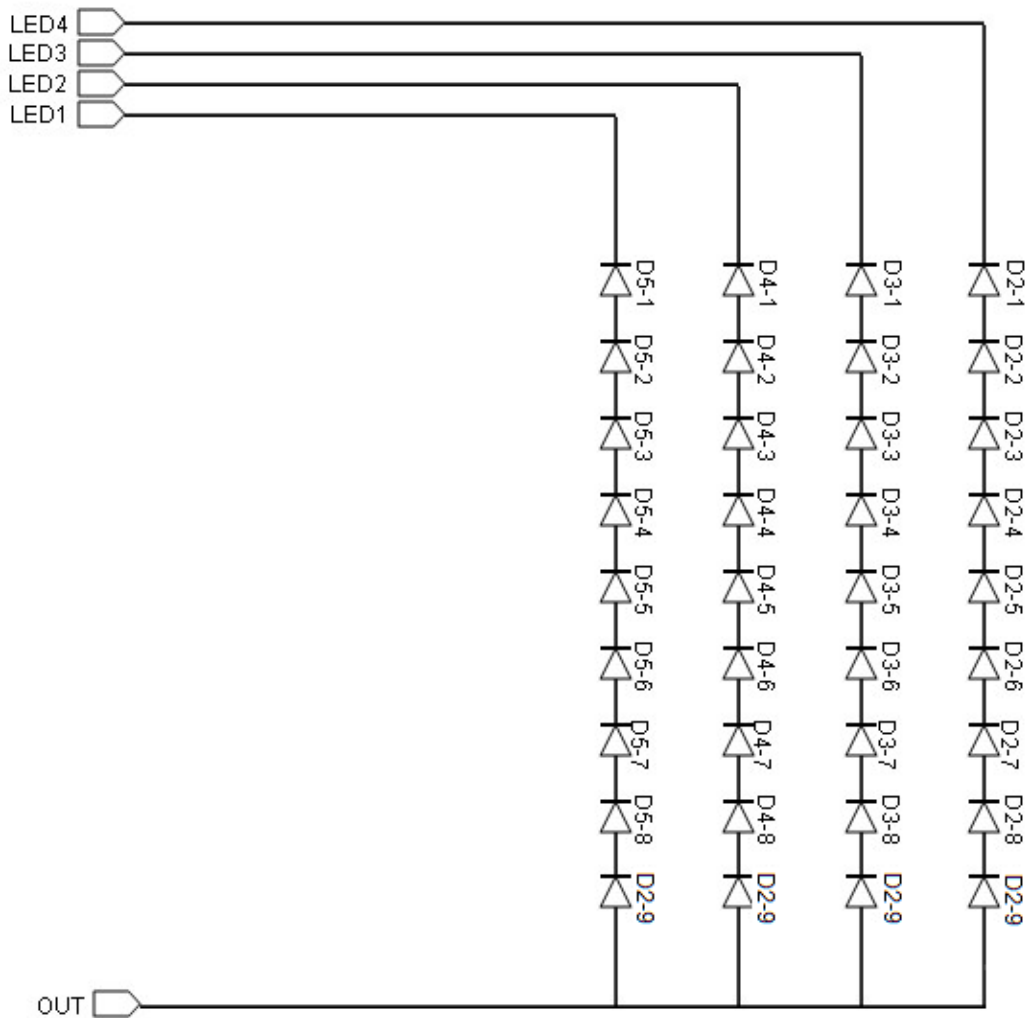

4.0 OPTICAL SPECIFICATION

4.1 Overview

The test of Optical specifications shall be measured in a dark room (ambient luminance ≤ 1 lux and temperature = $25 \pm 2^\circ\text{C}$) with the equipment of Luminance meter system (Goniometer system and TOPCON BM-5) and test unit shall be located at an approximate distance 50cm from the LCD surface at a viewing angle of θ and Φ equal to 0° . We refer to $\theta\Phi=0$ ($=\theta_3$) as the 3 o'clock direction (the "right"), $\theta\Phi=90$ ($=\theta_{12}$) as the 12 o'clock direction ("upward"), $\theta\Phi=180$ ($=\theta_9$) as the 9 o'clock direction ("left") and $\theta\Phi=270$ ($=\theta_6$) as the 6 o'clock direction ("bottom"). While scanning θ and/or Φ , the center of the measuring spot on the Display surface shall stay fixed. The backlight should be operating for 30 minutes prior to measurement. VDD shall be $3.3 \pm 0.3\text{V}$ at 25°C . Optimum viewing angle direction is 6 'clock.

4.2 Optical Specifications

<Table 5. Optical Specifications>

Parameter		Symbol	Condition	Min.	Typ.	Max.	Unit	Remark
Viewing Angle range	Horizontal	Θ_3	CR > 10	80	85	-	Deg.	Note 1
		Θ_9		80	85	-	Deg.	
	Vertical	Θ_{12}		80	85	-	Deg.	
		Θ_6		80	85	-	Deg.	
Luminance Contrast ratio		CR	$\Theta = 0^\circ$	600	800	-		Note 2
Luminance of White	5 Points	Y_w	$\Theta = 0^\circ$ $I_{LED} = 20\text{mA}$	255	300	-	cd/m ²	Note 3
White Luminance uniformity	5 Points	ΔY_5		80	-	-		Note 4
	13 Points	ΔY_{13}		65	-	-		
White Chromaticity		x_w	$\Theta = 0^\circ$	0.283	0.313	0.343		Note 5
		y_w		0.299	0.329	0.359		
Reproduction of color	Red	x_R	$\Theta = 0^\circ$	-0.03	0.610	+0.03		
		y_R			0.354			
	Green	x_G			0.333			
		y_G			0.569			
	Blue	x_B			0.155			
		y_B			0.122			
Gamut					50		%	
Response Time (Rising + Falling)		T_{RT}	$T_a = 25^\circ\text{C}$ $\Theta = 0^\circ$	-	30	35	ms	Note 6
Cross Talk		CT	$\Theta = 0^\circ$	-	-	2.0	%	Note 7

Notes :

1. Viewing angle is the angle at which the contrast ratio is greater than 10. The viewing angles are determined for the horizontal or 3, 9 o'clock direction and the vertical or 6, 12 o'clock direction with respect to the optical axis which is normal to the LCD surface (see FIGURE 1).

2. Contrast measurements shall be made at viewing angle of $\Theta = 0$ and at the center of the LCD surface. Luminance shall be measured with all pixels in the view field set first to white, then to the dark (black) state .

(see FIGURE 1) Luminance Contrast Ratio (CR) is defined mathematically.

$$CR = \frac{\text{Luminance when displaying a white raster}}{\text{Luminance when displaying a black raster}}$$

3. Center Luminance of white is defined as luminance values of 5 point average across the LCD surface. Luminance shall be measured with all pixels in the view field set first to white. This measurement shall be taken at the locations shown in FIGURE 2 for a total of the measurements per display.

4. The White luminance uniformity on LCD surface is then expressed as : $\Delta Y = \text{Minimum Luminance of 5(or 13) points} / \text{Maximum Luminance of 5(or 13) points}$.
(see FIGURE 2 and FIGURE 3).

5. The color chromaticity coordinates specified in Table 5 shall be calculated from the spectral data measured with all pixels first in red, green, blue and white. Measurements shall be made at the center of the panel.

6. The electro-optical response time measurements shall be made as FIGURE 4 by switching the "data" input signal ON and OFF. The times needed for the luminance to change from 10% to 90% is T_r , and 90% to 10% is T_d .

7. Cross-Talk of one area of the LCD surface by another shall be measured by comparing the luminance (Y_A) of a 25mm diameter area, with all display pixels set to a gray level, to the luminance (Y_B) of that same area when any adjacent area is driven dark.
(See FIGURE 5).

4.3 Optical measurements

Figure 1. Measurement Set Up

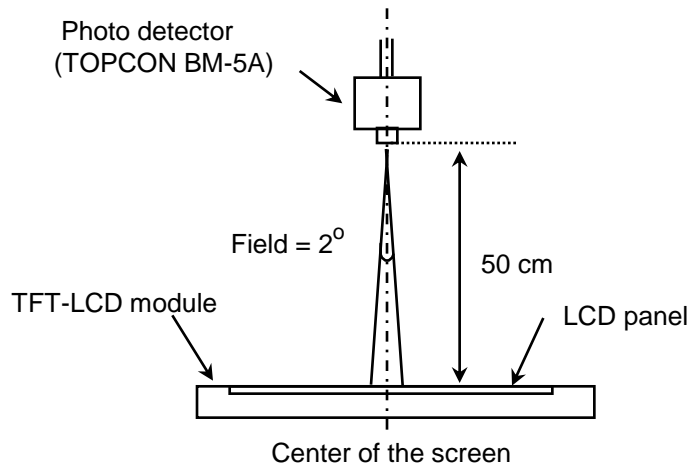

Optical characteristics measurement setup

Figure 2. White Luminance and Uniformity Measurement Locations (5 points)

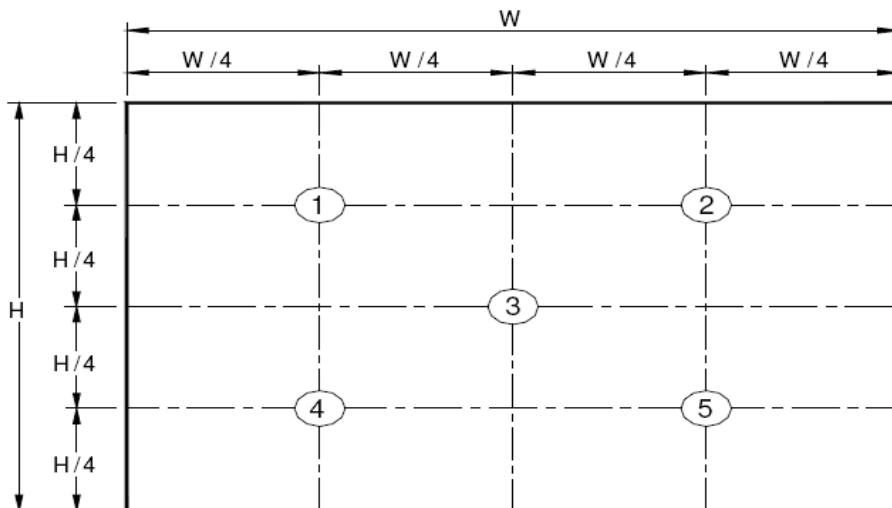

Center Luminance of white is defined as luminance values of center 5 points across the LCD surface. Luminance shall be measured with all pixels in the view field set first to white. This measurement shall be taken at the locations shown in FIGURE 2 for a total of the measurements per display.

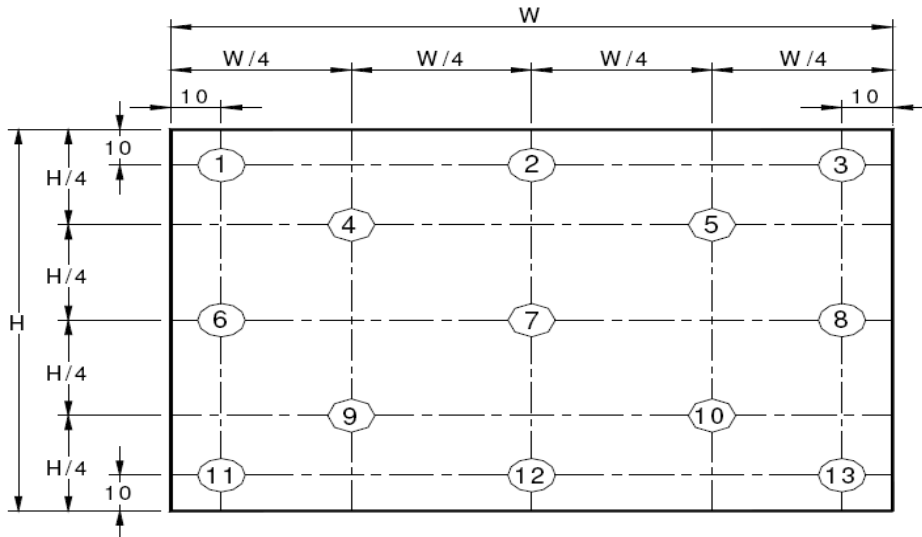
Figure 3. Uniformity Measurement Locations (13 points)

The White luminance uniformity on LCD surface is then expressed as : $\Delta Y_5 = \text{Minimum Luminance of five points} / \text{Maximum Luminance of five points}$ (see FIGURE 2) , $\Delta Y_{13} = \text{Minimum Luminance of 13 points} / \text{Maximum Luminance of 13 points}$ (see FIGURE 3).

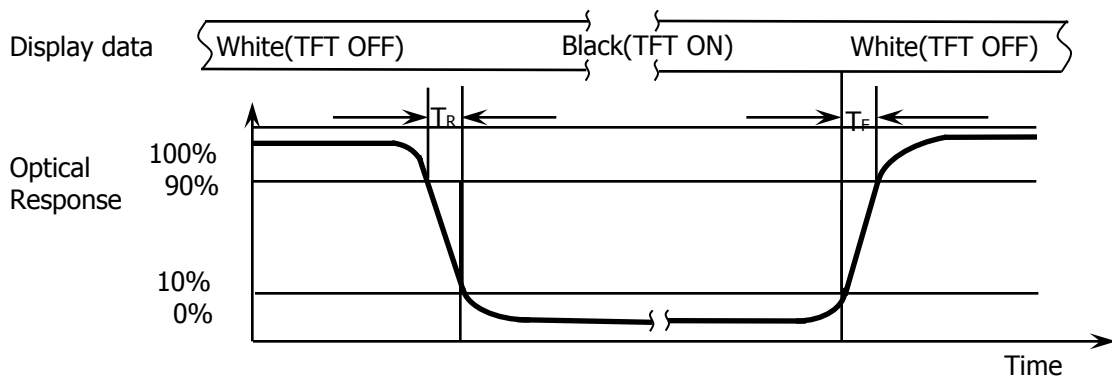
Figure 4. Response Time Testing

The electro-optical response time measurements shall be made as shown in FIGURE 4 by switching the “data” input signal ON and OFF. The times needed for the luminance to change from 10% to 90% is T_d and 90% to 10% is T_r .

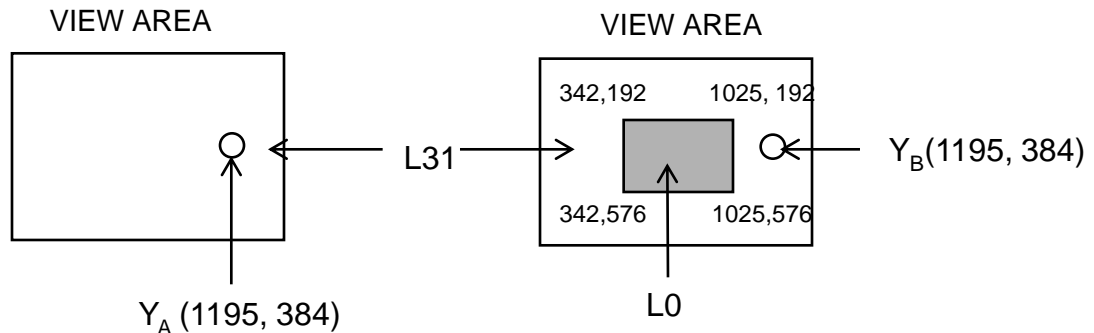
Figure 5. Cross Modulation Test Description

$$\text{Cross-Talk (\%)} = \left| \frac{Y_B - Y_A}{Y_A} \right| \times 100$$

Where:

Y_A = Initial luminance of measured area (cd/m^2)

Y_B = Subsequent luminance of measured area (cd/m^2)

The location measured will be exactly the same in both patterns

Cross-Talk of one area of the LCD surface by another shall be measured by comparing the luminance (Y_A) of a 25mm diameter area, with all display pixels set to a gray level, to the luminance (Y_B) of that same area when any adjacent area is driven dark (Refer to FIGURE 5).

5.0 INTERFACE CONNECTION.**5.1 Electrical Interface Connection**

The electronics interface connector is UJU IS050-L30B-C10 or Compatible.

The connector interface pin assignments are listed in Table 6.

<Table 6. Pin Assignments for the Interface Connector>

Terminal	Symbol	Functions
Pin No.	Symbol	Description
1	DBC	Enable
2	H_GND	Ground
3	LANE1_N	eDP RX channel 1 negative
4	LANE1_P	eDP RX channel 1 positive
5	H_GND	Ground
6	LANE0_N	eDP RX channel 0 negative
7	LANE0_P	eDP RX channel 0 positive
8	H_GND	Ground
9	AUX_CH_P	eDP AUX CH positive
10	AUX_CH_N	eDP AUX CH negative
11	H_GND	Ground
12	LCD_VCC	Power Supply, 3.3V (typ.)
13	LCD_VCC	Power Supply, 3.3V (typ.)
14	LCD_Self_Test	Panel self test enable
15	H_GND	Ground
16	H_GND	Ground
17	HPD	Hot plug detect output
18	BL_GND	LED Ground
19	BL_GND	LED Ground
20	BL_GND	LED Ground
21	BL_GND	LED Ground
22	BL_ENABLE	LED enable pin(+3.3V Input)
23	BL_PWM	System PWM Signal Input
24	H-sync	H-sync
25	NC	No Connection
26	BL_POWER	LED Power Supply 5V-21V
27	BL_POWER	LED Power Supply 5V-21V
28	BL_POWER	LED Power Supply 5V-21V
29	BL_POWER	LED Power Supply 5V-21V
30	NC	No Connection

5-2. eDP Interface

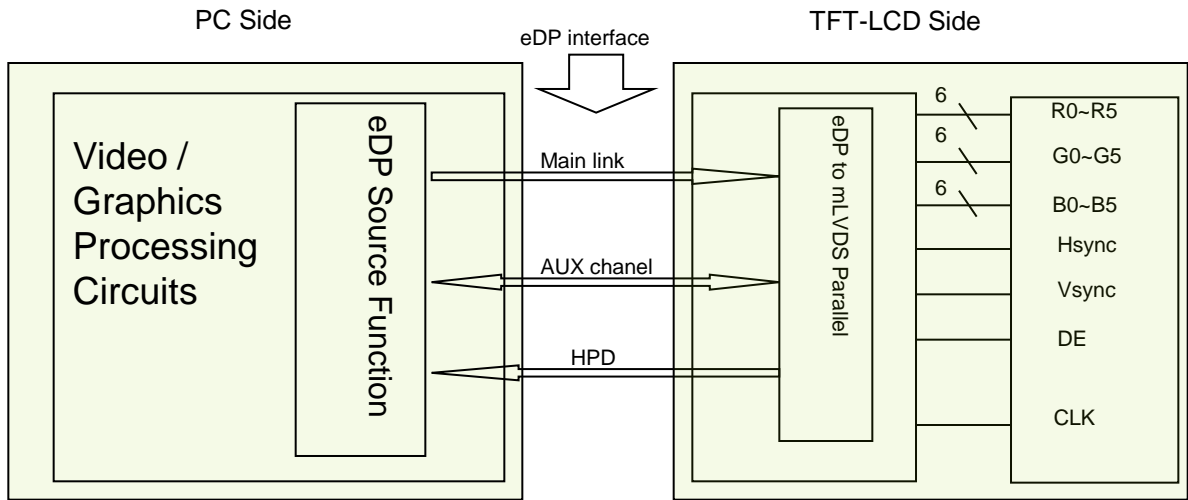

Note. Transmitter : : NT71392 or equivalent.

Transmitter is not contained in Module.

5.3.eDP Input signal

Lane 0	
R0-5:0	G0-5:4
G0-3:0	B0-5:2
B0-1:0	R1-5:0
G1-5:0	B1-5:4
B1-3:0	R2-5:2
R2-1:0	G2-5:0
B2-5:0	R3-5:4
R3-3:0	G3-5:2
G3-1:0	B3-5:0

5.4 Back-light & LCM Interface Connection

Interface Connector: **CRT F10401-1092**

<Table 7. Pin Assignments for the BLU & LCM Connector>

Pin No.	Symbol	Description	Pin No.	Symbol	Description
1	LED1	LED cathode connection	6	NC	No Connection
2	LED2	LED cathode connection	7	Vout	LED anode connection
3	LED3	LED cathode connection	8	Vout	LED anode connection
4	LED4	LED cathode connection	9	Vout	LED anode connection
5	NC	No Connection			

6.0 SIGNAL TIMING SPECIFICATION

6.1 The NV125FHM-N62 is operated by the DE only.

Item		Symbols	Min	Typ	Max	Unit
Clock	Frequency	1/Tc	100	141.4	160	MHz
	High Time	Tch	-	4/7Tc	-	Tc
	Low Time	Tcl	-	4/7Tc	-	Tc
Frame Period		Tv	1090	1100	1238	lines
			40	60	66	Hz
			22.93	15.15	12.23	ms
Vertical Display Period		Tvd	-	1080	-	lines
One line Scanning Period		Th	2080	2142	2400	clocks
Horizontal Display Period		Thd	-	1920	-	clocks

Note*: This Module can support low frame refresh rate 50Hz & 40Hz.

6.2 eDP Rx Interface Timing Parameter

The specification of the eDP Rx interface timing parameter is shown in Table 8.

<Table 8. eDP Rx Interface Timing Specification>

Item	Symbol	Min	Typ	Max	Unit	Remark
Spread spectrum clock	SSC		0.5		%	
Differential peak-to-peak input voltage at package pins	VRX-DIFFp-p	100	0	1320	mV	
Rx input DC common mode voltage	VRX_DC_CM	-	GND	-	V	
Differential termination resistance	RRX-DIFF	80	-	100	Ω	
Single-ended termination resistance	RRX-SE	40	-	60	Ω	
Rx short circuit current limit	IRX_SHORT	-	-	20	mA	
Intra-pair skew at Rx package pins (HBR) RX intra-pair skew tolerance at HBR	LRX_SKEW_INTRA_PAIR	-	-	150	ps	

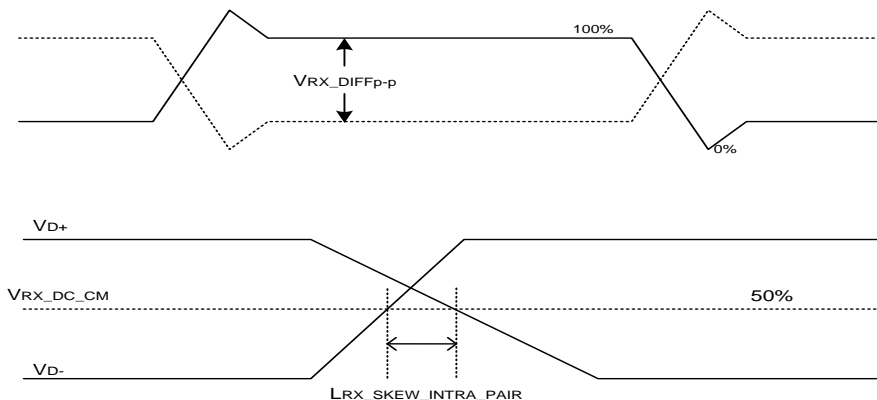

7.0 INPUT SIGNALS, BASIC DISPLAY COLORS & GRAY SCALE OF COLORS

	Colors & Gray scale	Data signal																	
		R0	R1	R2	R3	R4	R5	G0	G1	G2	G3	G4	G5	B0	B1	B2	B3	B4	B5
Basic colors	Black	0	0	0	0	0	0	0	0	0	0	0	0	0	0	0	0	0	0
	Blue	0	0	0	0	0	0	0	0	0	0	0	0	1	1	1	1	1	1
	Green	0	0	0	0	0	0	1	1	1	1	1	1	0	0	0	0	0	0
	Light Blue	0	0	0	0	0	0	1	1	1	1	1	1	1	1	1	1	1	1
	Red	1	1	1	1	1	1	0	0	0	0	0	0	0	0	0	0	0	0
	Purple	1	1	1	1	1	1	0	0	0	0	0	0	1	1	1	1	1	1
	Yellow	1	1	1	1	1	1	1	1	1	1	1	1	0	0	0	0	0	0
	White	1	1	1	1	1	1	1	1	1	1	1	1	1	1	1	1	1	1
Gray scale of Red	Black	0	0	0	0	0	0	0	0	0	0	0	0	0	0	0	0	0	0
	△	1	0	0	0	0	0	0	0	0	0	0	0	0	0	0	0	0	0
	Darker	0	1	0	0	0	0	0	0	0	0	0	0	0	0	0	0	0	0
	△	↑						↑						↑					
	▽	↓						↓						↓					
	Brighter	1	0	1	1	1	1	0	0	0	0	0	0	0	0	0	0	0	0
	▽	0	1	1	1	1	1	0	0	0	0	0	0	0	0	0	0	0	0
	Red	1	1	1	1	1	1	0	0	0	0	0	0	0	0	0	0	0	0
Gray scale of Green	Black	0	0	0	0	0	0	0	0	0	0	0	0	0	0	0	0	0	0
	△	0	0	0	0	0	0	1	0	0	0	0	0	0	0	0	0	0	0
	Darker	0	0	0	0	0	0	0	1	0	0	0	0	0	0	0	0	0	0
	△	↑						↑						↑					
	▽	↓						↓						↓					
	Brighter	0	0	0	0	0	0	1	0	1	1	1	1	0	0	0	0	0	0
	▽	0	0	0	0	0	0	0	1	1	1	1	1	0	0	0	0	0	0
	Green	0	0	0	0	0	0	1	1	1	1	1	1	0	0	0	0	0	0
Gray scale of Blue	Black	0	0	0	0	0	0	0	0	0	0	0	0	0	0	0	0	0	0
	△	0	0	0	0	0	0	0	0	0	0	0	0	1	0	0	0	0	0
	Darker	0	0	0	0	0	0	0	0	0	0	0	0	0	1	0	0	0	0
	△	↑						↓						↑					
	▽	↓						↓						↓					
	Brighter	0	0	0	0	0	0	0	0	0	0	0	0	1	0	1	1	1	1
	▽	0	0	0	0	0	0	0	0	0	0	0	0	0	1	1	1	1	1
	Blue	0	0	0	0	0	0	0	0	0	0	0	0	1	1	1	1	1	1
Gray scale of White & Black	Black	0	0	0	0	0	0	0	0	0	0	0	0	0	0	0	0	0	0
	△	1	0	0	0	0	0	1	0	0	0	0	0	1	0	0	0	0	0
	Darker	0	1	0	0	0	0	0	1	0	0	0	0	0	1	0	0	0	0
	△	↑						↑						↑					
	▽	↓						↓						↓					
	Brighter	1	0	1	1	1	1	1	0	1	1	1	1	1	0	1	1	1	1
	▽	0	1	1	1	1	1	0	1	1	1	1	1	0	1	1	1	1	1
	White	1	1	1	1	1	1	1	1	1	1	1	1	1	1	1	1	1	1

8.0 POWER SEQUENCE

To prevent a latch-up or DC operation of the LCD module, the power on/off sequence shall be as shown in below

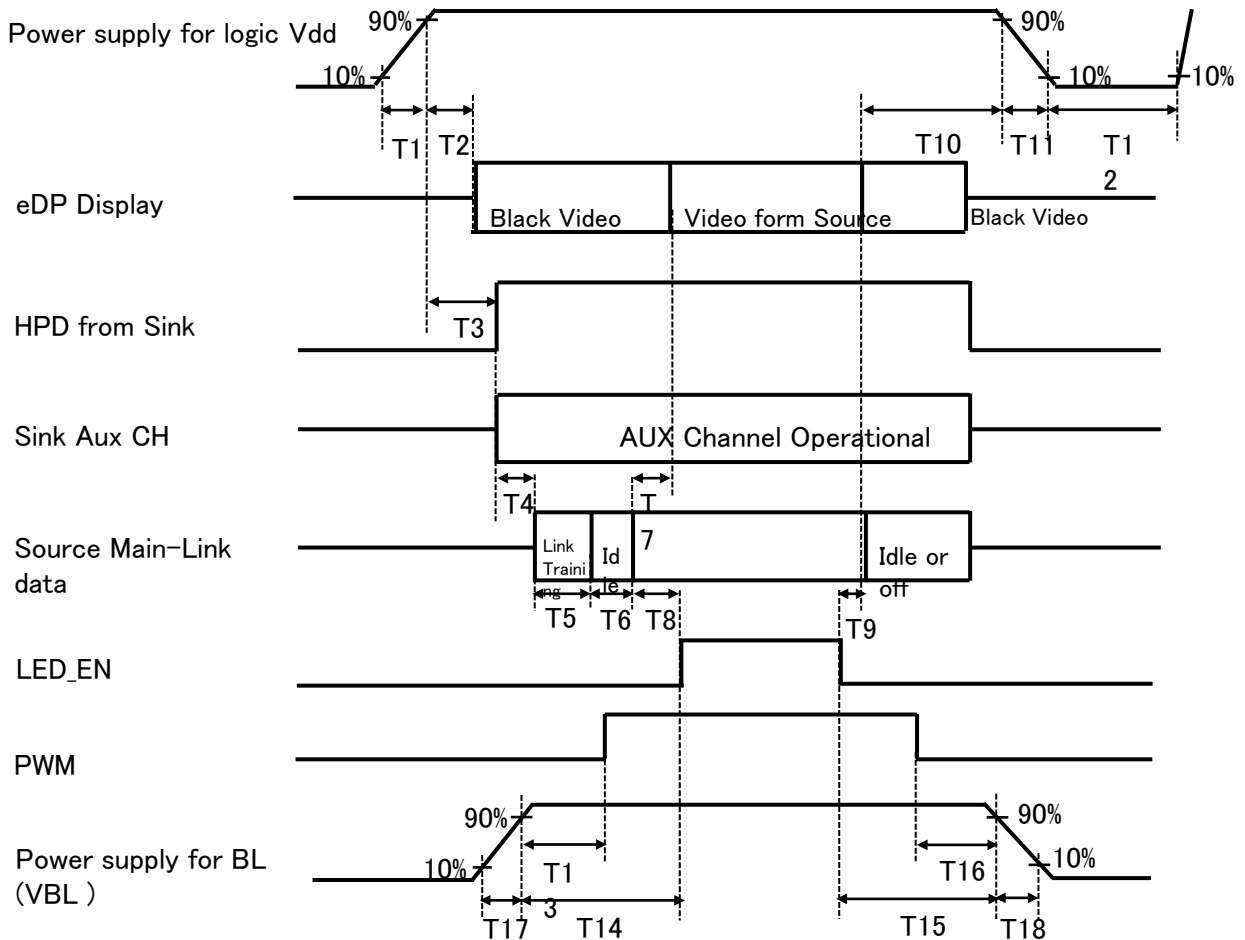

- 0.5ms ≤ T1 ≤ 10 ms
- 0ms ≤ T2 ≤ 200 ms
- 0ms ≤ T3 ≤ 200 ms
- 0ms ≤ T13
- 0ms ≤ T14
- 0ms ≤ T17

- 0ms ≤ T7 ≤ 50ms
- 0ms ≤ T10 ≤ 500 ms
- 0 ms ≤ T11 ≤ 10 ms
- 150ms ≤ T12
- 0ms ≤ T15
- 0ms ≤ T16
- 0ms ≤ T18

Notes:

1. When the power supply VDD is 0V, keep the level of input signals on the low or keep high impedance.
2. Do not keep the interface signal high impedance when power is on. Back Light must be turn on after power for logic and interface signal are valid.

9.0 Connector Description

Physical interface is described as for the connector on LCM.

These connectors are capable of accommodating the following signals and will be following components.

9.1 TFT LCD Module

Connector Name /Description	For Signal Connector
Manufacturer	UJU or Compatible
Type/ Part Number	IS050-L30B-C10 or Compatible
Mating housing/ Part Number	I-PEX 20454-030T or Compatible

10.0 MECHANICAL CHARACTERISTICS

10.1 Dimensional Requirements

FIGURE 6 shows mechanical outlines for the model NV125FHM-N62.
Other parameters are shown in Table 9.

<Table 9. Dimensional Parameters>

Parameter	Specification	Unit
Active Area	276.48(H) x 155.52(V)	
Number of pixels	1920 (H) X 1080 (V) (1 pixel = R + G + B dots)	
Pixel pitch	0.144 (H) X 0.144 (V)	
Pixel arrangement	RGB Vertical stripe	
Display colors	16.7M	
Display mode	HADS	
Dimensional outline	With PCB & Bracket : 300.4±0.5*180.9±0.5*2.85 Max W/O :290.5±0.5 * 170.7±0.5 * 2.85 Max	mm
Weight	230(Max)	gram
Back Light	Connector :CRT F10401-1092	
	LED, Horizontal-LED Array type	

10.2 Mounting

See FIGURE 6.

10.3 Glare and Polarizer Hardness.

The surface of the LCD has an glare coating to maximize readability and hard coating to reduce scratching.

10.4 Light Leakage

There shall not be visible light from the back-lighting system around the edges of the screen as seen from a distance 50cm from the screen with an overhead light level of 350lux.

11.0 RELIABILITY TEST

The Reliability test items and its conditions are shown in below.

<Table 10. Reliability test>

No	Test Items	Conditions
1	High temperature storage test	Ta = 60 °C, 240 hrs
2	Low temperature storage test	Ta = -20 °C, 240 hrs
3	High temperature & high humidity operation test	Ta = 50 °C, 80%RH, 240 hrs
4	High temperature operation test	Ta = 50 °C, 240 hrs
5	Low temperature operation test	Ta = 0 °C, 240 hrs
6	Thermal shock	Ta = -20 °C ↔ 60 °C (0.5 hr), 100 cycle
7	Vibration test (non-operating)	1.5G, 10~500Hz, Half Sine X,Y,Z / Sweep rate : 1 hour
8	Shock test (non-operating)	220G, Half Sine Wave 2msec ±X, ±Y, ±Z Once for each direction
9	Electro-static discharge test (non-operating)	Air : 150 pF, 330Ω, 15 KV Contact : 150 pF, 330Ω, 8 KV

12.0 HANDLING & CAUTIONS

(1) Cautions when taking out the module

- Pick the pouch only, when taking out module from a shipping package.

(2) Cautions for handling the module

- As the electrostatic discharges may break the LCD module, handle the LCD module with care. Peel a protection sheet off from the LCD panel surface as slowly as possible.
- As the LCD panel and back - light element are made from fragile glass material, impulse and pressure to the LCD module should be avoided.
- As the surface of the polarizer is very soft and easily scratched, use a soft dry cloth without chemicals for cleaning.
- Do not pull the interface connector in or out while the LCD module is operating.
- Put the module display side down on a flat horizontal plane.
- Handle connectors and cables with care.

(3) Cautions for the operation

- When the module is operating, do not lose CLK, ENAB signals. If any one of these signals is lost, the LCD panel would be damaged.
- Obey the supply voltage sequence. If wrong sequence is applied, the module would be damaged.

BOE	PRODUCT GROUP	REV	ISSUE DATE
	TFT- LCD PRODUCT	P0	2014.10.31
SPEC. NUMBER	SPEC. TITLE NV125FHM-N62 Preliminary Product Specification		PAGE 25 OF 33

- (4) Cautions for the atmosphere
 - Dew drop atmosphere should be avoided.
 - Do not store and/or operate the LCD module in a high temperature and/or humidity atmosphere. Storage in an electro-conductive polymer packing pouch and under relatively low temperature atmosphere is recommended.
- (5) Cautions for the module characteristics
 - Do not apply fixed pattern data signal to the LCD module at product aging.
 - Applying fixed pattern for a long time may cause image sticking.
- (6) Other cautions
 - Do not disassemble and/or re-assemble LCD module.
 - Do not re-adjust variable resistor or switch etc.
 - When returning the module for repair or etc., Please pack the module not to be broken. We recommend to use the original shipping packages.

13.0 LABEL

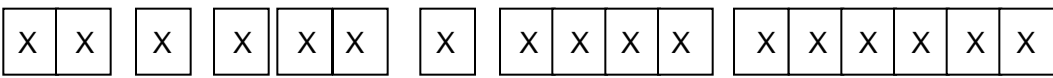

Type designation	No 5. Month (1, 2, 3, ..., 9, X, Y, Z)
No 1. Control Number	No 6. Product Identification (FG)
No 2. Rank / Grade	No 7. Serial Number
No 3. Line classification	
No 4. Year (10 : 2010, 11: 2011, ...)	

BOE	PRODUCT GROUP	REV	ISSUE DATE
	TFT- LCD PRODUCT	P0	2014.10.31
SPEC. NUMBER	SPEC. TITLE NV125FHM-N62 Preliminary Product Specification		PAGE 26 OF 33

(2) High voltage caution label

	HIGH VOLTAGE CAUTION	COLD CATHODE FLUORESCENT LAMP IN LCD PANEL CONTAINS A SMALL AMOUNT OF MERCURY. PLEASE FOLLOW LOCAL ORDINANCES OR REGULATIONS FOR DISPOSAL.
	RISK OF ELECTRIC SHOCK. DISCONNECT THE ELECTRIC POWER BEFORE SERVICING	

(3) Box label



京东方 BOE **HEFEI XINSHENG OPTOELECTRONICS TECHNOLOGY Co., LTD**
 MODEL: XXXXXXXX-XXX ① QTY: XX ②
 SERIAL NO: XXXXXXXXXXXX ③ DATE: XXXX/XX/XX ④
 Box ID 条形码
 XXXX-XXXXXX ⑤ XXXX ⑥ XXXXX ⑦
RoHS Compliant

Serial number marked part needs to print, As follows

1. FG-CODE
2. Product Quantity
3. Box ID
4. Packing Date
5. Customer Part No.--Empty
6. the last four numbers FG-Code I
7. Vendor Code --- Empty

Total Size:110×55mm

Digit	1	2	3	4	5	6	7	8	9	10	11	12	13
Code	S	L	S	5	1	2	3	D	0	0	0	6	8
Description	Products GBN		Grade	Line	Year		Month	Revision Code	SerialNo				

15.0 PACKING INFORMATION

15.1 Packing order

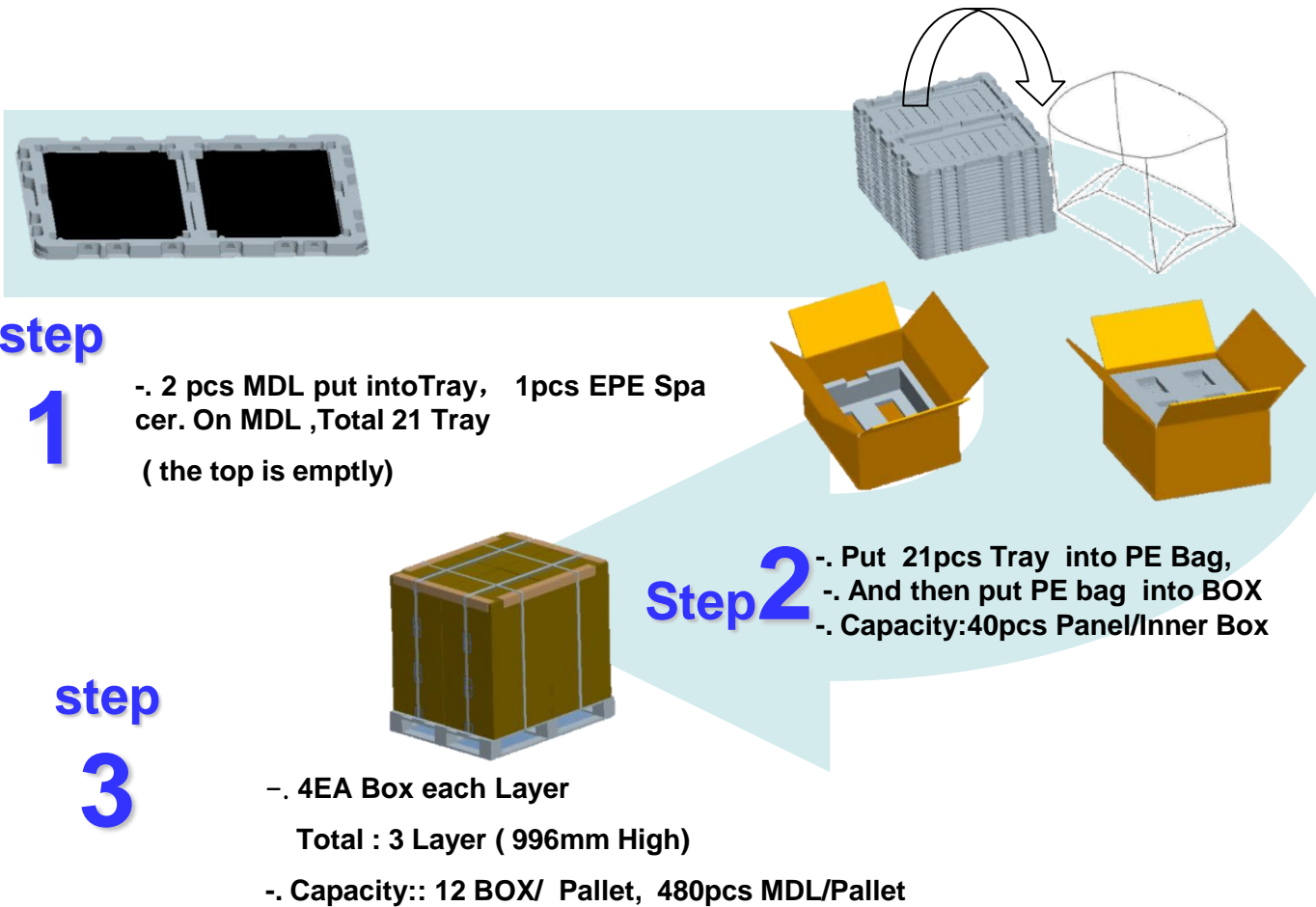

15.2 Notes

- Box Dimension:
- Package Quantity in one Box: 40 pcs
- Total Weight: kg

16.0 MECHANICAL OUTLINE DIMENSION

Figure 6. TFT-LCD Module Outline Dimension (Front View)

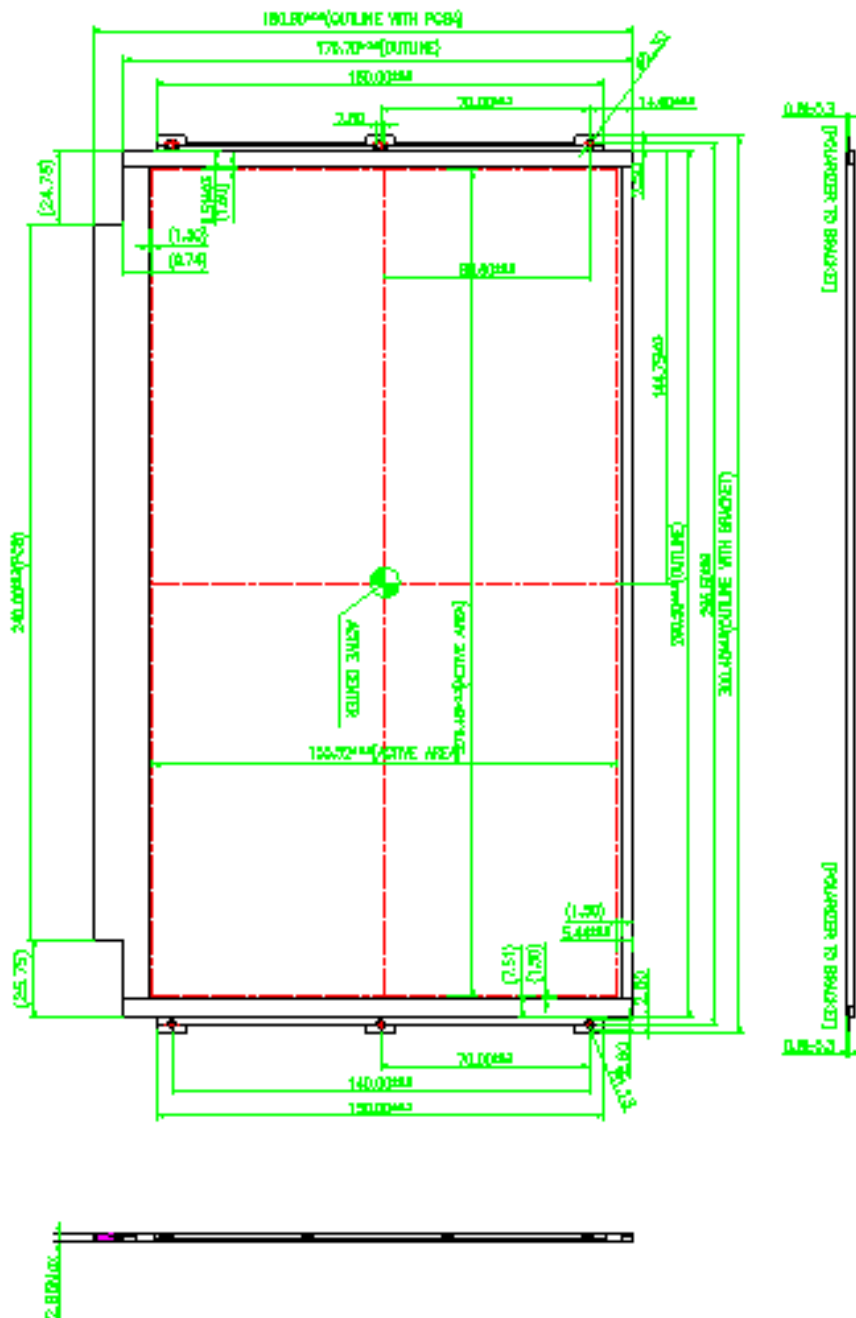
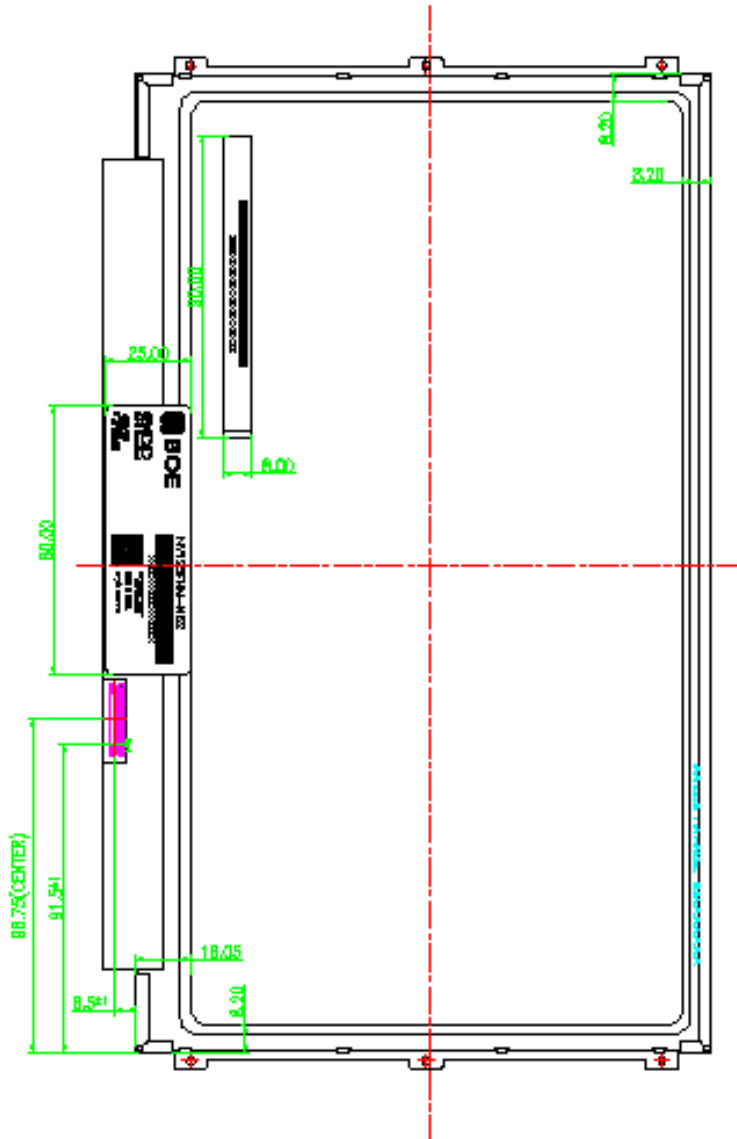

Figure 7. TFT-LCD Module Outline Dimensions (Rear view)



17.0 EDID Table

Address (HEX)	Function	Hex	Dec	Input values.	Notes
00	Header	00	0	0	EDID Header
01		FF	255	255	
02		FF	255	255	
03		FF	255	255	
04		FF	255	255	
05		FF	255	255	
06		FF	255	255	
07		00	0	0	
08	ID Manufacturer Name	09	9	BOE	ID = BOE
09		E5	229		
0A	ID Product Code	15	21	1557	ID = 1557
0B		06	6		
0C	32-bit	00	0		
0D					
0E		00			
0F		00			
10	Week of manufacture	01			
11	Year of Manufacture	18			Manufacture 2012
12	EDID Structure Version	01		1	EDID 1.0
13	EDID revision	04		4	EDID 1.0.4
14	Video input definition	95			
15	Max H image size	22			19 cm (Approx)
16	Max V image size	13	19	19	19 cm (Approx)
17	Display Gamma	78	120	2.2	Gamma curve = 2.2
18	Feature support	0A	10		RGB display, Preferred Timming mode
19	Red/Green low bits	FB	251	-	Red / Green Low Bits
1A	Blue/White low bits	0F	15	-	Blue / White Low Bits
1B	Red x high bits	95	149	0.585	Red (x) = 10010101 (0.585)
1C	Red y high bits	58	88	0.347	Red (y) = 01011000 (0.347)
1D	Green x high bits	55	85	0.334	Green (x) = 01010101 (0.334)
1E	Green y high bits	91	145	0.566	Green (y) = 10010001 (0.566)
1F	Blue x high bits	2A	42	0.165	Blue (x) = 00101010 (0.165)
20	Blue y high bits	1E	30	0.118	Blue (y) = 00011110 (0.118)
21	White x high bits	4F	79	0.312	White (x) = 01001111 (0.312)
22	White y high bits	56	86	0.339	White (y) = 01010110 (0.339)
23	Established timing 1	00	0	-	
24	Established timing 2	00	0	-	

T B D

25	Established timing 3	00	0	-	
26	Standard timing #1	01	1		Not Used
27		01	1		
28	Standard timing #2	01	1		Not Used
29		01	1		
2A	Standard timing #3	01	1		Not Used
2B		01	1		
2C	Standard timing #4	01	1		Not Used
2D		01	1		
2E	Standard timing #5	01	1		Not Used
2F		01	1		
30	Standard timing #6	01	1		Not Used
31		01	1		
32	Standard timing #7	01	1		Not Used
33		01	1		
34	Standard timing #8	01	1		Not Used
35		01	1		
36	Detailed timing/monitor descriptor #1	64	80	70.125	70.12MHz pixel clock
37		1B		120	Hor Active = 1366
38		56			Ver Active = 1000
39		77			Ver Blanking = 119
3A		50	80	-	4 bits of Hor. Active + 4 bits of Hor. Blanking
3B		00	0	768	Ver Active = 768
3C		13	19	19	Ver Blanking = 19
3D		30	48	-	4 bits of Ver. Active + 4 bits of Ver. Blanking
3E		30	48	48	Hor Sync Offset = 48
3F		20	32	32	H Sync Pulse Width = 32
40	36	54	3	V sync Offset = 3 line	
41	00	0	6	V Sync Pulse width : 6 line	
42	35	53	309	Horizontal Image Size = 309 mm (Low 8 bits)	
43	AD	173	173	Vertical Image Size = 173 mm (Low 8 bits)	
44	10	16	-	4 bits of Hor Image Size + 4 bits of Ver Image Size	
45	00	0	0	Hor Border (pixels)	
46	00	0	0	Vertical Border (Lines)	
47	1A	26		Refer to right table	

TBD

48	Detailed timing/monitor descriptor #2	A2	162	60.5	60.5MHz Main clock
49		17	23		
4A		56	86	1366	Hor Active = 1366
4B		B9	185	185	Hor Blanking = 185
4C		50	80	-	4 bits of Hor. Active + 4 bits of Hor. Blanking
4D		00	0	768	Ver Active = 768
4E		2D	45	45	Ver Blanking = 45
4F		30	48	-	4 bits of Ver. Active + 4 bits of Ver. Blanking
50		30	48	48	Hor Sync Offset = 48
51		20	32	32	H Sync Pulse Width = 32
52		36	54	3	V sync Offset = 3 line
53		00	0	6	V Sync Pulse width : 6 line
54		35	53	309	Horizontal Image Size = 309 mm (Low 8 bits)
55		4D	173	173	Vertical Image Size = 173 mm (Low 8 bits)
56		10			4 bits of Hor. Active + 4 bits of Ver Image
57		00			Hor Border (pixels)
58	00			Vertical Border (Lines)	
59	1A				
5A	00				
5B	00				
5C	00			Data Sting Tag	
5D	FE	254			
5E	00	0			
5F	32	50	2		
60	47	71	G		
61	43	67	C	D/PN:2GC9W	
62	39	57	9		
63	57	87	W		
64	80	128	10000000	EDID:A00	
65	4E	78	N		
66	54	84	T		
67	31	49	1		
68	35	53	5	BOE PN	
69	36	54	6		
6A	57	87	W		
6B	48	72	H		

TBD

6C		00	0		
6D		00	0		
6E		00	0		Product Name Tag (ASCII)
6F		00	0		
70		00	0		
71		00	0	00000000	6-bit Color Depth & no FRC
72		41	65	01000001	WLED & singal light bar & one light bar
73		01	1	00000001	Frame rate 40Hz~65Hz
74	Detailed timing/monitor descriptor #4	94	148	10010100	Light Controller:PWM & Max. Luminance 200
75		01	1	00000001	Front Surface: Glare & RGB v-stripe
76		10	16	00010000	NTSC & DBC
77		00	0	00000000	no Motion Blur & no Active Gamma
78		00	0	00000000	no Wireless Enhancement & no In-Cell Scanner
79		09	9	00001001	1 lane edp1.2
7A		01	1	00000001	Built-In Self Test
7B					
7C		20			
7D		20			
7E	Extension flag	00			
7F	Checksum	5F			

TBD