



**PROPRIETARY NOTE**

THIS SPECIFICATION IS THE PROPERTY OF BOE BJ AND SHALL NOT BE REPRODUCED OR COPIED WITHOUT THE WRITTEN PERMISSION OF BOE BJ AND MUST BE RETURNED TO BOE BJ UPON ITS REQUEST

SPEC. NUMBER

PRODUCT GROUP

Rev.

ISSUE DATE

PAGE

TFT-LCD

P0

2014.11.13

1 OF 32

**NV140FHM-N41**

**Preliminary Product Specification Rev. P0**

BEIJING BOE DISPLAY TECHNOLOGY

**BOE**

PRODUCT GROUP

REV

ISSUE DATE

TFT- LCD PRODUCT

P0

2014.11.13

SPEC. NUMBER

SPEC. TITLE

NV140FHM-N41 Preliminary Product Specification

PAGE

2 OF 32

## REVISION HISTORY

REV.	ECN No.	DESCRIPTION OF CHANGES	DATE	PREPARED
P0	-	Initial Release	2014.11.13	周波

## Contents

<b>No.</b>	<b>Items</b>	<b>Page</b>
1.0	General Description	5
2.0	Absolute Maximum ratings	7
3.0	Electrical specifications.	9
4.0	Optical specifications.	11
5.0	Interface Connection	16
6.0	Signal Timing Specification	18
7.0	Input Signals, Display Colors & Gray Scale of Colors	22
8.0	Power Sequence	22
9.0	Connector description	23
10.0	Mechanical Characteristics	24
11.0	Reliability Test	25
12.0	Handling & Cautions.	25
13.0	Label	26
14.0	Packing information	28
15.0	Mechanical Outline Dimension	29
16.0	EDID Table	31

## 1.0 GENERAL DESCRIPTION

### 1.1 Introduction

NV140FHM-N41 is a color active matrix TFT LCD module using amorphous silicon TFT's (Thin Film Transistors) as an active switching devices. This module has a 14.0 inch diagonally measured active area with FHD resolutions (1920 horizontal by 1080 vertical pixel array). Each pixel is divided into RED, GREEN, BLUE dots which are arranged in vertical Stripe and this module can display 262,144 colors. The TFT-LCD panel used for this module is a low reflection and higher color type. Therefore, this module is suitable for Notebook PC. The LED Driver for back-light driving is built in this model.

All input signals are eDP interface compatible.

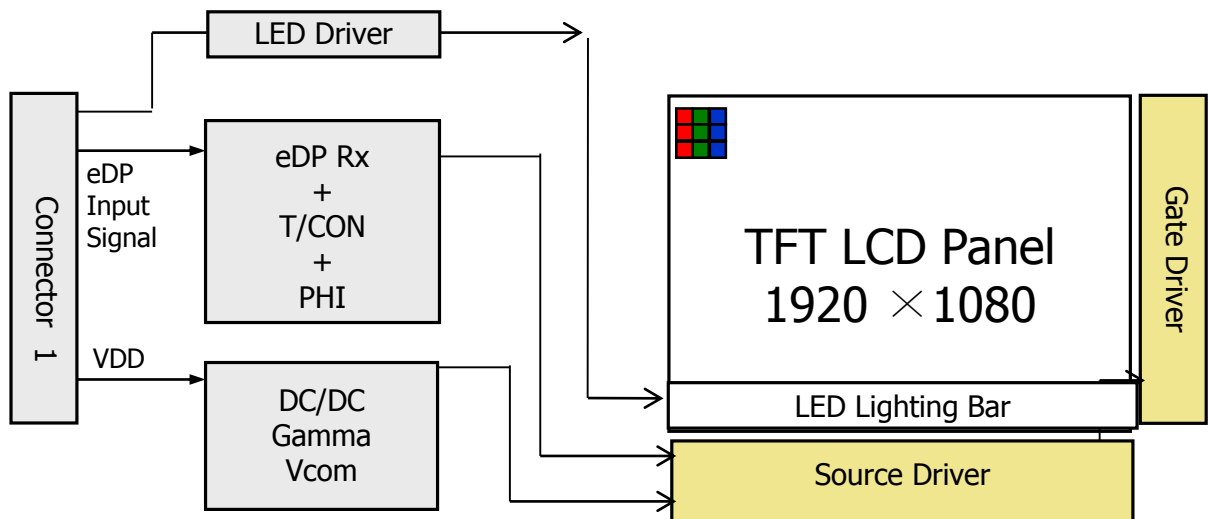

### 1.2 Features

- 2 lane eDP1.2 Interface with 2.7Gbps Link Rates
- Thin and light weight
- 6-bit color depth, display 262K colors
- Single LED Lighting Bar. (Down side/Horizontal Direction)
- Data enable signal mode
- Side Mounting Frame
- Green Product (RoHS & Halogen free product)
- On board LED Driving circuit
- Low driving voltage and low power consumption
- On board EDID chip

**1.3 Application**

- Notebook PC (Wide type)

**1.4 General Specification**

The followings are general specifications at the model NV140FHM-N41 . (listed in Table 1.)

<Table 1. General Specifications>

Parameter	Specification	Unit	Remarks
Active area	309.312(H) × 173.988(V)	mm	
Number of pixels	1920 (H) × 1080 (V)	pixels	
Pixel pitch	0.1611(H) × 0.1611 (V)	mm	
Pixel arrangement	RGB Vertical stripe		
Display colors	262K	colors	
Display mode	Normally Black		
Dimensional outline	320.4 ± 0.5 (H) × 205.1 ± 0.5 (V) × 3.0 max	mm	
Weight	290 (max)	g	
Surface treatment	Anti-Glare / 3H		
Back-light	Down edge side, 1-LED Lighting Bar type		Note 1
Power consumption	P <sub>D</sub> : 0.9 (max)	W	Note 2
	P <sub>BL</sub> : 3.2 (max)	W	
	P <sub>total</sub> : 4.1 (max)	W	

Notes : 1. LED Lighting Bar (40\*LED Array)

Notes: 2. Maximum Measurement Condition :Mosaic Pattern

## 2.0 ABSOLUTE MAXIMUM RATINGS

The followings are maximum values which, if exceed, may cause faulty operation or damage to the unit. The operational and non-operational maximum voltage and current values are listed in Table 2.

< Table 2. Absolute Maximum Ratings >

Ta=25+/-2°C

Parameter	Symbol	Min.	Max.	Unit	Remarks
Power Supply Voltage	V <sub>DD</sub>	-0.3	4.0	V	Note 1
Logic Supply Voltage	V <sub>IN</sub>	V <sub>SS</sub> -0.3	V <sub>DD</sub> +0.3	V	
Operating Temperature	T <sub>OP</sub>	0	+50	°C	Note 2
Storage Temperature	T <sub>ST</sub>	-20	+60	°C	

- Notes : 1. Permanent damage to the device may occur if maximum values are exceeded functional operation should be restricted to the condition described under normal operating conditions.
2. Temperature and relative humidity range are shown in the figure below.  
 95 % RH Max. ( 40 °C ≥ Ta)  
 Maximum wet - bulb temperature at 39 °C or less. (Ta > 40 °C) No condensation.

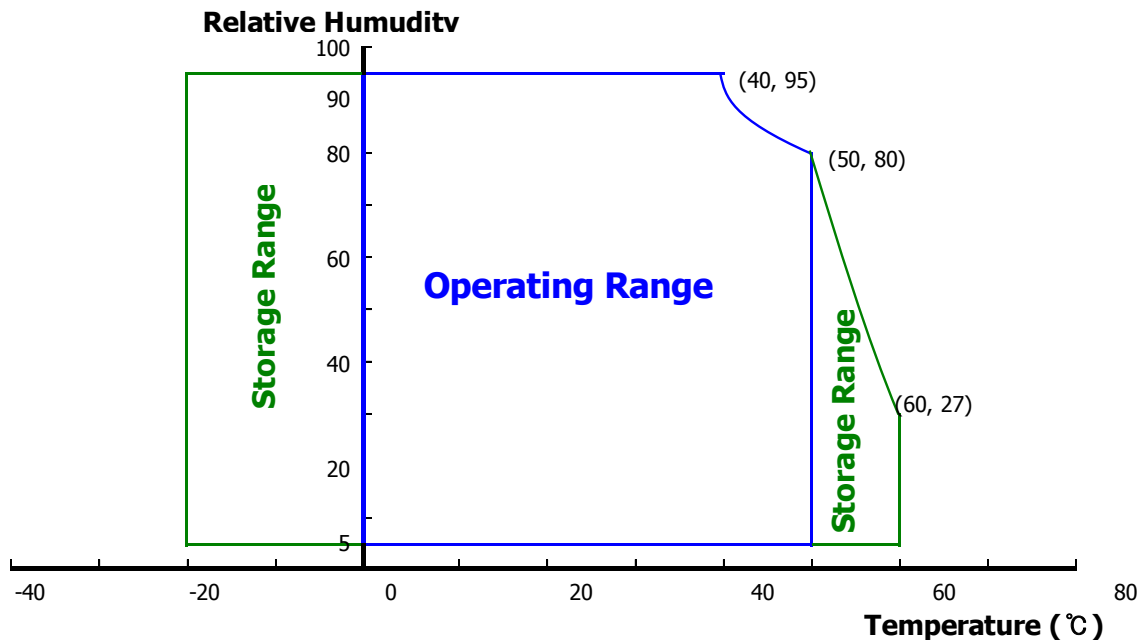

### 3.0 ELECTRICAL SPECIFICATIONS

#### 3.1 Electrical Specifications

< Table 3. Electrical specifications >

Ta=25+/-2°C

Parameter		Min.	Typ.	Max.	Unit	Remarks
Power Supply Voltage	V <sub>DD</sub>	3.0	3.3	3.6	V	Note 1
Permissible Input Ripple Voltage	V <sub>RF</sub>	-	-	100	mV	At V <sub>DD</sub> = 3.3V
Power Supply Current	I <sub>DD</sub>	-	210	-	mA	Note 1
Positive-going Input Threshold Voltage	V <sub>IT+</sub>	-	-	100	mV	V <sub>cm</sub> = 1.2V typ.
Negative-going Input Threshold Voltage	V <sub>IT-</sub>	-100	-	-	mV	
Differential Input Voltage	V <sub>ID</sub>	200	-	600	mV	
Power Consumption	P <sub>D</sub>	-	-	0.9	W	Note 1
	P <sub>BL</sub>	-	-	3.2	W	Note 2
	P <sub>total</sub>	-	-	4.1	W	

Notes : 1. The supply voltage is measured and specified at the interface connector of LCM.  
The current draw and power consumption specified is for 3.3V at 25°C.

Max : Mosaic Pattern

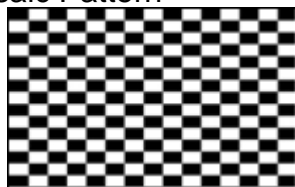

2. Calculated value for reference (V<sub>LED</sub> × I<sub>LED</sub>)

### 3.0 ELECTRICAL SPECIFICATIONS

#### 3.2 Backlight Unit

< Table 4. LED Driving guideline specifications >

Ta=25+/-2°C

Parameter		Min.	Typ.	Max.	Unit	Remarks	
LED Forward Voltage		$V_F$	-	-	3.0	V	-
LED Forward Current		$I_F$	-	23		mA	-
LED Power Consumption		$P_{LED}$		-	3.2	W	Note 1
LED Life-Time		N/A	15,000	-	-	Hour	$I_F = 23mA$
Power supply voltage for LED Driver		$V_{LED}$	6	12	21	V	
EN Control Level	Backlight on		2.2		5.0	V	
	Backlight off		0		0.6	V	
PWM Control Level	PWM High Level		2.2		5.0	V	
	PWM Low Level		0		0.6	V	
PWM Control Frequency		$F_{PWM}$	180	-	10,000	Hz	
Duty Ratio		-	1	-	100	%	

Notes : 1. Power supply voltage 12V for LED Driver, Driver efficiency 87%,

Calculator Value for reference  $I_F \times V_F \times 40 / 0.87 = P_{LED}$

2. The LED Life-time define as the estimated time to 50% degradation of initial luminous.



### 3.3 LED structure

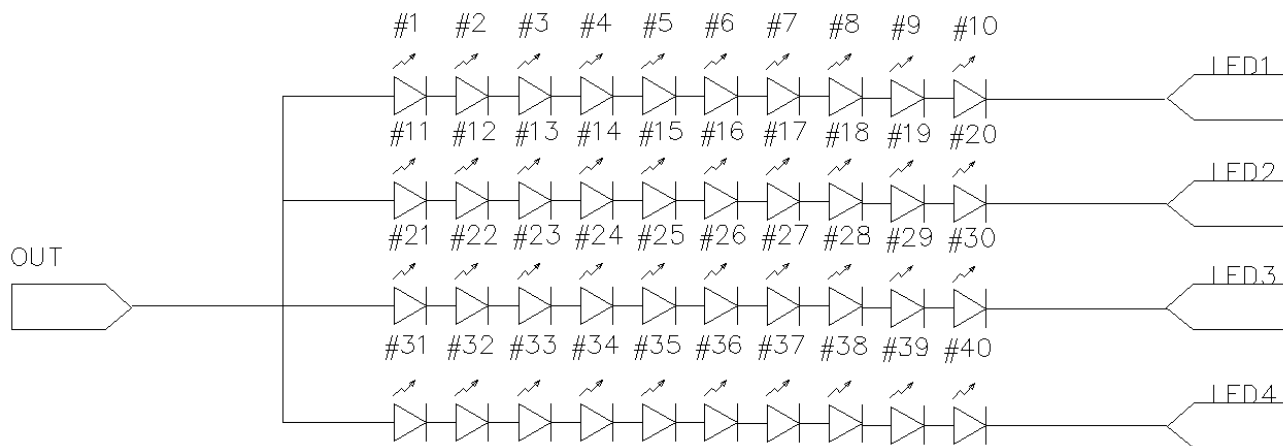

### 4.0 OPTICAL SPECIFICATION

#### 4.1 Overview

The test of Optical specifications shall be measured in a dark room (ambient luminance  $\leq 1$  lux and temperature =  $25 \pm 2^\circ\text{C}$ ) with the equipment of Luminance meter system (Goniometer system and TOPCON BM-5) and test unit shall be located at an approximate distance 50cm from the LCD surface at a viewing angle of  $\theta$  and  $\Phi$  equal to  $0^\circ$ . We refer to  $\theta\Phi=0$  ( $=\theta_3$ ) as the 3 o'clock direction (the "right"),  $\theta\Phi=90$  ( $=\theta_{12}$ ) as the 12 o'clock direction ("upward"),  $\theta\Phi=180$  ( $=\theta_9$ ) as the 9 o'clock direction ("left") and  $\theta\Phi=270$  ( $=\theta_6$ ) as the 6 o'clock direction ("bottom"). While scanning  $\theta$  and/or  $\Phi$ , the center of the measuring spot on the Display surface shall stay fixed. The backlight should be operating for 30 minutes prior to measurement. VDD shall be  $3.3 \pm 0.3\text{V}$  at  $25^\circ\text{C}$ . Optimum viewing angle direction is 6 o'clock.

#### 4.2 Optical Specifications

<Table 5. Optical Specifications>

Parameter		Symbol	Condition	Min.	Typ.	Max.	Unit	Remark
Viewing Angle range	Horizontal	$\theta_3$	CR > 10		85	-	Deg.	Note 1
		$\theta_9$			85	-	Deg.	
	Vertical	$\theta_{12}$			85	-	Deg.	
		$\theta_6$			85	-	Deg.	
Luminance Contrast ratio		CR	$\theta = 0^\circ$	600	800			Note 2
Luminance of White	5 Points	$Y_w$	$\theta = 0^\circ$ $I_{LED} = 20\text{mA}$	213	250	-	cd/m <sup>2</sup>	Note 3
White Luminance uniformity	5 Points	$\Delta Y_5$		80	-	-		Note 4
	13 Points	$\Delta Y_{13}$		65	-	-		
White Chromaticity		$x_w$	$\theta = 0^\circ$	0.283	0.313	0.343		Note 5
		$y_w$		0.299	0.329	0.359		
Reproduction of color	Red	$x_R$	$\theta = 0^\circ$	-0.03	TBD	+0.03		
		$y_R$			TBD			
	Green	$x_G$			TBD			
		$y_G$			TBD			
	Blue	$x_B$			TBD			
		$y_B$			TBD			
Response Time (Rising + Falling)		$T_{RT}$	$T_a = 25^\circ\text{C}$ $\theta = 0^\circ$	-	30	35	ms	Note 6
Cross Talk		CT	$\theta = 0^\circ$	-	-	2.0	%	Note 7

## Notes :

1. Viewing angle is the angle at which the contrast ratio is greater than 10. The viewing angles are determined for the horizontal or 3, 9 o'clock direction and the vertical or 6, 12 o'clock direction with respect to the optical axis which is normal to the LCD surface (see FIGURE 1).

2. Contrast measurements shall be made at viewing angle of  $\Theta = 0$  and at the center of the LCD surface. Luminance shall be measured with all pixels in the view field set first to white, then to the dark (black) state .

(see FIGURE 1) Luminance Contrast Ratio (CR) is defined mathematically.

$$CR = \frac{\text{Luminance when displaying a white raster}}{\text{Luminance when displaying a black raster}}$$

3. Center Luminance of white is defined as luminance values of 5 point average across the LCD surface. Luminance shall be measured with all pixels in the view field set first to white. This measurement shall be taken at the locations shown in FIGURE 2 for a total of the measurements per display.

4. The White luminance uniformity on LCD surface is then expressed as :  $\Delta Y = \text{Minimum Luminance of 5(or 13) points} / \text{Maximum Luminance of 5(or 13) points}$ .  
(see FIGURE 2 and FIGURE 3).

5. The color chromaticity coordinates specified in Table 5 shall be calculated from the spectral data measured with all pixels first in red, green, blue and white. Measurements shall be made at the center of the panel.

6. The electro-optical response time measurements shall be made as FIGURE 4 by switching the "data" input signal ON and OFF. The times needed for the luminance to change from 10% to 90% is  $T_r$ , and 90% to 10% is  $T_d$ .

7. Cross-Talk of one area of the LCD surface by another shall be measured by comparing the luminance ( $Y_A$ ) of a 25mm diameter area, with all display pixels set to a gray level, to the luminance ( $Y_B$ ) of that same area when any adjacent area is driven dark.  
(See FIGURE 5).

### 4.3 Optical measurements

**Figure 1. Measurement Set Up**

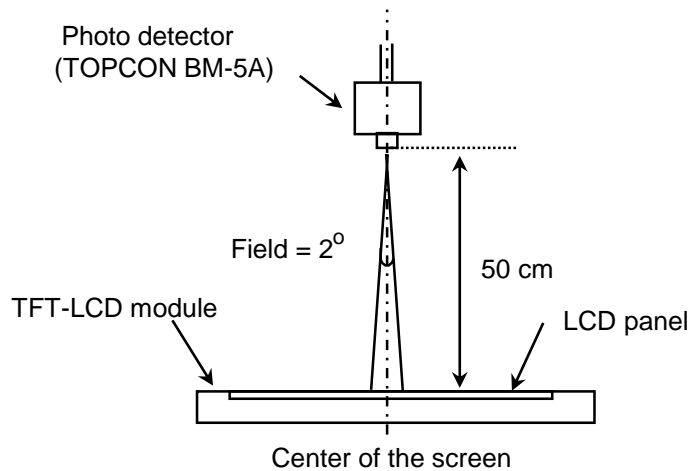

Optical characteristics measurement setup

**Figure 2. White Luminance and Uniformity Measurement Locations (5 points)**

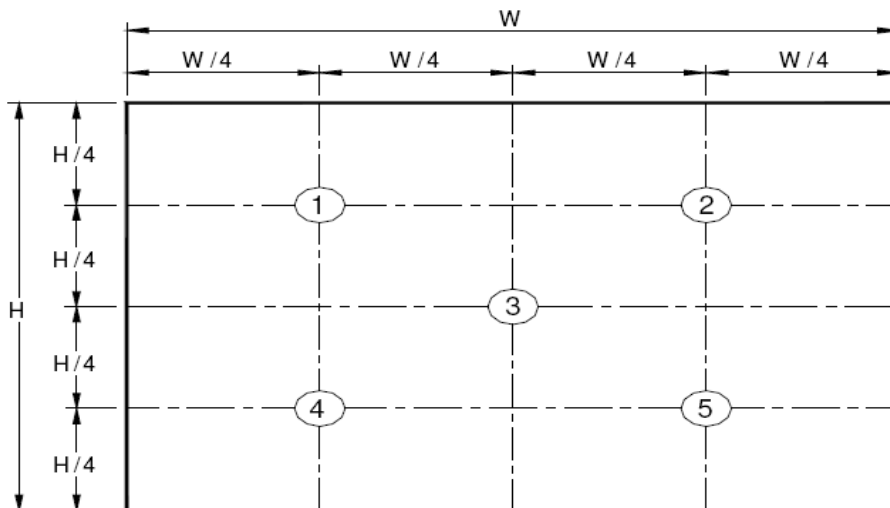

Center Luminance of white is defined as luminance values of center 5 points across the LCD surface. Luminance shall be measured with all pixels in the view field set first to white. This measurement shall be taken at the locations shown in FIGURE 2 for a total of the measurements per display.

**Figure 3. Uniformity Measurement Locations (13 points)**

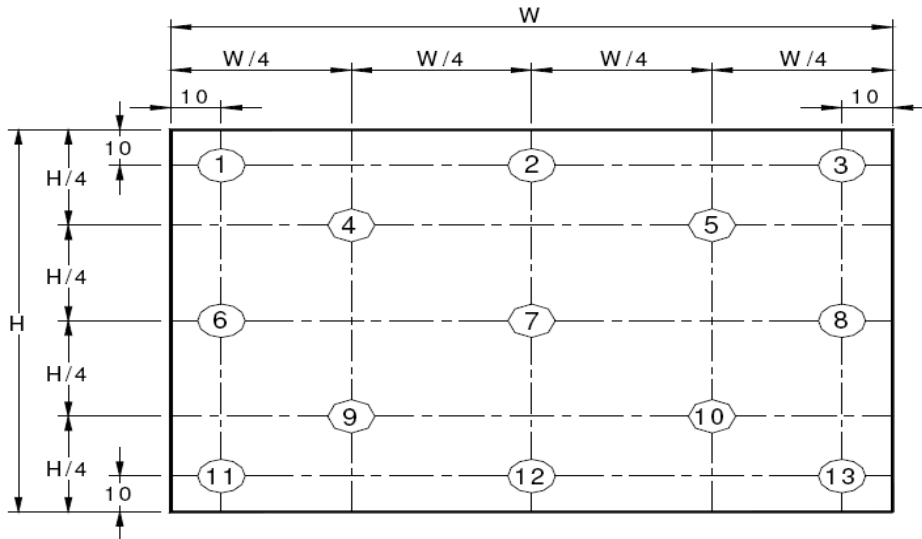

The White luminance uniformity on LCD surface is then expressed as :  $\Delta Y_5 = \text{Minimum Luminance of five points} / \text{Maximum Luminance of five points}$  (see FIGURE 2) ,  $\Delta Y_{13} = \text{Minimum Luminance of 13 points} / \text{Maximum Luminance of 13 points}$  (see FIGURE 3).

**Figure 4. Response Time Testing**

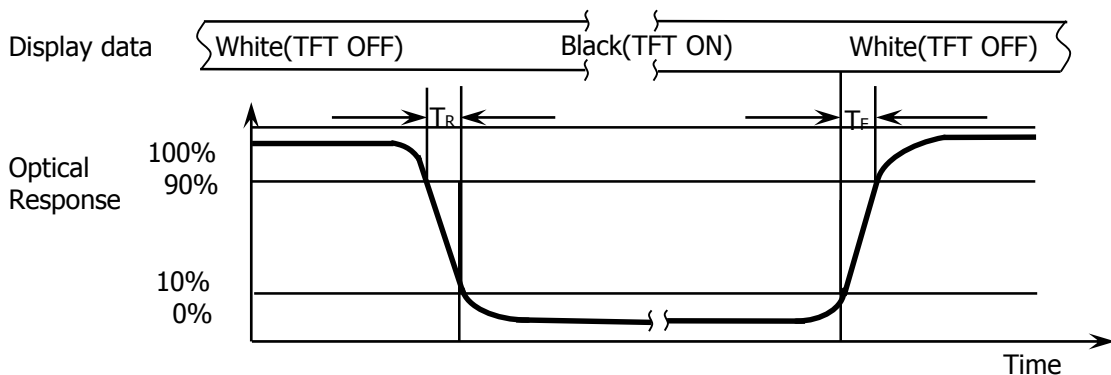

The electro-optical response time measurements shall be made as shown in FIGURE 4 by switching the “data” input signal ON and OFF. The times needed for the luminance to change from 10% to 90% is  $T_d$  and 90% to 10% is  $T_r$ .

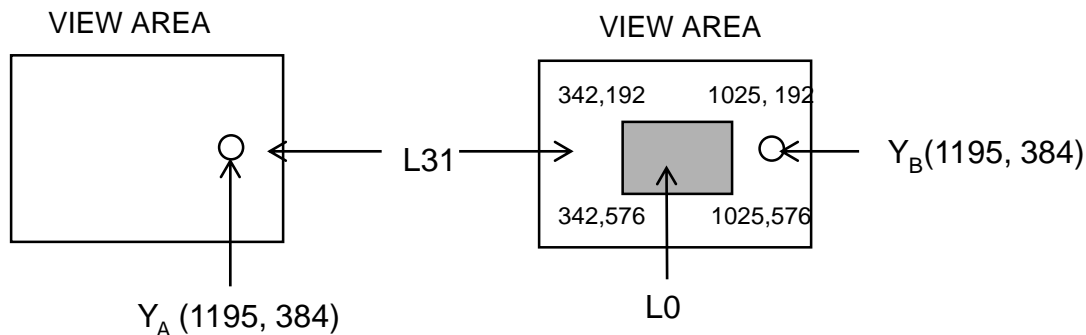
**Figure 5. Cross Modulation Test Description**

$$\text{Cross-Talk (\%)} = \left| \frac{Y_B - Y_A}{Y_A} \right| \times 100$$

Where:

$Y_A$  = Initial luminance of measured area ( $\text{cd/m}^2$ )

$Y_B$  = Subsequent luminance of measured area ( $\text{cd/m}^2$ )

The location measured will be exactly the same in both patterns

Cross-Talk of one area of the LCD surface by another shall be measured by comparing the luminance ( $Y_A$ ) of a 25mm diameter area, with all display pixels set to a gray level, to the luminance ( $Y_B$ ) of that same area when any adjacent area is driven dark (Refer to FIGURE 5).

## 5.0 INTERFACE CONNECTION.

### 5.1 Electrical Interface Connection

The electronics interface connector is UJU IS050-L30B-C10

The connector interface pin assignments are listed in Table 6.

<Table 6. Pin Assignments for the Interface Connector>

Terminal	Symbol	Functions
Pin No.	Symbol	Description
1	CABC_ENIN	CABC Control Enable
2	H_GND	Ground
3	LANE1_N	eDP RX channel 1 negative
4	LANE1_P	eDP RX channel 1 positive
5	H_GND	Ground
6	LANE0_N	eDP RX channel 0 negative
7	LANE0_P	eDP RX channel 0 positive
8	H_GND	Ground
9	AUX_CH_P	eDP AUX CH positive
10	AUX_CH_N	eDP AUX CH negative
11	H_GND	Ground
12	LCD_VCC	Power Supply, 3.3V (typ.)
13	LCD_VCC	Power Supply, 3.3V (typ.)
14	NC	No Connection
15	H_GND	Ground
16	H_GND	Ground
17	HPD	Hot plug detect output
18	BL_GND	LED Ground
19	BL_GND	LED Ground
20	BL_GND	LED Ground
21	BL_GND	LED Ground
22	BL_ENABLE	LED enable pin(+3.3V Input)
23	BL_PWM	System PWM Signal Input
24	H-Sync	H-Sync
25	NC	No Connection
26	BL_POWER	LED Power Supply 5V-21V
27	BL_POWER	LED Power Supply 5V-21V
28	BL_POWER	LED Power Supply 5V-21V
29	BL_POWER	LED Power Supply 5V-21V
30	NC	Panel self test enable

### 5.2. eDP Interface

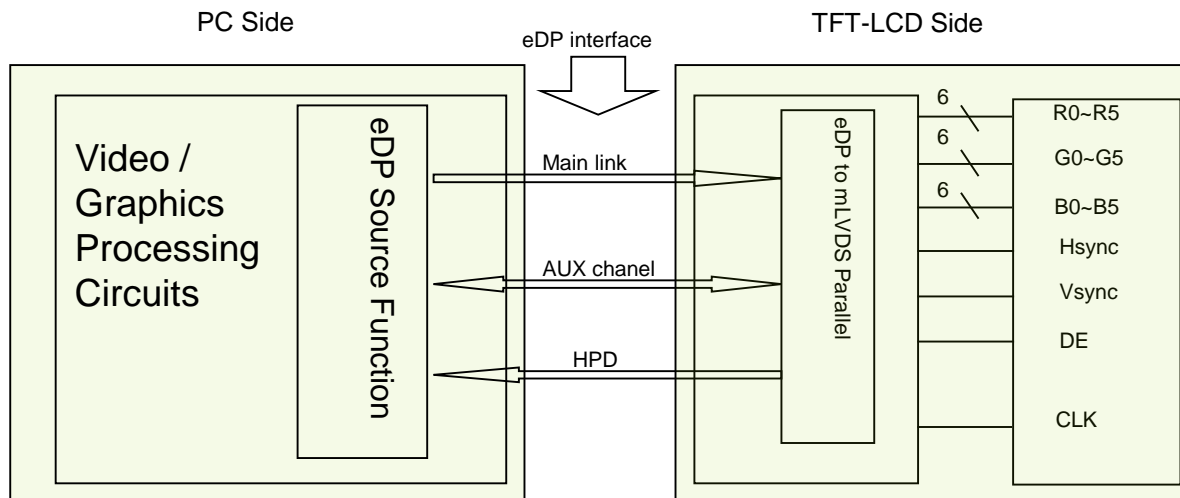

Note. Transmitter : Parade DP501 or equivalent.  
Transmitter is not contained in Module.

### 5.3. eDP Input signal

Lane0	
R0-5:0	G0-5:4
G0-3:0	B0-5:2
B0-1:0	R1-5:0
G1-5:0	B1-5:4
B1-3:0	R2-5:2
R2-1:0	G2-5:0
B2-5:0	R3-5:4
R3-3:0	G3-5:2
G3-1:0	B3-5:0



## 5.4 Data Input Format

<Table 6. Pin Assignments for the Interface Connector>

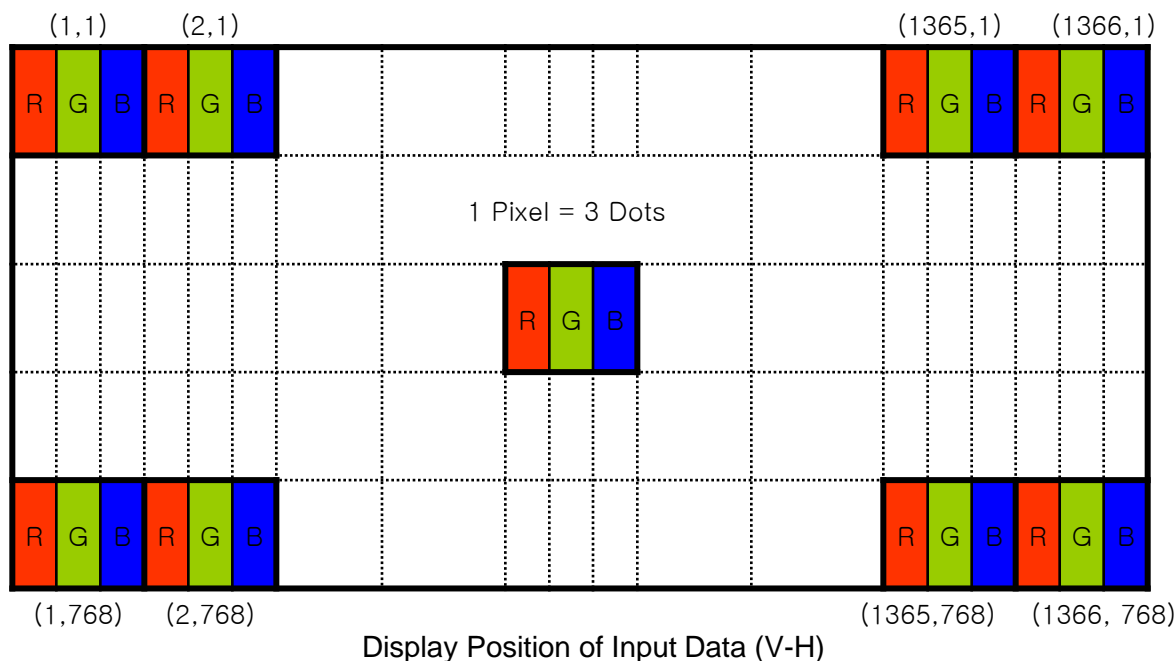

## 5.5 Back-light & LCM Interface Connection

Interface Connector: MSK24022P10

<Table 7. Pin Assignments for the BLU & LCM Connector>

Pin No.	Symbol	Description	Pin No.	Symbol	Description
1	LED1	LED cathode connection	6	LED6	LED cathode connection
2	LED2	LED cathode connection	7	GND	Ground
3	LED3	LED cathode connection	8	NC	No Connection
4	LED4	LED cathode connection	9	Vout	LED anode connection
5	LED5	LED cathode connection	10	Vout	LED anode connection

**6.0 SIGNAL TIMING SPECIFICATION****6.1 The NV140FHM-N41 is operated by the DE only.**

Item		Symbols	Min	Typ	Max	Unit
Clock	Frequency	$1/T_c$	100	148.5	160	MHz
	High Time	$T_{ch}$	-	$4/7T_c$	-	Tc
	Low Time	$T_{cl}$	-	$4/7T_c$	-	Tc
Frame Period		$T_v$	1112	1125	1238	lines
			40	60	66	Hz
			25	16.67	15.15	ms
Vertical Display Period		$T_{vd}$	-	1080	-	lines
One line Scanning Period		$T_h$	2080	2200	2400	clocks
Horizontal Display Period		$T_{hd}$	-	1920	-	clocks

Note : This module can support low frame refresh rate 50Hz&40Hz.

### 6.2 eDP Rx Interface Timing Parameter

The specification of the eDP Rx interface timing parameter is shown in Table 8.

<Table 8. eDP Rx Interface Timing Specification>

Item	Symbol	Min	Typ	Max	Unit	Remark
Spread spectrum clock	SSC		0.5		%	
Differential peak-to-peak input voltage at package pins	VRX-DIFFp-p	100	0	1320	mV	
Rx input DC common mode voltage	VRX_DC_CM	-	GND	-	V	
Differential termination resistance	RRX-DIFF	80	-	100	$\Omega$	
Single-ended termination resistance	RRX-SE	40	-	60	$\Omega$	
Rx short circuit current limit	IRX_SHORT	-	-	20	mA	
Intra-pair skew at Rx package pins (HBR) RX intra-pair skew tolerance at HBR	LRX_SKEW_INTRA_PAIR	-	-	150	ps	

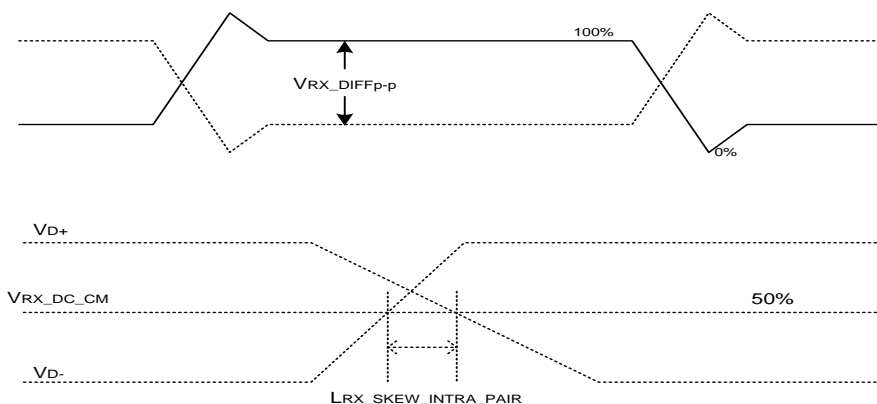

### 7.0 INPUT SIGNALS, BASIC DISPLAY COLORS & GRAY SCALE OF COLORS

	Colors & Gray scale	Data signal																	
		R0	R1	R2	R3	R4	R5	G0	G1	G2	G3	G4	G5	B0	B1	B2	B3	B4	B5
Basic colors	Black	0	0	0	0	0	0	0	0	0	0	0	0	0	0	0	0	0	0
	Blue	0	0	0	0	0	0	0	0	0	0	0	0	1	1	1	1	1	1
	Green	0	0	0	0	0	0	1	1	1	1	1	1	0	0	0	0	0	0
	Light Blue	0	0	0	0	0	0	1	1	1	1	1	1	1	1	1	1	1	1
	Red	1	1	1	1	1	1	0	0	0	0	0	0	0	0	0	0	0	0
	Purple	1	1	1	1	1	1	0	0	0	0	0	0	1	1	1	1	1	1
	Yellow	1	1	1	1	1	1	1	1	1	1	1	1	0	0	0	0	0	0
	White	1	1	1	1	1	1	1	1	1	1	1	1	1	1	1	1	1	1
Gray scale of Red	Black	0	0	0	0	0	0	0	0	0	0	0	0	0	0	0	0	0	0
	△	1	0	0	0	0	0	0	0	0	0	0	0	0	0	0	0	0	0
	Darker	0	1	0	0	0	0	0	0	0	0	0	0	0	0	0	0	0	0
	△	↑						↑						↑					
	▽	↓						↓						↓					
	Brighter	1	0	1	1	1	1	0	0	0	0	0	0	0	0	0	0	0	0
	▽	0	1	1	1	1	1	0	0	0	0	0	0	0	0	0	0	0	0
	Red	1	1	1	1	1	1	0	0	0	0	0	0	0	0	0	0	0	0
Gray scale of Green	Black	0	0	0	0	0	0	0	0	0	0	0	0	0	0	0	0	0	0
	△	0	0	0	0	0	0	1	0	0	0	0	0	0	0	0	0	0	0
	Darker	0	0	0	0	0	0	0	1	0	0	0	0	0	0	0	0	0	0
	△	↑						↑						↑					
	▽	↓						↓						↓					
	Brighter	0	0	0	0	0	0	1	0	1	1	1	1	0	0	0	0	0	0
	▽	0	0	0	0	0	0	0	1	1	1	1	1	0	0	0	0	0	0
	Green	0	0	0	0	0	0	1	1	1	1	1	1	0	0	0	0	0	0
Gray scale of Blue	Black	0	0	0	0	0	0	0	0	0	0	0	0	0	0	0	0	0	0
	△	0	0	0	0	0	0	0	0	0	0	0	0	1	0	0	0	0	0
	Darker	0	0	0	0	0	0	0	0	0	0	0	0	0	1	0	0	0	0
	△	↑						↓						↑					
	▽	↓						↓						↓					
	Brighter	0	0	0	0	0	0	0	0	0	0	0	0	1	0	1	1	1	1
	▽	0	0	0	0	0	0	0	0	0	0	0	0	0	1	1	1	1	1
	Blue	0	0	0	0	0	0	0	0	0	0	0	0	1	1	1	1	1	1
Gray scale of White & Black	Black	0	0	0	0	0	0	0	0	0	0	0	0	0	0	0	0	0	0
	△	1	0	0	0	0	0	1	0	0	0	0	0	1	0	0	0	0	0
	Darker	0	1	0	0	0	0	0	1	0	0	0	0	0	1	0	0	0	0
	△	↑						↑						↑					
	▽	↓						↓						↓					
	Brighter	1	0	1	1	1	1	1	0	1	1	1	1	1	0	1	1	1	1
	▽	0	1	1	1	1	1	0	1	1	1	1	1	0	1	1	1	1	1
	White	1	1	1	1	1	1	1	1	1	1	1	1	1	1	1	1	1	1

## 8.0 POWER SEQUENCE

To prevent a latch-up or DC operation of the LCD module, the power on/off sequence shall be as shown in below

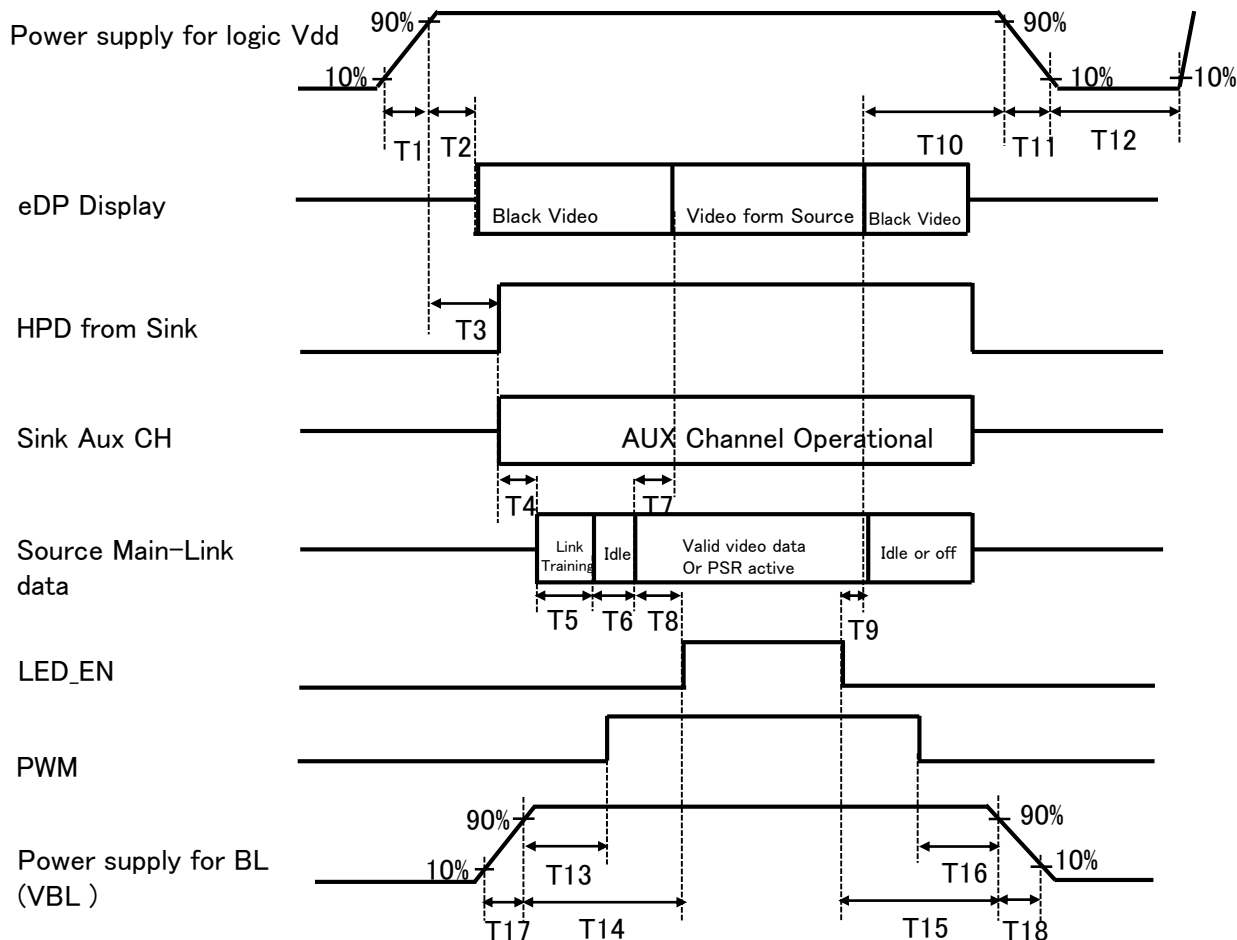

- $0.5\text{ms} \leq T1 \leq 10\text{ms}$
- $0\text{ms} \leq T2 \leq 200\text{ms}$
- $0\text{ms} \leq T3 \leq 200\text{ms}$
- $10\text{ms} \leq T13$
- $20\text{ms} \leq T14$
- $0.5\text{ms} \leq T17 \leq 20\text{ms}$

- $0\text{ms} \leq T7 \leq 50\text{ms}$
- $0\text{ms} \leq T10 \leq 500\text{ms}$
- $T11 \leq 10\text{ms}$
- $500\text{ms} \leq T12$
- $20\text{ms} \leq T15$
- $10\text{ms} \leq T16$
- $0.5\text{ms} \leq T18 \leq 20\text{ms}$

### Notes:

1. When the power supply VDD is 0V, keep the level of input signals on the low or keep high impedance.
2. Do not keep the interface signal high impedance when signal invalid period.
3. Backlight power must be turn on after power for logic and interface signal is valid.

## 9.0 Connector Description

Physical interface is described as for the connector on LCM.

These connectors are capable of accommodating the following signals and will be following components.

### 9.1 TFT LCD Module

<b>Connector Name /Description</b>	<b>For Signal Connector</b>
Manufacturer	UJU
Type/ Part Number	IS050-L30B-C10
Mating housing/ Part Number	I-PEX 20454-030T or Compatible

## 10.0 MECHANICAL CHARACTERISTICS

### 10.1 Dimensional Requirements

FIGURE 6 shows mechanical outlines for the model NV140FHM-N41.  
Other parameters are shown in Table 9.

<Table 9. Dimensional Parameters>

Parameter	Specification	Unit
Active Area	309.312 (H) × 173.988 (V)	
Number of pixels	1920 (H) X 1080 (V) (1 pixel = R + G + B dots)	
Pixel pitch	0.1611 (H) X 0.1611 (V)	
Pixel arrangement	RGB Vertical stripe	
Display colors	262K	
Display mode	Normally Black	
Dimensional outline	320.4 ± 0.5*198.6 ± 0.5*3.0max	mm
Weight	290 (max)	gram
Back Light	Connector : MSK24022P10	
	LED, Horizontal-LED Array type	

### 10.2 Mounting

See FIGURE 6.

### 10.3 Anti-Glare and Polarizer Hardness.

The surface of the LCD has an AG coating to minimize reflection and a coating to reduce scratching.

### 10.4 Light Leakage

There shall not be visible light from the back-lighting system around the edges of the screen as seen from a distance 50cm from the screen with an overhead light level of 350lux.

## 11.0 RELIABILITY TEST

The Reliability test items and its conditions are shown in below.

<Table 10. Reliability test>

No	Test Items	Conditions
1	High temperature storage test	Ta = 60 °C, 240 hrs
2	Low temperature storage test	Ta = -20 °C, 240 hrs
3	High temperature & high humidity operation test	Ta = 50 °C, 80%RH, 240 hrs
4	High temperature operation test	Ta = 50 °C, 240 hrs
5	Low temperature operation test	Ta = 0 °C, 240 hrs
6	Thermal shock	Ta = -20 °C ↔ 60 °C (0.5 hr), 100 cycle
7	Vibration test (non-operating)	1.5G, 10~500Hz, Half Sine X,Y,Z / Sweep rate : 1 hour
8	Shock test (non-operating)	220G, Half Sine Wave 2msec ± X, ± Y, ± Z Once for each direction
9	Electro-static discharge test (non-operating)	Air : 150 pF, 330Ω, 15 KV Contact : 150 pF, 330Ω, 8 KV

## 12.0 HANDLING & CAUTIONS

### (1) Cautions when taking out the module

- Pick the pouch only, when taking out module from a shipping package.

### (2) Cautions for handling the module

- As the electrostatic discharges may break the LCD module, handle the LCD module with care. Peel a protection sheet off from the LCD panel surface as slowly as possible.
- As the LCD panel and back - light element are made from fragile glass material, impulse and pressure to the LCD module should be avoided.
- As the surface of the polarizer is very soft and easily scratched, use a soft dry cloth without chemicals for cleaning.
- Do not pull the interface connector in or out while the LCD module is operating.
- Put the module display side down on a flat horizontal plane.
- Handle connectors and cables with care.

### (3) Cautions for the operation

- When the module is operating, do not lose CLK, ENAB signals. If any one of these signals is lost, the LCD panel would be damaged.
- Obey the supply voltage sequence. If wrong sequence is applied, the module would be damaged.



<b>BOE</b>	<b>PRODUCT GROUP</b>	REV	ISSUE DATE
	TFT- LCD PRODUCT	P0	2014.11.13
SPEC. NUMBER	SPEC. TITLE NV140FHM-N41 Preliminary Product Specification		PAGE 25 OF 32

- (4) Cautions for the atmosphere
- Dew drop atmosphere should be avoided.
  - Do not store and/or operate the LCD module in a high temperature and/or humidity atmosphere. Storage in an electro-conductive polymer packing pouch and under relatively low temperature atmosphere is recommended.
- (5) Cautions for the module characteristics
- Do not apply fixed pattern data signal to the LCD module at product aging.
  - Applying fixed pattern for a long time may cause image sticking.
- (6) Other cautions
- Do not disassemble and/or re-assemble LCD module.
  - Do not re-adjust variable resistor or switch etc.
  - When returning the module for repair or etc., Please pack the module not to be broken. We recommend to use the original shipping packages.

### 13.0 LABEL

#### (1) Product label

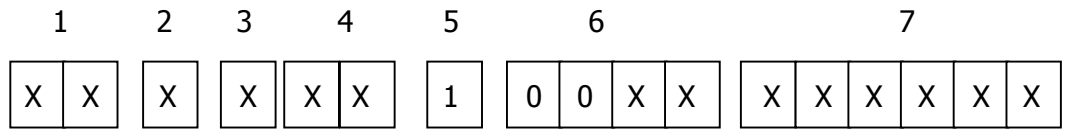

Type designation

No 1. Control Number

No 2. Rank / Grade

No 3. Line classification

No 4. Year (10 : 2010, 11: 2011, ...)

No 5. Month (1, 2, 3, ..., 9, X, Y, Z)

No 6. Product Identification (FG)

No 7. Serial Number

### (2) High voltage caution label

	<p>HIGH VOLTAGE CAUTION</p>	<p>COLD CATHODE FLUORESCENT LAMP IN LCD PANEL CONTAINS A SMALL AMOUNT OF MERCURY. PLEASE FOLLOW LOCAL ORDINANCES OR REGULATIONS FOR DISPOSAL.</p>
	<p>RISK OF ELECTRIC SHOCK. DISCONNECT THE ELECTRIC POWER BEFORE SERVICING</p>	

### (3) Box label

Label Size: 110 mm (L) × 56 mm (W)

Contents

Model: NV140FHM-N41

Q`ty: Module Q`ty in one box

Serial No.: Box Serial No. See next figure for detail description.

Date: Packing Date

Internal use of Product

		<h2>BOE BEIJING BOE DISPLAY TECHNOLOGY</h2>	
MODEL:	<b>NV140FHM-N41</b>	Q`TY:	<b>38</b>
SERIAL NO:	<b>XXXXXXXXXXXXXX</b>	DATE:	<b>201X/XX/XX</b>
			
<p><b>XXXX</b></p>			

SERIA NO	1	2	3	4	5	6	7	8	9	10	11	12	13
code	X	X	X	X	X	X	X	X	X	X	X	X	X
Description	GBN		Grade	Line	Year	Month	Rev	Serial No.					

## 14.0 PACKING INFORMATION

### 14.1 Packing order

- Put Pad into the inner box
- Insert EPE block into the Gap between Pad and box

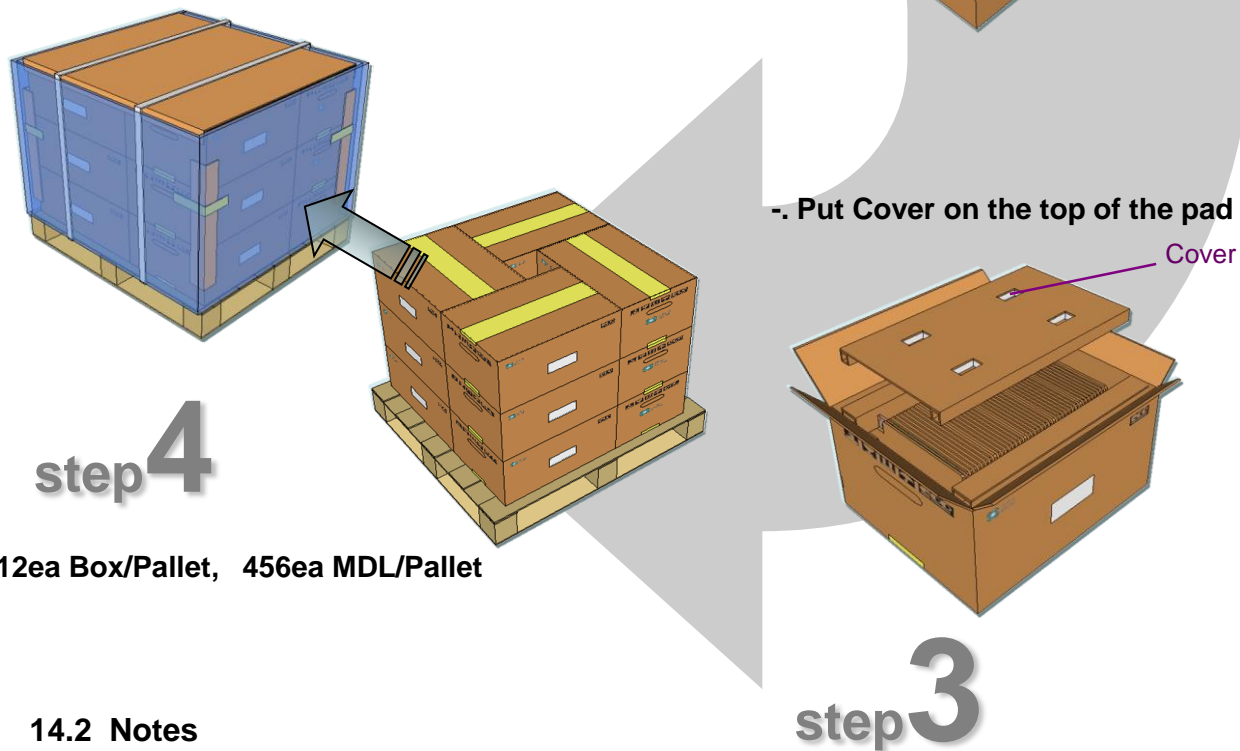
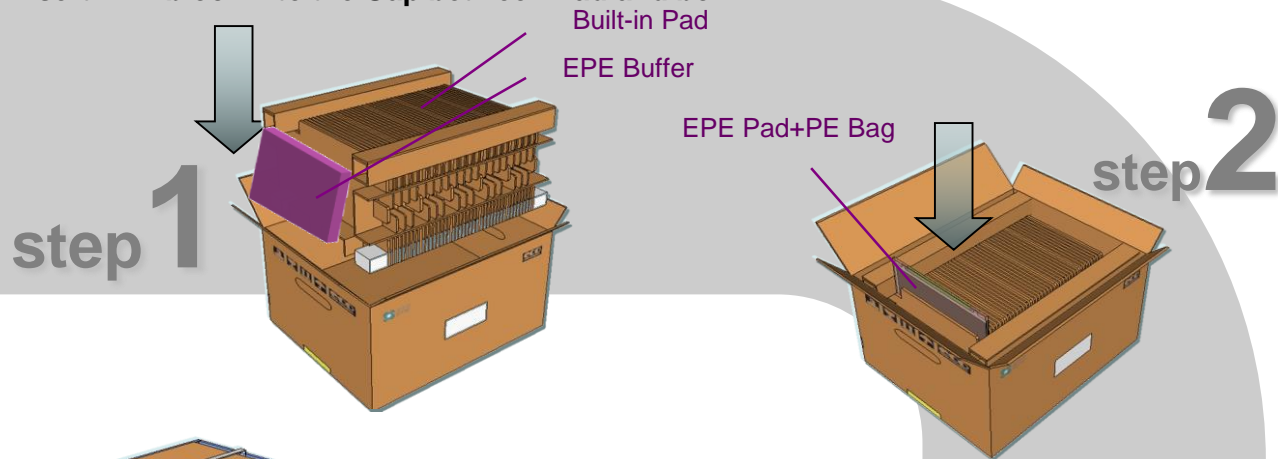

- 12ea Box/Pallet, 456ea MDL/Pallet

### 14.2 Notes

- Box Dimension: 580mm(W) x 450mm(D) x 280mm(H)
- Package Quantity in one Box: 38pcs
- Total Weight: 15kg

## 15.0 MECHANICAL OUTLINE DIMENSION

Figure 6. TFT-LCD Module Outline Dimension (Front View)

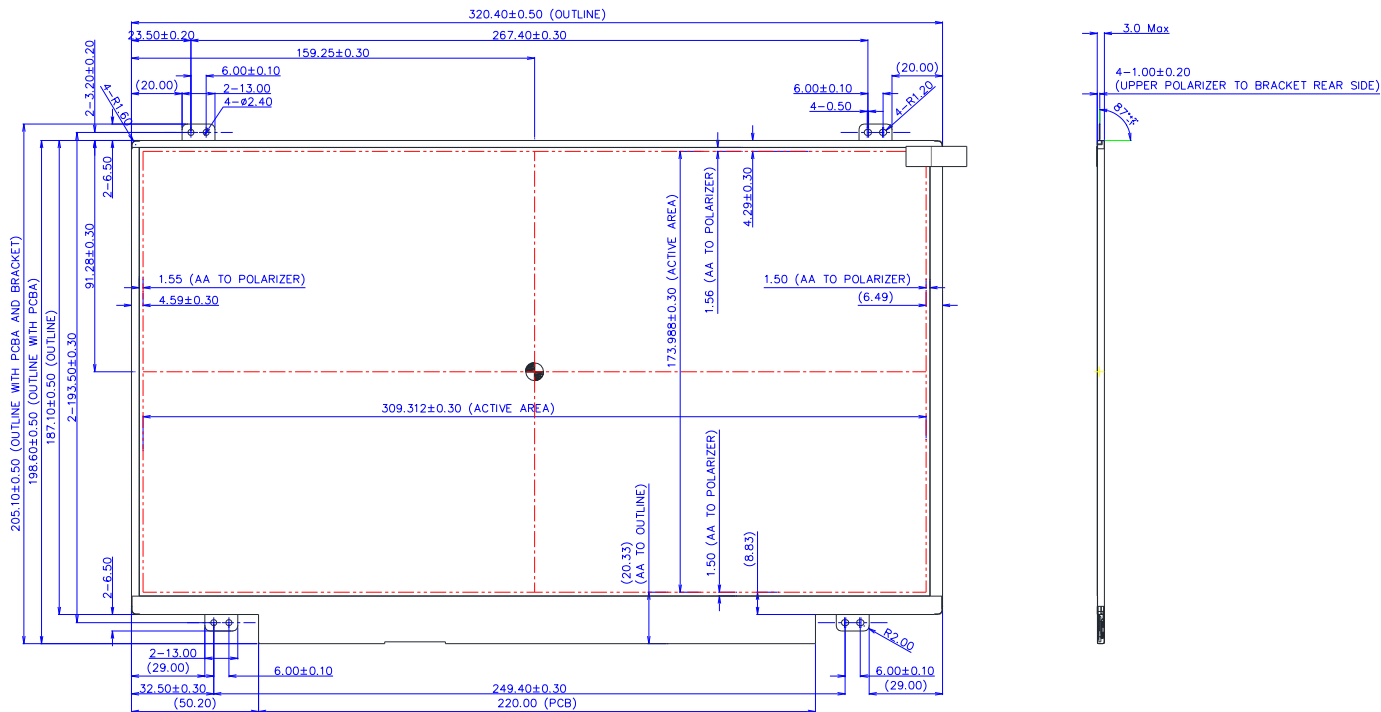

### Figure 7. TFT-LCD Module Outline Dimensions (Rear view)

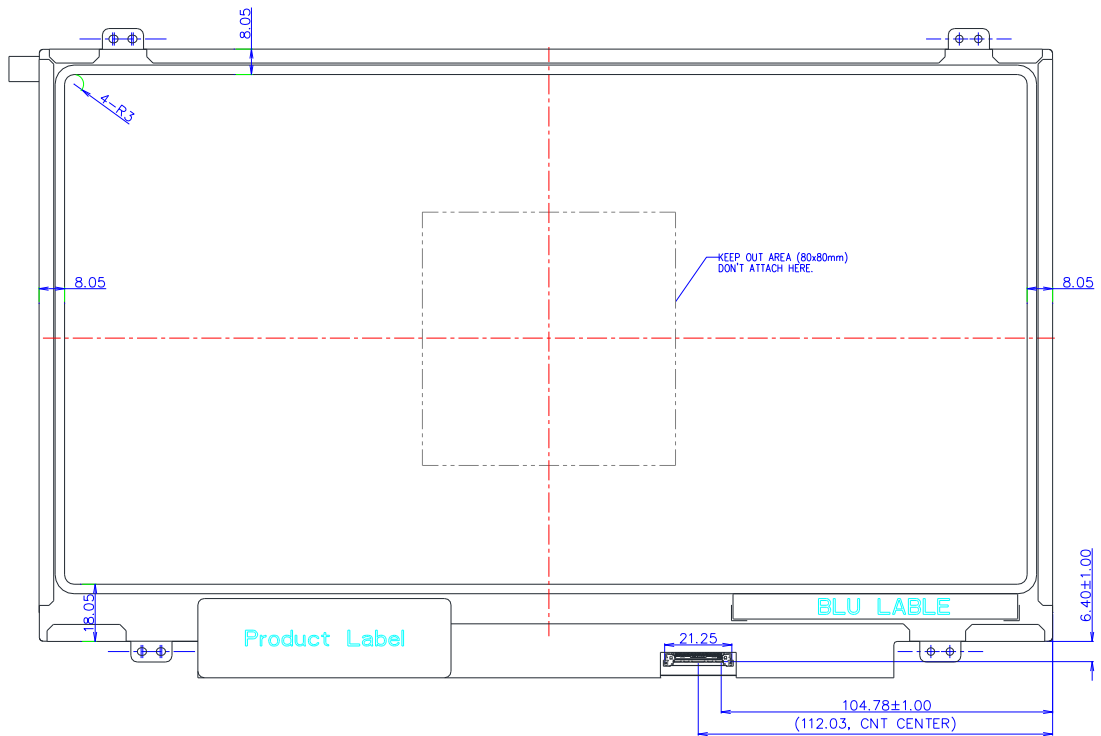

### 16.0 EDID Table

Address (HEX)	Function	Hex	Dec	crc	Input values.	Notes
00	Header	00	0		0	EDID Header
01		FF	255		255	
02		FF	255		255	
03		FF	255		255	
04		FF	255		255	
05		FF	255		255	
06		FF	255		255	
07		00	0		0	
08	ID Manufacturer Name	09	9		BOE	ID = BOE
09		E5	229			
0A	ID Product Code	F3	243		1523	ID = 1523
0B		05	5			
0C	32-bit serial No.	00	0			
0D		00	0			
0E		00	0			
0F		00	0			
10	Week of manufacture	01	1		1	
11	<b>Year of Manufacture</b>	17	23		2013	Manufactured in 2013
12	EDID Structure Ver.	01	1		1	EDID Ver 1.0
13	EDID revision #	04	4		4	EDID Rev. 0.4
14	Video input definition	95	149		-	digital signal/DP input
15	Max H image size	1F	31		31	31 cm (Approx)
16	Max V image size	11	17		17	17 cm (Approx)
17	Display Gamma	78	120		2.2	Gamma curve = 2.2
18	Feature support	02	2			RGB display, Preferred Timming mode/RGB 4:4:4
19	Red/Green low bits	58	88		-	Red / Green Low Bits
1A	Blue/White low bits	20	32		-	Blue / White Low Bits
1B	Red x high bits	92	146	585	0.572	Red (x) = 10010010 (0.572)
1C	Red y high bits	5B	91	365	0.357	Red (y) = 01011011 (0.357)
1D	Green x high bits	57	87	350	0.342	Green (x) = 01010111 (0.342)
1E	Green y high bits	96	150	600	0.586	Green (y) = 10010110 (0.586)
1F	Blue x high bits	29	41	164	0.161	Blue (x) = 00101001 (0.161)
20	Blue y high bits	19	25	102	0.1	Blue (y) = 00011001 (0.1)
21	White x high bits	50	80	320	0.313	White (x) = 01010000 (0.313)
22	White y high bits	54	84	336	0.329	White (y) = 01010100 (0.329)



PRODUCT GROUP

REV

ISSUE DATE

TFT- LCD PRODUCT

P0

2014.11.13

SPEC. NUMBER

SPEC. TITLE

NV140FHM-N41 Preliminary Product Specification

PAGE

31 OF 32

Address (HEX)	Function	Hex	Dec	crc	Input values.	Notes
23	Established timing 1	00	0		-	
24	Established timing 2	00	0		-	
25	Established timing 3	00	0		-	
26	Standard timing #1	01	1			Not Used
27		01	1			
28	Standard timing #2	01	1			Not Used
29		01	1			
2A	Standard timing #3	01	1			Not Used
2B		01	1			
2C	Standard timing #4	01	1			Not Used
2D		01	1			
2E	Standard timing #5	01	1			Not Used
2F		01	1			
30	Standard timing #6	01	1			Not Used
31		01	1			
32	Standard timing #7	01	1			Not Used
33		01	1			
34	Standard timing #8	01	1			Not Used
35		01	1			
36	Detailed timing/monit or descriptor #1	64	100		70.1	70.12MHz Main clock
37		1B	27			
38		56	86		1366	Hor Active = 1366
39		77	119		119	Hor Blanking = 119
3A		50	80		-	4 bits of Hor. Active + 4 bits of Hor. Blanking
3B		00	0		768	Ver Active = 768
3C		13	19		19	Ver Blanking = 19
3D		30	48		-	4 bits of Ver. Active + 4 bits of Ver. Blanking
3E		30	48		48	Hor Sync Offset = 48
3F		20	32		32	H Sync Pulse Width = 32
40		36	54		3	V sync Offset = 3 line
41		00	0		6	V Sync Pulse width : 6 line
42		35	53		309	Horizontal Image Size = 309 mm (Low 8 bits)
43		AD	173		173	Vertical Image Size = 173 mm (Low 8 bits)
44		10	16		-	4 bits of Hor Image Size + 4 bits of Ver Image Size
45		00	0		0	Hor Border (pixels)
46	00	0		0	Vertical Border (Lines)	
47	1A	26			Refer to right table	



PRODUCT GROUP

REV

ISSUE DATE

TFT- LCD PRODUCT

P0

2014.11.13

SPEC. NUMBER

SPEC. TITLE

NV140FHM-N41 Preliminary Product Specification

PAGE

32 OF 32

Address (HEX)	Function	Hex	Dec	crc	Input values.	Notes
48	Detailed timing/monit or descriptor #2	70	112		<b>60.0</b>	<b>60MHz Main clock</b>
49		17	23			
4A		56	86		1366	Hor Active = 1366
4B		8C	140		140	Hor Blanking = 140
4C		50	80		-	4 bits of Hor. Active + 4 bits of Hor. Blanking
4D		00	0		768	Ver Active = 768
4E		3E	62		62	Ver Blanking = 62
4F		30	48		-	4 bits of Ver. Active + 4 bits of Ver. Blanking
50		30	48		48	Hor Sync Offset = 48
51		20	32		32	H Sync Pulse Width = 32
52		36	54		3	V sync Offset = 3 line
53		00	0		6	V Sync Pulse width : 6 line
54		35	53		309	Horizontal Image Size = 309 mm (Low 8 bits)
55		AD	173		173	Vertical Image Size = 173 mm (Low 8 bits)
56		10	16		-	4 bits of Hor Image Size + 4 bits of Ver Image Size
57		00	0		0	Hor Border (pixels)
58	00	0		0	Vertical Border (Lines)	
59	1A	26				
5A	Detailed timing/monit or descriptor #3	00	0			ASCII Data Sting Tag
5B		00	0			
5C		00	0			
5D		FE	254			
5E		00	0		W	D/PN:W92HV
5F		39	57		9	
60		32	50		2	
61		48	72		H	
62		56	86		V	EDID:A00
63		80	128		10000000	
64		48	72		H	
65		42	66		B	
66		31	49		1	
67		34	52		4	
68	36	54		6		
69	30	48		0		
6A	31	49		1	BOE PN	
6B	70	112		60.0		
						60MHz Main clock





# PRODUCT GROUP

REV

ISSUE DATE

TFT- LCD PRODUCT

P0

2014.11.13

SPEC. NUMBER

SPEC. TITLE

NV140FHM-N41 Preliminary Product Specification

PAGE

33 OF 32

Address (HEX)	Function	Hex	Dec	crc	Input values.	Notes
6C	Detailed timing/monit or descriptor #4	00	0			Product Name Tag (ASCII)
6D		00	0			
6E		00	0			
6F		00	0			
70		00	0			
71		00	0		00000000	6-bit Color Depth & no FRC
72		41	65		01000001	WLED & singal light bar & one light bar
73		01	1		00000001	Frame rate 40Hz~65Hz
74		94	148		10010100	Light Controller:PWM & Max. Luminance 200
75		00	0		00000000	Front Surface:Anti-Glare
76		10	16		00010000	with DBC
77		00	0		00000000	no Motion Blur & no Active Gamma
78		00	0		00000000	no Wireless Enhancement & no In-Cell Scanner
79		09	9		00001001	1 Lane edp1.2
7A		01	1		00000001	Built-In Self Test
7B		0A	10			
7C	20	32				
7D	20	32				
7E	Extension flag	00	0			
7F	Checksum	B4	180	180	-	